

## INSTALLATION INSTRUCTIONS FOR DROPSPOT™ ON-WALL BOTTLE FILLERS

### DRS-100 Bottle Filler



### SLOAN® LIMITED WARRANTY SUMMARY

Sloan Valve Company ("Sloan"), warrants its products against defects in materials and workmanship, excluding damage caused by matters beyond Sloan's reasonable control. Instructions for filing claims can be found in the Limited Warranty which can be obtained at [www.sloan.com](http://www.sloan.com) or by requesting a free copy by telephone at 888.756.2614. Sloan will repair or replace your defective product, or provide a refund, as your exclusive remedy. This is only a general summary of Sloan's Limited Warranty so it is important to note that the specific terms, conditions, limitations and exclusions, including the duration of warranty coverage for your particular Sloan product, are contained in the actual Sloan Limited Warranty. The Limited Warranty is subject to applicable laws in your country, state, province or other jurisdiction—and disputes arising under the Limited Warranty are to be resolved by binding arbitration unless you provide Sloan with an opt-out notice no later than 30 days after your purchase date. In case of a conflict with this summary, the terms and conditions set forth in the complete Limited Warranty will prevail.

### IMPORTANT INFORMATION

Some options may slightly alter installation. **To ensure proper installation, review this document thoroughly and verify rough-ins before beginning any work.** File this document with the owner or maintenance personnel upon completion of installation.

Sloan products are designed in accord with applicable National Codes and Standards, which may include UPC, ANSI, and ASSE. Installers should use industry standard practice for details not covered within this document. ANSI, UFAS or ADA compliance is subject to the interpretation and requirements of the local code authority and is the responsibility of the installer for verification.

**Prior to installation, supply lines must be flushed of all foreign material such as pipe dope, chips, or solder.** Debris or foreign material in water supply may damage valve. An appropriate thread sealant is recommended on all MPT threaded waste and supply connections to reduce the possibility of leaks. Thread sealant NOT recommended for slipjoint or gasketed connections.

Industry standard wall backing substrate, for wall hung fixtures, is required. Installer provided wall anchors and wall anchoring hardware must be appropriate for wall construction and be able to support three (3) times the weight of the unit.

Electrical receptacle(s) must be wired to a GFCI protected circuit. Fixture must be earth grounded per NEC (National Electrical Code). It is common for electrical equipment to be grounded to water lines either within a structure or away from it. Every attempt should be made to prevent this kind of grounding creating electrolysis. Electrolysis will cause a metallic taste or cause water metal content to increase.

**NOTICE:** A dielectric coupling must be used to connect the water cooler to the water supply. A nonmetallic coupler is furnished with this water cooler to meet this requirement.

## IMPORTANT INFORMATION, CONTINUED

- This fixture is intended for **indoor use only** and is not recommended for installation in environments where freezing temperatures or saltwater may be present.
- Water supply service stop valve, water connections and electrical connections (not provided) must be in accordance with local codes.
- Waste is 1-1/4" Outer Diameter. Water supply is 3/8" Outer Diameter copper pipe.
- To prevent excessive condensation due to cold waste water, Sloan recommends that waste piping provided by installer be insulated appropriately.
- Bottle Filler is designed to not interfere with taste, odor, color, or sediment of water supply. Optional Water Filter is available should any of these problems arise from the water supply. See part number on page 11.
- All burrs must be removed from outside of cut tubes before inserting into components.
- Fixture operates within water pressure range of 20 psi (138 kPa) to 105 psi (724 kPa). Sloan will not warranty product damaged when connected to supply lines with flow pressure lower than 20 psi (138 kPa) or higher than 105 psi (724 kPa). A pressure regulator must be furnished (not provided) on supply line if inlet pressure is greater than 105 psi (724 kPa). **Consult with UPC and local codes for maximum allowable water pressures; many building codes list maximum static water pressure at 80 psi (551 kPa).**
- Per UPC 609.10 – All building water supply systems in which quick acting valves are installed shall be provided with devices to absorb the hammer caused by high pressure resulting from the quick closing of the valve. These pressure-absorbing devices must be approved mechanical devices. Water pressure-absorbing devices must be installed as close as possible to the supply stop.
- **WARNING:** Warranty is voided if installation is not made following current Sloan installation instructions and if components are assembled to the fixture that are not approved by Sloan.

## PRIOR TO INSTALLATION

1. Read installation instructions carefully and completely before proceeding.
2. Use caution when handling units as sharp edges may be present.
3. Provide mounting surface, adequate to support three (3) times the weight of the fixture (81 lbs.).
4. Provide rough-ins as shown on the rough-ins and dimensional drawing, including water supply and drain pipe. (See **Rough-in**).
5. It is common for electrical equipment to be grounded to water lines either within a structure or away from it. Every attempt should be made

to prevent this kind of grounding from generating electrical feedback into the water creating electrolysis. Electrolysis will cause a metallic taste or cause water metal content to increase.

6. Electrical Receptacle(s) must be wired to a GFCI protected circuit. Fixture must be earth grounded per NEC (National Electrical Code).
7. **Completely flush water supply lines of all foreign debris**, before connecting to the fixture.

## TOOLS REQUIRED FOR INSTALLATION

- 5/32" Allen Wrench (not provided)
- Anchoring hardware for  $\varnothing 7/16"$  holes in Step 2F (not provided)
- Phillips head screwdriver (not provided)
- Power drill (not provided)
- Level (not provided)
- Universal Maintenance Tool (provided)



Universal Maintenance Tool  
**DO NOT DISCARD!**

## DIMENSIONAL DRAWING

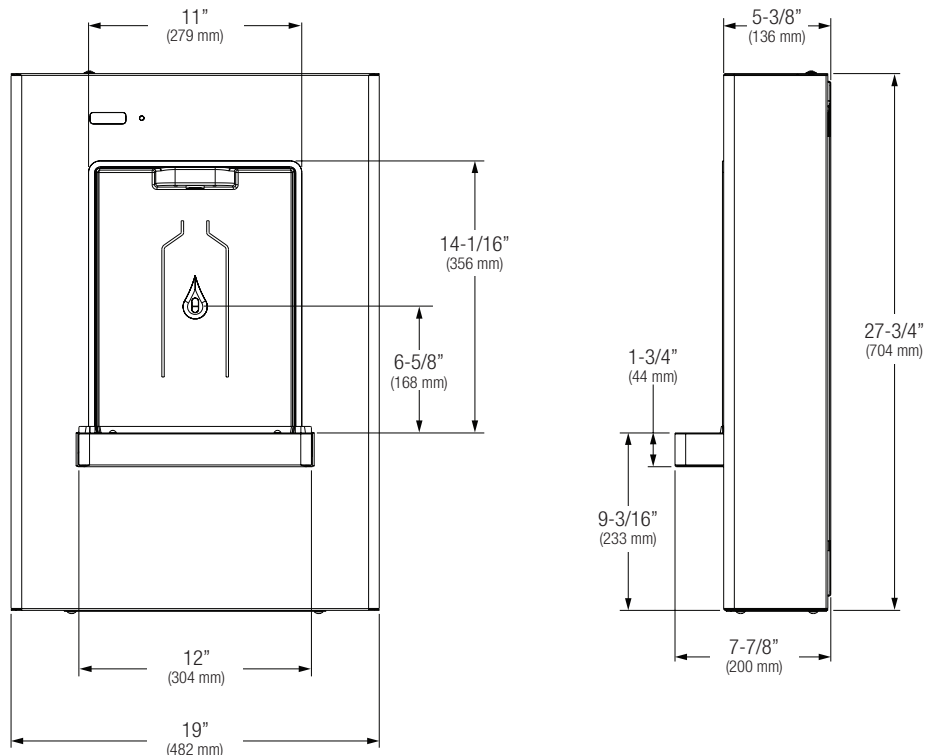

## ROUGH-IN

Prior to roughing in, consult local, state, and federal codes for proper mounting height.

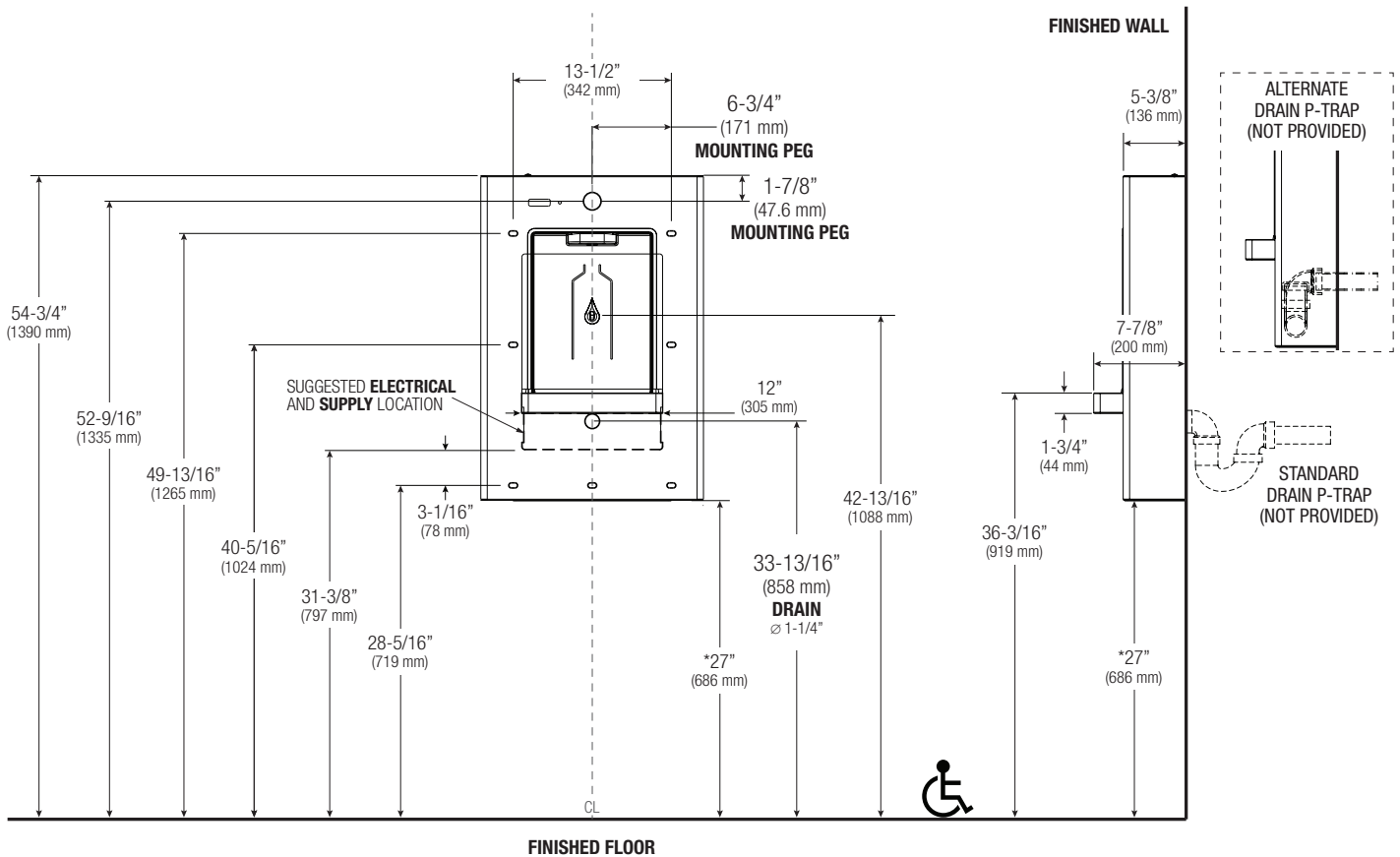

### NOTES:

- All dimensions are shown in inches (mm).
- Dimensions shown for Adult ADA compliant installation. For Child ADA compliant parallel approach installation, decrease height of installation by 3 inches. Provide clear floor space as required. Adjust vertical dimensions as required to comply with federal, state, and local codes.
- Provide 6-1/2" of clearance to left of the unit to allow for opening of the bottle filler housing.
- Waste P-Trap, Water Supply Service Angle Stop Valve and 2" x 4" Electrical Plug-In Receptacle (not provided) must be installed in accordance with local codes.
- If using the standard drain, the P-Trap (not provided) must be installed in the wall behind the drain pan connection. If using the alternate drain tray (sold separately), the P-Trap (not provided) must be installed below the drain pan connection and within the bottle filler housing. Drain outlet in the wall may need to be located within the confines below the alternate drain pan, left or right side of center.
- Dry weight of unit: 27 lbs.

# TUBING AND WATERPATH

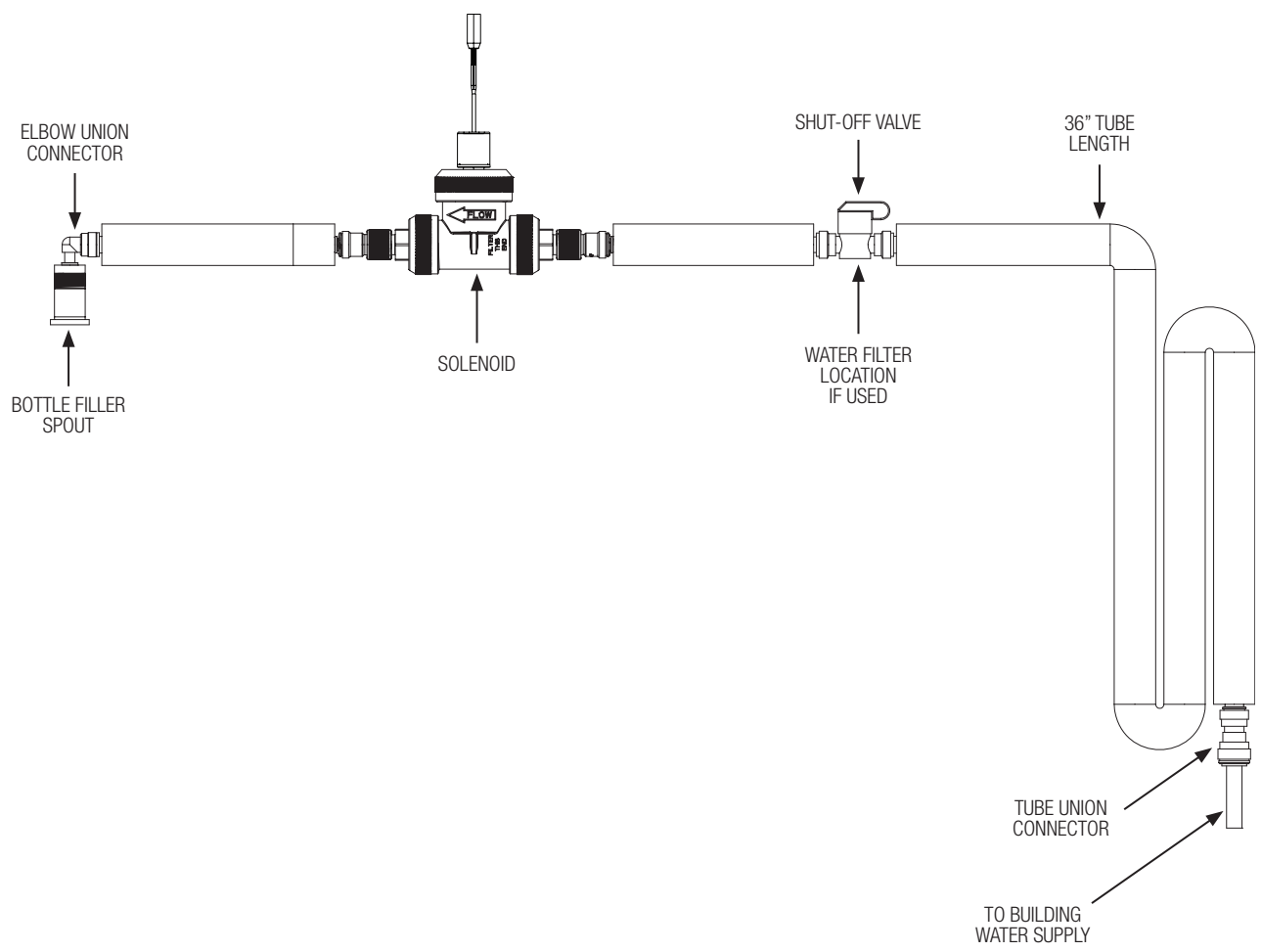

# ELECTRICAL REQUIREMENTS AND CONNECTIONS

**Electrical Requirements:**

- Provide Receptacle on GFCI Protected Circuit
- 115VAC, 60Hz, 5A

Electrical outlet and furnished power cord with plug must be used to supply power to fixture.

Electrical Receptacle must be wired to a GFCI protected circuit. Fixture must be earth grounded per NEC (National Electrical Code).



*Bottle Filler Power Supply*

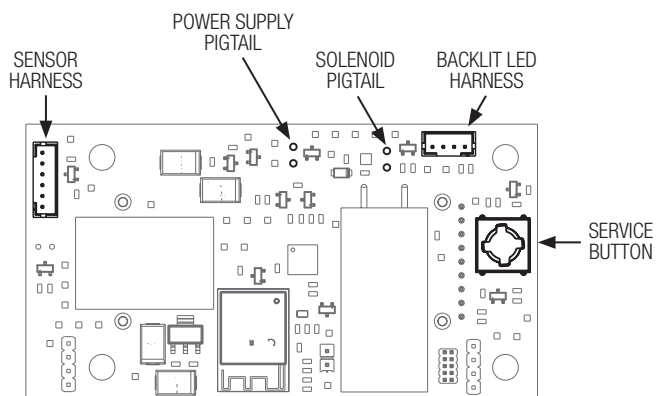

*Bottle Filler Control Board Rear View*

## PUSH-IN FITTINGS

**NOTE: FITTINGS AND TUBE SHOULD BE KEPT CLEAN, BAGGED, AND UNDAMAGED PRIOR TO INSTALLATION.**

### TO CUT TUBE

If needed, use common PE tubing cutters, scissors, or a razor blade to cut to fit length of 1/4" tubing and remove any burrs or sharp edges. Ensure that the outside diameter is free from score marks. Tube ends should be square.



### INSERTING THE TUBE

- 1 Firmly and fully insert the tubing end into the push-in fitting up to the tube stop located approximately 1/2" deep.
- 2 Pull on the fitted tubing to ensure it is secure. Tube should not come free from the fitting. Water test the connection assembly to ensure there are no leaks.

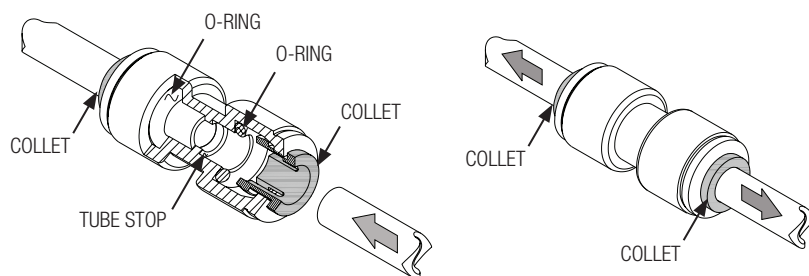

### DISCONNECTING THE TUBE

To disconnect the tube from the fitting, ensure that the water line is depressurized. Use the Sloan Universal Maintenance Tool to push collet square/evenly towards the push-in fitting body and hold. While holding the collet in, pull on the tubing to remove from the push-in fitting.

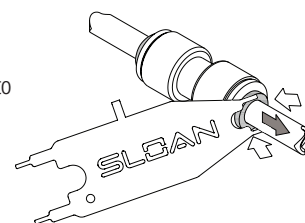

## 1 – INSTALLATION PREPARATION

**IMPORTANT:** Prior to Bottle Filler installation, adequate structural support in or behind the wall, water supply, drain, and electrical must be installed.

All plumbing should be installed in accordance with applicable codes and regulations. All electrical wiring should be installed in accordance with national and local codes and regulations. Electrical outlets should be recessed and installed prior to fixture installation.

### A Adequate Wall Support

Industry standard wall backing substrate for wall hung fixtures is required. Installer provided wall anchors and wall anchoring hardware must be appropriate for wall construction and be able to support three (3) times the weight of the unit (81 lbs.).

### B Water Supply

3/8" OD Supply Inlet.

### C Drain Line

1-1/4" OD Waste Outlet. The P-Trap (not provided) must be in the wall behind the drain pan connection unless using the alternate drain tray (sold separately). See Rough-In.

### D Electrical

Receptacle must be GFCI protected. Fixture must be earth grounded per National Electric Code (NEC).

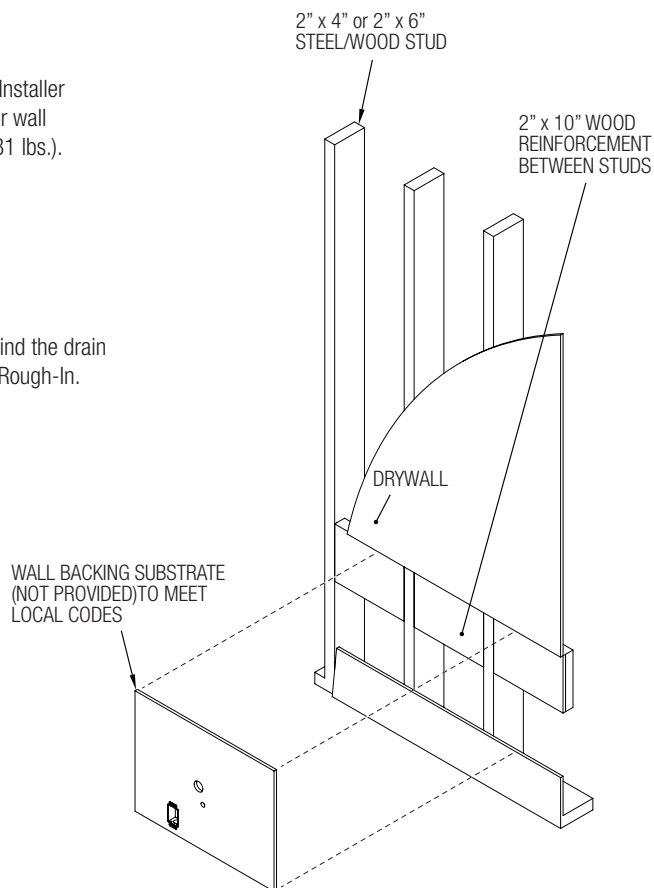
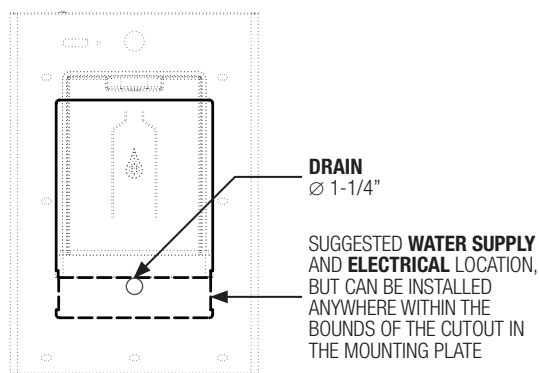

## 2 – INSTALL BOTTLE FILLER

**A** Remove bottle filler unit, plastic mounting peg, and power supply from packaging, use care to avoid damage to fixture and fixture sub assemblies.

**B** Unscrew the top screw with a 5/32" Hex driver or Allen wrench (not provided) and place in a secure location for later use.

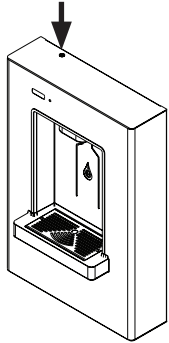

**C** Open the unit by first pulling the left edge of the bottle filler housing away from the backplate and then lifting upward the right side to disengage from the mounting frame assembly and then swinging open the assembly.

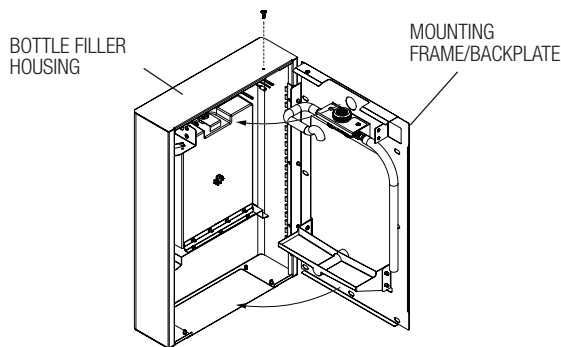

**D** Determine location for mounting peg. Use fastener provided to secure mounting peg to wall. Use additional mounting hardware (not provided) to support the unit's weight.

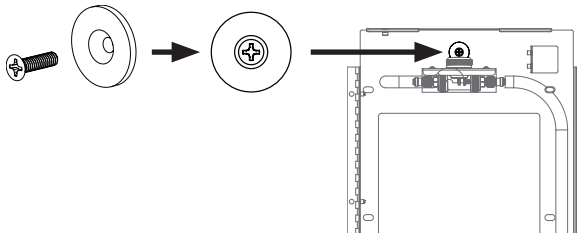

**E** Hang unit on wall and ensure it is level. Mark remaining mounting holes.

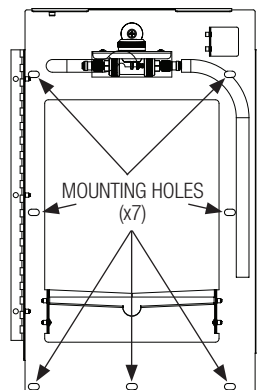

**F** Secure unit to wall with appropriate mounting hardware (not provided).

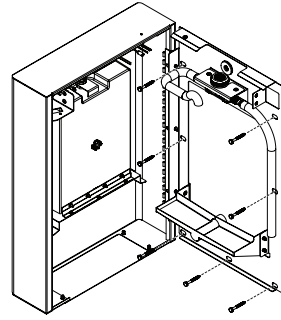

**G** With unit attached to wall, and bottle filler assembly open, install P-Trap waste outlet (not provided).

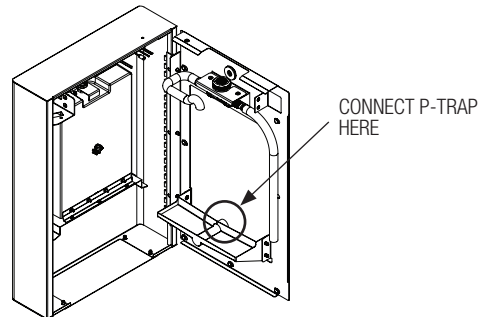

**If using the alternate drain tray (33830045), install P-Trap waste outlet (not provided) and connect to the drain tray.**

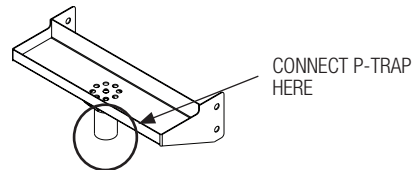

**H FOR FILTERED UNITS:** Install water filter by following instructions packaged with the filter.

**FOR UNFILTERED UNITS:** Connect to water supply.

**I** Connect bottle filler power supply to pigtail connection on the back of the control board and plug power the supply into electrical outlet. Secure wire with cable clamp.

Approximately 12 seconds after power up, the backlit LED lights will illuminate and the counter display will show the number of bottles saved. Bundle excess cord length if necessary.

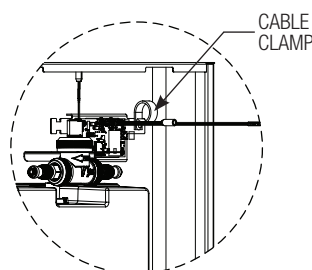

## 2 – INSTALL BOTTLE FILLER, CONTINUED

- J** Connect the solenoid end connector to the solenoid pigtail connector on the control board.
- K** Turn on water. Note that a small amount of water may come out of the bottle filler spout.
- IMPORTANT:** Thoroughly inspect all unit connections for water leaks.

- L** Close the unit by reversing Step 2C. Securing the unit may require a firm push to get the left side flush with the wall.

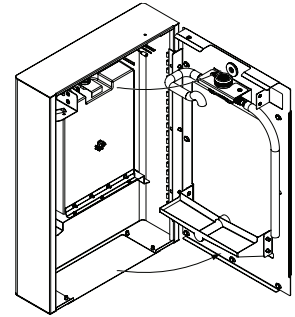

## 3 – BOTTLE FILLER STARTUP

- A** Air within the Bottle Filler will cause an irregular spout stream until purged out by incoming water. Activate sensor until steady water stream is achieved. Hold a cup directly below the filler spout to prevent excessive splashing.
- IMPORTANT:** Ensure unit is closed prior to purging, as the drain tray needs to be above the waste catch to prevent water from spilling.

### For Filtered Units Only:

Run 6.25 gallons through filter before use.

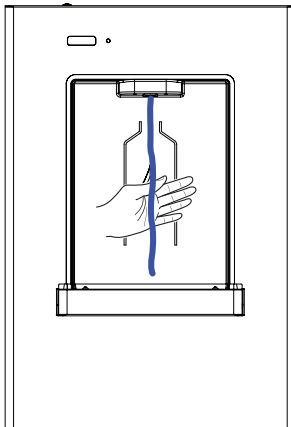

- B** Open the unit as described in Step 2C.

- C** **Set Filter Status**  
**Set new 3000 gal filter (filtered units)** – Press service button for 3 seconds and release once “Reset Filter” is displayed on screen. Quickly press and release button to change display to “Filter 3000”. Wait 6 seconds until display returns to the bottles saved value.  
**Unfiltered units** – Press service button for 3 seconds and release once “Reset Filter” is displayed on screen. Hold button for 3 seconds and release once “Filter NONE” is displayed on the screen. Wait 6 seconds until display returns to the bottles saved value.

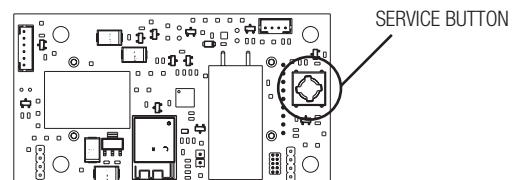
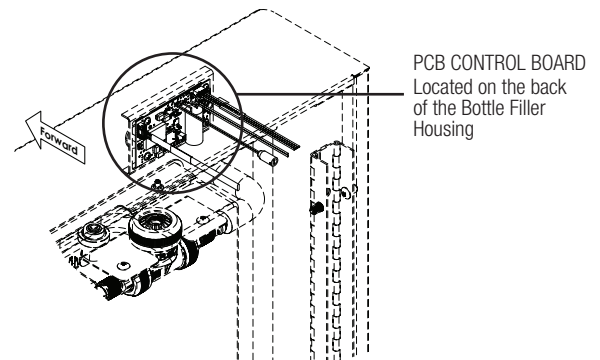

### Sensor Range Adjustment

Refer to the Adjustments & Settings section in the Repair Parts & Maintenance Guide for instructions: [sloan.com/commercial-bathroom-products/bottle-fillers/dropspot/drs100](http://sloan.com/commercial-bathroom-products/bottle-fillers/dropspot/drs100)

- D** Close the bottle filler housing as described in Step 2L. Secure using screw from Step 2B. Do not overtighten.

## CARE AND CLEANING

**IMPORTANT: DO NOT MIX CLEANING SOLUTIONS. ALWAYS READ CLEANING PRODUCT LABEL FOR PROPER USE.**

### FOR STAINLESS STEEL UNITS

Use only a mixture of clean water and a mild detergent to clean unit weekly or more often as needed. For best results, always rinse well with fresh water and wipe completely dry with a clean soft cloth. **DO NOT USE** harsh chemicals, abrasive, or petroleum based cleaners. Use of these will void the Sloan warranty. To remove stubborn water marks or minor scratches, apply a stainless steel cleaner/polish to a synthetic abrasive pad and carefully rub the panel with the grain. **ALWAYS RUB IN THE DIRECTION OF THE GRAIN.** To disinfect stainless steel surfaces, use a solution of clean water and rubbing alcohol. Spray solution onto a soft cloth and wipe down the surfaces of the Bottle Filling Station. Wipe completely dry with a separate clean, dry cloth. Be sure to always wipe or rub **in the direction of the grain** to maintain the finish.

### FOR NON-STAINLESS STEEL UNITS

Use only a mixture of clean water and a mild detergent to clean unit weekly or more often as needed. For best results, always rinse well with fresh water and wipe completely dry with a clean soft cloth. **DO NOT USE** harsh chemicals, abrasive, or petroleum based cleaners, abrasive brushes or pads, or hot water/cleaning solutions. Use of these can damage the finish causing corrosion and will void the Sloan warranty.

## TROUBLESHOOTING GUIDE

**IMPORTANT: BEFORE MAKING ANY OF THE REPAIRS LISTED, ENSURE PROPER ACCESS TO THE ELECTRICAL SUPPLY AND THE WATER SUPPLY VALVE IN THE EVENT THEY ARE NEEDED.**

### 1. RESTRICTED OR NO WATER FLOW:

- A. Ensure water supply service stop valve is fully open.
- B. Verify minimum 20 psi supply line flow pressure.
- C. Check for twists or kinks in outlet tubing.
- D. Ensure there is power to the transformer by checking connections and for loose or cut wires.
- E. Check if bottle filler spout is clogged. If so, remove, clean, and reinstall.
- F. Check if the solenoid filter is clogged. If so, remove, clean, and reinstall filter. Turn off water supply at stop. Remove water supply line from inlet side of solenoid valve. Remove cap, water line fitting, gasket, filter housing, and filter from solenoid valve housing. Slide filter off filter housing. Clean filter using fresh tap water only. If necessary, use a small brush to clean. Use caution while cleaning to prevent damage to filter. If any filter components are damaged, replace as necessary. Reinstall filter on filter housing. Install filter housing, gasket, water line fitting, and cap onto solenoid valve housing. Tighten cap securely. Reinstall water supply line to inlet side of solenoid valve.
- G. For filtered units, check water filter. Replace if necessary.

### 2. BOTTLE FILLER DOES NOT DELIVER ANY WATER WHEN ACTIVATED:

- A. Confirm that solenoid valve produces an audible "CLICK." If it doesn't, then move to 2F.
- B. Check if water supply stop is closed. If so, open supply stop.
- C. Check if shut-off valve is closed. If so, open shut-off valve.
- D. Bottle filler spout is clogged. Remove and clean.
- E. If solenoid valve DOES NOT produce an audible "CLICK," then check the following.
- F. Check if DC power adapter is disconnected. If power adapter is not disconnected, then power cycle by unplugging the power adapter and plugging it back into the unit.
- G. Confirm that power is being supplied to the sensor. Check solenoid cable harness connection to PCB. See wiring diagram on page 4.
- H. Sensor failure. Red LED sequence on sensor (see SENSOR LED DIAGNOSTIC PATTERNS). Replace sensor.

### 3. BOTTLE FILLER DOES NOT STOP DELIVERING WATER OR CONTINUES TO DRIP AFTER USER IS NO LONGER DETECTED (AUTOMATIC SHUT-OFF FAILS EVEN WHEN POWER IS DISCONNECTED):

- A. Check if solenoid valve is connected backwards. If so, disconnect solenoid valve compression fittings at both the inlet and outlet positions. The water should flow from inlet through the solenoid valve to the outlet according to the direction of the arrow shown on the side of the solenoid valve. Reconnect the compression fittings in the correct orientation.

### 4. BACKLIT LEDS ARE OFF OR FLICKERING:

- A. Check if bottle filler spout harness is disconnected. Check bottle filler spout cable harness connection to PCB. Replace harness if problem persists. See wiring diagram on page 4.

### 5. COUNTER DISPLAY OFF OR DISPLAYING "INVALID SENSOR":

- A. Power cycle the unit by unplugging the power adapter and plugging it back in.
- B. Confirm that the sensor harness is not disconnected.
- C. If the unit has been serviced, ensure the correct sensor was installed.

### SENSOR LED DIAGNOSTIC PATTERNS:

Red LED Pattern on Sensor	Pattern Meaning	Action
Single 1 second long blink at startup	Beginning startup sequence	N/A
3 separate quarter-second blinks with half-second blinks between each blink. 1.25 seconds after the 3 blinks before pattern starts again	Sensor invalid/failure	Check sensor harness, power cycle unit, replace sensor
0.05 second blinks every quarter-second	Target detected (only occurs in the first 10 minutes after power up)	N/A

**When assistance is required, please contact Sloan Technical Support at 1.888.SLOAN.14 or 1.888.756.2614.**

## FCC COMPLIANCE

CAUTION: Changes or modifications not expressly approved could void your authority to use this equipment. This device complies with Part 15 of the FCC Rules. Operation to the following two conditions: (1) This device may not cause harmful interference, and (2) this device must accept any interference received, including interference that may cause undesired operation. Note: This equipment has been tested and found to comply with the limits for a Class C digital device, pursuant to part 15 of the FCC Rules.

## INDUSTRY CANADA STATEMENT

This device complies with Industry Canada license-exempt RSS standard(s). Operation is subject to the following two conditions: (1) this device may not cause interference, and (2) this device must accept any interference, including interference that may cause undesired operation of the device. Le présent appareil est conforme aux CNR d'Industrie Canada applicables aux appareils radio exempts de licence. L'exploitation est autorisée aux deux conditions suivantes : (1) l'appareil ne doit pas produire de brouillage, et (2) l'utilisateur de l'appareil doit accepter tout brouillage radioélectrique subi, même si le brouillage est susceptible d'en compromettre le fonctionnement. et votre corps. Cet appareil et son (ses) antenne (s) ne doivent pas être co-localisés ou utilisés conjointement avec une autre antenne ou un autre émetteur.

# PARTS LIST

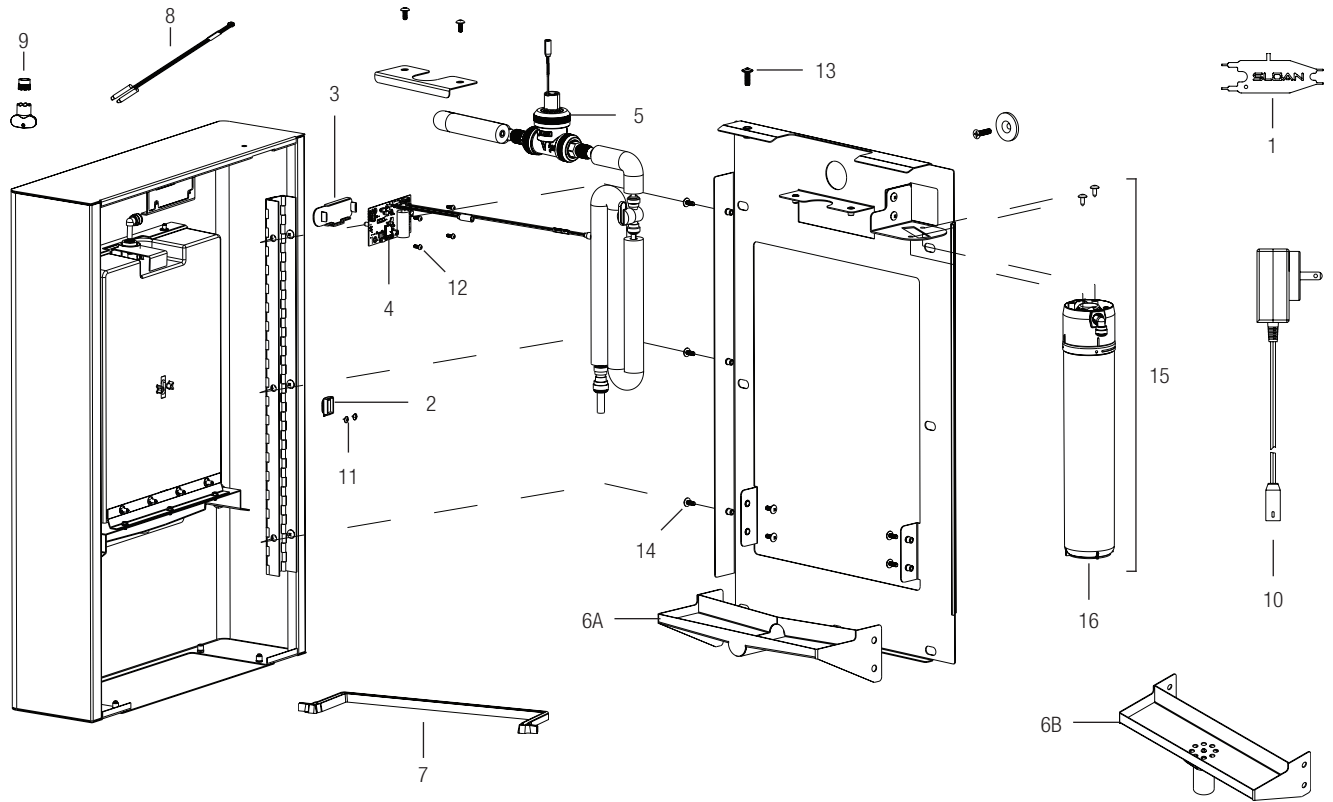

Item No.	Code No.	Part No.	Description
1	33830015	BFS-1	Universal Maintenance Tool
2	33830011	BFS-26	Sensor Replacement
3	33830025	BFS-11	Counter Display Cover Replacement
4	33830039	BFS-23	Sensor PCBA Control Board - DRS-100
5A	63820001	BFS-1001A	Solenoid Valve Assembled
5B	3344001	ELG-1002	Solenoid Valve Repair Kit
5C	33830046	—	Solenoid Replacement Kit
6A	—	—	Standard Drain Tray
6B†	33830045	—	Drain Tray Alternative (for applications with P-Trap in Unit)
7	33830028	BFS-14	Splash Gasket Replacement DRS-100
8	33830012	BFS-27	Spout Outlet LED
9	33830026	BFS-12	1.2GPM Laminar Sprayhead Replacement
10	33830034	BFS-22	110-240 VAC/6 VDC Power Supply

† Sold Separately

Item No.	Code No.	Part No.	Description
11	—	—	Sheet Metal Screw, #6x. 188, Truss Head S/S (Qty 2)
12	—	—	S/S Philips Round Head Screw, #6-32 UNC X 3/8" (Qty 4)
13	—	—	1/4"-20 X 3/4" Flanged Button Head Screw (Qty 1)
14	—	—	#10-32 X 3/8: S/S Truss Philips Head Screw (Qty 2)
15	33830001	FA3000-DRS100	Optional PFAS Water Filter Upgrade Kit
16A	33830003	FC3000R	Optional PFAS Water Filter Replacement Filter - 1 pack
16B	33830014	FC3000M	Optional PFAS Water Filter Replacement Filter - 20 pack
—	33820049	DRS100-UNFIL-UNREF-SS	Full Unit - Non-Filtered, Un-Refrigerated, Stainless Steel
—	33820053	DRS100-UNFIL-UNREF-BLK	Full Unit - Non-Filtered, Un-Refrigerated, Black
—	33820050	DRS100-FIL-UNREF-SS	Full Unit - Filtered, Un-Refrigerated, Stainless Steel
—	33820054	DRS100-FIL-UNREF-BLK	Full Unit - Filtered, Un-Refrigerated, Black

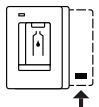

**Register your Sloan DropSpot™ Bottle Filler.**

Go to [sloan.com/register](https://sloan.com/register) or scan the QR code and enter your serial number found inside unit.



The information contained in this document is subject to change without notice.

**SLOAN • 10500 SEYMOUR AVENUE • FRANKLIN PARK, IL 60131**

Phone: +1.800.9.VALVE.9 or +1.800.982.5839 • Fax: +1.800.447.8329 • [www.sloan.com](http://www.sloan.com)