

Vacuum Breaker Trap Primer



ROYAL® FLUSHOMETER MODELS

- (Features high back pressure vacuum breaker)
- **VBF-72-A1**
- **VBF-73-A2** with 2" (50 mm) offset

REGAL® FLUSHOMETER MODELS

- **VBF-72-A2**
- **VBF-73-A2** with 2" (50 mm) offset

The Sloan vacuum breaker trap primer provides a constant water seal in a floor drain. Each time the flushometer is activated, a small amount of water is diverted to the floor drain to maintain the water seal. This seal prevents objectionable sewer gases from escaping into the air.

TABLE 1 †

| Code No. | For Royal® or Regal® flushometer Model | "L" Length of Vacuum Breaker Flush Connection | "A" Centerline of Supply to Top of Bowl | "B" Centerline of Supply to Trap Primer Outlet | "C" Critical Line to Trap Primer Outlet |
|---|--|---|---|--|---|
| VBF-72-A1 | | | | | |
| 3396075 | 110/111 † | 8-1/2" (216 mm) | 11-1/2" (292 mm) | 7" (178 mm) | 2-1/4" (57 mm) |
| 3396076 | 113/113-1.6 | 13" (330 mm) | 16" (406 mm) | 11" (280 mm) | 6-1/4" (159 mm) |
| 3396077 | 115/115-1.6 | 21" (533 mm) | 24" (610 mm) | 11" (280 mm) | 6-1/4" (159 mm) |
| 3396078 | 116/116-1.6 | 24" (610 mm) | 27" (696 mm) | 11" (280 mm) | 6-1/4" (159 mm) |
| VBF-73-A2 With 2" (50 mm) Offset | | | | | |
| 3396059 | 115/115-1.6 | 22-1/2" (572 mm) | 25" (635 mm) | 11" (280 mm) | 6-1/4" (159 mm) |

NOTE: For concealed style VB-75-A Trap Primer consult factory.
 † Refer to Figure A for dimensions "A," "B" and "C." Refer to Figure B for dimensions "L" and "C."
 ‡ Consult local codes for approval of the use of the VBF-72-A1 trap primer with flushometer models 110 and 111. Some codes require a minimum distance of 6" (153 mm) between the critical line of the vacuum breaker and the trap primer outlet. In these cases, specify models 113, 115 or 116.

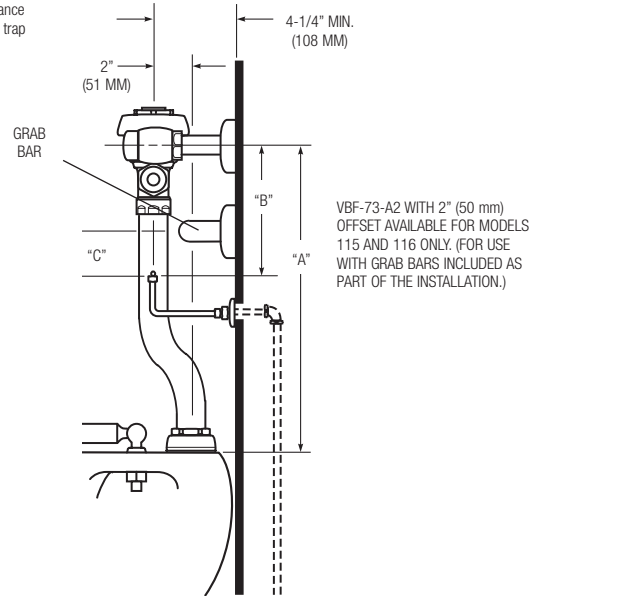
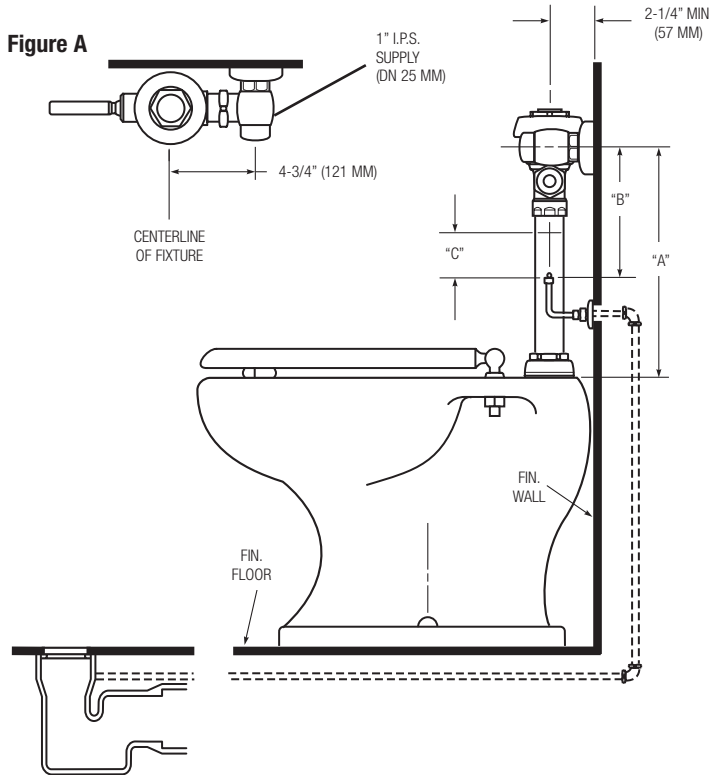

Vacuum Breaker Trap Primer

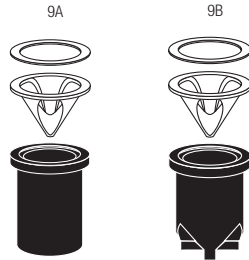
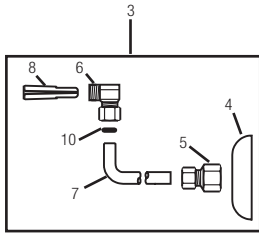
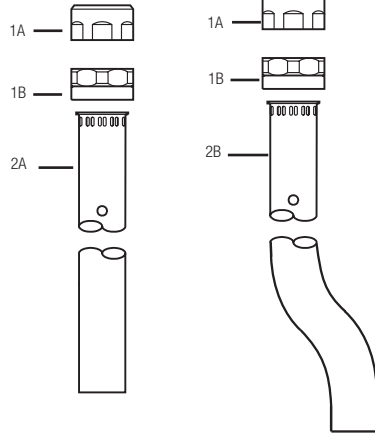
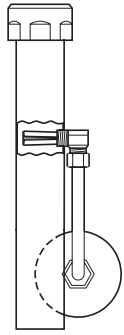

V-651 HIGH BACK PRESSURE VACUUM BREAKER REPAIR KIT



V-551 VACUUM BREAKER REPAIR KIT

PARTS LIST

| Item No. | Code No. | Part No. | Description |
|----------|----------------|----------|---|
| 1A. | 0323304 | V-579 | Vacuum Breaker Coupling for Royal flushometers |
| 1B. | 0323120 | V-553-A | Vacuum Breaker Coupling Assembly for Regal flushometers |
| 2A. | — | VBF-2 | 1-1/2" (38 mm) x "L" Vacuum Breaker Outlet Tube (see Table 1 on page 102 for length) |
| 2B. | — | VBF-4 | 1-1/2" (38 mm) x "L" Vacuum Breaker Outlet Tube with 2" (50 mm) Offset (see Table 1 on page 102 for length) |
| 3. | 0396067 | F-75-AA | Assembly Kit for Trap Primer |
| 4. | 0306164 | F-7 | Wall Flange |
| 5. | 0396083 | F-73-A | Tubing Fitting |
| 6. | 0396084 | F-75-A | Elbow Compression Fitting |
| 7. | 0396085 | F-76 | 3/8" (9 mm) x 12" (305 mm) Flexible Tubing |
| 8. | 0396089 | F-88 | Water Deflector |
| 9A. | 3323182 | V- 651-A | High Back Pressure Vacuum Breaker Repair Kit (standard with Royal flushometers) |
| 9B. | 3323192 | V- 551-A | Vacuum Breaker Repair Kit (standard with Sloan, Regal, GEM2, Dolphin & Naval flushometers) |
| 10. | — | VBF-9 | Restriction Washer |

NOTE: For concealed style VB-75-A Trap Primer consult factory.

Vacuum Breaker Trap Primer

STEP 1 — INSTALL WATER DEFLECTOR AND ELBOW (FIGURE 1)

Insert the smaller end of the black plastic water deflector into the threaded end of the elbow fitting. The flat end of the elbow fitting will face outward from the vacuum breaker.

Place several drops of thread sealant on the threads of the elbow fitting. Insert the elbow fitting and water deflector into the threaded hole of the vacuum breaker tube. Screw the fitting into place. **DO NOT** overtighten this connection. The final position of the elbow should allow water flow from the vacuum breaker in a downward direction.

Figure 1

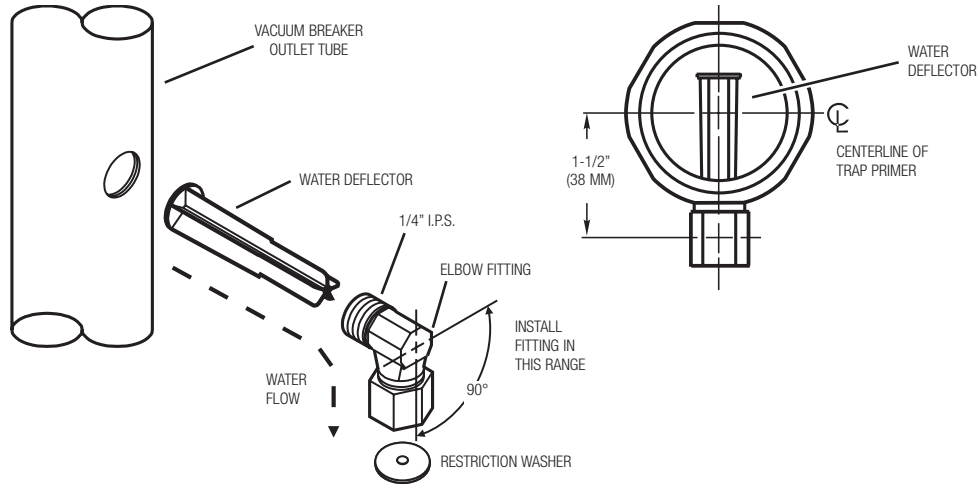

STEP 2 — INSTALL WALL FLANGE (FIGURE 2)

Place wall flange over the 1/2" (13 mm) NPT male pipe used as the trap primer outlet. Push wall flange until it is flush against the wall. Connect the 1/2" (13 mm) NPT female tube fitting to the pipe. The fitting will help keep the wall flange in position.

Figure 2

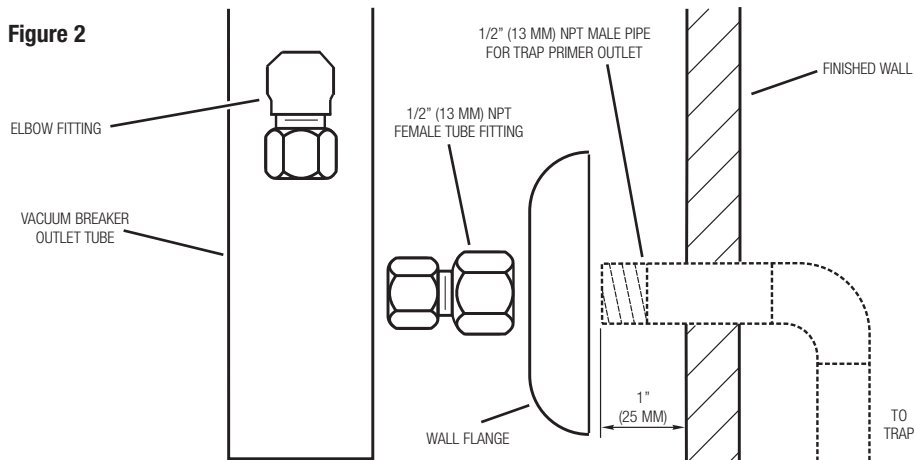

Vacuum Breaker Trap Primer

STEP 3 — INSTALL VACUUM BREAKER FLUSH CONNECTION (FIGURE 3)

Slide the spud coupling, nylon slip gasket, rubber gasket and spud flange (all supplied with a standard flushometer vacuum breaker) over the vacuum breaker tube and insert the tube into the fixture spud. Tighten the spud coupling onto the fixture spud by hand.

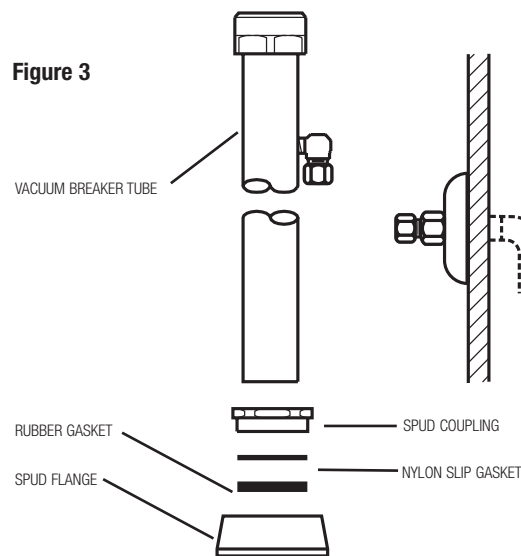

STEP 4 — INSTALL FLEXIBLE TUBING (FIGURE 4)

Use the 3/8" (9 mm) diameter flex tubing to connect the bottom of the elbow fitting with the restriction washer and the tube fitting at the wall flange. Sloan provides a 12" (305 mm) length of flex tubing. Cut tubing to appropriate length. Tighten compression fittings at both ends of the flex tubing. Complete the valve installation according to the installation instructions included with your Sloan flushometer valve.

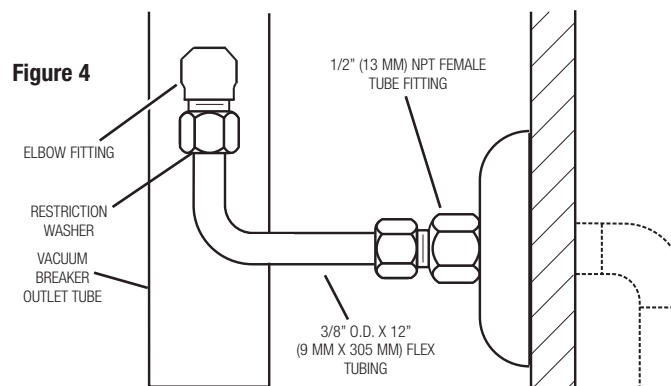

CARE AND CLEANING INSTRUCTIONS

DO NOT USE abrasive or chemical cleaners to clean flushometers, they may dull the luster and attack the chrome finish. Use **ONLY** mild soap and water, and then wipe dry with a clean towel or cloth. When cleaning, protect the exposed flushometer from any splattering of cleaner. Acids and cleaning fluids can discolor or remove chrome plating.