

Optima® EAF-900 Faucet DISCONTINUED

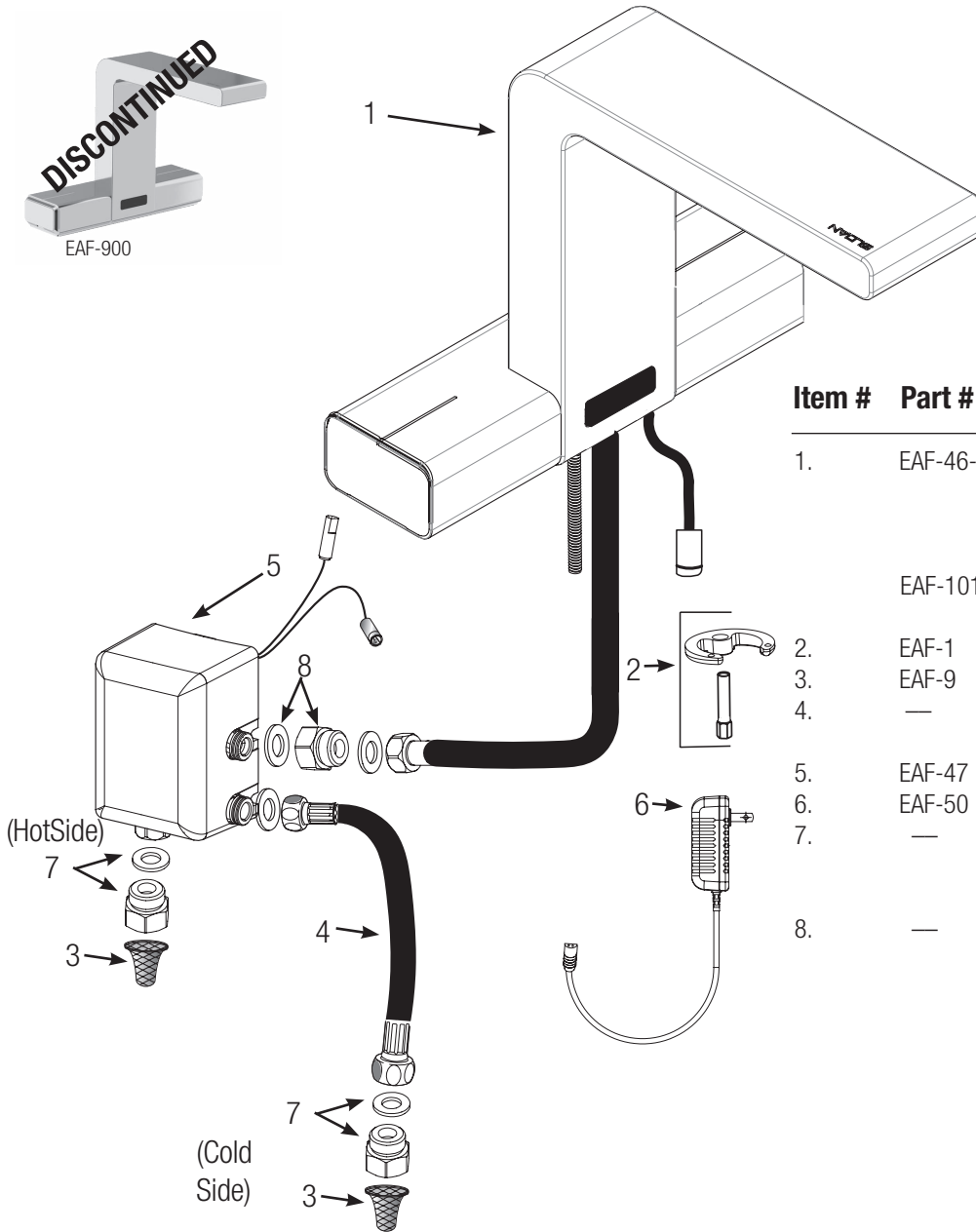

Item #	Part #	Description
1.	EAF-46-A	Spout assembly (includes 0.5 gpm Spray Head, Sensor assembly, Warm and Cold Temperature Adjustments, Hose, Strainer)
	EAF-1010	0.5gpm (1.9 Lpm) Spray Head (not shown)
2.	EAF-1	Faucet Mounting Kit
3.	EAF-9	Strainer (Filter)
4.	—	13" (330 mm) Flexible Supply Hose 3/8 NPSM X 3/8 NPSM (G3/8XG3/8)
5.	EAF-47	Control Module
6.	EAF-50	Transformer 100-240 VAC/12 VDC-1A
7.	—	Supply Fittings and Gaskets (3/8 compression female x 3/8 NPSM-G3/8)
8.	—	0.5 gpm Flow Restrictor Fitting & Gasket

Optima® EAF-900 Faucet DISCONTINUED

1. Faucet does not function properly.

- A. pause mode is activated.
End pause mode.
- B. Water Supply stop(s) closed.
open water supply stop(s).
- C. Filter is clogged.
Clean the filter.

2. Faucet does not stop delivering water or continues to run after user is no longer detected.

- A. Reflection.
Set the sensor range or activate automatic sensor adjustment.

3. The water temperature is too hot or too cold on a faucet connected to hot and cold water supply lines.

- A. Supply stops are not adjusted properly.
Adjust supply stops.

4. Faucet delivers water continuously.

- Contact Sloan Technical Support.

5. leak at fittings.

- A. Ensure gaskets are installed between fittings for 3/8" compression to g3/8".
- B. Tighten fittings.

When assistance is required, please contact
Sloan Technical Support at:

1-888-SLOAN-14 (1-888-756-2614)