



Repair Parts and Maintenance Guide



Scan here for free maintenance, repair, and technical training videos. Earn great Sloan gear while you learn!



Sloan Plumbing Products Terms

This Repair Parts and Maintenance Guide (“Guide”) is provided by Sloan Valve Company, a Delaware corporation whose principal place of business is at 10500 Seymour Avenue, Franklin Park, IL 60131 (“Sloan” or “we”). Your purchase of products, accessories, and related parts including those set out in this Guide (“Products”) from Sloan constitutes your agreement to be bound by the:

- **Product Terms**, and any terms incorporated therein by reference including the Sloan Minimum Advertised Price Policy, which can be found at: [Sloan.com/terms-and-conditions.pdf](https://www.sloan.com/terms-and-conditions.pdf)
- **Limited Warranty** offered by Sloan, and any terms incorporated therein by reference, which can be found at: [Sloan.com/warranty-information](https://www.sloan.com/warranty-information)
- **Return Policy** offered by Sloan, and any terms incorporated therein by reference, which can be found at: [Sloan.com/warranty-information](https://www.sloan.com/warranty-information)

The above, collectively referred to hereafter as the “Terms.”

Please carefully read the Terms. By purchasing any products you are agreeing to be bound by the Terms.

The Terms in effect at the time you place an order for the Products will apply to such order. Sloan reserves the right to make changes to these Terms from time to time, and any such changes will apply to future orders.

Flushometer Identification

IN ORDER FOR THE WATER CLOSET OR URINAL TO PERFORM PROPERLY FOR ITS INTENDED USE, YOU MUST FOLLOW THESE INSTRUCTIONS:
A. IDENTIFY YOUR FLUSHOMETER MODEL NO.
B. CHECK FOR THE WATER CONSUMPTION LABEL ATTACHED TO FLUSHOMETER AND FIXTURE, ENSURING THEY MATCH.
C. REFER TO SPECIFIC FLUSHOMETER SECTION IN GUIDE FOR APPROPRIATE REPLACEMENT PART NO.

1. IDENTIFY YOUR SLOAN FLUSHOMETER

Identify our Sloan flushometer from the vacuum breaker, cap, cover, or from identification label at the bottom of the valve body. (Sloan parts only supplied.)

Exposed



Concealed



Water Closet



(Check water inlet at top or back of fixture. Typically 3.5 gpf to 1.6 gpf, larger vacuum breaker)

Urinal

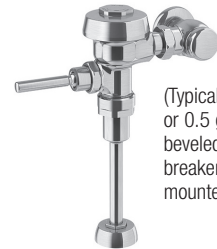

(Typically 1.0 gpf or 0.5 gpf, smaller, beveled vacuum breaker, wall mounted)

Manual Diaphragm Flushometers (Pages 16-26)

Royal®



Royal II®



Continental®



UPPERCUT®



Sloan®



Regal®



Known as Regal® XL (Since mid-2010)

Hydraulic & Concealed Diaphragm Flushometers (Pages 27-35)

Series 900® Exposed



Series 900® Concealed



Concealed



Manual Piston Flushometers (Pages 36-50)

Crown®



Crown II®



DISCONTINUED

Gem-2®



Manual Piston Flushometers (Pages 36-50)

Naval®



TruFlush



Sloan CX



Dolphin®



Manual Self-closing Flushometers (Pages 51-53)

Slimline® Bedpan Washer (Pages 54-56)

For electronic components use Sensor Flushometer Section.

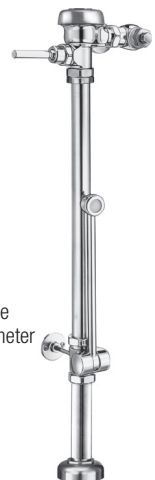

Flushometer Identification

Sensor Activated Hardwired/Battery Flushometers (Pages 57-84)

Optima® Hardwired



Optima® ES-S-WB



Optima® ES-S TMO



SMOOTH® Hardwired



Sloan ECOS® Hardwired



Royal® ESS SWB Hardwired



Optima® Royal® ES-S TMO Concealed



Optima® Royal® ES-S TMO Concealed with SWB



TruFlush Hardwired/Battery (International Only)



Sloan CX Hardwired/Battery (USA & Canada)



Optima® Hardwired 120/24V



Optima® Crown® ESS



Battery/Solar-powered Sensor Activated Flushometers (Pages 85-118)

G2 Optima Plus®



SLOAN® Optima Plus®



DFSM/SFSM



SMOOTH®



SMO



Sloan ECOS®



Sloan SOLIS®



SOLIS® CONCEALED



Accessories/Tools (Page 13)



2. CHOOSE REPLACEMENT PARTS FROM THESE PAGES:

Tools/Accessories.....	13	Flushometer Body Sub-Assemblies.....	129
Manual Diaphragm Flushometers	16-26	Trap Primer	130-133
Hydraulic & Concealed Diaphragm Flushometer	27-35	Small Vacuum Breaker Repair Kits.....	134
Manual Piston Flushometers.....	36-50	Push Buttons.....	135-138
Manual Self-Closing Flushometer.....	51-53	Flush Connections & Flanges.....	139-144
Manual Diaphragm Bedpan Washer Flushometer.....	54-56	Offset Outlet Tubes	145
Sensor Activated Hardwired Flushometers.....	57-84	Bumpers, Pipe & Tube Supports.....	146
Sensor Activated Battery/Solar-Powered Flushometers.....	85-118	Floor Valve.....	147
Control Stops.....	119-126	Sweat Solder Kits.....	148
Tail Pieces.....	127-128	Flushometer Parts Quick Reference Guide.....	149

The information contained in this document is subject to change without notice.

Faucet Identification

IDENTIFY YOUR SLOAN FAUCET AND CHOOSE REPLACEMENT PARTS FROM THE PAGES LISTED:

BASYS® Faucets (Pages 150-172)



EFX-1 (IR) SERIES



EFX-2 (IR) SERIES



EFX-3 (IR) SERIES



EFX-6 (IR) SERIES



EFX-8 (IR) SERIES



EFX-3 (CAP) SERIES



EFX-6 (CAP) SERIES

NEW Bluetooth EBF/ETF Optima® Battery, Hardwire & Turbine Faucets (Pages 173-208)



EBF-85/ETF-80



EBF-187/ETF-880



EBF-650/ETF-600



EBF-615/ETF-610



EBF-750/ETF-700
EBF-750-2/ETF-700-S



EBF-550/ETF-500
EBF-550-2/ETF-500-S



EBF-665/ETF-660



EBF-755/ETF-770



EBF-850/ETF-800



EBF-425/ETF-420



EBF-415/ETF-410



EBF-825/ETF-820



EBF-815/ETF-810

OLD EBF/ETF Optima® Battery, Hardwire Faucets (Pages 209-231)



EBF-85/EBF-187
ETF-80/ETF-880



EBF-650/ETF-600



EBF-615/ETF-610



EBF-625/EBF-655



EBF-750
ETF-700



EBF-550/ETF-500
EBF-550-S/ETF-500-S



EBF-660/EBF-665



ETF-770



ETF-800

Faucet Identification

IDENTIFY YOUR SLOAN FAUCET AND CHOOSE REPLACEMENT PARTS FROM THE PAGES LISTED:

EAF Solar, Battery & Hardwire Faucets (Pages 232-256)



EAF-150/EAF-100



EAF-225/EAF-250/
EAF-200



EAF-275



EAF-350/EAF-300



EAF-750/EAF-700



EAF-900

SF Battery & Hardwire Faucets (Pages 257-266)



SF-2100/SF-2150



SF-2200/SF-2250



SF-2300/SF-2350



SF-2400/SF-2450



SF-2800/SF-2850



SF-2900/SF-2950

Discontinued Faucets (Pages 267-270)



ERF-885



ELF-10



ESF-20/30

Accessories (Pages 271-273)



Trim Plates



Aerators

Vitreous China Fixture Identification

IDENTIFY YOUR SLOAN MODEL AND CHOOSE REPLACEMENT PARTS FROM THE PAGES LISTED:

Water Closets (Pages 280-281)



ST-2459



ST-2469



ST-2009



ST-2029



ST-2229



ST-2309



ST-2449



ST-2359-LR

Pressure Assist and Gravity Water Closets (Pages 282-285)



WETS-8009 Series
STD



WETS-8029 Series
ADA



WETS-4009 Series
STD



WETS-4029 Series
ADA

Washdown, Retrofit, and Small Urinals (Page 286)



SU-1009



SU-1019



SU-1209



SU-1219



SU-7009



SU-7019



SU-7409



SU-7419

Hybrid and Waterfree Urinals (Pages 287)



HYB-1000



HYB-1000-RET



HYB-4000



HYB-7000



WES-1000



WES-4000



WES-7000

Lavatories (Page 293)



SS-3001



SS-3002



SS-3003



SS-3004



SS-3006



SS-3065



SS-3021



SS-3026



SS-3036



SS-3145



SS-3017



SS-3055



SS-3200

Sink System, Soap Dispenser, Hand Dryer, and Showerhead Identification

IDENTIFY YOUR SLOAN MODEL AND CHOOSE REPLACEMENT PARTS FROM THE PAGES LISTED:

Sink Systems (Pages 294-346)



Soap Dispenser (Pages 347-353)



Sink System, Soap Dispenser, Hand Dryer, and Showerhead Identification

IDENTIFY YOUR SLOAN MODEL AND CHOOSE REPLACEMENT PARTS FROM THE PAGES LISTED:

Hand Dryer (Page 354)



EHD-501/502 Series



EHD-701/702 Series

Showerheads (Pages 355-356)



AC-11 Series



AC-51 Series



AC-450 Series



AC-460 Series

FAUCET PRODUCT VARIATION SUFFIXES

ABBREVIATION	DEFINITION	ABBREVIATION	DEFINITION
0.35	0.35 gpm	IR	Infrared Sensor
0.5	0.5 gpm	ISM	Integrated Side Mixer, Integrated Side Mount Mixer
1	1.0 gpm	KIT	Kit
1.5	1.5 gpm	L. CONTL MOD	Less Control Module
2.2	2.2 gpm	L/BATT	Less Batteries
4	4 inch trim plate	L/LOGO	Less Logo
8	8 inch trim plate	LAM	Laminar
10S	10 second timeout	12S	12 second timeout LCM
LB	Less Battery	LCM	Less Control Module
4 in center	4 inch centerset	ADM	Above Deck Mechanical Mixing Valve, Above Deck Mixer
LESS TRIM	less Trim Plate	LF	Line Flush
AER	Aerated LINE	LINE FLSH NYP	Line Flush
ASM	Assembly	LINE FLUSH	Line Flush
B	Box Mount Transformer	LL	Less Logo
B BACKUP	Battery Back-Up	LP	Line Purge
BA	Buy America Act	LR	Long Range Sensor
BAA	Buy American Act	LT	Less Transformer
BAT B	Battery Back-Up	MB	Matte Black
MLM	Multi-Laminar Spray	BDM	Below Deck Mechanical Mixing Valve
NON	None - No Sprayhead	BDT	Below Deck Thermostatic Mixing Valve
P	Plug-In	BN	Brushed Nickel
PB	Polished Brass	PED	Pedestal Body Style
BOX	Box Adaptor or Transformer	CAP	Capacitance PLG Adapter Plug
Chek	Chek Tee	PRX	Proximity
CP	Polished Chrome, Finish Chrome Plated	PVDBN	PVD Brushed Nickel Finish
CT	Chek Tee	PVDMB	PVD Matte Black
DPU	Drain Pop Up	PVDPB	PVD Polished Brass Finish
EAF	Electronic Above-Deck Faucet	PVDSB	PVD Satin Brass Finish
EBF	Electronic Battery Faucet	PVDSF	PVD Brushed Stainless Finish
EFP	Electronic Faucet Part	S	Surgical (Hospital) Bend Spout
EFX	Electronic Faucet Generation X (BASYS)	SF	Sloan Faucet Product Family
EL 3500	EL 3500 Sensor	SF	Brushed Stainless
ETF	Electronic Transformer Faucet	EXT	Extension SOL Solar
SHR	Shower Shower Head Attached	F	Flow Restrictor TEE Back Check Tee
FCT	Faucet	G'NECK	Gooseneck WS Wash Station
TUR	Turbine	H	Showerhead Type Spray Unit
GOOSENECK	Gooseneck	HLT	Hardwired Less Transformer
HLP	Hardwired Less Plug	IC	IC Click Feature
HW	Hardwired	INTL	International Spec
INT	Integrated Base		
IQ	IQ Click Feature		

SLOANSTONE SINK PRODUCT VARIATION SUFFIXES

SINKS VARIATIONS (40000/50000 Series)

AB	Angle Bracket
ADM	Above Deck Mechanical Mixing Valve
BDT	Below Deck Thermostatic Mixing Valve
DS	Drain Shroud
ESD	Electronic Soap Dispenser
FA	Integrated Front Apron
FL	Floor Mounted
FM	Floor Mount Kit
JVC	Juvenile Height Cabinet
LS	Left Side Splash
MSD	Manual Soap Dispenser
RS	Right Side Splash

VARIATIONS (Designer Series)

AB	Angle Bracket
ESD	Electronic Soap Dispenser
ENC	Enclosure

SINK COLORS (4000 Series)

AH	Ash
AM	Amber
IN	Indigo
JD	Jade
JT	Jet
PL	Pearl
SL	Slate
SS	Sand
TP	Taupe

SINK COLORS (60000/70000/80000 Series)

WH	White
CO	Cameo
BO	Bone
PH	Peach
AL	Almond
SH	Shell
PE	Pea
BI	Biscuit
MWH	Matrix White
MSI	Matrix Silver
MPI	Matrix Pink
MJA	Matrix Jade
MLG	Matrix Light Gray
MDG	Matrix Dark Gray
MGR	Matrix Green
MBR	Matrix Brown
MBO	Matrix Bone
MFR	Matrix Frost
MLB	Matrix Light Blue
MSA	Matrix Sand
MDB	Matrix Dark Blue
MDU	Matrix Dusk
MKH	Matrix Khaki
MSU	Matrix Summit
WNT	Walnut/Riverstone

SINK COLORS (Bio-Deck Series)

CC	Corn Cob
RM	Rustic Maple
G	Grey
JG	Jade Green

MIXING VALVES

ADM	Above Deck Mixing Valve
BDM	Below Deck Mechanical Mixing Valve
BDT	Below Deck Thermostatic Mixing Valve
Check/CT	Check T
ISM	Integrated Side Mixing Valve

FINISHES

CP	Chrome Plated
PVDBN	Brushed Nickel Finish
PVDPB	Polished Brass Finish
PVDSF	Brushed Stainless Finish
PVDGR	Graphite Finish

FAUCET FAMILY

EAF	Electronic Above Deck Faucet
EBF	Electronic Battery Faucet
ETF	Electronic Transformer Faucet
EFX	Electronic Faucet Generation X (BASYS)
SF	Sloan Faucet

MISCELLANEOUS

BAA/BA	Buy American
ASM	Assembly
DPU	Drain Pop up (discontinued)
Ext.	Extension
IC	IC Click Feature
INTL	International Specification
IQ	IQ Click Feature
KIT	Kit
L CONT MOD.	Less Control Module
L/LOGO, LL	Less Logo
LR	Long Range Sensor
WS	Wash Station

SloanStone® Identification

IDENTIFY YOUR SLOANSTONE LAVATORY SINK:

Careful consideration was given to the naming convention for SloanStone® solid-surface lavatories. This page helps explain the logic behind the model names and will help you to be able to identify the product easily and consistently via the model numbers. Please take the time to look through the specification sheets and Sink System brochure to help you better understand the naming convention.

THE PREFIX

Prefixes are used to identify the group/category of Bio-Deck and SloanStone solid-surface lavatory systems. Here are some ways to help you remember the group:

ELS	Electronic Lavatory System	These have a curved basin and Sloan faucets
EW	Electronic Washstation	These have a curved basin and an integrated EL-1500 sensor
ELC	Electronic Lavatory Countertop	These are flat lavatory decks with Sloan faucets
EFW	Electronic Wash Fountain	These have a square type basin and an integrated EL-1500 sensor
ELB	Electronic Lavatory Bio-Deck	These are flat lavatory decks made of biobased material with Sloan pedestal faucets

The sample images below show the various groups/categories of SloanStone lavatory systems

ELS-43XXX/ELS-63XXX/ELS-73XXX

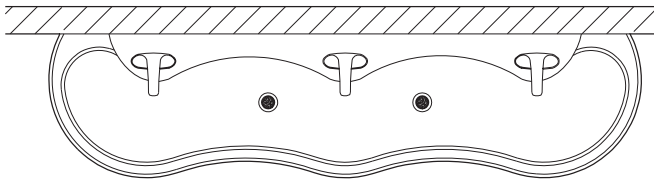

EW-42000*

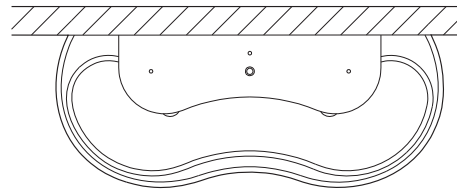

ELC-42XXX/ELC-72XXX/ELB-52XXX

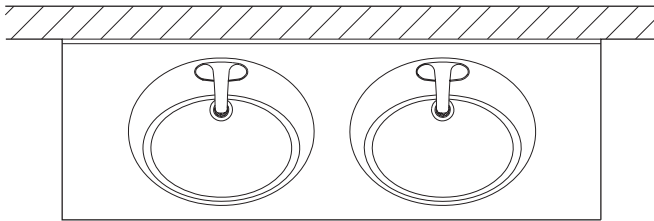

EFW-43000*

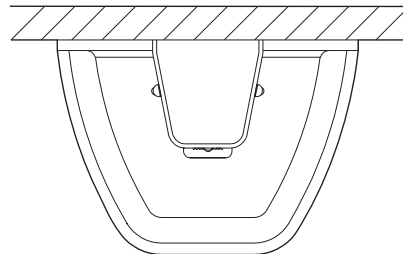

THE NUMBERS

Numbers are used to identify the style of Bio-Deck and SloanStone solid-surface lavatory systems. Let's review the ELS-42650. This is a SloanStone, 2 station lavatory system with a curved basin and two Optima Plus® EBF-650 faucets. The first number is 4. The number 4 denotes the origin as United States. All SloanStone sinks with a 4 or 5 will be Buy American Act Compliant, while 6, 7 and 8 will comply with the Trade Agreements Act. The next number is 2. This number indicates the number of users the sink can service or the amount of stations, which vary from model to model. The next 3-4 digits are used to identify the Sloan faucet that is installed on the unit, or in some cases, to denote that there are not Sloan faucets on the lavatory system, in which case 000 will be the last three digits. ***Both EW and EWF models will always end in 000.**

Let's break down the components of the **ELS-42650**.



Let's break down the components of the **ELB-522150**.



Tools/Accessories

Description

Sloan's A-50 Super-Wrench™ Smooth-jawed spud wrench for various Sloan components is the ideal tool to use when installing or servicing a Sloan Flushometer. Its smooth edges, solid construction and tight grip prevent damage to the valve's finely machined surfaces and plated finishes.

The 7-3/4" A-50 Super-Wrench combines the versatility of several tools into a single wrench. It is the ideal tool for anyone who regularly installs and services Flushometer valves.

Specifications

Unique Super-Wrench is an ergonomic tool that offers good leverage and fast adjustments to Flushometers.

Superior tool for gripping, holding and bending
Multiple wrenches in one Super-Wrench sized to fit the following Sloan parts:

- F-20
- B-40/H-582
- F-20/A-72/A-6
- H-579
- H-577
- H-573
- V-553



Description

Sloan's A-109 Plier Wrench is the ideal tool to use when installing or servicing a Sloan Flushometer. Its smooth jaws and tight grip prevent damage to the valve's finely machined surfaces and plated finishes.

The 12" (305 mm) A-109 Plier Wrench combines the versatility of several pliers with the convenience of a wrench. It is the ideal tool for anyone who regularly installs and services Flushometers.

Specifications

Unique Plier and Wrench in one ergonomic tool offers enormous leverage, fast adjustment, and the following features:

- Cam-action ratcheting mechanism
- 13 preset push button positions
- Maximum jaw capacity across flats: 2-3/8" (60 mm)
- Smooth parallel jaws prevent damage to chrome-plated and special finishes and soft fittings
- Memory button retains jaw opening size for repetitive work
- Self-locking mechanism
- Smooth box joint construction for greater strength
- Superior tool for gripping, holding and bending



Description

Sloan's A-124 Strap Wrench is the ideal tool to use when installing or servicing Sloan's Optima® Plus Battery Operated Flushometers.

The A-124 Strap Wrench is completely adjustable for diameters 1-1/2" to 5" (38 mm to 127 mm). It is easy to use even in tight areas.

Specifications

Urethane-covered belting attached to lightweight, i-beam handle offers industrial strength and the following features:

- Cam-action design permits uniform, high-torque application
- Belting will not scratch, damage or deform polished pipe and fittings under normal conditions
- Ideal for use on all Sloan Flushometers
- Works in the tightest quarters
- Can be ratcheted with one hand
- Prevents damage to chrome-plated and special finishes



Description

Our new H-1018A Offset Adapter for G2, SOLIS®, and ECOS® Flushometers helps keep your facilities accessible. This unassuming adapter creates enough space for an ADA-compliant grab bar by lowering the total height of the flushometer by 1 1/2 inches without having to relocate the water supply inlet pipe. It's a simple update that saves your facility from the costs and complexities of opening walls or workarounds like split grab bars.

Specifications

Solid chrome plated semi-red brass adapter offers the following features:

- Updates flushometers to enable ADA grab bar installation
- Avoids costly wall modifications
- Includes mud guard and flange for easy installation
- Extensively tested for optimal performance and pressure
- Durable, patent-pending design that's easy to maintain
- Available in finishes to match your existing flushometers, including Polished Chrome, Polished Brass, Brushed Nickel, Brushed Stainless, and Graphite
- Industry standard 1" NPT connection to the control stop



Valve Body Inlet and Handle Positions

FLUSH VOLUMES

Sloan Flushometers are precision metering valves designed to deliver a preset volume of water to a sanitary fixture. The amount of water needed in a flush is determined by the fixture being used. The flush volume supplied with Sloan flushometers have been established by United States and International standards.

gpf=Gallons per Flush Lpf=Liters per Flush

WATER CLOSET FLUSHOMETERS

Can be supplied with the following flushing volumes:

- 1.28/1.1 gpf (4.8/4.2 Lpf) Ultra High Efficiency
- 1.6/1.1 gpf (6.0/4.2 Lpf) High Efficiency
- 1.1 gpf (4.2 Lpf) Ultra High Efficiency
- 1.28 gpf (4.8 Lpf) High Efficiency
- 1.6 gpf (6.0 Lpf) Low Consumption
- 2.4 gpf (9.1 Lpf) European Style Bowls
- 3.5 gpf (13.2 Lpf) Water Saver
- 4.5 gpf (17 Lpf) Water Saver
- 6.5 gpf (24.6 Lpf) Service Sink

URINAL FLUSHOMETERS

Can be supplied with the following flushing volumes:

- 0.125 gpf (0.5 Lpf) Ultra High Efficiency
- 0.25 gpf (0.9 Lpf) Ultra High Efficiency
- 0.5 gpf (1.9 Lpf) High Efficiency
- 1.0 gpf (3.8 Lpf) Low Consumption
- 1.5 gpf (5.7 Lpf) Low Consumption

The above flushing variations can be supplied with:

- Royal • Sloan • Regal XL • Gem 2 XL • Crown • Naval • Dolphin
- G2 • ECOS • Solis • CX

Naval and Dolphin are adjustable valves. Flush volumes can be field adjusted to meet specialized needs.

PVD FINISHES

Sloan flushometers for exposed applications are provided with a chrome plated finish as standard. Concealed valves are unplated (rough brass finish) with all exposed components provided chrome plated. Special finishes can be provided for most valve variations.

- Polished Brass "PB" model variation
- Satin finish "SF" model variation
- Brushed Nickel "BN" model variation
- Brushed Stainless "BS" model variation
- Graphite "GR" model variation

HANDLE POSITION

For most exposed applications, Sloan flushometers are supplied with the handle in-line (180°) with the water supply inlet. This allows for the water supply to be rough-in either to the right or left of the valve.

Concealed flushometers are provided with a double handle opening to allow for the water supply to be roughed-in either to the right or left of the valve. The push button assembly is perpendicular (90°) from the water supply opening.

Handle & inlet position can be varied to meet individual user needs.

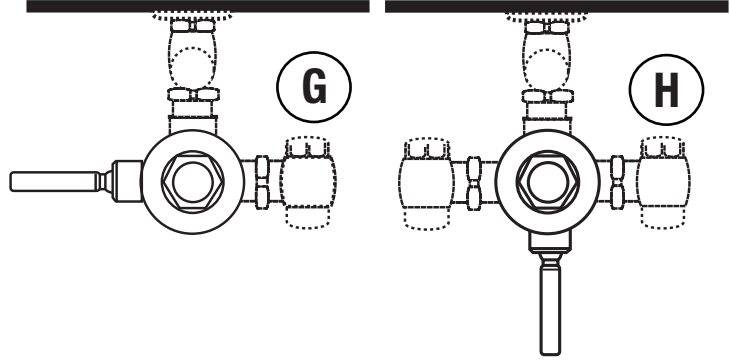

HANDLE POSITION

- G** Handle on left side of valve
- H** Handle on front of valve
- I** Handle on right side of valve

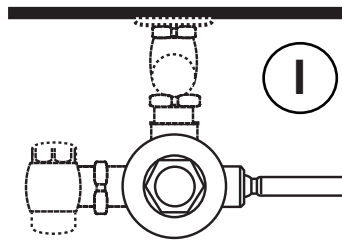

INLET POSITION

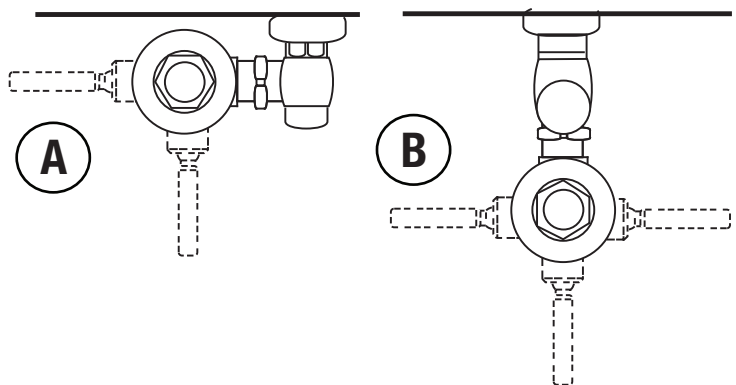

INLET POSITION

- A** Inlet of right side of valve
- B** Inlet on back of valve
- C** Inlet on left side of valve

Flushometer Pressure Gauges

Sloan Flushometer pressure gauges, for measuring static & approximate dynamic water pressure (flowing water pressure).

- **Sloan Diaphragm Flushometer Gauge A-115-A (0301141) for manual, 24/120 VAC solenoid operated & Hydraulic Diaphragm Flushometers**

Rough brass, diaphragm top outside cover, inside cover with attached RB tube w/pressure gauge. For reading static pressure and approximate dynamic (flow) pressure at the valve.

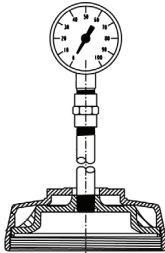

Diaphragm Flushometer Pressure Gauge A-115-A



Optima® 8100 Series Flushometer Pressure Gauge EBV-375-A

- **Sloan Optima® 8100 Series Flushometer Gauge, EBV-375-A (0325378) Works for all SLOAN diaphragm type flushometers since 1906.**

Chrome plated locking ring, nickel plated brass cover, attached RB tube w/pressure gauge. For reading static pressure and approximate dynamic (flow) pressure at the valve. For existing as well as new Sloan diaphragm Flushometers with top mounted sensor.

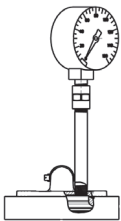

Crown Piston Flushometer Pressure Gauge CR-150-A



GEM 2 Piston Flushometer Pressure Gauge G-150-A

- **Sloan Crown Piston Flushometer Gauge CR-150-A (0332070) for CROWN and CROWN II flushometers since 2002.**

Rough brass cover, inside cover with attached RB tube w/pressure gauge. For reading static pressure and approximate dynamic (flow) pressure at the valve.

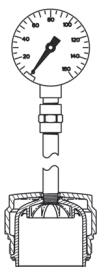

- **Sloan GEM2 Piston Flushometer Gauge G-150-A (0307214) for all GEM and GEM 2 flushometers made since 1929.**

Chrome Plated brass cover and gasket, with attached RB tube w/pressure gauge. For reading static pressure and approximate dynamic (flow) pressure at the valve.

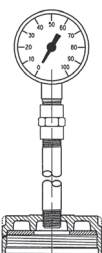

Note: Flushometer Gauge NOT to remain on Flushometer

** Sloan uses a 160 PSI gauge fitted to pressure cap gauge assemblies. Plumbing system pressure shall not exceed 80 PSI; a 160 PSI gauge allows measuring plumbing systems that happen to be above the acceptable range without damaging the gauge; max pressure 160 PSI. Many building codes and the ASME A112.19.2 fixture standard list maximum static water pressure as 80 PSI (552 kPa).

Royal® Flushometer

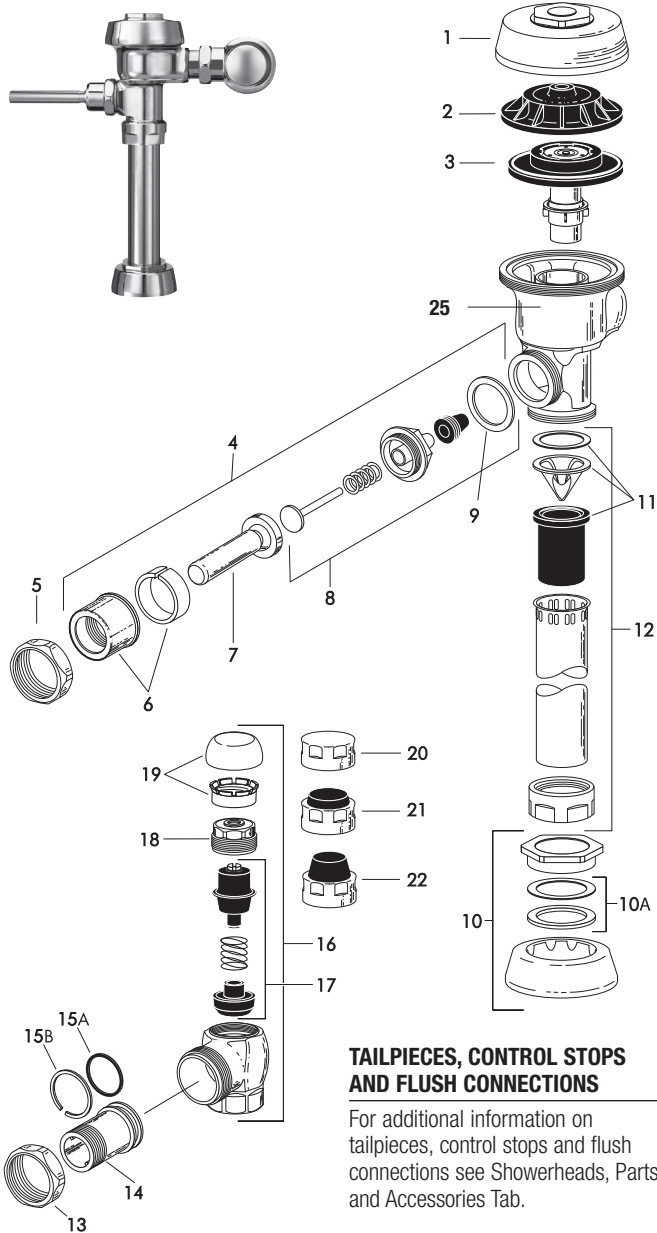

TAILPIECES, CONTROL STOPS AND FLUSH CONNECTIONS

For additional information on tailpieces, control stops and flush connections see Showerheads, Parts and Accessories Tab.

ITEM 10A. SLIP JOINT GASKETS AND RINGS

Size	Code No.	Part No.	Description
1-1/2"	5306058	F-3	Red Friction Ring
	5322001	VBF-5	Black Slip Joint Gasket
	5319086	S-30	Flexible Seat
1-1/2" x 1-1/4"	0319079	S-21	Rigid Seat (rubber over brass)
	0396062	F-105	Slip Joint Gasket – Rigid
1-1/4"	5306057	F-3	Red Friction Ring
	5322176	VBF-5	Black Slip Joint Gasket
	0307052/5307052	G-21	Rigid Seat (rubber over brass)
1"	5306056	F-3	Red Friction Ring
	5306115	F-5	Black Slip Joint Gasket
3/4"	5306055	F-3	Red Friction Ring
	5306113	F-5	Black Slip Joint Gasket

* See pages 102-103 for additional lengths

† For use with 1" and 3/4" H-700-A and 1" H-600-A Bak-Chek® screwdriver control stop

‡ For use with 3/4" H-600-A Bak-Chek® screwdriver control stop

RW for use with Reclaimed Water Flushometers

PARTS LIST

Item No.	Code No.	Part No.	Description
1.	0301172PK	A-72	CP Cover
	0301435PK	A-72-HE	CP High Efficiency Cover
2.	0301168	A-71	Inside Cover
	0301336	A-71-1	Inside Cover (Purple)
3.	—	—	Dual-Filtered Bypass Diaphragm Assembly (refer to table and diagram on following page)
4.	3302002	B-73-A	CP ADA-Compliant Triple Seal Handle Assembly
	0302267	B-73-A-PH	CP ADA-Compliant Triple Seal Handle Assembly
5.	0301082PK	A-6	CP Handle Coupling
6.	0302109	B-7-A	CP Socket Assembly
7.	0302389PK	B-74-A	CP ADA-Compliant Handle
8.	3302003	B-51-A	Triple Seal Handle Repair Kit
9.	5301139	A-31	Handle Gasket – 48 per package
10.	0306125	F-5-AW	3/4" (19 mm) CP Spud Coupling Assembly
	0306140	F-5-AU	1-1/4" (32 mm) CP Spud Coupling Assembly
	0306146	F-5-AT	1-1/2" (38 mm) CP Spud Coupling Assembly
10A.	SEE SLIP JOINT GASKETS AND RINGS TABLE BELOW LEFT		
11.	3323182	V-651-A	High Back Pressure Vacuum Breaker Repair Kit
12.	3393004	V-600-AA	3/4" (19 mm) x 9" (228 mm) CP Vacuum Breaker
	3393006	V-600-AA	1-1/4" (32 mm) x 9" (228 mm) CP Vacuum Breaker
	3393007	V-600-AA	1-1/2" (38 mm) x 9" (228 mm) CP Vacuum Breaker
13.	0308676	H-550	CP Stop Coupling
14.	0308801	H-551-A	CP Adjustable Tailpiece 2-1/16" (52 mm long) Standard Length*
15A.	5308696	H-553	O-ring – 24 per package
15B.	5308381	H-552	Locking Ring – 12 per package
16.	3308386	H-700-A	1" (25 mm) CP Bak-Chek® Screwdriver Stop
	0388141	H-700-A-RW	1" (25 mm) CP Bak-Chek® Screwdriver Stop
	3308384	H-700-A	3/4" (19 mm) CP Bak-Chek® Screwdriver Stop
	0388142	H-700-A-RW	3/4" (19 mm) CP Bak-Chek® Screwdriver Stop
17.	3308853	H-541-ASD	Control Stop Repair Kit †
	3308856	H-543-ASD	Control Stop Repair Kit ‡
18.	0308612PK	H-622	CP Bonnet †
	0308892	H-608-RW	PH Bonnet †
	0308843	H-577	CP Bonnet † – DISCONTINUED
19.	3308772	H-1010-A	Vandal Resistant Control Stop Cap Assembly †
	3308790	H-1009-A	Vandal Resistant Control Stop Cap Assembly † H-600 3/4" Stop only
20.	0308738PK	H-573	Control Stop Cap CP †
	0308848PK	H-582	Control Stop Cap CP †
21.	3308866	H-574	Control Stop Cap with Bumper † (-YO Variation)
	3308867	H-576	Control Stop Cap with Extended Bumper † (-YG Variation)
23.	3388015	H-1015	Flow Control Kit (not Shown) (HEU Only)
24.	3308735	H-634-AA-RW	1" (25 mm) Sweat Solder Kit w/ Cast Set Screw (Purple Flange not shown)
	3308736	H-636-AA-RW	3/4" (19 mm) Sweat Solder Kit w/ Cast Set Screw (Flange not shown)
3308785	H-636-AA	1" (25 mm) Sweat Solder Kit w/ Cast Set Screw (Purple Flange not shown)	
	3308788	H-636-AA	3/4" (19 mm) Sweat Solder Kit w/ Cast Set Screw (Flange not shown)
25.	0301043PK	A-3	CP Body no tail assembly (H-551-A)

Sloan products are also available in satin, brushed nickel, chrome, gold and polished brass finishes – contact factory for part numbers.

Royal® Flushometer

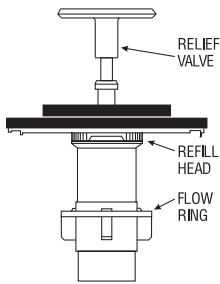
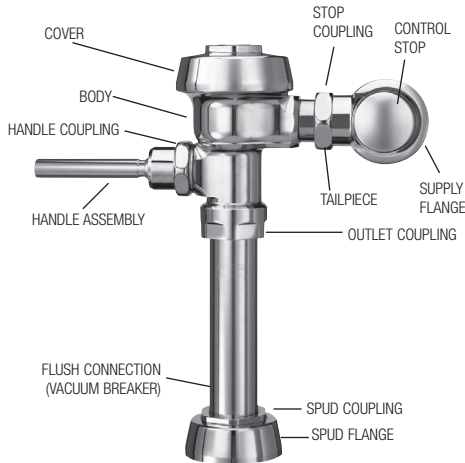

THE COLORS OF THE RELIEF VALVE AND THE REFILL HEAD PLUS THE SHAPE OF FLOW RING IDENTIFY THE FLUSH VOLUME OF A DUAL-FILTERED DIAPHRAGM ASSEMBLY.

DUAL-FILTERED DIAPHRAGM ASSEMBLY

Available in diaphragm only and Royal® Performance™ Kits.

Royal® Performance™ Kit includes dual-filtered diaphragm assembly (item 3), handle repair kit with triple seal packing (item 8), high back pressure vacuum breaker repair kit (item 11), and one tailpiece O-ring (item 15A). DIAPHRAGM ONLY KIT contains "drop-in" dual-filtered diaphragm assembly (item 3) ONLY.

The dual-filtered diaphragm can be used in Royal®, Regal®, and similar diaphragm-style valve bodies. For use in Sloan valve bodies with a bell-shaped cover (manufactured before 1964), replace the bottom filter ring in these kits with a blue A-108 filter ring (not shown Sloan Code No. **5301283**).

NOTE: In January 1998, the Royal® diaphragm design was upgraded to a preassembled unit with two (2) plastic filtering rings attached to the rubber diaphragm (one on top and one on bottom). If the flushometer you are servicing has our older, segmented diaphragm with brass by-pass hole, refer to our Regal section for additional troubleshooting information.

ROYAL® PERFORMANCE KIT

Code No.	Part No.	Description	Relief Valve†	Refill Head*	Flow Ring
3301070	A-1101-A	Low Consumption Water Closets-1.6 gpf (6.0 Lpf)**	Green	Gray	Smooth
3301071	A-1102-A	Water Saver Water Closets-3.5 gpf (13.2 Lpf)**	White	Gray	Smooth
3301072	A-1103-A	9 Liter European Water Closets-2.4 gpf (9.0 Lpf)	Blue	Gray	Smooth
3301073	A-1106-A	Wash Down Urinals-0.5 gpf (1.9 Lpf)	Green	Black	Smooth
3301074	A-1107-A	Low Consumption Urinals-1.0 gpf (3.8 Lpf)**	Green	Black	Slotted
3301075	A-1108-A	Water Saver Urinals-1.5 gpf (5.7 Lpf)**	Black	Black	Smooth

*CLOSET REFILL HEADS (GRAY) HAVE LARGER SLOTS THAN URINAL REFILL HEADS (BLACK).

DIAPHRAGM ONLY KIT

Code No.	Part No.	Description	Relief Valve†	Refill Head*	Flow Ring
3301118	A-1048-A-BX	Low Consumption Water Closets-1.1 gpf (4.2 Lpf)**	Blue	Black	Smooth
3301502	A-1041-A	Low Consumption Water Closets-1.6 gpf (6.0 Lpf)**	Green	Gray	Smooth
3301501	A-1038-A	Water Saver Water Closets-3.5 gpf (13.2 Lpf)**	White	Gray	Smooth
3301505	A-1044-A	9 Liter European Water Closets-2.4 gpf (9.0 Lpf)	Blue	Gray	Smooth
3301504	A-1043-A	Wash Down Urinals-0.5 gpf (1.9 Lpf)	Green	Black	Smooth
3301503	A-1042-A	Low Consumption Urinals-1.0 gpf (3.8 Lpf)**	Green	Black	Slotted
3301500	A-1037-A	Water Saver Urinals-1.5 gpf (5.7 Lpf)**	Black	Black	Smooth
3301506	A-1045-A	High-Efficiency Water Closets-1.28 gpf (4.8 Lpf)	Blue	Gray	Smooth
3301142	A-1047-A	High-Efficiency Urinals-0.25 gpf (1.0 Lpf) with White Inserts	White	HEU Black	Smooth
3301143	A-1050-A	High-Efficiency Urinals-0.125 gpf (0.5 Lpf) with White Inserts	Blue	HEU Black	Smooth
3301594	A-1075-A-BX	High-Efficiency Water Closets-1.28 gpf (4.8 Lpf) RW	Blue	Black	Smooth
3301592	A-1073-A-BX	High-Efficiency Urinals-0.5 gpf (1.9 Lpf) RW	Green	Black	Smooth + Slotted
3301591	A-1077-A-BX	High-Efficiency Urinals-0.25 gpf (1.0 Lpf) RW	White	HEU Black	Smooth
3301590	A-1070-A-BX	High-Efficiency Urinals-0.125 gpf (0.5 Lpf) RW	Blue	HEU Black	Smooth

† Consult factory for availability of replacement plastic relief valves (green, black, blue, and white) and brass relief valves.

NOTE: For older water closets that require 4.5 gpf (17.0 Lpf), choose kits A-1102-A or A-1038-A, but remove the flow ring before use. For blowout-style urinals that require 3.5 gpf (13.2 Lpf), choose kits A-1102-A or A-1038-A. For service sinks that require 6.5 gpf (24.6 Lpf), order A-36-A diaphragm repair kit (not shown Sloan Code No. **3301036**) and remove the flow ring before use. Regulations for low consumption fixtures prohibit the use of higher flush volumes.

*CLOSET REFILL HEADS (GRAY) HAVE LARGER SLOTS THAN URINAL REFILL HEADS (BLACK).

** WATER SAVER (3.5 GPF CLOSET AND 1.5 GPF URINAL) AND LOW CONSUMPTION (1.6 GPF CLOSET AND 1.0 GPF URINAL) FIXTURES MUST USE MATCHING GPF (LPF) DIAPHRAGM KITS; USING A SMALLER GPF (LPF) KIT IN FIXTURES NOT INTENDED FOR LESS VOLUME WILL RESULT IN INADEQUATE DILUTION IN URINALS AND IMPROPER EVACUATION IN CLOSETS.

RW for use with Reclaimed Water Flushometers.

ROYAL® TUNE UP KIT

Code No.	Part No.	Description
3301184	A1121-A	Tune-up Kit (1.6 gpf/6.0 Lpf) Closet
3301185	A1122-A	Tune-up Kit (3.5 gpf/13.2 Lpf) Closet
3301187	A1125-A	Tune-up Kit (1.28 gpf/4.8 Lpf) Closet
3301188	A1126-A	Tune-up Kit (0.125 gpf/0.5 Lpf) Urinal
3301189	A1127-A	Tune-up Kit (1.0 gpf/3.8 Lpf) Urinal
3301190	A1128-A	Tune-up Kit (1.5 gpf/5.7 Lpf) Urinal
3301191	A1129-A	Tune-up Kit (0.25 gpf/1.0 Lpf) Urinal

Includes Dual-Filtered Diaphragm Assembly, B-51-A Handle Repair Kit, H-553 O'ring, V-651-A High Back Pressure Vacuum Breaker Repair Kit, A-71 Inside Plastic Cover.

Royal® Flushometer

TROUBLESHOOTING GUIDE

ATTENTION INSTALLERS: With the exception of the control stop inlet, **DO NOT USE** pipe sealant or plumbing grease on any valve component or coupling! To protect the chrome or special finish of Sloan flushometers, **DO NOT USE** toothed tools to install or service these valves. Use our A-50 Super-Wrench or other smooth-jawed wrench to secure couplings. Regulations for low consumption fixtures (1.6 gpf/6.0 Lpf closets and 1.0 gpf/3.8 Lpf urinals) prohibit use of higher flush volumes.

1. Flushometer does not function (no flush).

- Control stop or main supply valve is closed. Open control stop or main supply valve.
- Handle assembly is damaged. Replace B-73-A handle or repair with B-51-A handle repair kit.
- Relief valve is damaged. Replace relief valve.

2. Handle leaks.

- Handle seal or handle assembly is damaged. Replace B-73-A handle or repair with B-51-A handle repair kit.

3. Water splashes from fixture.

- Control stop is open wider than necessary. Adjust control stop for desired delivery of water volume.
- Water saver/conventional diaphragm assembly is installed on low consumption fixture or closet diaphragm assembly is installed on urinal fixture. Determine the required flush volume (see label on valve or markings on fixture). Replace diaphragm assembly or relief valve for appropriate flush volume of fixture.

4. Volume of water is insufficient to adequately siphon fixture.

- Control stop is not open wide enough. Adjust control stop for desired delivery of water volume.
- Diaphragm assembly is damaged. Replace diaphragm assembly.
- Low consumption diaphragm assembly is installed on water saver/conventional fixture or urinal diaphragm assembly is installed on closet fixture. Determine the required flush volume (see label on valve or markings on fixture). Replace diaphragm assembly or relief valve for appropriate flush volume of fixture.
- Inadequate water volume or pressure is available from supply. Increase flow rate or pressure to the valve. If gauges are not available to measure supply pressure/volume, remove relief valve from diaphragm assembly and open the control stop.

If the fixture siphons: Additional water volume is required. Install higher flushing volume relief valve or diaphragm assembly or cut flow ring from guide. **IMPORTANT: LAWS AND REGULATIONS PROHIBIT THE USE OF HIGHER FLUSHING VOLUMES THAN LISTED ON FIXTURE OR FLUSHOMETER.**

If the fixture **DOES NOT** siphon (or a low consumption flush is required): Additional steps must be taken to increase the water pressure and/or volume at the water supply. Contact fixture manufacturer for minimum supply requirements of fixture.

5. Flushometer valve closes immediately (short flush).

- Worn or damaged diaphragm assembly. Replace diaphragm assembly.
- Handle assembly is damaged. Replace B-73-A handle or repair with B-51-A handle repair kit.
- Low consumption diaphragm assembly is installed on water saver/conventional fixture or urinal diaphragm assembly is installed on closet fixture. Determine the required flush volume (see label on valve or markings on fixture). Replace relief valve or diaphragm assembly for appropriate flush volume of fixture.

6. Length of flush is too long (long flush) or fails to shut off.

- Bypass hole (upper filter ring) of diaphragm assembly is dirty. Remove the diaphragm assembly. Disassemble the filter rings from the diaphragm, wash under running water, and reassemble. Replace as necessary.

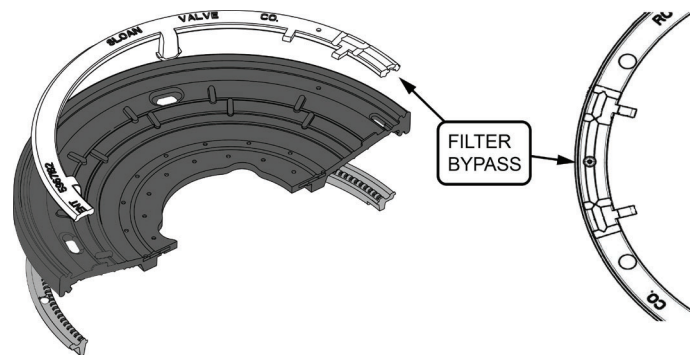

- Relief valve or diaphragm assembly is damaged. Replace relief valve or diaphragm assembly.
- Water saver/conventional diaphragm assembly is installed on low consumption fixture or closet diaphragm assembly is installed on urinal fixture. Determine the required flush volume (see label on valve or markings on fixture). Replace diaphragm assembly or relief valve for appropriate flush volume of fixture.
- Inside cover is damaged. Install new A-71 part.
- Line water pressure dropped and is insufficient to close valve. Close the control stop until pressure is restored.
- Relief valve is not seated properly. Disassemble diaphragm components (relief valve, filter rings, and diaphragm unit), wash under running water, and reassemble. Replace as necessary.

7. Chattering noise is heard during flush.

- Inside cover is damaged. Install new A-71 part.
- Relief valve or diaphragm assembly is damaged. Replace relief valve or diaphragm assembly.

CARE AND CLEANING INSTRUCTIONS

DO NOT USE abrasive or chemical cleaners to clean flushometers that may dull the luster and attack the chrome or decorative finish. Use **ONLY** mild soap and water, then wipe dry with a clean towel or cloth. When cleaning the bathroom tile, protect the flushometer from any splattering of cleaner. Acids and cleaning fluids can discolor or remove chrome plating.

**When assistance is required, please contact
Sloan Technical Support at: 1-888-SLOAN-14 (1-888-756-2614).**

Royal II® Flushometer

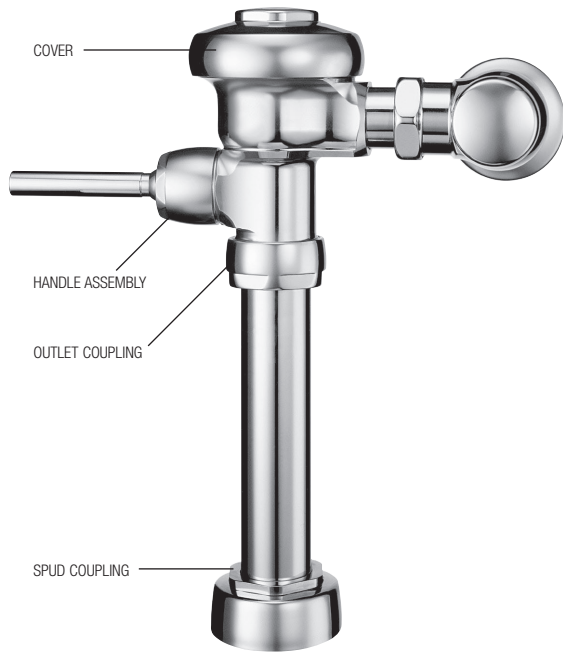

The Royal II® flushometer offers everything the Royal® has – and more. **PLEASE REFER TO THE ROYAL® SECTION** for all maintenance issues on the Royal II, with the exceptions noted in the chart below.

Royal II®'s new handle is a one-piece design for smoother lines. Its aesthetic cover accentuates the Royal II®'s new design, and the new vacuum breaker couplings and flange add the finishing touches.

PARTS LIST

Code No.	Part No.	Description
0301298PK	A-206	Royal II® Cover
0302375	B-95-A	Royal II® Handle Assembly
0306145	F-56-A	Royal II® Spud Coupling Assembly 1-1/2" CP
0306128	F-57-A	Royal II® Spud Coupling Assembly 3/4" CP
0306127	F-58-A	Royal II® Spud Coupling Assembly 1-1/4" CP
0323369PK	V-572	Royal II® Coupling CP

**AVAILABLE AS A COMPLETE ASSEMBLY.
REPAIR PARTS REMAIN AVAILABLE
FOR A LIMITED TIME.**

Continental® Flushometer



The Continental® flushometer is part of the Sloan flushometer designer series, and offers proven Royal® performance – and more. **PLEASE REFER TO THE ROYAL® SECTION** for all maintenance issues on the Continental®, with the exceptions noted in the chart below.

Continental®'s sleek styling make it ideal for many applications.

PARTS LIST

Code No.	Part No.	Description
0301077PK	A-4	Continental® Cover
0301221	A-71	Continental® Inside Cover

SLIP JOINT GASKETS AND RINGS

For additional information on Slip Joint Gaskets and Rings see Item 10A table at bottom of page 15.

**AVAILABLE AS A COMPLETE ASSEMBLY.
REPAIR PARTS REMAIN AVAILABLE
FOR A LIMITED TIME.**

* Limited complete assemblies still available.

UPPERCUT® Dual-flush Flushometer

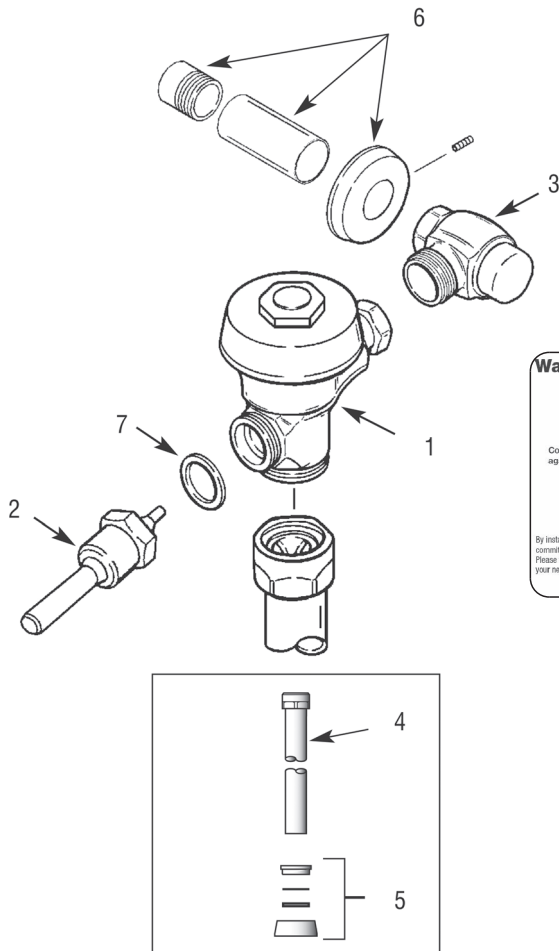

PARTS LIST

Item No.	Code No.	Part No.	Description
1.	—	†	Valve Assembly
2.	3372003	WES-212	ADA Compliant Dual-Flush Handle
	3372010	WES-212	ADA Compliant Dual-Flush Handle (Spanish)
3.	3308386	H-700-A	Bak-Chek® Control Stop
4.	3393007	V-600-AA	1-1/2" (38 mm) x 9" (229 mm) Vacuum Breaker Assembly ‡
5.	0306146	F-5-AT	1-1/2" (38 mm) Spud Coupling Assembly
6.	3308782	H-633-AA	1" (25 mm) CP Sweat Solder Kit with Cast Set Screw Flange
7.	5301139	A-31	Handle Gasket – 48 per package
8.	0372006	WES-13	Wall Plate (English)
	0372019	WES-18	Wall Plate (Spanish)

† Part number varies with valve model variation; consult factory.

‡ Length varies with valve model variation; consult factory.

Not shown: A-1041-A (**3301502**)

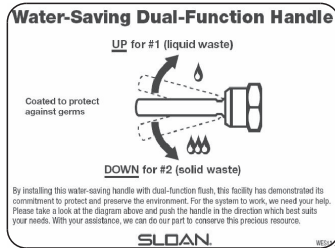

Sloan® Flushometer

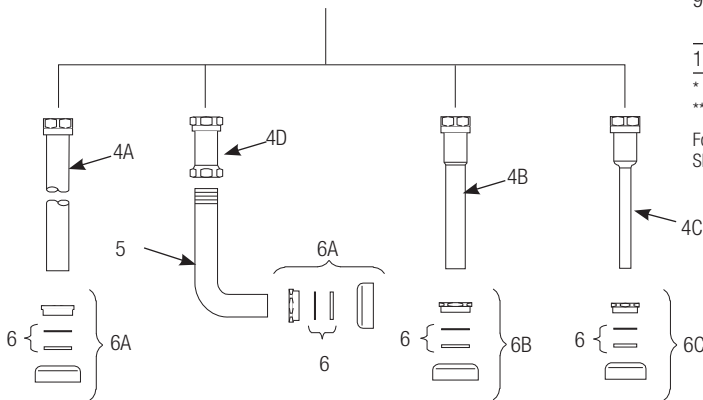
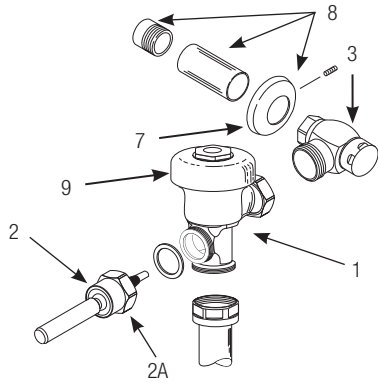

PARTS LIST

Item No.	Code No.	Part No.	Description
1.	—	A-3-A	Valve Assembly – contact Tech Support for proper assembly
2.	3302002	B-73-A	ADA Compliant Handle Assembly
2A.	0301082PK	A-6	CP Handle Coupling
3.	—	H-710-A	Bak-Chek® Control Stop – 3/4" or 1"
4A.	5323007	V-500-AA	1-1/2" (38 mm) x 9" (229 mm) Vacuum Breaker Assembly ** – 6 per package
4B.	5323006	V-500-AA	1-1/4" (32 mm) x 9" (229 mm) Vacuum Breaker Assembly – 6 per package
4C.	5323005	V-500-AA	3/4" (19 mm) x 9" (229 mm) Vacuum Breaker Assembly – 6 per package
4D.	5323010	V-500-A	Short Vacuum Breaker Assembly (6 per pack)
5.	0396293PK	F-109	1-1/2" (38 mm) Elbow Flush Connection
6.	SEE SLIP JOINT GASKETS AND RINGS TABLE BELOW		
6A.	0306145	F-56-A	1-1/2" (38 mm) Spud Coupling Assembly
6B.	0306142	F-55-A	1-1/4" (32 mm) Spud Coupling Assembly
6C.	0306102	F-54-A	3/4" (19 mm) Spud Coupling Assembly
7.—	F-7		Supply Flange (Supplied when Valve is not ordered with Sweat Solder Kit)
8.	3308782	H-633-AA	1" (25 mm) Sweat Solder Kit with Cast Set Screw Flange
	3308788	H-636-AA	3/4" (19 mm) Sweat Solder Kit with Cast Set Screw Flange
9.	0378000PK	SV-10	CP Sloo Cover
	0378003PK	SV-10-HE	CP High Efficiency Sloo Cover
10.	3388015	H-1015	Flow Control Kit (not Shown)(HEU Only)

* Part number varies with valve model variation; consult factory.

** Length varies with valve model variation; consult factory.

For optimum water conservation and flushometer performance, use only Genuine Sloan Parts.

ITEM 6. SLIP JOINT GASKETS AND RINGS

Size	Code No.	Part No.	Description
1-1/2"	5306058	F-3	Red Friction Ring
	5322001	VBF-5	Black Slip Joint Gasket
	5319086	S-30	Flexible Seat
	0319079	S-21	Rigid Seat (rubber over brass)
1-1/2" x 1-1/4"	0396062	F-105	Slip Joint Gasket – Rigid
1-1/4"	5306057	F-3	Red Friction Ring
	5322176	VBF-5	Black Slip Joint Gasket
	0307052/5307052	G-21	Rigid Seat (rubber over brass)
1"	5306056	F-3	Red Friction Ring
	5306115	F-5	Black Slip Joint Gasket
3/4"	5306055	F-3	Red Friction Ring
	5306113	F-5	Black Slip Joint Gasket

Sloan® Flushometer

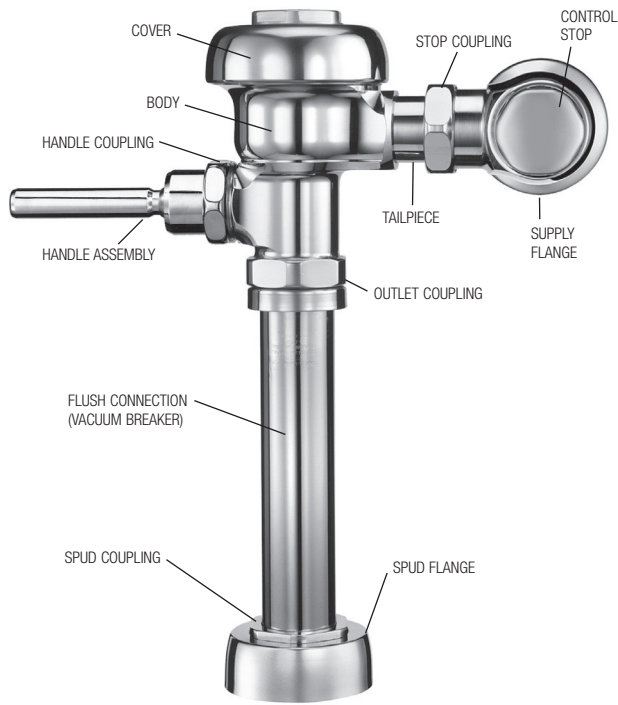

DIAPHRAGM INSIDE PARTS KITS (SEE ILLUSTRATION BELOW)

Refer to Parts List. Includes Relief Valve and Diaphragm Assembly

Item No.	Code No.	Part No.	Application
A.	3378041	SV-41-A	1.6 gpf/6.0 Lpf - Closet
B.	3378038	SV-38-A	3.5 gpf/13.2 Lpf - Closet
C.	3378044	SV-44-A	2.4 gpf/9.0 Lpf - Closet
D.	3378037	SV-37-A	1.5 gpf/5.7 Lpf - Urinal
E.	3378042	SV-42-A	1.0 gpf/3.8 Lpf - Urinal
F.	3378043	SV-43-A	0.5 gpf/1.9 Lpf - Urinal
G.	3378047	SV-47-A	1.28 gpf/4.8 Lpf - Closet

INSIDE COMPONENTS

Item No.	Code No.	Part No.	Description
1a.	5301211	A-19-ALC	Relief Valve, Green (Closet/Urinal-LC) – 12 per package
1b.	5301058	A-19-AC	Relief Valve, White (Closet) – 12 per package
1c.	0301143	A-19-AL	Relief Valve, Blue (9 Liter Closet)
1d.	5301059	A-19-AU	Relief Valve, Black (Urinal) – 12 per package

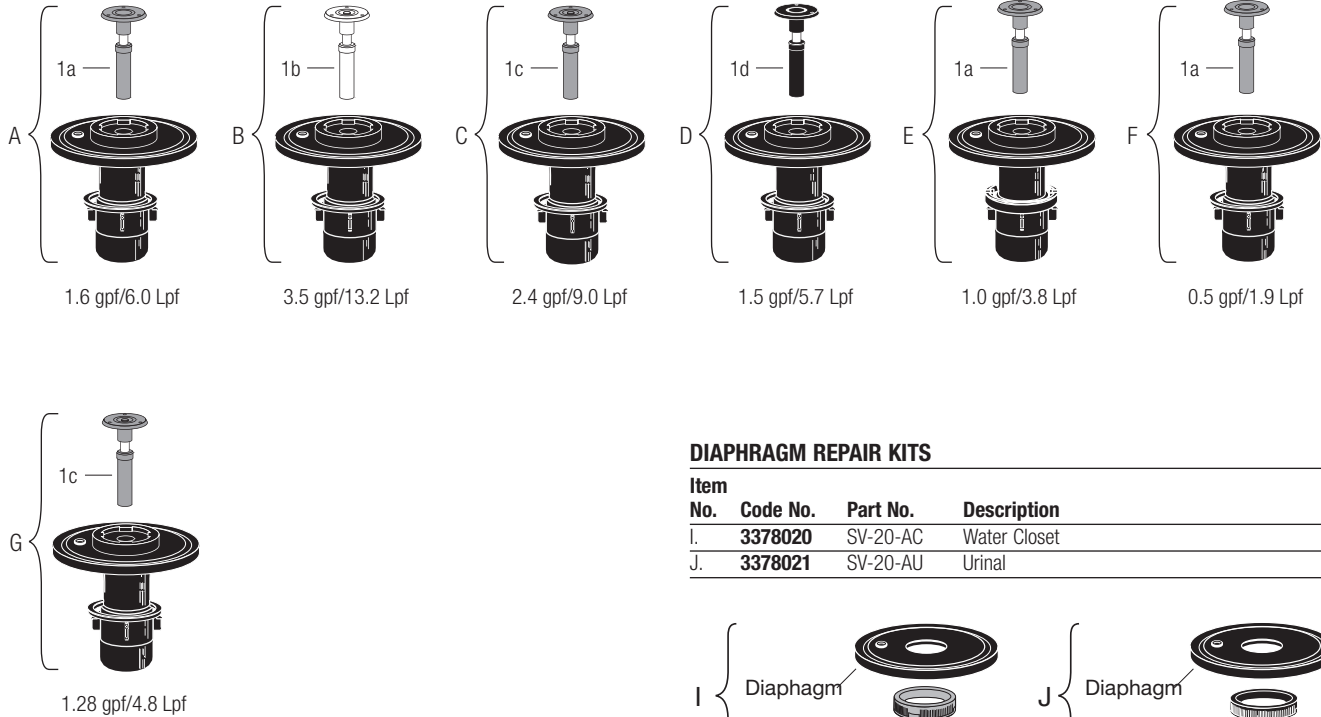

DIAPHRAGM REPAIR KITS

Item No.	Code No.	Part No.	Description
I.	3378020	SV-20-AC	Water Closet
J.	3378021	SV-20-AU	Urinal

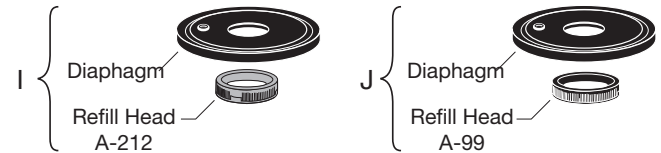

Sloan® Flushometer

TROUBLESHOOTING GUIDE

ATTENTION INSTALLERS: With the exception of the control stop inlet, **DO NOT USE** pipe sealant or plumbing grease on any valve component or coupling! To protect the chrome or special finish of Sloan flushometers, **DO NOT USE** toothed tools to install or service these valves. Use our A-50 Super-Wrench or other smooth-jawed wrench to secure couplings. Regulations for low consumption fixtures (1.6 gpf/6.0 Lpf closets and 1.0 gpf/3.8 Lpf urinals) prohibit use of higher flush volumes.

1. Flushometer DOES NOT function (no flush).

- A. Control stop or main valve is closed. Open control stop or main valve.
- B. Handle assembly is worn. Install handle repair kit or replace handle assembly.
- C. Relief valve is worn. Replace inside parts kit.

2. Insufficient volume of water to adequately siphon fixture.

- A. Control stop not open enough. Adjust control stop for desired delivery of water volume.
- B. Urinal flushometer Parts inside a Closet flushometer. Replace inside urinal parts with proper closet flushometer parts.
- C. Low consumption flushometer installed on a non-low consumption fixture. Replace inside parts kit with water saver kit.
- D. Water saver kit installed in old, non-water saver bowl. Position refill head so that SIDE 1 is in the UP position.
- E. Water supply volume or pressure is inadequate. If no gauges are available to properly measure supply pressure or volume of water at the flushometer, then remove the relief valve from the inside parts kit, reassemble the flushometer and completely open the control stop.
 - If the fixture siphons, more water volume is required. If a 3.5 gpf inside parts kit is installed in the flushometer, then first flip the refill head (under the diaphragm) to obtain a 4.5 gpf volume. If this volume is still inadequate, remove the flow ring from the guide to obtain a 6.5 gpf kit. If additional flow is still required, try a low pressure guide kit. **IMPORTANT: LAWS AND REGULATIONS PROHIBIT THE USE OF HIGHER FLUSHING VOLUMES THAN LISTED ON FIXTURE OR FLUSHOMETER.**
 - If fixture does not siphon or if a Low Consumption fixture is installed, or if the above steps do not prove satisfactory, steps must be taken to increase the water supply pressure and/or volume. Contact the fixture manufacturer for minimum water supply requirements of the fixture.

3. Flushometer closes off immediately.

- A. Ruptured or damaged diaphragm. Replace inside parts kit.
- B. Enlarged bypass orifice from corrosion or damage. Replace inside parts kit.

4. Length of flush is too short (short flushing).

- A. Diaphragm assembly and guide assembly are not hand-tight. Screw the two assemblies hand-tight.
- B. Enlarged bypass orifice from corrosion or damage. Replace inside parts kit.
- C. Urinal flushometer parts inside a closet flushometer. Replace inside urinal parts with proper closet flushometer parts.
- D. Low consumption flushometer installed on a higher consumption fixture. Replace inside parts kit with water saver kit.
- E. Handle assembly is damaged. Replace handle.

5. Length of flush is too long (long flushing) or continuous.

- A. Relief valve is not seating properly or bypass orifice is clogged because of foreign material, or bypass orifice is closed by an invisible gelatinous film from "over-treated" water. Disassemble the working parts and wash thoroughly.

NOTE: SIZE OF ORIFICE IN THE BY-PASS IS EXTREMELY IMPORTANT FOR PROPER METERING OF WATER INTO THE UPPER CHAMBER OF THE FLUSHOMETER. DO NOT ENLARGE OR DAMAGE THIS ORIFICE. REPLACE INSIDE KIT IF CLEANING DOES NOT CORRECT PROBLEM.

- B. Supply line water pressure has dropped and is not sufficient to close the valve. Close control stop until pressure has been restored.
- C. Closet flushometer parts inside an urinal flushometer. Replace Inside closet parts with proper urinal flushometer parts.
- D. Inside cover is damaged. Replace inside cover.

6. Chattering noise is heard during flush.

- A. The segment diaphragm is installed upside-down. Replace the segment diaphragm to the proper position as instructed by markings on the diaphragm.
- B. Inside cover is damaged. Replace inside cover.

7. Handle Leaks.

- A. Handle gasket, seal or assembly is damaged. Replace as required.

CARE AND CLEANING INSTRUCTIONS

DO NOT USE abrasive or chemical cleaners (including chlorine bleach) to clean flushometers that may dull the luster and attack the chrome or special decorative finishes. Use **ONLY** mild soap and water, then wipe dry with a clean towel or cloth.

While cleaning the bathroom tile, protect the flushometer from any splattering of cleaner. Acids and cleaning fluids will discolor or remove chrome plating.

When assistance is required, please contact

Sloan Technical Support at: 1-888-SLOAN-14 (1-888-756-2614).

Regal® Flushometer

NOTE: Also for use with Regal® XL
(Since mid-2010)



The repair kits and parts listed on this page are designed to service all Sloan diaphragm type flushometers, including those manufactured for low consumption (LC) usage.

ABBREVIATIONS:
 CP = Chrome plated
 gpf = gallons per flush
 Lpf = Liters per flush
 LC = Low consumption
 pkg = package

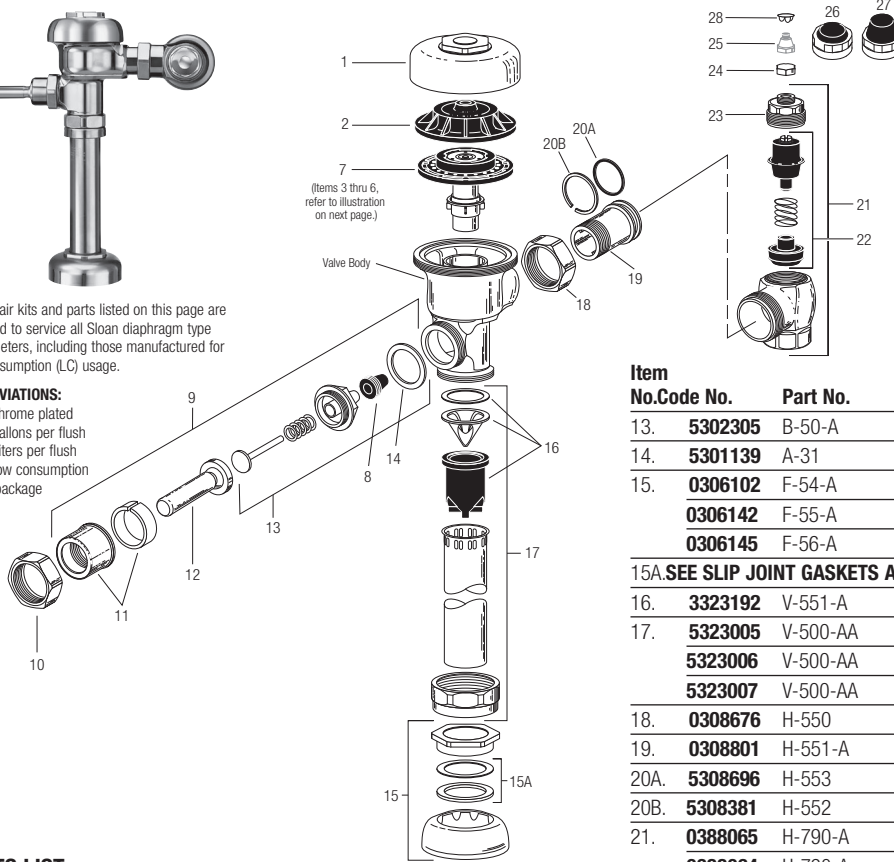

TAILPIECES, CONTROL STOPS AND FLUSH CONNECTIONS

For additional information on tailpieces, control stops and flush connections see Showerheads, Parts and Accessories Tab.

PARTS LIST

Item No.	Code No.	Part No.	Description
1.	0317004PK	R-10	CP Cover
	—	R-10-HE	CP High Efficiency Cover
2.	0301168	A-71	Inside Cover
SEE ITEMS 3A THROUGH 6E IN CHART ON NEXT PAGE			
3A.	5301058	A-19-AC	Relief Valve, White (Closet) – 12 per package
3B.	5301059	A-19-AU	Relief Valve, Black (Urinal) – 12 per package
3C.	5301211	A-19-ALC	Relief Valve, Green (Closet/Urinal-LC) – 12 per package
3D.	0301143	A-19-AL	Relief Valve, Blue (9 Liter Closet)
4.	5301111	A-15-A	Disc – for all Inside Parts Kits – 12 per package
5.	5301188	A-156-A	Diaphragm – for all Inside Parts Kits – 12 per package
6A.	5301236	A-163-A	Guide Assembly 4.5 gpf/17.0 Lpf Closet & 1.5 gpf/5.7 Lpf Urinal – 12 per package
6B.	5301032	A-152-A	Guide Assembly 3.5 gpf/13.2 Lpf Closet – 12 per package
6C.	5301031	A-151-A	Guide Assembly 1.6 gpf/6.0 Lpf LC Closet – 12 per package
6D.	5301155	A-155-A	Guide Assembly 1.0 gpf/3.8 Lpf LC Urinal – 12 per package
6E.	5301157	A-157-A	Guide Assembly 0.5 gpf/1.9 Lpf Urinal – 12 per package
7.	SEE INSIDE PARTS KITS CHART ON NEXT PAGE		
8.	5302297	B-39	Seal – 12 per package
9.	5302279	B-32-A	CP Handle Assembly – 6 per package
	3302002	B-73-A	CP Handicap Handle Assembly (ADA Compliant)
10.	0301082PK	A-6	CP Handle Coupling
11.	0302109	B-7-A	CP Socket Assembly
12.	5302274	B-32	CP Handle Grip – 12 per package
	0302389PK	B-74-A	CP Handicap Handle Grip (ADA Compliant)

Item

No.	Code No.	Part No.	Description
13.	5302305	B-50-A	Handle Repair Kit – 6 per package
14.	5301139	A-31	Handle Gasket – 48 per package
15.	0306102	F-54-A	3/4" CP Spud Coupling Assembly
	0306142	F-55-A	1-1/4" CP Spud Coupling Assembly
	0306145	F-56-A	1-1/2" CP Spud Coupling Assembly
15A. SEE SLIP JOINT GASKETS AND RINGS TABLE BELOW			
16.	3323192	V-551-A	Vacuum Breaker Repair Kit
17.	5323005	V-500-AA	3/4" x 9" CP Vacuum Breaker – 6 per package
	5323006	V-500-AA	1-1/4" x 9" CP Vacuum Breaker – 6 per package
	5323007	V-500-AA	1-1/2" x 9" CP Vacuum Breaker – 6 per package
18.	0308676	H-550	CP Stop Coupling †
19.	0308801	H-551-A	CP Adjustable Tailpiece 2-1/16" long †
20A.	5308696	H-553	O-ring – 24 per package
20B.	5308381	H-552	Locking ring – 12 per package
21.	0388065	H-790-A	1" Screwdriver Bak-Chek® Stop CP – complete
	0388064	H-790-A	3/4" Screwdriver Bak-Chek® Stop CP – complete
	0388029	H-740-A	1" Screwdriver Bak-Chek® Stop CP – DISCONTINUED
	0388031	H-740-A	3/4" Screwdriver Bak-Chek® Stop CP – DISCONTINUED
22.	3308853	H-541-ASD	1" Control Stop Repair Kit *
	3308856	H-543-ASD	3/4" Control Stop Repair Kit **
23.	0308612PK	H-622	CP Bonnet (Current Regal)
	0308991	H-639	CP Bonnet – Pre 2010 Regal Stops* DISCONTINUED
	0308601	H-538	CP Bonnet ** – DISCONTINUED
24.	5388001	H-1012-A	CP Cap – 6 per package VP
25.	5310034	J-2/J-7	Bumper Assembly – 6 per package – DISCONTINUED
26.	3308866	H-574	Stop Cap, chrome plated with Seat Bumper (-YO)
27.	3308867	H-576	Stop Cap, chrome plated with Extended Seat Bumper (-YG)
28.	5388002	H-528	Hole Plug
29.	3388015	H-1015	Flow Control Kit (HEU Only) (not Shown)

† See pages 100-101 for additional lengths

*For use with 1" and 3/4" H-740-A CP (less cap) and 1" – H-540-A CP (with H-37 cap) Bak-Chek® screwdriver control stops

**For use with 3/4" H-740-A CP Bak-Chek® screwdriver control stops

ITEM 15A. SLIP JOINT GASKETS AND RINGS

Size	Code No.	Part No.	Description
1-1/2"	5306058	F-3	Red Friction Ring
	5322001	VBF-5	Black Slip Joint Gasket
	5319086	S-30	Flexible Seat
	0319079	S-21	Rigid Seat (rubber over brass)
1-1/2" x 1-1/4"	0396062	F-105	Slip Joint Gasket – Rigid
1-1/4"	5306057	F-3	Red Friction Ring
	5322176	VBF-5	Black Slip Joint Gasket
	0307052/5307052	G-21	Rigid Seat (rubber over brass)
1"	5306056	F-3	Red Friction Ring
	5306115	F-5	Black Slip Joint Gasket
3/4"	5306055	F-3	Red Friction Ring
	5306113	F-5	Black Slip Joint Gasket

Regal® Flushometer

NOTE: Also for use with Regal® XL
(Since mid-2010)

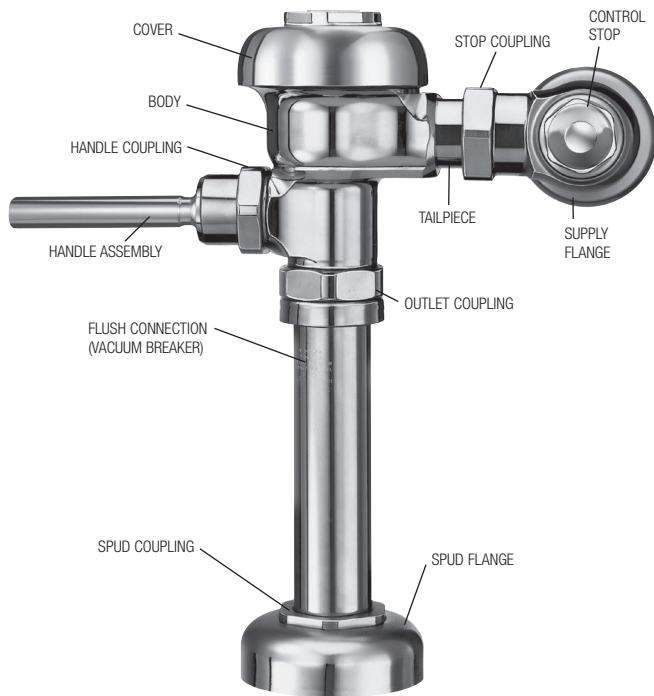

REGAL TUNE UP KIT

Code No.	Part No.	Description
3317027	R1121-A	Tune-up Kit (1.6 gpf/6.0 Lpf) Closet
3317026	R1122-A	Tune-up Kit (3.5 gpf/13.2 Lpf) Closet
3317028	R1124-A	Tune-up Kit (1.28 gpf/4.8 Lpf) Closet
3317031	R1126-A	Tune-up Kit (0.5 gpf/1.9 Lpf) Urinal
3317030	R1127-A	Tune-up Kit (1.0 gpf/3.8 Lpf) Urinal
3317029	R1128-A	Tune-up Kit (1.5 gpf/5.7 Lpf) Urinal

Includes Diaphragm Assembly, B-50-A Handle Repair Kit, H-553 O'ring, V-551-A Vacuum Breaker Repair Kit, A-71 Inside Plastic Cover.

MASTER FLUSHOMETER REBUILDING KITS (SEE PARTS LIST – ON PREVIOUS PAGE)

Refer to Parts List. Includes Items 7, 13, 16 & 20

Code No.	Part No.	Description
3317001	R-1001-A	Rebuild Kit (4.5 gpf/17.0 Lpf) Closet/Service Sink
3317002	R-1002-A	Rebuild Kit (1.5 gpf/5.7 Lpf) Urinal
3317003	R-1003-A	Rebuild Kit (3.5 gpf/13.2 Lpf) Closet
3317004	R-1004-A	Rebuild Kit (1.6 gpf/6.0 Lpf) Closet
3317005	R-1005-A	Rebuild Kit (1.0 gpf/3.8 Lpf) LC Urinal
3317011	R-1011-A	Rebuild Kit (0.5 gpf/1.9 Lpf) Urinal
3317012	R-1012-A	Rebuild Kit (2.4 gpf/9.0 Lpf) Closet
3301143	A-1050-A	DPB Rebuild Kit (0.125 gpf/0.5 Lpf) Urinal

REPAIR KIT WASHER SET (SEE PARTS LIST – ON PREVIOUS PAGE)

5301189	A-156-AA	Repair Kit Washer Set – Includes: 4, 5, 8 & 14
---------	----------	--

ITEM 7. INSIDE PARTS KITS (SEE ILLUSTRATIONS BELOW)

Item No.	Code No.	Part No.	Application
A.	3301036	A-36-A	4.5 gpf/17.0 Lpf - Closet
B.	3301037	A-37-A	1.5 gpf/5.7 Lpf - Urinal
C.	3301038	A-38-A	3.5 gpf/13.2 Lpf - Closet
D.	3301041	A-41-A	1.6 gpf/6.0 Lpf - Closet
E.	3301044	A-42-A	1.0 gpf/3.8 Lpf - Urinal
F.	3301081	A-43-A	0.5 gpf/1.9 Lpf - Urinal
G.	3301024	A-44-A	2.4 gpf/9.0 Lpf - Closet
H.	3301045	A-140-A	1.28 gpf/4.8 Lpf - Closet

ITEM 7. INSIDE PARTS COMPONENTS (SEE ILLUSTRATIONS BELOW)

Item No.	Code No.	Part No.	Description
3A.	5301058	A-19-AC	Relief Valve, White (Closet) – 12 per pkg.
3B.	5301059	A-19-AU	Relief Valve, Black (Urinal) – 12 per pkg.
3C.	5301211	A-19-ALC	Relief Valve, Green (Closet/Urinal-LC) – 12 per pkg.
3D.	0301143	A-19-AL	Relief Valve, Blue (9 Liter Closet)
4.	5301111	A-15-A	Disc – for all Inside Parts Kits – 12 per pkg.
5.	5301188	A-156-A	Diaphragm – for all Inside Parts Kits –12 per pkg.
5A.	5301176	A-56-A	Diaphragm – for all Inside Parts Kits – 6 per pkg.
6A.	5301236	A-163-A	Guide Assembly 4.5 gpf/17.0 Lpf Closet & 1.5 gpf/5.7 Lpf Urinal –12 per package
6B.	5301032	A-152-A	Guide Assembly 3.5 gpf/13.2 Lpf Closet – 12 per package
6C.	5301031	A-151-A	Guide Assembly 1.6 gpf/6.0 Lpf LC Closet – 12 per package
6D.	5301155	A-155-A	Guide Assembly 1.0 gpf/3.8 Lpf LC Urinal – 12 per package
6E.	5301157	A-157-A	Guide Assembly 0.5 gpf/1.9 Lpf Urinal – 12 per package

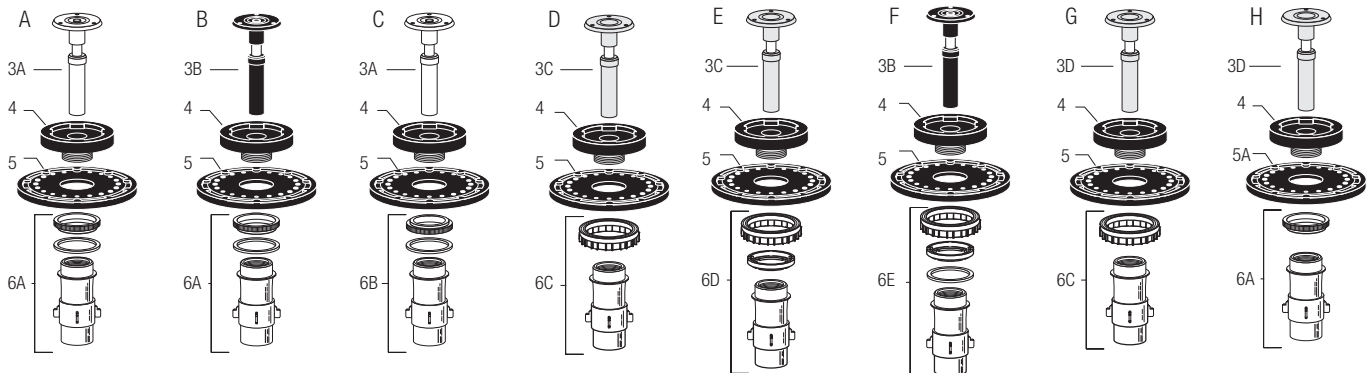

Regal® Flushometer

NOTE: Also for use with Regal® XL
(Since mid-2010)

TROUBLESHOOTING GUIDE

ATTENTION INSTALLERS: With the exception of the control stop inlet, DO NOT USE pipe sealant or plumbing grease on any valve component or coupling! To protect the chrome or special finish of Sloan flushometers, DO NOT USE toothed tools to install or service these valves. Use our A-50 Super-Wrench™ or other smooth-jawed wrench to secure couplings. Regulations for low consumption fixtures (1.6 gpf/6.0 Lpf closets and 1.0 gpf/3.8 Lpf urinals) prohibit use of higher flush volumes.

1. Flushometer DOES NOT function (no flush).

- A. Control stop or main valve is closed. Open control stop or main valve.
- B. Handle assembly is worn. Install handle repair kit B-50-A or replace handle.
- C. Relief valve is worn. Replace inside parts kit.

2. Insufficient volume of water to adequately siphon fixture.

- A. Control stop not open enough. Adjust control stop for desired delivery of water.
- B. Urinal flushometer parts inside a closet flushometer. Replace inside urinal parts with proper closet flushometer parts.
- C. Low consumption flushometer installed on a non-low consumption fixture. Replace A-41-A inside parts kit with A-38-A water saver kit.
- D. Water saver kit installed in old, non-water saver bowl. Position refill head A-170-1 so that SIDE 1 is in the UP position.
- E. Inadequate volume or pressure at supply. If no gauges are available to properly measure supply pressure or volume of water at the flushometer, then remove the relief valve from the inside parts kit, reassemble the flushometer and open the control stop.
 - If the fixture siphons, more water volume is required. If a 3.5 gpf inside parts kit is installed in the flushometer, then first flip the refill head (under the diaphragm) to obtain a 4.5 gpf volume. If this volume is still inadequate, remove the flow ring from the guide to obtain a 6.5 gpf kit. If additional flow is still required, try a low pressure guide kit A-175-A. **IMPORTANT: LAWS AND REGULATIONS PROHIBIT THE USE OF HIGHER FLUSHING VOLUMES THAN LISTED ON FIXTURE OR FLUSHOMETER.**
 - If fixture does not siphon or if a low consumption fixture is installed, or if the above steps do not prove satisfactory, steps must be taken to increase the pressure and/or supply.

3. Flushometer closes off immediately.

- A. Ruptured or damaged diaphragm. Install inside parts kit to correct above problems and update flushometer.
- B. Enlarged by-pass orifice from corrosion or damage. Install inside parts kit to correct above problem and update flushometer.

4. Length of flush is too short (short flushing).

- A. Diaphragm assembly and guide assembly are not hand-tight. Screw the two assemblies hand-tight.
- B. Enlarged by-pass orifice from corrosion or damage. Install NEW inside parts kit to correct problem and update flushometer.
- C. A-19-AU (black) urinal relief valve in closet flushometer. Replace relief valve with A-19-AC (white) closet relief valve.
- D. B-41-A low consumption kit installed in non-low consumption fixture. Replace with proper inside parts kit.
- E. Handle assembly is worn. Install handle repair kit B-50-A or replace the handle.

5. Length of flush is too long (long flushing) or fails to close off.

- A. Relief valve is not seating properly or by-pass orifice is clogged because of foreign material, or by-pass orifice is closed by an invisible gelatinous film from "over-treated" water. Disassemble the working parts and wash thoroughly.
NOTE: SIZE OF ORIFICE IN THE BY-PASS IS EXTREMELY IMPORTANT FOR PROPER METERING OF WATER INTO THE UPPER CHAMBER OF THE FLUSHOMETER. DO NOT ENLARGE OR DAMAGE THIS ORIFICE. REPLACE INSIDE KIT IF CLEANING DOES NOT CORRECT PROBLEM.
- B. Line pressure has dropped and is not sufficient to force relief valve to seat. Shut off all control stops until pressure has been restored, then open them again.
- C. A-19-AC (white) closet relief valve has been used in a 1 or 1-1/2 gpf urinal. Replace with A-19-AU (black) relief valve.
- D. Inside cover is cracked or damaged. Replace the inside cover A-71.

6. Chattering noise in flushometer.

- A. The A-156-A segment diaphragm has been installed upside-down. Replace the segment diaphragm to the proper position as instructed by markings on the diaphragm.
- B. The inside cover has been distorted from wear, freezing or abuse. replace inside cover.

7. Leaking at handle assembly.

- A. The B-39 seal is worn or deteriorated. Install new B-39 seal.
NOTE: The B-39 seal will easily slide right onto the B-40 bushing if it is wet.
- B. Handle gasket has been omitted. Install A-31 handle gasket or handle repair kit B-50-A.
- C. Valve handle bushing is worn. Install handle repair kit B-50-A.

CARE AND CLEANING INSTRUCTIONS

DO NOT USE abrasive or chemical cleaners (including chlorine bleach) to clean flushometers that may dull the luster and attack the chrome or special decorative finishes. Use **ONLY** mild soap and water, then wipe dry with a clean towel or cloth.

While cleaning the bathroom tile, protect the flushometer from any splattering of cleaner. Acids and cleaning fluids will discolor or remove chrome plating.

**When assistance is required, please contact
Sloan Technical Support at: 1-888-SLOAN-14 (1-888-756-2614).**

Series 900 Flushometer

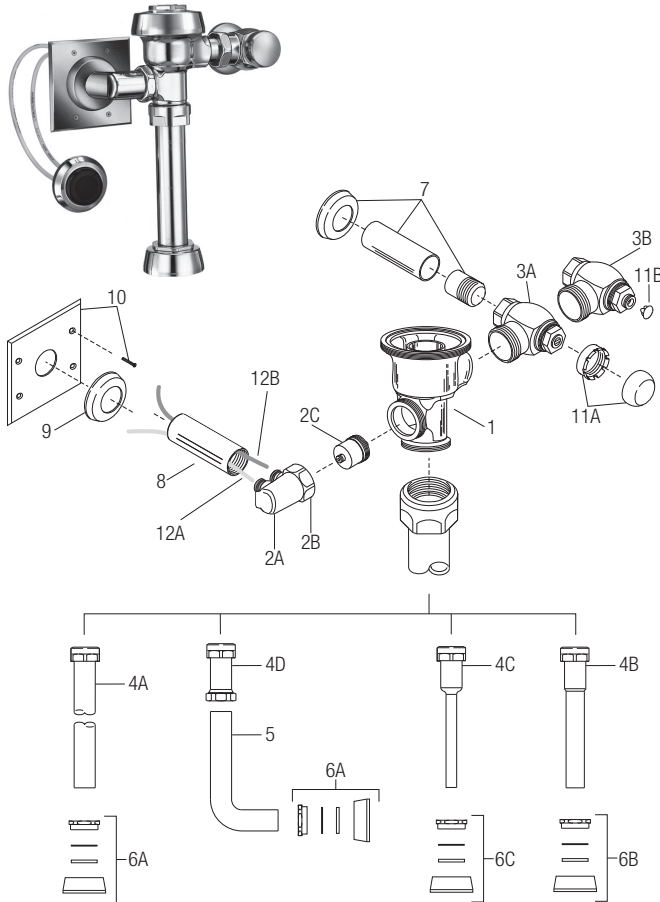

PARTS LIST FOR SERIES 900 EXPOSED FLUSHOMETER

Item No.	Code No.	Part No.	Description
1.	0301048	A-143-A	CP Valve Body w/2-1/16" Adj. Tailpiece
2A.	0318065PK	HY-65	Valve Actuator Housing (fittings not included)
2B.	0301082PK	A-6	Housing Nut
2C.	3318001PK	HY-83-A	Actuator Cartridge Assembly
3A.	3308386	H-700-A	Bak-Chek® Control Stop (Royal Valves) for 1" 3308384 for 3/4"
3B.	0388065	H-790-A	Bak-Chek® Control Stop (Regal XL Valves) for 1" 0388064 for 3/4"
4A.	3893004	V-600-AA	1 1/2" (38 mm) Vacuum Breaker Assembly
4B.	3393006	V-600-AA	1 1/4" (32 mm) Vacuum Breaker Assembly
4C.	3393004	V-600-AA	3/4" (19 mm) Vacuum Breaker Assembly
4D.	0393003	V-600-A	Short Vacuum Breaker
5.	0396293	F-109	1 1/2" (38 mm) Elbow Flush Connection
6A.	0306146	F-5-AT	1-1/2" (38 mm) Spud Coupling Assembly (Royal Valves)
	0306145	F-56-A	1 1/2" (38 mm) Spud Coupling Assembly (Regal XL Valves)
6B.	0306140	F-5-AU	1 1/4" (32 mm) Spud Coupling Assembly (Royal Valves)
	0306142	F-55-A	1 1/4" (32 mm) Spud Coupling Assembly (Regal XL Valves)
6C.	0306125	F-5-AW	3/4" (19 mm) Spud Coupling Assembly (Royal Valves)
	0306102	F-54-A	3/4" (19 mm) Spud Coupling Assembly (Regal XL Valves)
7.	3308782	H-633-AA	1" (25 mm) Sweat Solder Kit & Cast Wall Flange w/ Set Screw
	3308788	H-636-AA	3/4" (19 mm) Sweat Solder Kit & Cast Wall Flange w/ Set Screw
8.	0318064PK	HY-64	6" Chrome Sleeve
9.	‡	F-7	Supply Flange
10.	3318002	HY-112-A	Plate with Screws
11A.	3308772	H-1010-A	Free Spinning Vandal Resistant Stop Cap (Royal Valves)
11B.	5388002	H-528	Vandal Resistant Hole Plug (Regal Valves)
12A.	0318221	HY-146	1/4" (6mm) x 48" (1219 mm) Yellow connecting tube
12B.	0318217	HY-145	1/4" (6mm) x 48" (1219 mm) Blue connecting tube

† Part number varies with valve model variation; consult factory.

‡ Length varies with valve variation; consult factory.

Series 900 Flushometer

PARTS LIST FOR SERIES 900 CONCEALED FLUSHOMETER

Item No.	Code No.	Part No.	Description
1.	0301173	A-72	RB Royal® Cover
2.	0301168	A-71	Inside Cover
3.	SEE THE INSIDE PARTS KIT CHART ON NEXT PAGE		
4.	3323182	V-651-A	Vacuum Breaker Repair Kit
5.	0308690	H-550	RB Tailpiece Coupling
6.	0308802	H-551-A	RB Adjustable Tailpiece, 2-1/16" (52 mm)
7A.	5308696	H-553	O-ring – 24 per package
7B.	5308381	H-552	Locking ring – 12 per package
8.	0388010	H-730-A	RB Wheel Handle Bak-Chek® Control Stop
9A.	3308855	H-541-A	1" Wheel Handle Repair Kit for H-730-A Control Stop
9B.	3308858	H-543-A	3/4" Wheel Handle Repair Kit for H-730-A Control Stop
10.	0308919	H-558-A	Wheel Handle
11A.	0208083PK	H-623	1" & 3/4" RB Bonnet for 700 series stops
12.		V-500-AA	Royal Vacuum Breaker Flush Connection (specify length and size)
13.	0306619	F-2-AA	1-1/2" (38 mm) RB Couplings (2 each), Friction Rings (2 each), and Rubber Gaskets (2 each)
14.	0206146PK	F-21	RB Elbow
15.	0306091	F-2-A	1-1/2" (38 mm) RB Coupling and S-21 Flat Rigid Gasket
16.		F-100	RB Flared End Flush Connection (specify length)
17.		F-15-A	3/4" (19 mm) RB Elbow Flush Connection with Coupling and Rubber Gasket (specify length)
18.	0306054	F-2-A	3/4" (19 mm) RB Coupling, Friction Ring, and Rubber Gasket
19.	0318024	HY-25-1	RB Valve Actuator Housing
20A.	0318221	HY-146	1/4" (6 mm) x 48" (1219 mm) Yellow Connecting Tubes (2 required)
20B.	0318217	HY-145	1/4" (6 mm) x 48" (1219 mm) Blue Connecting Tubes (2 required)
21.	0301083PK	A-6	RB Handle Coupling Nut
22.	3318005	HY-109-A	Actuator Housing Assembly (includes items 21 & 24)
23.	3318001	HY-83-A	Actuator Cartridge Assembly
24.	0337086	DO-22	O-ring for HY-109-A Adapter
25.	SEE SLIP JOINT GASKETS AND RINGS TABLE BELOW		
26.	0301050	A143-A	RB Valve Body w/2-1/16" Adj. Tailpiece

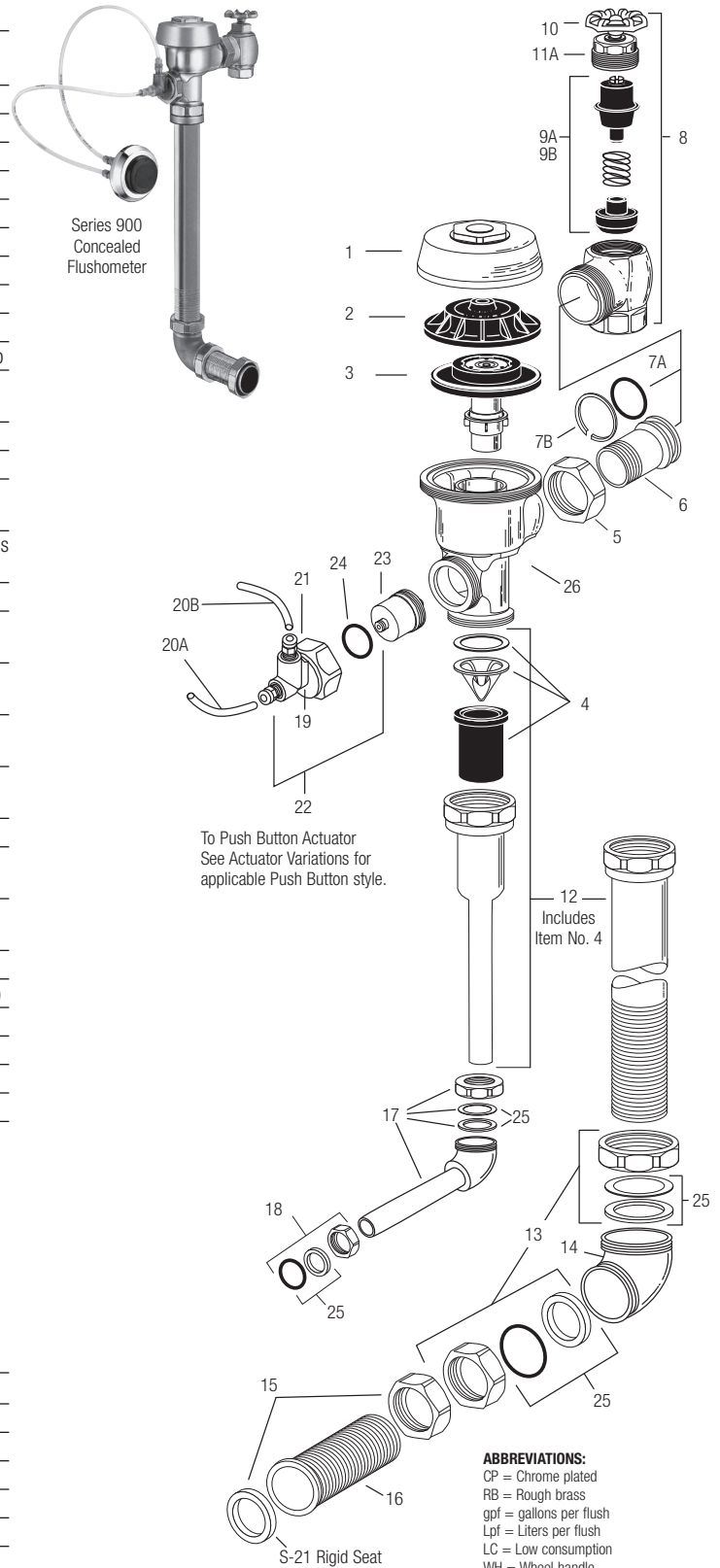

ITEM 27. SLIP JOINT GASKETS AND RINGS

Size	Code No.	Part No.	Description
1-1/2"	5306058	F-3	Red Friction Ring
	5322001	VPF-5	Black Slip Joint Gasket
	5319086	S-30	Flexible Seat
	0319079	S-21	Rigid Seat (rubber over brass)
1-1/2" x 1-1/4"	0396062	F-105	Slip Joint Gasket – Rigid
1-1/4"	5306057	F-3	Red Friction Ring
	5322176	VPF-5	Black Slip Joint Gasket
	0307052/5307052	G-21	Rigid Seat (rubber over brass)
	5306056	F-3	Red Friction Ring
1"	5306115	F-5	Black Slip Joint Gasket
	5306055	F-3	Red Friction Ring
3/4"	5306113	F-5	Black Slip Joint Gasket

TAILPIECES, CONTROL STOPS, PUSH BUTTONS AND FLUSH CONNECTIONS

For additional information on tailpieces, control stops, push buttons and flush connections see Showerheads, Parts and Accessories Tab.

Series 900 Flushometer

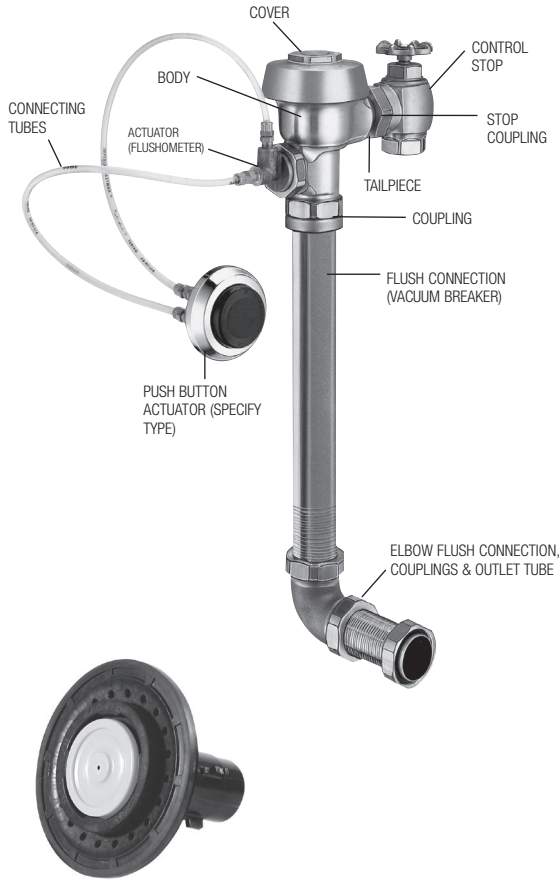

Regal Flushometer

DIAPHRAGM INSIDE PARTS KITS

Code No.	Part No.	Application
3301036	A-36-A	4.5 gpf/17.0 Lpf - Closet
3301037	A-37-A	1.5 gpf/5.7 Lpf - Urinal
3301038	A-38-A	3.5 gpf/13.2 Lpf - Closet
3301041	A-41-A	1.6 gpf/6.0 Lpf - Closet
3301044	A-42-A	1.0 gpf/3.8 Lpf - Urinal
3301081	A-43-A	0.5 gpf/1.9 Lpf - Urinal
3301024	A-44-A	2.4 gpf/9.0 Lpf - Closet
3301045	A-140-A	1.28 gpf/4.8 Lpf - Closet

INSIDE PARTS COMPONENTS

Code No.	Part No.	Description
5301058	A-19-AC	Relief Valve, White (Closet) – 12 per pkg.
5301059	A-19-AU	Relief Valve, Black (Urinal) – 12 per pkg.
5301211	A-19-ALC	Relief Valve, Green (Closet/Urinal-LC) – 12 per pkg.
0301143	A-19-AL	Relief Valve, Blue (9 Liter Closet)
5301111	A-15-A	Disc – for all Inside Parts Kits – 12 per pkg.
5301188	A-156-A	Diaphragm – for all Inside Parts Kits – 12 per pkg.
5301236	A-163-A	Guide Assembly 4.5 gpf/17.0 Lpf Closet & 1.5 gpf/5.7 Lpf Urinal – 12 per package
5301032	A-152-A	Guide Assembly 3.5 gpf/13.2 Lpf Closet – 12 per package
5301031	A-151-A	Guide Assembly 1.6 gpf/6.0 Lpf LC Closet – 12 per package
5301155	A-155-A	Guide Assembly 1.0 gpf/3.8 Lpf LC Urinal – 12 per package
5301157	A-157-A	Guide Assembly 0.5 gpf/1.9 Lpf Urinal – 12 per package

Royal Flushometer

ITEM 3 INSIDE PARTS KITS (SEE ILLUSTRATION ON PREVIOUS PAGE)

Code No.	Part No.	Application
3301118	A-1048-A-BX	High Efficiency Water Closets 1.1 gpf (4.2 Lpf)
3301502	A-1041-A	Low Consumption Water Closets- 1.6 gpf (6.0 Lpf)*
3301501	A-1038-A	Water Saver Water Closets-3.5 gpf (13.2 Lpf)*
3301505	A-1044-A	9 Liter European Water Closets-2.4 gpf (9.0 Lpf)
3301504	A-1043-A	Wash Down Urinals-0.5 gpf (1.9 Lpf)
3301503	A-1042-A	Low Consumption Urinals-1.0 gpf (3.8 Lpf)*
3301500	A-1037-A	Water Saver Urinals-1.5 gpf (5.7 Lpf)*
3301506	A-1045-A	High-Efficiency Water Closets-1.28 gpf (4.8 Lpf)

* WATER SAVER (3.5 GPF CLOSET AND 1.5 GPF URINAL) AND LOW CONSUMPTION (1.6 GPF CLOSET AND 1.0 GPF URINAL) FIXTURES MUST USE MATCHING GPF (LPF) DIAPHRAGM KITS; USING A SMALLER GPF (LPF) KIT IN FIXTURES NOT INTENDED FOR LESS VOLUME WILL RESULT IN INADEQUATE DILUTION IN URINALS AND IMPROPER EVACUATION IN CLOSETS. HY-1101-A

HYDRAULIC INSIDE PARTS REPAIR KITS

Code No.	Part No.	Description
3318011	HY-1101-A	Hydraulic Royal 1.6C
3318012	HY-1102-A	Hydraulic Royal 3.5C
3318013	HY-1103-A	Hydraulic Royal 2.4C
3318014	HY-1106-A	Hydraulic Royal 0.5U
3318015	HY-1107-A	Hydraulic Royal 1.0U
3318016	HY-1108-A	Hydraulic Royal 1.5U

Comes with: Diaphragm, Actuator Cartridge Assembly, Tailpiece O-ring and Vacuum Breaker Assembly



Sloan Flushometer

DIAPHRAGM INSIDE PARTS KITS

Includes Relief Valve and Diaphragm Assembly

Code No.	Part No.	Application
3378041	SV-41-A	1.6 gpf/6.0 Lpf - Closet
3378038	SV-38-A	3.5 gpf/13.2 Lpf - Closet
3378044	SV-44-A	2.4 gpf/9.0 Lpf - Closet
3378037	SV-37-A	1.5 gpf/5.7 Lpf - Urinal
3378042	SV-42-A	1.0 gpf/3.8 Lpf - Urinal
3378043	SV-43-A	0.5 gpf/1.9 Lpf - Urinal
3378047	SV-47-A	1.28 gpf/4.8 Lpf - Closet

INSIDE COMPONENTS

Code No.	Part No.	Description
5301211	A-19-ALC	Relief Valve, Green (Closet/Urinal-LC) – 12 per package
5301058	A-19-AC	Relief Valve, White (Closet) – 12 per package
0301143	A-19-AL	Relief Valve, Blue (9 Liter Closet)
5301059	A-19-AU	Relief Valve, Black (Urinal) – 12 per package

Series 900® Flushometer

HY-49-A (0318049) METAL PARTITION PUSH BUTTON

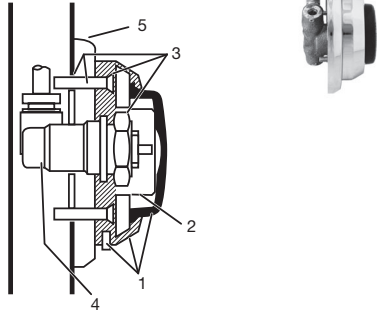

Item No.	Code No.	Part No.	Description
1.	0318002	HY-1-A	Push Button Kit – includes Push Button, Flange, Spring & Set Screws
2.	0318004PK	HY-3	Spring
3.	0318003	HY-2-A	Mounting Flange Kit – includes Mounting Flange, Mounting Nut, Screws (2) & Tinnerman Nuts (2)
4.	0318123	HY-71-A	Actuator Assembly
5.	0318123	HY-46-A	Wall Flange

NOTE: Includes HY-32-A cartridge (shown at right)
NOTE: Maximum distance from button to valve is 20' (longer tubing required)

HY-72-A (0318072) SIDE WALL PUSH BUTTON

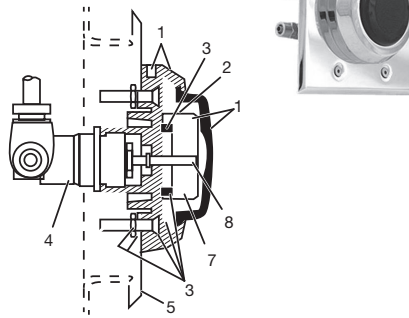

Item No.	Code No.	Part No.	Description
1.	3318007	HY-1000-A	Push Button Kit – includes Push Button, Flange, Spring & Set Screw
2.	0318004PK	HY-3	Spring
3.	3318008	HY-1001-A	Mounting Flange Kit – includes Mounting Flange, Mounting Nut, Screws (2), Nuts (2) & Washers (2)
4.	0318123	HY-71-A	Actuator Assembly
5.	0318041	HY-40	Plate
6.	0318073PK	HY-73	Extension Adapter
7.	0318074PK	HY-74	Extension Stem

NOTE: Includes HY-32-A cartridge (shown at right)
NOTE: Maximum distance from button to valve is 20' (longer tubing required)
NOTE: HY-30 84" longer tubing (0318094)

HY-108-A (0318119) PENAL WARE METAL PUSH BUTTON

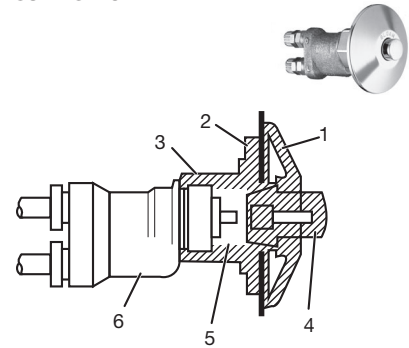

Item No.	Code No.	Part No.	Description
1.	0318116PK	HY-91	Flange
2.	0318111PK	HY-94	Mounting Washer
3.	0318112PK	HY-93	Mounting Nut
4.	0318115	HY-86-A	Push Button Assembly
5.	0305134PK	EL-109	Spring
6.	0318078	HY-50-A	Actuator Assembly

NOTE: Includes HY-32-A cartridge (shown below)
NOTE: Maximum distance from button to valve is 20' (longer tubing required)
NOTE: HY-30 84" longer tubing (0318094)

HY-32-A ACTUATOR CARTRIDGE ASSEMBLY

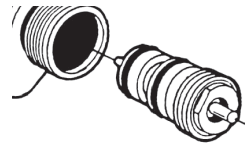

For use with HY-50-A and HY-71-A actuator assemblies



NOTE: Prior to 2025, the HY-32-A (0318031) Actuator Cartridge was made of brass. Beginning in 2025, the HY-32-A is made of gray polymer.

HY-100-A (0318117) FIXTURE WALL METAL PUSH BUTTON

Item No.	Code No.	Part No.	Description
1.	0318117	HY-100-A	Fixture Wall Metal Button Assembly
2.	3318006	HY-111-A	Metal Button Kit
3.	0305134PK	EL-109	Spring
4.	0318078	HY-50-A	Actuator Assembly
5.	0318028PK	HY-29	Threaded Rod
6.	0318109PK	HY-105	Spacer
7.	3318009	HY-1002-A	Mounting Strap Kit

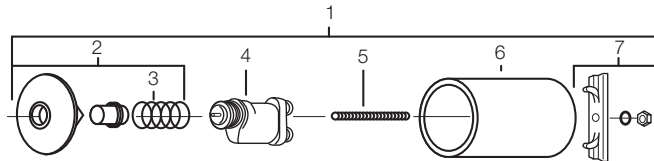

HY-33-A (0318001) FIXTURE WALL PUSH BUTTON

1.	0318001	HY-33-A	Fixture Wall Push Button Assembly
2.	3318007	HY-1000-A	Push Button Kit
3.	0318004PK	HY-3	Spring
4.	3318008	HY-1001-A	Mounting Flange Kit
5.	0318078	HY-50-A	Actuator Assembly
6.	0318028PK	HY-29	Threaded Rod
7.	0318109PK	HY-105	Spacer
8.	3318009	HY-1002-A	Mounting Strap Kit

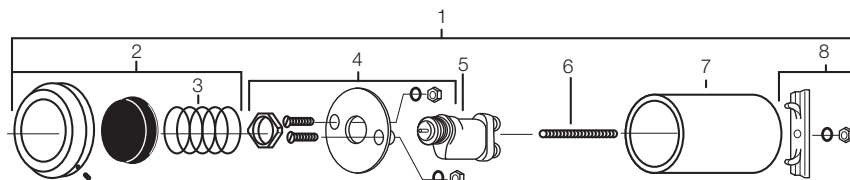

Series 900® Flushometer

HY-113-A (0318120) METAL PUSH BUTTON PANEL MOUNT (MBPM VARIATION)

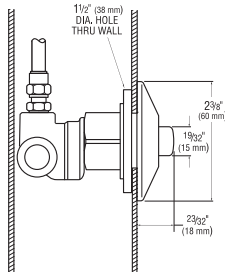

HY-100-A (0318117) METAL PUSH BUTTON PANEL MOUNT (MBFW VARIATION)

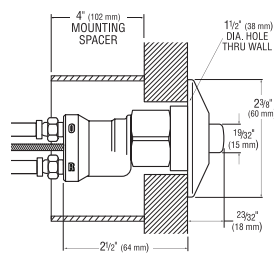

HY-125-A (0318183) METAL PUSH BUTTON FIXTURE WALL (FW VARIATION)

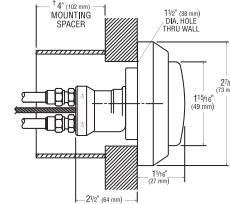

[†] Use Mounting Spacer only if wall thickness is less than 2" (50 mm).

Item

No.	Code No.	Part No.	Description
1.	0318115	HY-86-A	Push Button Kit – includes Push Button, Flange, Spring & Set Screw
2.	0305134	EL-109	Spring
3.	0318111	HY-94-A	Mounting Flange Kit – includes Mounting Nut, Screws (2) & Tinnerman Nuts (2)
4.	0318123	HY-91-A	Flange

NOTE: Includes HY-32-A cartridge (0318031)
NOTE: Maximum distance from button to valve is 20'
(longer tubing required)
NOTE: HY-30 84" longer tubing (0318094)

HY-79-A (0318081) METAL PARTITION PUSH BUTTON

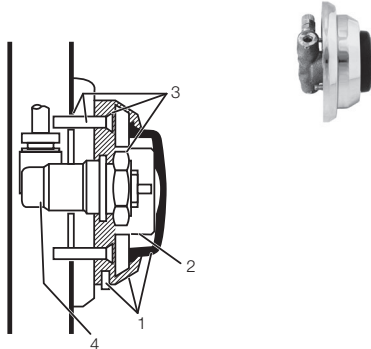

Item

No.	Code No.	Part No.	Description
1.	0318002	HY-1-A	Push Button Kit – includes Push Button, Flange, Spring & Set Screw
2.	0318004	HY-3	Spring
3.	0318003	HY-2-A	Mounting Flange Kit – includes Mounting Flange, Mounting Nut, Screws (2) & Tinnerman Nuts (2)
4.	0318123	HY-71-A	Actuator Assembly

NOTE: Includes HY-32-A cartridge (shown at right)
NOTE: Maximum distance from button to valve is 20'
(longer tubing required)

Item

No.	Code No.	Part No.	Description
1.	0318115	HY-86-A	Push Button Kit – includes Push Button, Flange, Spring & Set Screw
2.	0318109	HY-105	Spacer Mounting Tube
3.	0318125	HY-95-A	Mounting Flange Kit – includes Mounting Flange, Mounting Nut, Screws (2), Nuts (2) & Washers (2)
4.	0318123	HY-4-A	RB Actuator Assembly
5.	0318019	HY-20-A	Inner Bushing
6.	0305173	HY-4	RB Body Hyd Actuator

NOTE: Includes HY-32-A cartridge (0318031)
NOTE: Maximum distance from button to valve is 20'
(longer tubing required)
NOTE: HY-30 84" longer tubing (0318094)

Item

No.	Code No.	Part No.	Description
1.	0318002	HY-1	CP Button Flange
2.	0318111	HY-105	Spacer Mounting Tube
3.	0318003	HY-2	RB Mounting Nut
4.	0318067	HY-123-A	Push Button Assembly
5.	0318078	HY-50-A	Actuator Assembly

NOTE: Includes HY-32-A cartridge (shown below)
NOTE: Maximum distance from button to valve is 20'
(longer tubing required)
NOTE: HY-30 84" longer tubing (0318094)



Series 900 Flushometer

TROUBLESHOOTING GUIDE

1. Push button leaks.

The actuator cartridge has an accumulation of lime or its seals are damaged or worn. Replace with a new HY-32-A cartridge.

2. The flushometer DOES NOT flush and a small amount of leakage is visible below the valve.

- A. Foreign material lodged in the cartridge. Remove the cartridge and inspect for foreign material. Clean under running water.
- B. The actuator cartridge has an accumulation of lime or its seals are damaged or worn. Replace with a new HY-32-A cartridge.
- C. Plastic tubing is installed incorrectly. Install plastic tubing correctly.

ACTUATOR CARTRIDGE REMOVAL

Plastic Push Button Actuator Removal:

- (1) Loosen the setscrew in the button flange and remove the button, flange, and spring from the actuator body.
- (2) Unscrew the cartridge from the actuator body.

Metal Push Button Actuator Removal:

- (1) Remove the button or actuator assembly from the wall or fixture.
- (2) Disassemble the flange or button assembly from the actuator body.
- (3) Unscrew the cartridge from the actuator body.

NOTE: The metal push button is designed to be vandal-proof and must be removed from the wall or fixture for service.

3. The flushometer DOES NOT flush or flushes only once and will not flush a second time when the button is pushed.

- A. The plunger is lodged in the actuator cartridge or the plunger bypass hole is clogged. Remove actuator housing and cartridge from the flushometer. Clean under running water. If cartridge parts are worn, deteriorated or limed up and problem persists after cleaning, replace with a new HY-83-A cartridge.
- B. Plastic tubing is installed incorrectly. Install plastic tubing correctly (Blue tube/Blue fitting, Yellow tube/Yellow fitting).

REMOVAL OF THE ACTUATOR FROM THE FLUSHOMETER:

Turn off water at the control stop. Unscrew the actuator housing coupling nut from the flushometer. Remove the actuator housing from the flushometer. The tubing connections can be left intact. Carefully remove the actuator cartridge from the flushometer body to prevent the actuator from abrupt separation due to expansion of an internal spring. If the actuator cartridge is lodged in the flushometer body cavity, gently grip the exposed portion of the cartridge with a channel-lock pliers and rotate back and forth to loosen the o-ring seal. Carefully separate the actuator housing to reveal the spring and plunger.

4. Flushometer DOES NOT function (no flush).

- A. Control stop or main valve is closed. Open control stop or main valve.
- B. Relief valve is worn. Replace performance kit (Royal) or inside parts kit (Regal XL).

5. Volume of water is not sufficient to siphon fixture.

- A. Control stop is not open wide enough. Adjust control stop for desired delivery of water volume.
- B. Urinal flushometer parts installed in a closet flushometer. Replace inside urinal flushometer parts with proper closet flushometer parts.
- C. Incorrect dual-filtered diaphragm assembly (Royal) or inside parts kit (Regal XL) is installed in flushometer; for instance, urinal assembly inside a closet flushometer, or low consumption assembly inside a higher consumption fixture. Determine the flush volume required by the fixture and replace Royal performance kit or inside parts kit. Use valve label and markings on fixture for reference.
- D. Water supply volume or pressure is inadequate. If no gauges are available to properly measure supply pressure or volume of water at the flushometer, then remove the relief valve from the dual-filtered diaphragm assembly (Royal) or inside parts kit (Regal XL), reassemble the flushometer and completely open the control stop. If the fixture siphons, more water volume is required.

For Royal — Install a higher flushing volume Royal Performance Kit.

For Regal XL — If a 3.5 gpf Inside Parts Kit is installed in the flushometer, then first flip the refill head (under the diaphragm) to obtain a 4.5 gpf volume. If this volume is still inadequate, remove the flow ring from the guide to obtain a 6.5 gpf Kit. If additional flow is still required, try a low pressure guide kit A-175-A (0301104).

IMPORTANT — LAWS AND REGULATIONS REQUIRING PROHIBIT THE USE OF HIGHER FLUSHING VOLUMES THAN LISTED ON FIXTURE OR FLUSHOMETER.

If the fixture does not siphon or if a low consumption flush is required, steps must be taken to increase the water supply pressure and/or volume. Contact the fixture manufacturer for minimum water supply requirements of the fixture.

6. Flushometer closes off immediately.

- A. Ruptured or damaged diaphragm. Replace Royal performance kit (Royal) or inside parts kit (Regal XL).
- B. **For Regal XL** — An enlarged bypass orifice from corrosion or damage. Replace inside parts kit.

7. Length of flush is too short (short flush)

- A. **For Regal XL** — The diaphragm assembly and guide assembly are not hand tight. Screw the two assemblies hand tight.
- B. **For Regal XL** — An enlarged bypass orifice from corrosion or damage. Replace inside parts kit.
- C. Dual-filtered diaphragm assembly (Royal) or inside parts kit (Regal XL) is damaged. Replace Royal performance kit or inside parts kit.
- D. Incorrect dual-filtered diaphragm assembly (Royal) or inside parts kit (Regal XL) is installed in flushometer; for instance, urinal assembly inside a closet flushometer, or low consumption assembly inside a higher consumption fixture. Determine the flush volume required by the fixture and replace Royal performance kit or inside parts kit. Use valve label and markings on fixture for reference.

Series 900 Flushometer

TROUBLESHOOTING GUIDE (CONTINUED)

8. Length of flush is too long (long flush) or continuous.

- A. **For Royal** — Metering bypass hole in diaphragm is clogged. Remove the dual-filtered diaphragm assembly. Remove the primary and secondary filter rings from the diaphragm and wash under running water. Replace Royal performance kit if cleaning does not correct the problem.
- B. **For Regal XL** — Relief valve (A-19-A) is not seating properly or bypass orifice is clogged. Disassemble the working parts and wash thoroughly.

NOTE: SIZE OF THE ORIFICE IN THE BYPASS IS OF UTMOST IMPORTANCE FOR THE PROPER METERING OF WATER INTO THE UPPER CHAMBER OF THE FLUSHOMETER. DO NOT ENLARGE OR DAMAGE THIS ORIFICE. REPLACE INSIDE PARTS KIT IF CLEANING DOES NOT CORRECT PROBLEM.

- C. Supply line water pressure has dropped and is not sufficient to close the valve. Close control stop until pressure is restored.
- D. Dual-filtered diaphragm assembly (Royal) or inside parts kit (Regal XL) is damaged. Replace Royal performance kit or inside parts kit.
- E. Incorrect dual-filtered diaphragm assembly (Royal) or inside parts kit (Regal XL) is installed in flushometer; for instance, urinal assembly inside a closet flushometer, or low consumption assembly inside a higher consumption fixture. Determine the flush volume required by the fixture and replace Royal performance kit or inside parts kit. Use valve label and markings on fixture for reference.
- F. White closet relief valve has been used in a urinal flushometer. Replace closet relief valve (A-19-AC) with black urinal relief valve (A-19-AU).
- G. Inside cover is cracked or damaged. Replace the inside cover (A-71).
- H. Conditions in the piping system may contribute to the noise. A degree of high pressure in the piping may be relieved by adjustments to control stop. Other noises created by loose pipes, lack of air chambers, inadequate pipe sizes, etc., are problems that must be discussed with the building engineer.

9. Chattering noise is heard during flush.

- A. Inside cover is damaged. Replace inside cover (A-71).
- B. **For Regal XL** — A-156-A segment diaphragm has been installed upside-down. Reposition the segment diaphragm properly (see markings on the diaphragm).

CARE AND CLEANING INSTRUCTIONS

DO NOT USE abrasive or chemical cleaners (including chlorine bleach) to clean flushometers that may dull the luster and attack the chrome or special decorative finishes. Use **ONLY** mild soap and water, then wipe dry with a clean towel or cloth.

While cleaning the bathroom tile, protect the flushometer from any splattering of cleaner. Acids and cleaning fluids will discolor or remove chrome plating.

When assistance is required, please contact Sloan Technical Support at: 1-888-SLOAN-14 (1-888-756-2614).

Concealed Flushometer (Royal®)

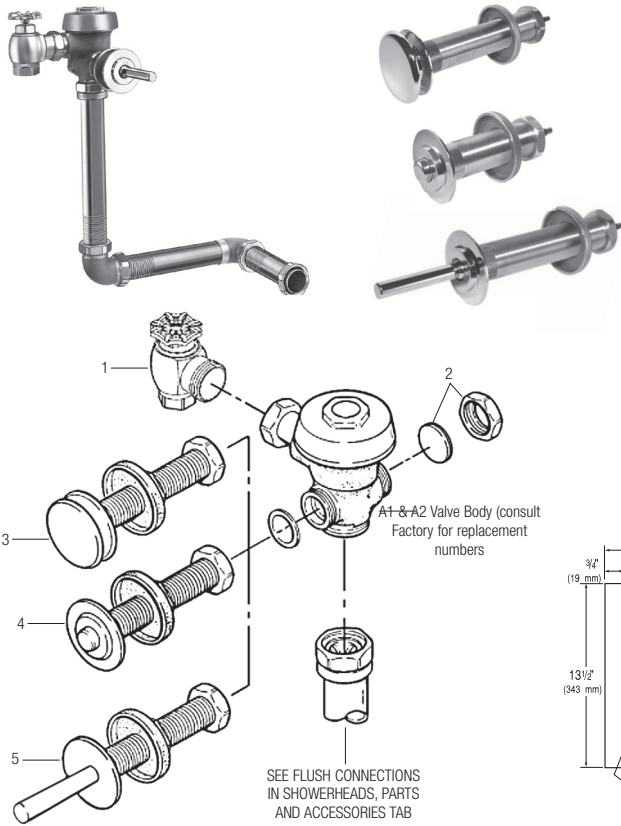

TAILPIECES, CONTROL STOPS, FLUSH CONNECTIONS AND HANDLE ASSEMBLIES

For additional information on tailpieces, control stops, flush connections, and handle assemblies see Showerheads, Parts and Accessories Tab.

PARTS LIST

Item No.	Code No.	Part No.	Description
1.	0388010	H-730-A	1" RB Wheel Handle Bak-Chek® Control Stop
	0388011	H-730-A	3/4" RB Wheel Handle Bak-Chek® Control Stop
2.	3301093	A-1013-A	Concealed Valve Handle Cap Kit
FOR SPECIFYING PROPER LENGTHS FOR ITEMS 3, 4 AND 5, SEE CHART BELOW			
3.	—	C-43-A	3" (76 mm) Push Button Actuator Assembly
4.	—	C-9-A	Blind Nut Push Button Actuator Assembly
5.	—	B-12-A	Lever Actuator Assembly
6.	—	C-43-AWB	Wall Box Push Button Assembly
7.	—	C-9-A WB	Wall Button Push Button Actuator Assembly
8.	—	B-12-AWB	Wall Box Lever Actuator Assembly (Not Shown)

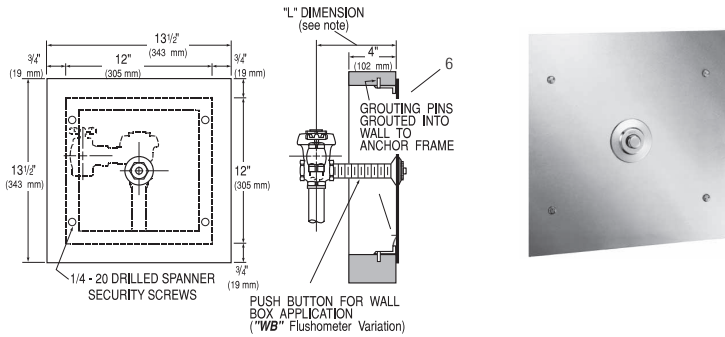

Specify the "L" dimension for the proper length of the push button assembly

"L" dimension PUSH BUTTON ID CHART (all dimensions in inches)

Wall Thickness	1	2	3	4	5	6	7	8	9	10	11	12	13	14	15
"L" Dimension	3 3/4	4 3/4	5 3/4	6 3/4	7 3/4	8 3/4	9 3/4	10 3/4	11 3/4	12 3/4	13 3/4	14 3/4	15 3/4	16 3/4	17 3/4
"A" (B-15-A) Filler Rod	1 5/8	2 5/8	3 5/8	4 5/8	5 5/8	6 5/8	7 5/8	8 5/8	9 5/8	10 5/8	11 5/8	12 5/8	13v5/8	14 5/8	15 5/8
"B" (B-6-A) Socket Assembly	2 1/2	3 1/2	4 1/2	5 1/2	6 1/2	7 1/2	8 1/2	9 1/2	10 1/2	11 1/2	12 1/2	13 1/2	14 1/2	15 1/2	16 1/2

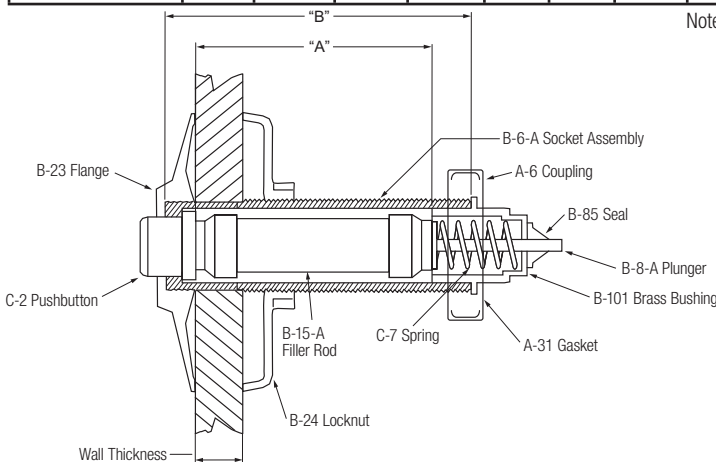

- Notes: 1. "L" Dimension = Wall thickness (to nearest whole inch) + 2 3/4"
 2. 1 1/2" Diameter Hole Opening Required Through Wall

Concealed Flushometer (Royal®)

TROUBLESHOOTING GUIDE

ATTENTION INSTALLERS: With the exception of the control stop inlet, **DO NOT USE** pipe sealant or plumbing grease on any valve component or coupling! To protect the chrome or special finish of Sloan flushometers, **DO NOT USE** toothed tools to install or service these valves. Use our A-50 Super Wrench or other smooth-jawed wrench to secure couplings. Regulations for low consumption fixtures (1.6 gpf/6.0 Lpf closets and 1.0 gpf/3.8 Lpf urinals) prohibit use of higher flush volumes.

1. Flushometer DOES NOT function.

- Control stop or main valve is closed. Open control stop or main valve.
- Handle or push button assembly is worn. Install Sloan handle repair kit (C-70-A) or replace handle or push button.
- Relief valve is worn. Replace inside parts kit.

2. Insufficient volume of water to adequately siphon fixture.

- Control stop not open enough. Adjust control stop for desired delivery of water.
- Urinal flushometer parts inside a closet flushometer. Replace inside urinal parts with proper closet flushometer Parts.
- Low consumption flushometer installed on a non-low consumption fixture. Replace A-41-A inside parts kit with A-38-A water saver kit.
- Water saver kit installed in old, non-water saver bowl. Position refill head A-170 so that SIDE 1 is in the UP position.
- Inadequate volume or pressure at supply.
 - If no gauges are available to properly measure supply pressure or volume of water at the flushometer, then remove the relief valve from the inside parts kit, reassemble the flushometer and open the control stop. If the fixture siphons, more water volume is required. If a 3.5 gpf inside parts kit is installed in the flushometer, then first flip the refill head (under the diaphragm) to obtain a 4.5 gpf volume. If this volume is still inadequate, remove the flow ring from the guide to obtain a 6.5 gpf kit. If additional flow is still required, try a low pressure guide kit A-175-A (#0301104).
IMPORTANT: Laws and regulation prohibit the use of higher flushing volumes than listed on fixture or flushometer.
 - If fixture **DOES NOT** siphon or if a low consumption fixture is installed, or if the above steps do not prove satisfactory, steps must be taken to increase the pressure and/or supply.

3. Flushometer closes off immediately.

- Ruptured or damaged diaphragm. Install inside parts kit to correct problem and update flushometer.
- Enlarged bypass orifice from corrosion or damage. Install inside parts kit to correct problem and update flushometer.

4. Length of flush is too short (short flushing).

- Diaphragm assembly and guide assembly are not hand-tight. Screw the two assemblies hand-tight.
- Enlarged bypass orifice from corrosion or damage. Install NEW inside parts kit to correct problem and update flushometer.
- A-19-AU (Black) urinal relief valve in closet flushometer. Replace relief valve with A-19-AC (White) closet relief valve.
- A-41-A low consumption kit installed in non-low consumption fixture. Replace with proper Inside Parts Kit.
- Handle assembly is worn. Install handle repair kit (C-70-A) or replace the handle.

5. Length of flush is too long (Long Flushing) or fails to close off.

- Relief valve is not seating properly or bypass orifice is clogged because of foreign material, or bypass orifice is closed by an invisible gelatinous film from "over-treated" water. Disassemble the working parts and wash thoroughly. NOTE: SIZE OF ORIFICE IN THE BYPASS IS EXTREMELY IMPORTANT FOR PROPER METERING OF WATER INTO THE UPPER CHAMBER OF THE FLUSHOMETER. DO NOT ENLARGE OR DAMAGE THIS ORIFICE. REPLACE INSIDE KIT IF CLEANING DOES NOT CORRECT PROBLEM.
- Line pressure has dropped and is not sufficient to force relief valve to seat. Shut off all control stops until pressure has been restored, then open them again.
- A-19-AC (White) closet relief valve has been used in a 1.0 or 1.5 gpf urinal. Replace with A-19-AU (Black) relief valve.
- Inside cover is cracked or damaged. Replace the inside cover (A-71).

6. Chattering noise in flushometer.

- The A-156-A segment diaphragm has been installed upside-down. Replace the segment diaphragm to the proper position as instructed by markings on the diaphragm.
- The inside cover has become distorted from wear, freezing or abuse. Replace inside cover.

7. Leaking at handle or push button assembly.

- The B-39 Seal is worn or deteriorated. Install new B-39 seal. NOTE: The B-39 Seal will easily slide onto the B-40 Bushing if it is wet.
- Handle gasket has been omitted. Install A-31 handle gasket or Sloan handle repair kit (C-70-A).
- Valve handle bushing is worn. Install Sloan handle repair kit (C-70-A).

CARE AND CLEANING INSTRUCTIONS

DO NOT USE abrasive or chemical cleaners (including chlorine bleach) to clean flushometers that may dull the luster and attack the chrome or special decorative finishes. Use **ONLY** mild soap and water, then wipe dry with a clean towel or cloth.

While cleaning the bathroom tile, protect the flushometer from any splattering of cleaner. Acids and cleaning fluids will discolor or remove chrome plating.

When assistance is required, please contact Sloan Technical Support at: 1-888-SLOAN-14 (1-888-756-2614).

Crown® Flushometer

Crown® II (DISCONTINUED)

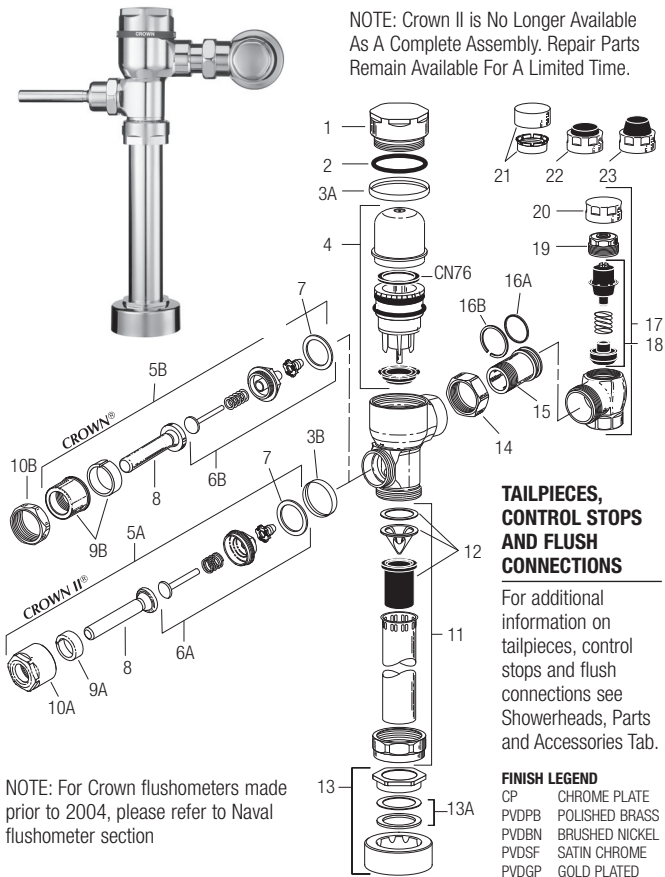

NOTE: Crown II is No Longer Available As A Complete Assembly. Repair Parts Remain Available For A Limited Time.

TAILPIECES, CONTROL STOPS AND FLUSH CONNECTIONS

For additional information on tailpieces, control stops and flush connections see Showerheads, Parts and Accessories Tab.

FINISH LEGEND

CP	CHROME PLATE
CP	CHROME PLATE
PVDPB	POLISHED BRASS
PVDBN	BRUSHED NICKEL
PVDSF	SATIN CHROME
PVDGP	GOLD PLATED

NOTE: For Crown flushometers made prior to 2004, please refer to Naval flushometer section

PARTS LIST

Item No.	Code No.	Part No.	Description
1.	0332006PK	CR-116	CP Cover
2.	5332030	CR-133	Cover O-ring (6 Pack)
3.	0332045	CR-132-A	CP Handle and Cover Trim Ring Kit (Includes items 3A & 3B) (CROWN® II ONLY)
	0332046	CR-132-A	PVDPB Handle and Cover Trim Ring Kit (Includes items 3A & 3B) (CROWN® II ONLY)
	0332048	CR-132-A	PVDBN Handle and Cover Trim Ring Kit (Includes items 3A & 3B) (CROWN® II ONLY)
	0332049	CR-132-A	PVDSF Handle and Cover Trim Ring Kit (Includes items 3A & 3B) (CROWN® II ONLY)
3A.	0332035	CR-134	Cover Trim Ring (CROWN® ONLY)
	0332009	CR-120	PVDPB Cover Trim Ring (CROWN® II ONLY) Discontinued
	0332032	CR-120	PVDGP Cover Trim Ring (CROWN® II ONLY) Discontinued
	0332033	CR-120	PVDBN Cover Trim Ring (CROWN® II ONLY) Discontinued
	0332034	CR-120	PVDSF Cover Trim Ring (CROWN® II ONLY) Discontinued
3B.	0332005	CR-113	PVDPB Handle Trim Ring (CROWN® II ONLY) Discontinued
	0332028	CR-113	PVDBN Handle Trim Ring (CROWN® II ONLY) Discontinued
	0332029	CR-113	PVDSF Handle Trim Ring (CROWN® II ONLY) Discontinued
4.	3332003	CR-1004-A	Piston Kit – 1.6 gpf (6.0 Lpf) Water Closet
	3332013	CR-1011-A	Piston Kit – 1.28 gpf (4.8 Lpf) Water Closet
	3332004	CR-1005-A	Piston Kit – 1.0 gpf (3.8 Lpf) Urinal
	3332005	CR-1006-A	Piston Kit – 0.5 gpf (1.9 Lpf) Urinal
	3332017	CR-1015-A	Piston Kit – 0.25 gpf (1.0 Lpf) Urinal
	3332016	CR-1014-A	Piston Kit – 0.125 gpf (0.5 Lpf) Urinal

ALL PISTON KITS INCLUDE MAIN SEAT (see item 4 table to right) AND CR-124-A INSIDE COVER ASSEMBLY AS SHOWN IN ITEM 4. PISTON KIT COMPONENTS TABLE TO THE RIGHT.

Item

No.	Code No.	Part No.	Description
5A.	0302353	B-30-A	ADA-Compliant Handle Assembly CP
5B.	3302002	B-73-A	ADA-Compliant Handle Assembly CP
6A.	3332006	CR-1007	Handle Repair Kit
6B.	3302306	B-51-A	Handle Repair Kit
7.	5301139	A-31	Handle Gasket – 48/pkg
8.	0302389PK	B-74-A	Handle Grip Sub-Assembly ADA
9A.	0302309	B-56	Sleeve
9B.	0302109	B-7-A	CP Socket Assembly
10A.	0302354	B-53	Handle Socket
10B.	0301082PK	A-6	CP Handle Coupling
11.	3393004	V-600-AA	3/4" x 9" (19 x 229 mm) Vacuum Breaker - 6/pkg
	3393006	V-600-AA	1-1/4" x 9" (32 x 229 mm) Vacuum Breaker - 6/pkg
	3393007	V-600-AA	1-1/2" x 9" (38 x 229 mm) Vacuum Breaker - 6/pkg
12.	3323182	V-651-A	High Back Pressure Vacuum Breaker Repair Kit
13.	3332000	CR-1008-A	3/4" (19 mm) Spud Coupling Assembly
	3332001	CR-1009-A	1-1/4" (32 mm) Spud Coupling Assembly
	3332002	CR-1010-A	1-1/2" (38 mm) Spud Coupling Assembly
13A.	SEE SLIP JOINT GASKETS AND RINGS TABLE ON BOTTOM, PAGE 25		
14.	0308676PK	H-550	Stop Coupling
15.	0308801	H-551-A	Adjustable Tailpiece (2-1/16" (52 mm) long)
16A.	5308696	H-553	O-ring – 24/pkg
16B.	5308381	H-552	Locking Ring – 12/pkg
17.	0388000	H-700-A	1" Screwdriver Bak-Chek® Stop CP
	0388001	H-700-A	3/4" Screwdriver Bak-Chek® Stop CP
18.	3308853	H-541-ASD	Control Stop Repair Kit†
	3308856	H-543-ASD	Control Stop Repair Kit† for 3/4" Stops H-600, H-640
19.	0308612PK	H-622	CP Bonnet †
	0308843	H-577	CP Bonnet † – DISCONTINUED
20.	3308840	H-573-A	Locking Vandal Resistant Control Stop Cap includes H-573 Stop Cap CP and H-648 Friction Ring †
	0308848PK	H-582	Locking Vandal Resistant Control Stop Cap CP †
21.	3308651	H-651	Vandal Resistant Control Stop Cap Assembly †
22.	3308866	H-574	Control Stop Cap w/Bumper (-YO Variation) †
23.	3308867	H-576	Control Stop Cap w/Extended Bumper (-YG Variation)†
24.	3388017	H-1017	Flow Control (HEU Only) (Not Shown)
25.	5314243	CN-76	Cover Gasket (Pack of 12)
—	0305190	EL-190-A	Handle Adapter (manual only) for Optima® version

† For use w/H-700-A 1" & 3/4" and H-600-A 1" Screwdriver Bak-Chek® Control Stops.
‡ For use w/H-600-A 3/4" Screwdriver Bak-Chek® Control Stops.

ITEM 4. PISTON KIT COMPONENTS

Item	Code No.	Part No.	Description
A.	***	CR-124-A	Inside Cover Sub-Assembly
B.	***	***	Piston Cover
C.	5332095	CR-68-A	Molded Cup – 12/pkg
D.	5328019	SH-406	Spring – 12/pkg
E.	***	***	Relief Valve
F.	0307116	G-95	Relief Valve Seat
G.	***	***	Piston Body
H.	***	CR-125-A	Main Seat – 6/pkg (1.0 gpf)
	***	CR-170-A	Main Seat – 6/pkg (0.125 gpf, 0.25 gpf and 0.5 gpf)
I.	0307210	G-85	Filter O-ring
J.	0332124	CR-169	O-ring (for use with CR-125-A main seat ONLY)†
	5308958	H-589	O-ring* 6/pkg

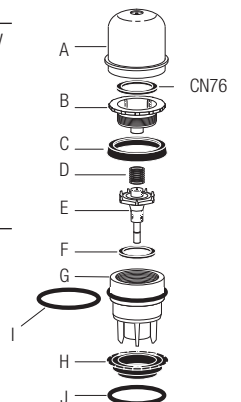

* Components are NOT interchangeable
*** Indicates component is NOT available separately

Crown® Flushometer

Crown® II (DISCONTINUED)

TROUBLESHOOTING GUIDE

IMPORTANT: The CROWN® flushometer is engineered for quiet operation. Excessive water flow creates noise, while too little water flow may not satisfy the needs of the fixture. Proper adjustment is made when plumbing fixture is cleansed after each flush without splashing water out from the lip AND a quiet flushing cycle is achieved.

Never open control stop to where the flow from the valve exceeds the flow capability of the fixture. In the event of a valve failure, the fixture must be able to accommodate a continuous flow from the valve.

ATTENTION INSTALLERS: With the exception of the control stop inlet, **DO NOT USE** pipe sealant or plumbing grease on any valve component or coupling! To protect the chrome or special finish of Sloan flushometers, **DO NOT USE** toothed tools to install or service these valves. Use our A-50 Super Wrench or other smooth-jawed wrench to secure couplings. Regulations for low consumption fixtures (1.6 gpf/6.0 Lpf closets and 1.0 gpf/3.8 Lpf urinals) prohibit use of higher flush volumes.

1. Valve DOES NOT function.

- A. Control stop or main valve is closed. Open control stop or main valve.
- B. Handle assembly is worn. Install Sloan handle repair kit, or replace handle.
- C. Relief valve is worn and sticking in UP position. Replace piston.

2. Insufficient volume of water to adequately siphon fixture.

- A. Control stop not open enough. Adjust control stop for desired delivery of water.
- B. Urinal piston parts inside a closet valve. Replace piston parts with proper closet piston.
- C. Low consumption valve installed on a non-low consumption fixture. Replace with proper flushometer. Crown® flushometers are not available with flush volume higher than 1.6 gpf/6.0 Lpf.
- D. Inadequate volume or pressure at supply. Increase water pressure or supply (flow) to valve. Consult factory for assistance.

3. Length of flush too short (short flushing) or valve closes off immediately.

- A. Piston assembly is not hand-tight. Screw the assembly hand-tight.
- B. Enlarged bypass orifice from corrosion or damage. Install NEW inside parts kit to correct problem and update flushometer.
- C. Urinal piston in closet flushometer. Replace piston with proper closet piston.
- D. Low consumption piston installed in non-low consumption fixture. Replace with proper flushometer. Crown® flushometers are not available with flush volume higher than 1.6 gpf (6.0 Lpf).
- E. Handle assembly worn. Install Sloan handle repair kit.

4. Length of flush too long (long flushing) or fails to close off.

- A. Piston is not seating properly or bypass orifice is clogged because of foreign material, or bypass orifice is clogged by an invisible gelatinous film from "over-treated" water. Disassemble the working parts and wash thoroughly. NOTE: Size of the orifice in the bypass is of utmost importance for the proper metering of water into the upper chamber of the valve. DO NOT enlarge or damage this orifice. Replace piston if cleaning does not correct problem.
- B. Line pressure has dropped and is not sufficient to force relief valve to seat. Shut off all control stops until pressure has been restored, then open them again.
- C. Main seat is fouled with debris or is worn. Clean or replace main seat.

5. Leaking at handle assembly.

- A. The B-85 seal may have deteriorated. Install new B-85 seal. NOTE: The B-85 seal will easily slide onto the bushing if it is wet.
- B. Handle gasket has been omitted. Install A-31 handle gasket or Sloan handle repair kit.
- C. Valve handle bushing is worn. Install Sloan handle repair kit.

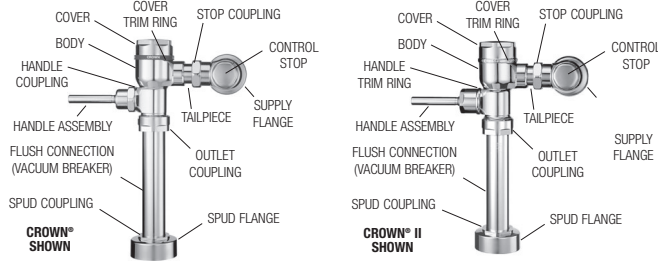

DISCONTINUED

CARE AND CLEANING

DO NOT USE abrasive or chemical cleaners (including chlorine bleach) to clean flushometers that may dull the luster and attack the chrome or special decorative finishes. Use **ONLY** mild soap and water, then wipe dry with clean cloth or towel.

While cleaning the bathroom tile, the flushometer should be protected from any splattering of cleaner. Acids and cleaning fluids will discolor or remove chrome plating.

Piston Identification Chart	Water Closet		Urinal			
	CR-1004-A	CR-1011-A	CR-1005-A	CR-1006-A	CR-1015-A	CR-1014-A
Piston Color	3332003	3332013	3332004	3332004	3332017	3332016
Cap Color	1.6 gpf (6.0 Lpf)	1.28 gpf (4.8 Lpf)	1.0 gpf (3.8 Lpf)	0.5 gpf (1.9 Lpf)	0.25 gpf (1.0 Lpf)	0.125 gpf (0.5 Lpf)
Stem Grooves						
Barrel (Large Ribs or Small Ribs)						
Cap Color	Green	Deep Purple	Yellow	Red	Burgundy	Pink
Piston Color	Green	Green	Clear	Burgundy	Burgundy	Burgundy
Barrel	Large Ribs	Large Ribs	Small Ribs	—	—	—
Seat Color	Green	Green	Black	Burgundy	Burgundy	Burgundy
Grooves	2	0	1	2	1	3

When assistance is required, please contact Sloan Technical Support at: 1-888-SLOAN-14 (1-888-756-2614).

Gem-2® Flushometer

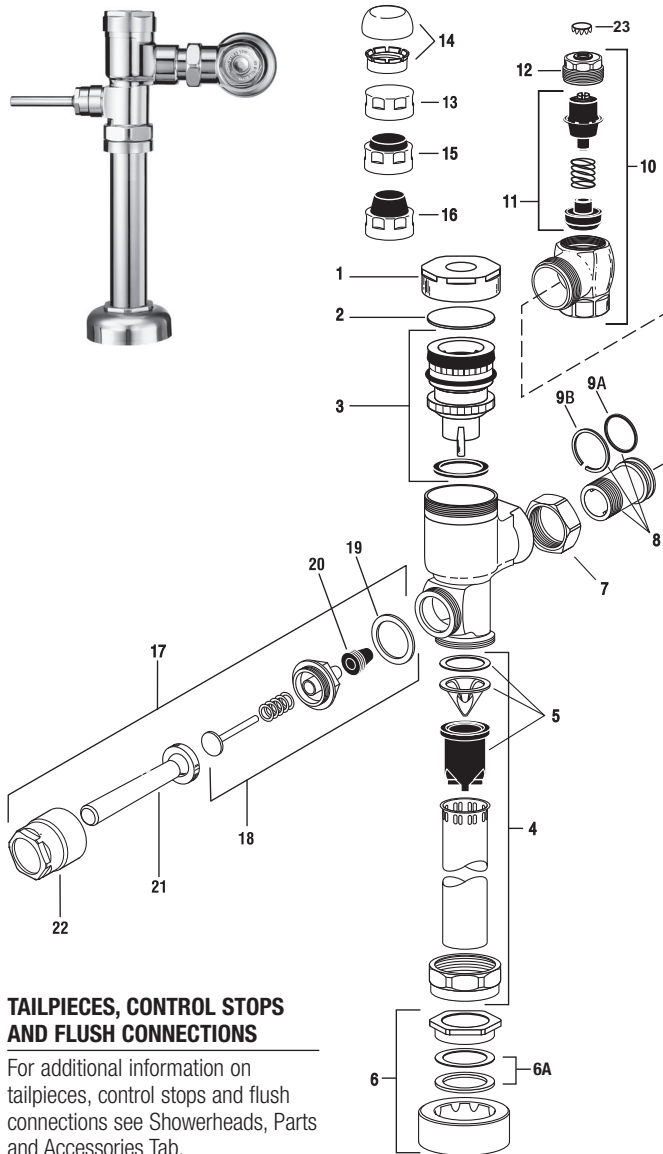

TAILPIECES, CONTROL STOPS AND FLUSH CONNECTIONS

For additional information on tailpieces, control stops and flush connections see Showerheads, Parts and Accessories Tab.

ITEM 6A. SLIP JOINT GASKETS AND RINGS

Size	Code No.	Part No.	Description
1-1/2"	5306058	F-3	Red Friction Ring
	5322001	VBF-5	Black Slip Joint Gasket
	5319086	S-30	Flexible Seat
	0319079	S-21	Rigid Seat (rubber over brass)
1-1/2" x 1-1/4"	0396062	F-105	Slip Joint Gasket – Rigid
1-1/4"	5306057	F-3	Red Friction Ring
	5322176	VBF-5	Black Slip Joint Gasket
	0307052/5307052	G-21	Rigid Seat (rubber over brass)
1"	5306056	F-3	Red Friction Ring
	5306115	F-5	Black Slip Joint Gasket
3/4"	5306055	F-3	Red Friction Ring
	5306113	F-5	Black Slip Joint Gasket

PARTS LIST

Item No.	Code No.	Part No.	Description
1.	0307142PK	G-105	CP Cover
2.	0307139	G-106	Slip Disc
3.	3307135	G-1022-A	Piston Kit – 1.28 gpf/4.8 Lpf Water Closet
	0307193	G-1007-A	Piston Kit – 3.5 gpf/13.2 Lpf Water Closet
	0307195	G-1016-A	Piston Kit – 1.6 gpf/6 Lpf Water Closet
	0307192	G-1009-A	Piston Kit – 1.5 gpf/5.7 Lpf Urinal
	0307185	G-1017-A	Piston Kit – 1.0 gpf/3.8 Lpf Urinal
	3307133	G-1018-A	Piston Kit – 0.5 gpf/1.9 Lpf Urinal
	3307134	G-1019-A	Piston Kit – 2.4 gpf/9.0 Lpf Water Closet
	3307136	G-1023-A	Piston Kit – 0.125 gpf/0.5 Lpf Urinal
	3307137	G-1024-A	Piston Kit – 0.25 gpf/1.0 Lpf Urinal

PISTON KITS FOR OLD STYLE ADJUSTABLE GEM FLUSHOMETERS

0307043	G-1003-A	Piston Kit – Water Closet
0307044	G-1002-A	Piston Kit – Urinal

ALL PISTON KITS INCLUDE G-21 MAIN SEAT (See next page)

4.	5323005	V-500-AA	3/4" x 9" Vacuum Breaker – 6 per package
	5323006	V-500-AA	1-1/4" x 9" Vacuum Breaker – 6 per package
	5323007	V-500-AA	1-1/2" x 9" Vacuum Breaker – 6 per package
5.	3323192	V-551-A	Vacuum Breaker Repair Kit
6.	3332002	CR-1010-A	1-1/2" (38 mm) Spud Coupling
	3332001	CR-1009-A	1-1/4" (32 mm) Spud Coupling
	3332000	CR-1008-A	3/4" (19 mm) Spud Coupling
6A.	SEE SLIP JOINT GASKETS AND RINGS TABLE BELOW LEFT		
7.	0308676PK	H-550	Stop Coupling
8.	0308801	H-551-A	Adjustable Tailpiece 2-1/16" (Standard Length)
9A.	5308696	H-553	O-ring – 24 per package
9B.	5308381	H-552	Locking ring – 12 per package
10.	3308876	H-790-A	1" Screwdriver Bak-Chek® Stop CP – complete
	3308875	H-790-A	3/4" Screwdriver Bak-Chek® Stop CP – complete
11.	3308853	H-541-A	Control Stop Repair Kit*
	3308856	H-543-A	Control Stop Repair Kit**
12.	0308612PK	H-622	CP Bonnet*
	0308843	H-577	CP Bonnet** – DISCONTINUED
13.	3308840	H-573-A	Control Stop Cap**
14.	3388017	H-1017	Flow Control (HEU Only) (Not Shown)
15.	3308866	H-574	Control Stop w/Bumper (-YO Variation)*
16.	3308867	H-576	Control Stop w/Extended Bumper (-YG Variation)*

HANDLE REPAIR KIT

17.	0307100	G-143	Handle Assembly
18.	5307074	G-50-A	Handle Repair Kit – 6 per package
19.	5307065	G-35	Handle Gasket – 48 per package
20.	5302297	B-39	Handle Seal – 12 per package
21.	0307024PK	G-145	Handle Grip
22.	0307020PK	G-144	Handle Socket
23.	5388002	H-528	Control Stop Plug CP* (12 per pack)

*For use with 1" and 3/4" H-700-A and 1" H-600-A Bak-Chek® screwdriver control stop
 **For use with 3/4" H-600-A Bak-Chek® screwdriver control stop

Gem-2® Flushometer

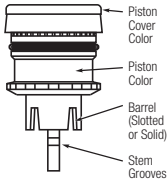

Gem-2 Pistons can be identified by the color, shape and marking of the above components.

ITEM 3. PISTON KITS

Code No.	Part No.	Description	Cover Color	Piston Color	Barrel	Grooves
0307193	G-1007-A	3.5 gpf (13.2 Lpf) – Water Closet	White	Gray	Slotted	2
0307195	G-1016-A	1.6 gpf (6.0 Lpf) – Water Closet	Green	Green*	Slotted	2
0307192	G-1009-A	1.5 gpf (5.7 Lpf) – Urinal	Black	Black	Solid	2
0307185	G-1017-A	1.0 gpf (3.8 Lpf) – Urinal	Yellow	Black	Solid	1
3307133	G-1018-A	0.5 gpf (1.8 Lpf) – Urinal	Red	Black	Solid	3
3307134	G-1019-A	2.4 gpf (9.0 Lpf) – Water Closet	Blue	Gray	Slotted	0
3307135	G-1022-A	1.28 gpf (4.8 Lpf) – Water Closet	Deep Purple	Tan*	Slotted	2
3307136	G-1023-A	0.125 gpf (0.5 Lpf) – Urinal	Pink	Burgundy	Solid	3
3307137	G-1024-A	0.25 gpf (0.9 Lpf) – Urinal	Burgundy	Burgundy	Solid	1

*Prior to February 2020 piston body color was black

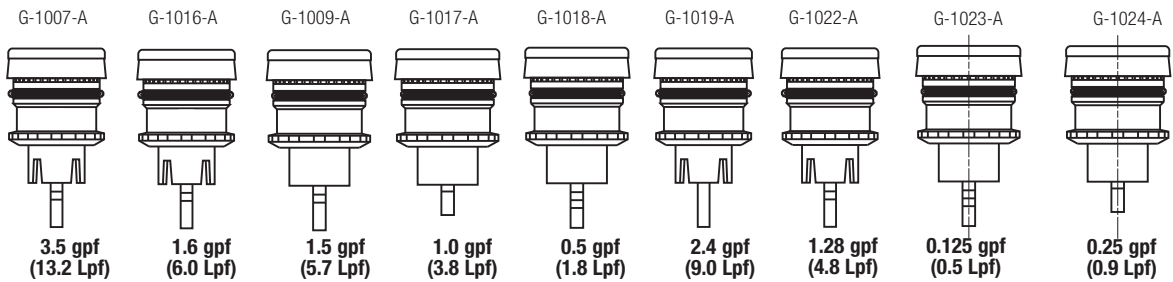

ITEM 3. PISTON COMPONENTS

Item	Code No.	Part No.	Description
A.	***	***	Piston Cover
B.	5307106	G-78	Molded Cup – 12 per package
C.	0307130	G-102	Spring
D.	***	***	Relief Valve
E.	0307116	G-95	Relief Valve Seat
F.	***	***	Piston Body
G.	0307210	G-85	Filter O-ring
H.	5307052	G-21	Main Seat – 6 per package

REPAIR KIT

Code No.	Part No.	Description
3307128	G-1011-A	Repair Kit includes Items: 2, B, C, E, G & H

For old style adjustable GEM flushometers use kit: G-1005-A
 *** Indicates component is NOT available separately

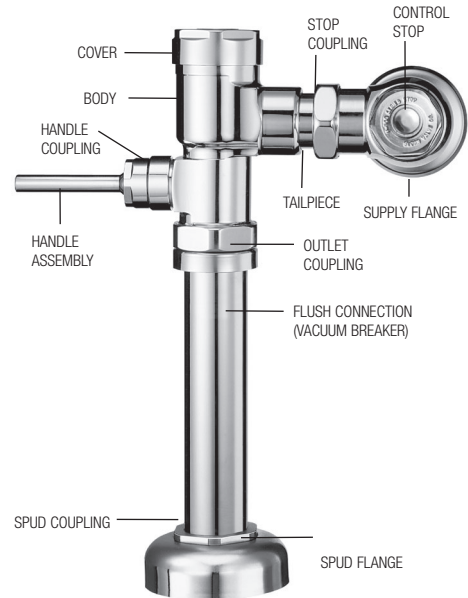
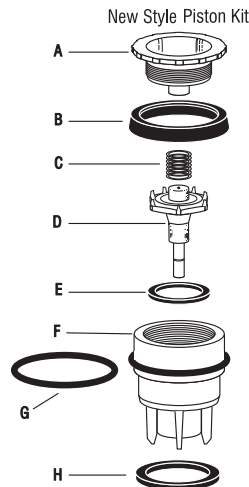

Gem-2® Flushometer

REPAIR PARTS FOR OLD STYLE GEM FLUSHOMETERS (PRE-1985) Adjustable Cover

Item			
No.	Code No.	Part No.	Description
1.	—	G-24	CP Cover Screw – DISCONTINUED
2.	—	G-23	CP Cover – DISCONTINUED
	—	G-26	CP Cover for Bumper – DISCONTINUED
3.	—	G-27	Bumper (12 per package) – DISCONTINUED
4.	0307058	G-25	Cover Gasket (12 per package)
5.	—	G-4	RB Inside Cover – DISCONTINUED
6.	—	G-6	RB Regular Screw – DISCONTINUED
7.	—	S-26	Packing DISCONTINUED
8.	—	S-24	Packing Disc DISCONTINUED
9.	—	G-10	RB Packing Nut – DISCONTINUED
10.	—	G-65	Gasket – DISCONTINUED
11.	—	G-5	Gasket DISCONTINUED

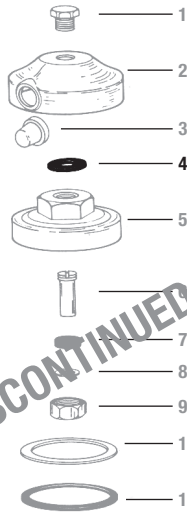

SPUD COUPLING FOR OLD STYLE GEM FLUSHOMETERS (PRE-MAY, 2003)

Item			
No.	Code No.	Part No.	Description
1.	0306125	F-5-AW	3/4" Spud Coupling
	0305140	F-5-AU	1-1/4" Spud Coupling
	0306146	F-5-AT	1-1/2" Spud Coupling
1A.	SEE SLIP JOINT GASKETS AND RINGS TABLE ON BOTTOM, PAGE 37		

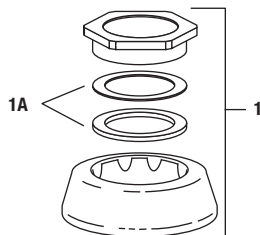

HANDLE ASSEMBLY FOR OLD STYLE GEM FLUSHOMETERS (PRE-MAY, 2003)

Item			
No.	Code No.	Part No.	Description
1.	0307100	G-143-A	Handle Assembly – 6 per package
2.	5307074	G-50-A	Handle Repair Kit – 6 per package
3.	5307065	G-35	Handle Gasket – 48 per package
4.	5302297	B-39	Handle Seal – (12 per package)
5.	G-36		Handle Grip
6.	G-28		Handle Socket

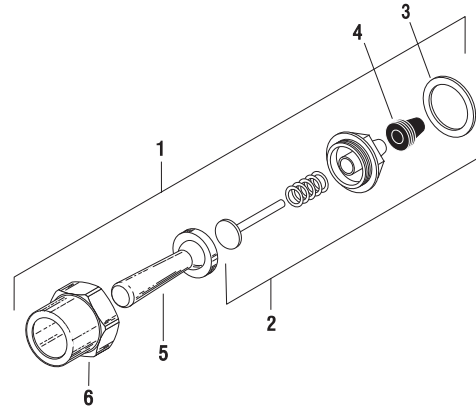

REPAIR PARTS FOR OLD STYLE PISTON

Item			
No.	Code No.	Part No.	Description
12.	0307105PK	G-77	Piston Cover
13.	5307106	G-78	Molded Cup* (12 per pack)
14.	0307113	G-84	Spring OBSOLETE
15.	0307110	G-81-A	Relief Valve
16.	0307112	G-83	Relief Valve Seat
17.	—	G-75	Closet Piston Body
	—	G-76	Urinal Piston Body
18.	0307052	G-21	Main Seat

* In addition must replace w/ G105 & G-106

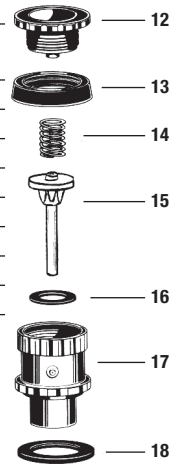

PISTON KITS FOR OLD STYLE ADJUSTABLE GEM VALVES

Code No.	Part No.	Description	Piston Color	Barrel	Grooves
0307044	G-1002-A	Urinal	Black	Solid	0
0307043	G-1003-A	Water Closet	Black	Slotted	0

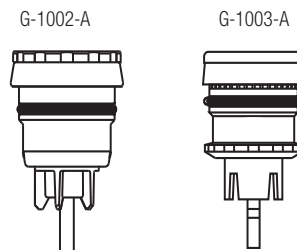

Gem-2® Flushometer

TROUBLESHOOTING GUIDE

IMPORTANT: The GEM flushometer is engineered for quiet operation. Excessive water flow creates noise, while too little water flow may not satisfy the needs of the fixture. Proper adjustment is made when plumbing fixture is cleansed after each flush without splashing water out from the lip AND a quiet flushing cycle is achieved.

Never open Control Stop to where the flow from the valve exceeds the flow capability of the fixture. In the event of a valve failure, the fixture must be able to accommodate a continuous flow from the valve.

ATTENTION INSTALLERS: With the exception of the control stop inlet, **DO NOT USE** pipe sealant or plumbing grease on any valve component or coupling! To protect the chrome or special finish of Sloan flushometers, **DO NOT USE** toothed tools to install or service these valves. Use our A-50 Super Wrench or other smooth-jawed wrench to secure couplings. Regulations for low consumption fixtures (1.6 gpf/6.0 Lpf closets and 1.0 gpf/3.8 Lpf urinals) prohibit use of higher flush volumes.

1. Valve DOES NOT function.

- A. Control stop or main valve is closed. Open control stop or main valve.
- B. Handle assembly is worn. Install handle repair kit G-50-A or replace handle.
- C. Relief valve is worn and sticking in UP position. Replace piston.

2. Insufficient volume of water to adequately siphon fixture.

- A. Control stop not open enough. Adjust control stop for desired delivery of water.
- B. Urinal piston parts inside a closet valve. Replace piston parts with proper closet piston.
- C. Low consumption valve installed on a non-low consumption fixture. Replace with proper piston kit.
- D. Inadequate volume or pressure at supply. Increase water pressure or supply (flow) to valve. Consult factory for assistance.

3. Length of flush too short (short flushing) or valve closes off immediately.

- A. Piston assembly is not hand-tight. Screw the assembly hand-tight.
- B. Enlarged bypass orifice from corrosion or damage. Install NEW inside parts kit to correct problem and update flushometer.
- C. Urinal piston in closet flushometer. Replace piston with proper closet piston.
- D. Low consumption piston installed in non-low consumption fixture. Replace with proper piston kit.
- E. Handle assembly worn. Install handle repair kit G-50-A.

4. Length of flush too long (long flushing) or fails to close off.

- A. Piston is not seating properly or bypass orifice is clogged because of foreign material, or bypass orifice is clogged by an invisible gelatinous film from "over-treated" water. Disassemble the working parts and wash thoroughly. **NOTE:** Size of the orifice in the bypass is of utmost importance for the proper metering of water into the upper chamber of the valve. **DO NOT** enlarge or damage this orifice. Replace piston if cleaning does not correct problem.
- B. Line pressure has dropped and is not sufficient to force relief valve to seat. Shut off all control stops until pressure has been restored, then open them again.
- C. 3.5 gpf closet piston has been used in a 1.0 or 1.5 gpf urinal or on a 1.6 gpf toilet. Replace with proper piston.
- D. G-21 main seat is fouled with debris or is worn. Clean or replace main seat.

5. Leaking at handle assembly.

- A. The B-39 seal may have deteriorated. Install new B-39 seal.
NOTE: The seal will easily slide right onto the bushing if it is wet.
- B. Handle gasket is missing. Install G-35 handle gasket or Sloan handle repair kit G-50-A.
- C. Valve handle bushing is worn. Install Sloan handle repair kit G-50-A.

CARE AND CLEANING

DO NOT USE abrasive or chemical cleaners to clean flushometers as they may dull the luster and attack the chrome or special decorative finishes. Use **ONLY** mild soap and water, then wipe dry with clean cloth or towel.

While cleaning the bathroom tile, the flushometer should be protected from any splattering of cleaner. Acids and cleaning fluids can discolor or remove chrome plating.

**When assistance is required, please contact
Sloan Technical Support at: 1-888-SLOAN-14 (1-888-756-2614).**

Naval® Flushometer

Also for use with Crown® (Old style),
Star and Marine

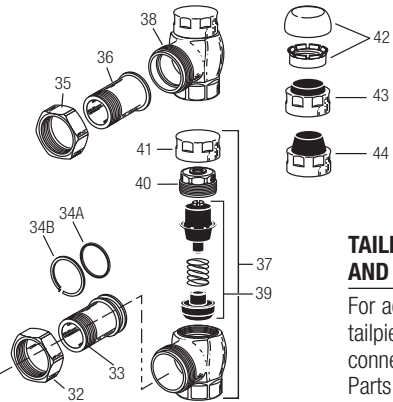
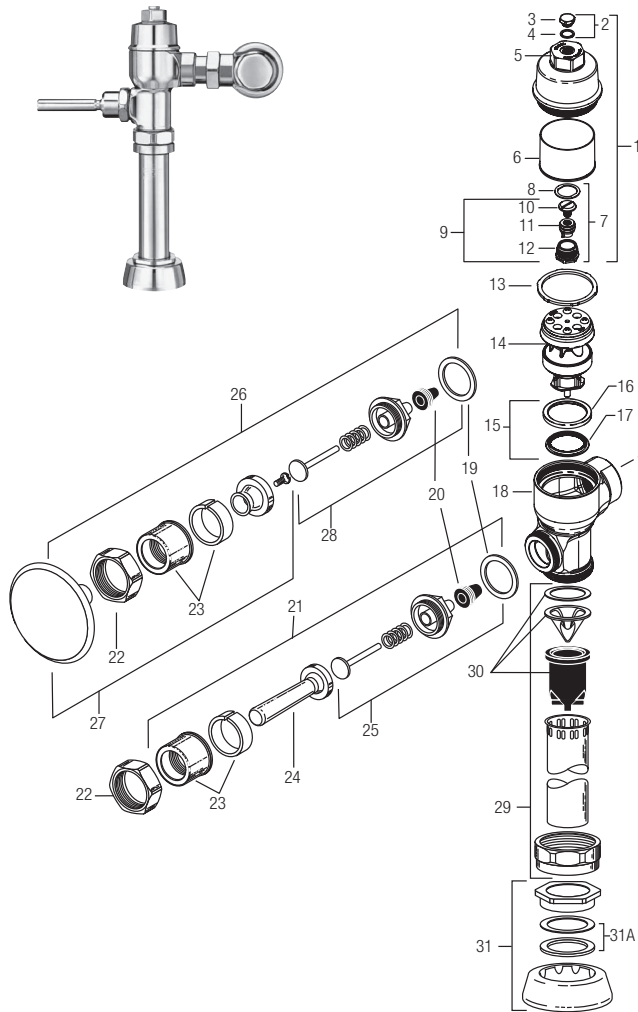

TAILPIECES, CONTROL STOPS, AND FLUSH CONNECTION'S

For additional information on tailpieces, control stops and flush connections see Showerhead's, Parts and Accessories Tab.

PARTS LIST

Item No.	Code No.	Part No.	Description
1.	0314229	CN-86-A	Cover Assembly CP
	0314310	CN-89-A	Cover Assembly CP One Pint* 1.6 gpf/6.0 Lpf, 1.0 gpf/3.8 Lpf
2.	5314010	CN-1007-A	Cap Screw Repair Kit – 6 per package
3.	—	CN-36	Cover Screw CP (included in item no.2)
4.	—	CN-30	Cover Screw Gasket (included in item no.2)
5.	—	CN-84	Cover (included in item no.1)
6.	—	CN-55	Cover Liner (included in item no.1)
7.	3314015	CN-1008-A	Regulating Screw Repair Kit**
8.	—	CN-81	Volume Adjustment Gasket (included in items no.1&7)
9.	0314315	CN-88-A	Low Consumption Volume Adjustment Sleeve Sub-Assembly 1.6 gpf/6.0 Lpf, 1.0 gpf/3.8 Lpf
10.	—	CN-80	Volume Adjustment Screw (included in items no.1&9)
11.	—	CN-78	Volume Adjustment Sleeve (included in item no.1)
	0314307	CN-87	Volume Adjustment Sleeve One Pint***
12.	0314301	CN-79	Volume Adjustment Housing
13.	5314243	CN-76	Cover Gasket – 12 per package
14.	0314016	CN-1002-A	Piston – Closet
	0314017	CN-1003-A	Piston – Urinal
15.	0314234PK	CN-21-A	Main Seat Assembly
16.	—	CN-111-A	Main Seat (included in items no.15)
17.	—	CN-113	Main Seat Ring (included in items no.15)
18.	0314020PK	CN-3	Body CP (less/Tailpiece)
19.	5301139	A-31	Handle Gasket – 48 per package

Item No.	Code No.	Part No.	Description
20.	5302297	B-39	Handle Seal – 12 per package
21.	3302002	B-73-A	Triple Seal Handicap Handle Assembly (ADA Compliant)
22.	0301082PK	A-6	Handle Coupling CP
23.	0302109	B-7-A	Socket Assembly CP
24.	0302389PK	B-74-A	Handicap Handle Grip CP (ADA Compliant)
25.	3302306	B-51-A	Triple Seal Handle Repair Kit – 1 per package
26.	0303351	C-42-A	3" Push Button Assembly CP
27.	3303347	C-1000-A	3" Push Button Replacement Kit
28.	3303396	C-64-A	3" Push Button Repair Kit
29.	5323005	V-500-AA	3/4" x 9" Vacuum Breaker
	5323006	V-500-AA	1-1/4" x 9" Vacuum Breaker
	5323007	V-500-AA	1-1/2" x 9" Vacuum Breaker
30.	3323192	V-551-A	Vacuum Breaker Repair Kit
31.	0306125	F-5-AW	3/4" Spud Coupling CP
	0306140	F-5-AU	1-1/4" Spud Coupling CP
	0306146	F-5-AT	1-1/2" Spud Coupling CP
31A.	SEE SLIP JOINT GASKETS AND RINGS TABLE ON BOTTOM, PAGE 43		
32.	0308676PK	H-550	Stop Coupling CP
33.	0314289	NH-551-A	Adjustable Tailpiece 2-1/16" CP
34A.	5308696	H-553	O-ring – 24 per package
34B.	5308381	H-552	Locking ring – 12 per package
35.	0308063PK	H-6	Ground Joint Stop Coupling CP
36.	0314028PK	NH-5	Ground Joint Tailpiece 1-5/8"
37.	0388022	H-710-A	1" Adjustable Tailpiece SD Bak-Chek® Control Stop CP
	0388025	H-710-A	3/4" Adjustable Tailpiece SD Bak-Chek® Control Stop CP
38.	0388024	H-710-AG	1" Ground Joint Screwdriver Bak-Chek® Control Stop CP
	0388026	H-710-AG	3/4" Ground Joint Screwdriver Bak-Chek® Control Stop CP
39.	3308853	H-541-A	Control Stop Repair Kit †
	3308856	H-543-A	Control Stop Repair Kit †
40.	0308612	H-622PK	Bonnet CP †
	0308843	H-577	Bonnet CP † – DISCONTINUED
41.	3308840	H-573	Control Stop Cap CP †
	0308848PK	H-582	Control Stop Cap CP †
42.	3308772	H-1010-A	Vandal Resistant Stop Cap Assembly †
	3308790	H-1009-A	Vandal Resistant Stop Cap Assembly †
43.	3308866	H-574	Control Stop Cap with Bumper† (YO Variation)
44.	3308867	H-576	Control Stop Cap with Extended Bumper† (YG Variation)

* Use CN-89-A Cover Assembly One-Pint for reduced flush volumes 1.6 gpf/6.0 Lpf, 1.0 gpf/3.8 Lpf
 ** CN-1008-A Regulating Screw Repair Kit contains the parts shown plus the parts for old style adjusting screw as currently shown on the repair guide (CN-24, CN-25, CN-26, CN-61)
 *** Use CN-87 Volume Adjustment Sleeve One-Pint for reduced flush volumes
 † For use with 1" and 3/4" H-740-A-CP (less cap) and 1" H-540-A-CP (w/H-37 cap) Bak-Chek® screwdriver control stops
 ‡ For use with 3/4" H-600 Series Bak-Chek® screwdriver control stops

Naval® Flushometer

Also for use with Crown® (Old style),
Star and Marine

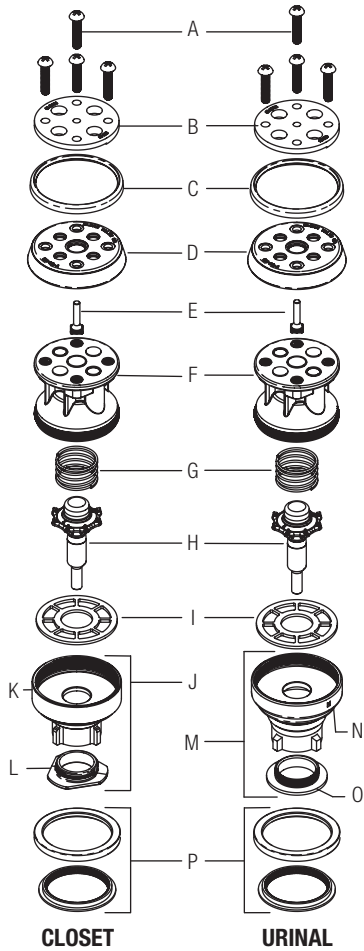

NAVAL PISTON COMPONENTS (Items 14 thru 17 on previous page)

Item	Code No.	Part No.	Description
A.	5314200	CN-17	Top Plate Screws – 24 per package
B.	0314082PK	CN-15	Top Plate
	0314179PK	CN-15-A	Top Plate – Shower Valve only
C.	0314314	CN-92	Support Cup Lip Seal
			Part of CN-1015-A (3314003)
D.	5314188	CN-68-A	Single Lip Cup – 12 per package
E.	0314204PK	CN-57	Xpelor
F.	0314228	CN-160	Piston Body
G.	5328019	SH-406	Spring – 12 per package (Replaces S/CN-58 Safety Bar)
H.	0314078	CN-18-A	Relief Valve
I.	5314226	CN-120	Relief Valve Seat – 12 per package
J.	0314240	CN-123-AC	Guide Assembly – Closet
K.	0314231	CN-23	Guide – Closet
L.	0314237	CN-144	Restriction Ring – Closet (included in item J)
M.	0314242	CN-123-AU	Guide Assembly – Urinal
N.	0314189	CN-43	RC Guide – Urinal (included in item M)
O.	—	CN-45	NK Restriction Ring – Urinal (included in item M)
P.	0314234PK	CN-21-A	Main Seat
	0314223PK	CN-121-A	Main Seat – Shower Valve only

NOTE: Naval® pistons can be used to replace pistons in older Crown® and Star flushometers.

REPAIR KITS

Code No.	Part No.	Description
0314016	CN-1002-A	Piston with Main Seat – Closet
0314017	CN-1003-A	Piston with Main Seat – Urinal
5314094	CN-1004-A	Piston Rebuild Kit – Closet & Urinal – 6 per package includes: 13, A, B, C, D, E, I, K, Cap Screw Gasket & Regulating Screw Packing
5314184	CN-1006-A	Piston Rebuild Kit – Shower – 6 per package includes: 13, A, B, C, D, E, I, K, Cap Screw Gasket & Regulating Screw Packing
3314015	CN-1008-A	Regulating Screw Repair Kit – includes: 2, 8, 9, CN-24 Packing Disc, CN-25 Packing Gland, CN-26 Packing Regulating Screw, CN-61 Screw Regulating Stable Piston
0314191	CN-1009-A	Piston with Main Seat – Shower
5314050	CN-1010-A	Crown®/Naval® Valve Washer Set – 6 per package includes: 13, 19, 20, C, D, I, K, Cap Screw Gasket & Regulating Screw Packing
5319049	S-14-AA	Double Cup Repair Kit (Old style Crown, Star and Marine)
5319046	S-14-A	Double Cup Lip Seal only (Old style Crown, Star and Marine)

NOTE: Older Crown® pistons need S-14-A W/CN-1002, 1003 & 1009 if replacing piston.

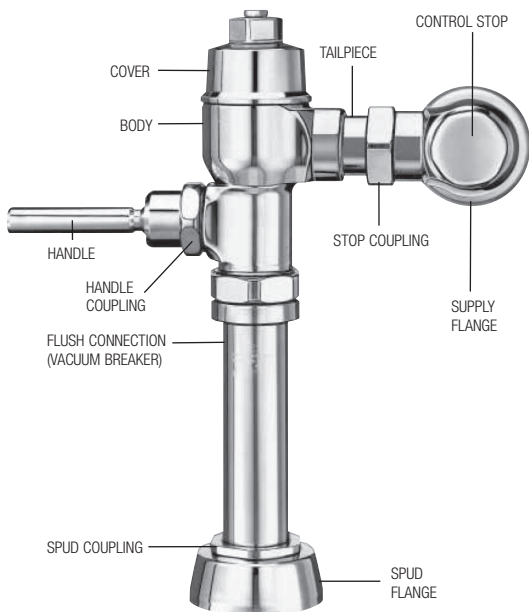

ITEM 31A. SLIP JOINT GASKETS AND RINGS

Size	Code No.	Part No.	Description
1-1/2"	5306058	F-3	Red Friction Ring
	5322001	VBF-5	Black Slip Joint Gasket
	5319086	S-30	Flexible Seat
	0319079	S-21	Rigid Seat (rubber over brass)
1-1/2" x 1-1/4"	0396062	F-105	Slip Joint Gasket – Rigid
1-1/4"	5306057	F-3	Red Friction Ring
	5322176	VBF-5	Black Slip Joint Gasket
	0307052/5307052	G-21	Rigid Seat (rubber over brass)
1"	5306056	F-3	Red Friction Ring
	5306115	F-5	Black Slip Joint Gasket
3/4"	5306055	F-3	Red Friction Ring
	5306113	F-5	Black Slip Joint Gasket

Naval® Flushometer

Also for use with Crown® (Old style),
Star and Marine

TROUBLESHOOTING GUIDE

IMPORTANT: The NAVAL® flushometer is engineered for quiet operation. Excessive water flow creates noise, while too little water flow may not satisfy the needs of the fixture. Proper adjustment is made when plumbing fixture is cleansed after each flush without splashing water out from the lip AND a quiet flushing cycle is achieved.

Never open Control Stop to where the flow from the valve exceeds the flow capability of the fixture. In the event of a valve failure, the fixture must be able to accommodate a continuous flow from the valve.

ATTENTION INSTALLERS: With the exception of the control stop inlet, DO NOT USE pipe sealant or plumbing grease on any valve component or coupling! To protect the chrome or special finish of Sloan flushometers, DO NOT USE toothed tools to install or service these valves. Use our A-50 Super-Wrench™ or other smooth-jawed wrench to secure couplings. Regulations for low consumption fixtures (1.6 gpf/6.0 Lpf closets and 1.0 gpf/3.8 Lpf urinals) prohibit use of higher flush volumes.

NOTE: In all piston variations the SH-406 spring has replaced the "U" bar. In all piston variations the CN-68-A single lip cup has replaced the S-14-A double lip cup. When rebuilding a piston, install the CN-68-A single lip cup with the cup facing down.

1. Valve DOES NOT function.

- A. Control stop or main valve closed. Open control stop or main valve.
- B. Handle assembly is worn. Install handle repair kit B-51-A or replace handle.

2. Insufficient volume of water to adequately siphon fixture.

- A. Control stop not open enough. Adjust control stop for desired delivery of water.
- B. Urinal or shower piston installed in a closet valve or older blow out urinal. Replace piston with proper closet piston (see item 4).
- C. Regulating screw (on top of valve) not at proper setting. Turn regulating screw counterclockwise to increase flush. Adjustment range: urinal – 0.5 to 3 gpf (1.9 to 11.4 Lpf); closet – 1.5 to 7 gpf (5.7 to 26.5 Lpf).
- D. Piston worn out. Repair or replace piston.
- E. Inadequate volume or pressure at supply. If no gauges are available to properly measure supply pressure or volume of water at the valve, then completely remove the entire piston from the valve, reassemble cover and open control stop to allow water to pass through empty valve. If the supply is adequate to siphon the fixture, remove the flow ring from the bottom of the piston to provide additional flow. If the supply is not adequate to siphon the fixture, steps should be taken to increase the pressure and/or supply.

3. Length of flush too short (short flushing) or valve closes off immediately.

- A. Regulating screw not at a proper setting. Turn regulating screw counterclockwise to lengthen flush.
- B. Water passing by damaged or worn piston cup. Repair or replace piston.
- C. Loose piston assembly or loose top plate screw. Tighten top plate screws. Screw piston body and guide together (hand tighten ONLY – rubber relief valve seat will distort if screwed too tight).
- D. Damaged or worn piston top plate or expelor. Repair or replace piston.
- E. Urinal or shower piston installed in a closet valve or older blow out urinal. Replace piston with closet piston CN-1002-A.

4. Length of flush too long (long flushing) or fails to close off.

- A. Regulating screw not at proper setting. Turn regulating screw clockwise to shorten flush.
- B. Relief valve in piston is not seating properly due to wear or debris. Disassemble piston assembly and wash under running water. Repair or replace piston if necessary.
- C. Bypass holes in piston or top plate clogged or fouled with debris. Disassemble piston assembly and wash under running water. Repair or replace piston if necessary.
- D. Closet piston installed in urinal valve. Replace piston with urinal piston CN-1003-A.
- E. Line water pressure has dropped and is not sufficient to force relief valve to seat. Shut off control stop until pressure has been restored, then reopen stop.

5. Water splashes from fixture.

- A. Supply volume is more than necessary. Adjust control stop to meet flow rate required for proper cleansing of fixture.
- B. Lime or mineral accumulation on fixture vortex or spreader holes. Remove lime or mineral build-up in fixture.

6. Flush is not considered "quiet" or makes noise at close off.

- A. Control stop not properly adjusted. Adjust control stop to meet flow rate required for proper cleansing of the fixture.
- B. Worn, damaged or loose main seat. Replace main seat.
- C. Worn piston. Repair or replace piston.

7. Leaking at handle assembly.

- A. The B-39 handle seal may be deteriorated. Install new B-39 handle seal. NOTE: The B-39 seal will easily slide right onto the bushing if it is wet.
- B. Handle gasket has been omitted. Install A-31 handle gasket or handle repair kit B-51-A.
- C. Valve handle bushing is worn. Install handle repair kit B-51-A.

CARE AND CLEANING INSTRUCTIONS

DO NOT USE abrasive or chemical cleaners to clean flushometers that may dull the luster and attack the chrome or special decorative finishes. Use **ONLY** mild soap and water, then wipe dry with clean cloth or towel.

While cleaning the bathroom tile, protect the flushometer from any splattering of cleaner. Acids and cleaning fluids can discolor or remove chrome plating.

When assistance is required, please contact

Sloan Technical Support at: 1-888-SLOAN-14 (1-888-756-2614).

TruFlush Flushometer

Not available in USA or Canada

Manual Closet Flushometers

- TRF 156 - 1.6 gpf
- TRF 156 - 1.28 gpf
- TRF 156 - 1.1 gpf

Manual Urinal Flushometers

- TRF 196 - 0.5 gpf
- TRF 196 - 0.25 gpf
- TRF 196 - 0.125 gpf

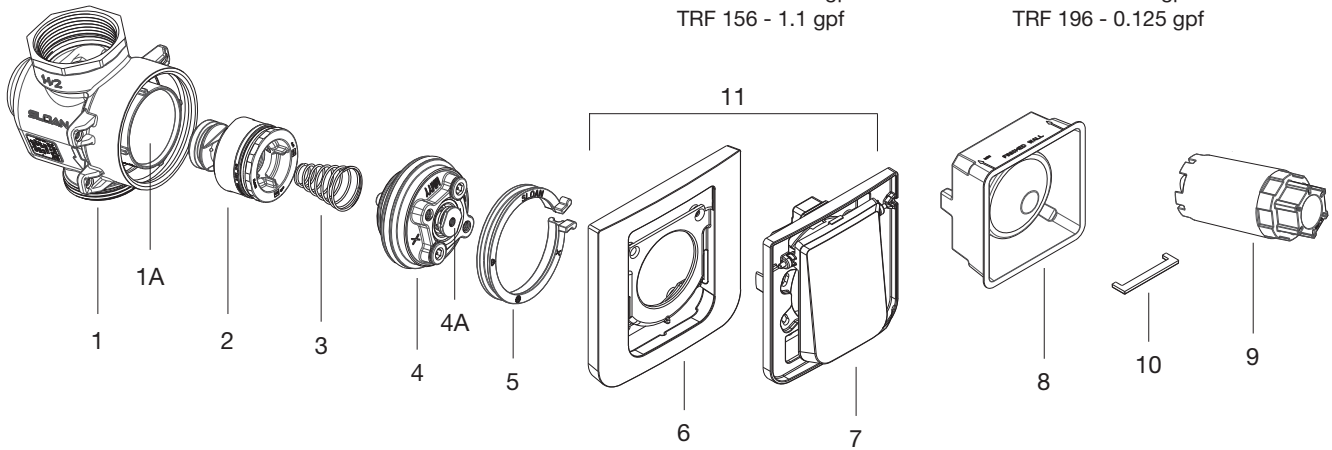

PARTS LIST			
Item No.	Code No.	Part No.	Description
1.	—	—	Valve Assembly
1A.	0340081	GBL-63-A	Shut Off Sleeve (with O-Ring)
2.	See table to the right	—	Piston Assembly with Spring
3.	—	—	Conical Spring*
4.	See table on next page	—	Activation Assembly
4A.	3340018	GBL-1018-A	Plunger Assembly
5.	3340011	GBL-1011-A	Safety Collar
6.	—	—	TRF Manual Finished Wall Plate, CP
7.	—	—	TRF Manual Wall Bracket with Button Assembly
8.	33400034	GBL-1061-A	Replacement Kit, Mud Guard Manual (4 Pack)
9.	3340012	GBL-1012-A	Activation Assembly Tool
10.	0340094	GBL-75	Depth Guide Tool
11.	—	GBL-200-A	TRF Manual Wall Bracket and Button Assembly Includes items 6 & 7.

* Included with Piston Assembly. † Consult factory for finish options.

ITEM NO. 2 - MANUAL PISTON ASSEMBLY SELECTION GUIDE			
Code No.	Part No.	Description	Piston Color*
3340024	GBL-1024-A	1.6 gpf/6.0 Lpf Closet Piston Assembly (Washdown)	Orange
3340005	GBL-1005-A	1.6 gpf/6.0 Lpf Closet Piston Assembly	Green
3340006	GBL-1006-A	1.28 gpf/4.8 Lpf Closet Piston Assembly	Purple/Black
33400064	GBL-1089-A	1.1 gpf/4.2 Lpf Closet Piston Assembly	Grey/Black
3340007	GBL-1007-A	0.5 gpf/1.9 Lpf Urinal Piston Assembly	Red
3340008	GBL-1008-A	0.25 gpf/1.0 Lpf Urinal Piston Assembly	Burgundy
3340009	GBL-1009-A	0.125 gpf/0.48 Lpf Urinal Piston Assembly	Pink

* Colors may differ. Consult factory to confirm you have the correct Piston Assembly.

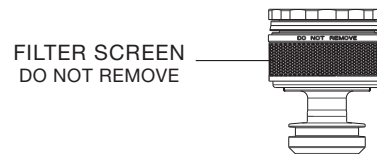

TRUFLUSH MANUAL PISTON
SEE CHART BELOW FOR MORE

ITEM NO. 2 - MANUAL PISTON IDENTIFICATION CHART

Flush Volume	1.6 gpf WD (India) Water Closet	1.6 gpf Water Closet	1.28 gpf Water Closet	1.1 gpf Water Closet	0.5 gpf Urinal	0.25 gpf Urinal	0.125 gpf Urinal
Piston Body	Orange with Screen	Green with Screen	Purple with Screen	Grey with Screen	Red with Screen	Burgundy with Screen	Pink with Screen
Flow Control	Orange	Green	Black Cage	Black Cage	Red	Burgundy	Pink
Part Number	GBL-1024-A	GBL-1005-A	GBL-1006-A	GBL-1089-A	GBL-1007-A	GBL-1008-A	GBL-1009-A
Code Number	3340024	3340005	3340006	33400064	3340007	3340008	3340009

ITEM NO. 4 - MANUAL ACTIVATION ASSEMBLY SELECTION GUIDE			
Code No.	Part No.	Description	Aspirator Retainer Color*
3340026	GBL-1026-A	1.6 gpf/6.0 Lpf Closet Activation Assembly (Washdown)	Orange
3340000	GBL-1000-A	1.6 gpf/6.0 Lpf Closet Activation Assembly	Green
3340001	GBL-1001-A	1.28 gpf/4.8 Lpf Closet Activation Assembly	Purple
3340063	GBL-1093-A	1.1 gpf/4.2 Lpf Closet Activation Assembly	Grey/Black
3340002	GBL-1002-A	0.5 gpf/1.9 Lpf Urinal Activation Assembly	Red
3340003	GBL-1003-A	0.25 gpf/1.0 Lpf Urinal Activation Assembly	Burgundy
3340004	GBL-1004-A	0.125 gpf/0.48 Lpf Urinal Activation Assembly	Pink

ASPIRATOR SELECTION GUIDE			
Code No.	Part No.	Description	Aspirator Retainer Color*
3340032	GBL-1032-A	1.6 gpf/6.0 Lpf Closet Aspirator Assembly (Washdown)	Orange
3340028	GBL-1028-A	1.6 gpf/6.0 Lpf Closet Aspirator Assembly	Green
3340030	GBL-1030-A	1.28 gpf/4.8 Lpf Closet Aspirator Assembly	Purple
3340058	GBL-1095-A	1.1 gpf/4.2 Lpf Closet Aspirator Assembly	Grey
3340031	GBL-1031-A	0.5 gpf/1.9 Lpf Urinal Aspirator Assembly	Red
3340029	GBL-1029-A	0.25 gpf/1.0 Lpf Urinal Aspirator Assembly	Burgundy
3340042	GBL-1033-A	0.125 gpf/0.48 Lpf Urinal Aspirator Assembly	Pink

* Colors may differ. Consult factory to confirm you have the correct Aspirator.

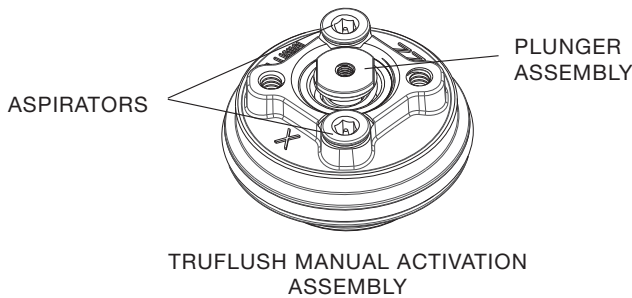

IMPORTANT NOTE FOR 1.1 GPF FLUSHOMETERS & REPLACEMENT KITS

Sloan 1.1 gpf/4.2 Lpf ultra-high efficiency flushometers meets all applicable standards and requirements. However, with low flush volumes it is imperative that they only be used in conjunction with toilet fixtures and drain line systems designed to operate with adequate flow rates and volumes in order to effectively eliminate waste and move it out of the building. It is the responsibility of the user to ensure both of these conditions are met. Not doing so may void your warranty.

Sloan 1.1 gpf diaphragm and piston kits are designed as a replacement part for Sloan 1.1 gpf/4.2 Lpf flushometers only. They are not intended to be used as a means to reduce water consumption in flushometers with higher flush volumes such as 1.28 gpf/4.8 Lpf or 1.6 gpf/6.0 Lpf or higher. Using this kit in any manner other than with a Sloan 1.1 gpf flushometer may void your warranty.

TROUBLESHOOTING GUIDE

1. Flushometer Does Not Function (No Water/Flush).

- A. Ensure water supply to Valve is turned on.
- B. Shut Off Sleeve is in closed position. Turn counter-clockwise to open water flow. **Note:** there is approximately 1/8-turn (45°) of free spinning as the Activation Assembly engages the Shut Off Sleeve between opening and closing the Valve.
- C. Plunger screw is not adjusted properly. Adjust screw using depth guide tool.

2. Volume Of Water Is Not Sufficient To Evacuate The Bowl.

- A. Plunger screw is not adjusted properly (short button engagement of plunger). Adjust screw using depth guide tool.
- B. Insufficient flow pressure. Readjust Activation Assembly by turning counter-clockwise to increase flow pressure.
- C. Water supply pressure is inadequate (low). Increase the water supply pressure. Contact the fixture manufacturer for minimum water supply requirements of the fixture.
- D. Wrong model installed; i.e., 0.5 gpf/1.9 Lpf urinal installed on a 1.6 gpf/6.0 Lpf closet fixture. Replace with proper model.
- E. Check lip seal for wear. Replace Piston if lip seal is worn or twisted.

3. Too Much Water To Fixture.

- A. Excessive flow pressure. Readjust Activation Assembly by turning clockwise to decrease flow pressure.
- B. Long Flush. Worn Piston; replace with new proper gpf/Lpf Piston.
- C. Wrong model installed; i.e., 1.6 gpf/6.0 Lpf model installed on 0.5 gpf/1.9 Lpf or 0.25 gpf/1.0 Lpf urinal fixture. Replace with proper model per guide.

4. Valve Does Not Shut Off.

- A. Plunger screw is not adjusted properly (constant contact on plunger). Adjust screw using depth guide tool.
- B. Supply line water pressure has dropped and is not sufficient to close the Valve. Close Activation Assembly until pressure is restored.
- C. Piston Filter Screen is clogged, Piston is damaged, or large debris stuck behind Piston. Turn off water at Shut Off Sleeve, release pressure, remove Safety Collar and Activation Assembly. Remove Piston and check inside Valve for large debris. **Do not attempt to remove Piston filter screen.** Replace Piston if damaged or cleaning does not correct the problem.

5. Leaking at Plunger.

- A. Seal worn. Replace Activation Assembly.

6. Chirping Noise Is Heard At Start Or End Of Flush.

- A. Caused by air purging from the system inside the Valve Assembly. Noise will subside with several flushes or within a day.

7. Valve Leaks Through Aspirator When Activated.

- A. Debris between the umbrella Valve and the Retainer. Blow air on the Aspirator. If this does not correct the problem, remove Retainer with 5 mm Allen Key (not included) and wash it under clean running water. Replace Aspirator if cleaning does not correct the problem.
- B. Loose Retainer. Hand tighten Retainer with 5 mm Allen key (not included). Do not overtighten. Replace Aspirator if this does not correct the problem.

CARE AND CLEANING

DO NOT USE abrasive or chemical cleaners (including chlorine bleach) to clean Flushometers that may dull the luster and attack the chrome or special decorative finishes. Use **ONLY** mild soap and water, then wipe dry with a clean cloth or towel. If using a cleaner in a spray bottle, **DO NOT** spray directly onto the Flushometer, instead spray cleaner into a clean cloth and then wipe down the Flushometer.

While cleaning bathroom tile, protect the Flushometer from any splattering of cleaner. Acids and abrasive cleaning fluids will discolor or remove chrome plating.

When assistance is required, please contact Sloan Technical Support at 1.888.SLOAN.14 (1.888.756.2614).

Sloan CX Manual Flushometer

Manual Closet Flushometers

- CX 158 - 1.6 gpf (Wall Hung)
- CX 158 - 1.28 gpf (Wall Hung)
- CX 158 - 1.1 gpf (Wall Hung)
- CX 154 - 1.6 gpf (Floor Mount)
- CX 154 - 1.28 gpf (Floor Mount)
- CX 154 - 1.1 gpf (Floor Mount)

Manual Urinal Flushometers

- CX 198 - 0.5 gpf
- CX 198 - 0.25 gpf
- CX 198 - 0.125 gpf

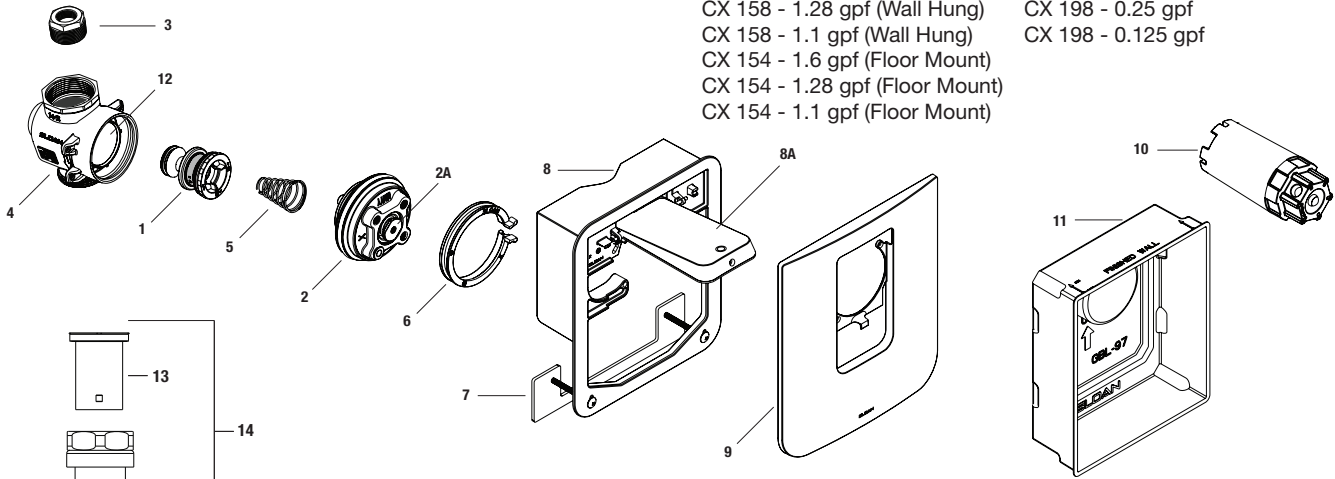

For Model 158, Wall Hung

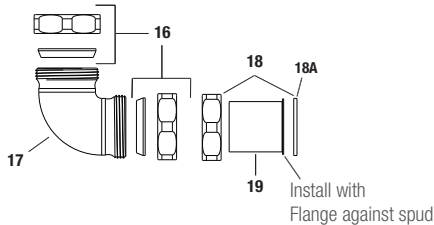

For Model 198, Urinals

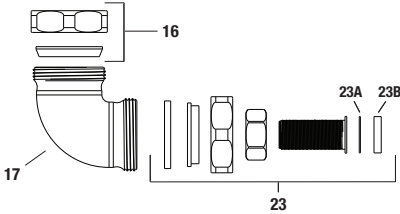

For Model 154, Floor Mount Exposed Rear Inlet

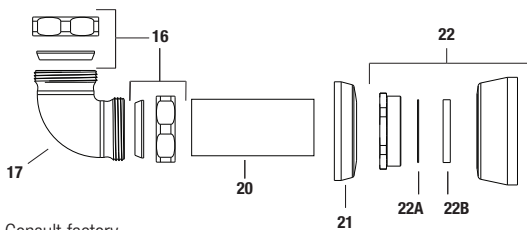

* Consult factory

** Consult factory for alternate finish options

The information contained in this document is subject to change without notice.

PARTS LIST			
Item No.	Code No.	Part No.	Description
1.	See table on next page		Piston Assembly
2.	See table on next page		Activation Assembly
2A.	3340018	GBL-1018-A	Manual Plunger Assembly Repair Kit
3.	0340062	GBL-56	Inlet Adapter 1-1/2" NPT x 1" NPT Closet
	0340063	GBL-171	Inlet Adapter 1-1/2" NPT x 3/4" NPT Urinal
4.	—	—	Valve Body*
5.	—	—	Conical Spring**
6.	3340011	GBL-1011-A	Safety Collar (Collar for Bonnet)
7.	33400011	GBL-214-A	C-Bracket Kit with Screws
8.	—	—	Manual CX Wall Bracket*
8A.	See table on next page		Manual CX Button Only
9.	See table on next page		Manual CX Finished Wall Plate
10.	03340012	GBL-1012-A	Activation Assembly Tool
11.	33400033	GBL-1060-A	Manual CX Mud Guard (4 pack)
12.	0340085	GBL-66-A	Shut Off Sleeve (with O-Ring)
* Not sold separately. ** Included with Piston			
FLUSH CONNECTION PARTS			
Item No.	Code No.	Part No.	Description
13.	3323182	V-651	Vacuum Breaker Kit
14.	0323011	V-500-A	RB Vacuum Breaker Assembly
15.	33060011	F-227-A	Adjustable Tube 6.5" Replacement Kit, 158, 198
	33060012	F-228-A	Adjustable Tube 10.5" Replacement Kit, 154
16.	0306395	F-211-A	CX Poly Washer and Coupling (set of 2)
17.	0306392PK	F-305	CX Elbow for CX Poly Washer
18.	0306091	F-2-A	1-1/2" Coupling with S-21 Gasket
18A.	0319079	S-21	Rigid Gasket
19.	0306031PK	F-1	1-1/2" x 6" Tube
20.	0396119PK	F-101	CP Tube Outlet 1-1/2" x 10-1/2"
21.	0306237PK	F-7	Tube Flange 1-1/2" x 2-3/4" with Prongs

Sloan CX Manual Flushometer

FLUSH CONNECTION PARTS CONTINUED

Item No.	Code No.	Part No.	Description
22	0306146PK	F-5-A	1-1/2" Spud Coupling Assembly CP*
22A	5306058	F-3	Friction Ring 1-1/2"
22B	5322001	VBF-5	Slip Joint Gasket 1-1/2"
23	0306396	—	CX Urinal Flush Connection Kit
23A	5306055	F-3	Red Friction Ring 3/4"
23B	5306113	F-5	Gasket 3/4"

ITEM NO. 1 - MANUAL PISTON ASSEMBLY SELECTION GUIDE

Code No.	Part No.	Description	Piston Color*
3340053	GBL-1037-A	1.6 gpf/6.0 Lpf Closet Piston Assembly	Green
3340054	GBL-1038-A	1.28 gpf/4.8 Lpf Closet Piston Assembly	Purple/Black
33400059	GBL-1087-A	1.1 gpf/4.2 Lpf Closet Piston Assembly	Grey/Black
3340055	GBL-1039-A	0.5 gpf/1.9 Lpf Urinal Piston Assembly	Red
3340056	GBL-1040-A	0.25 gpf/1.0 Lpf Urinal Piston Assembly	Burgundy
33400004	—	0.125 gpf/0.48 Lpf Urinal Piston Assembly†	Pink

* Colors may differ. Consult factory to confirm you have the correct assembly. † 0.125 gpf/0.48 Lpf Valve Components (Piston, Main Seat, and Activation Assembly) are NOT interchangeable with any other flush volume Valves.

IMPORTANT NOTE FOR 1.1 GPF FLUSHOMETERS & REPLACEMENT KITS

Sloan 1.1 gpf/4.2 Lpf ultra-high efficiency flushometers meets all applicable standards and requirements. However, with low flush volumes it is imperative that they only be used in conjunction with toilet fixtures and drain line systems designed to operate with adequate flow rates and volumes in order to effectively eliminate waste and move it out of the building. It is the responsibility of the user to ensure both of these conditions are met. Not doing so may void your warranty.

Sloan 1.1 gpf diaphragm and piston kits are designed as a replacement part for Sloan 1.1 gpf/4.2 Lpf flushometers only. They are not intended to be used as a means to reduce water consumption in flushometers with higher flush volumes such as 1.28 gpf/4.8 Lpf or 1.6 gpf/6.0 Lpf or higher. Using this kit in any manner other than with a Sloan 1.1 gpf flushometer may void your warranty.

ITEM NO. 1 - MANUAL PISTON IDENTIFICATION CHART

Flush Volume	1.6 gpf Water Closet	1.28 gpf Water Closet	1.1 gpf Water Closet	0.5 gpf Urinal	0.25 gpf Urinal	0.125 gpf Urinal
Piston Body	Green	Purple	Grey	Red	Burgundy	Pink
Flow Control	Green	Black Cage	Black Cage	Red	Burgundy	Pink
Part Number	GBL-1037-A	GBL-1038-A	GBL-1087-A	GBL-1039-A	GBL-1040-A	—
Code Number	3340053	3340054	33400059	3340055	3340056	33400004

ITEM NO. 2 - ACTIVATION ASSEMBLY SELECTION GUIDE

Code No.	Part No.	Description	Plug Color*
3340048	GBL-1033-A	1.6 gpf/6.0 Lpf Closet Activation Assembly	Green
3340049	GBL-1034-A	1.28 gpf/4.8 Lpf Closet Activation Assembly	Purple
33400057	GBL-1091-A	1.1 gpf/4.2 Lpf Closet Activation Assembly	Grey
3340051	GBL-1035-A	0.5 gpf/1.9 Lpf Urinal Activation Assembly	Red
3340052	GBL-1036-A	0.25 gpf/1.0 Lpf Urinal Activation Assembly	Burgundy
33400005	—	0.125 gpf/0.48 Lpf Urinal Activation Assembly	N/A; Nickel plated brass

* Colors may differ. Consult factory to confirm you have the correct Activation Assembly.

† 0.125 gpf/0.48 Lpf Valve Components (Piston, Main Seat, and Activation Assembly) are NOT interchangeable with any other flush volume Valves.

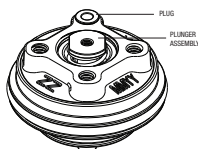

ADDITIONAL PARTS

Code No.	Part No.	Description
—	F-304	Poly Washer 1-1/2" (Only available in F-211-A, Item 16)
33400008	GBL-212-A	Plunger Screw Kit (screws, wrench, nut, and gauge)
33400012	GBL-215-A	Manual Wall Bracket Mounting Screws (Wall Bracket to Valve, Finished Plate to Wall Bracket)
33400014	GBL-1045-A	Manual CX Finished Wall Plate and Button Assembly, SF†
33400015	GBL-1046-A	Manual CX Finished Wall Plate and Button Assembly, CP†
33400016	GBL-1047-A	Manual CX Finished Wall Plate and Button Assembly, BN†
33400017	GBL-1048-A	Manual CX Finished Wall Plate and Button Assembly, PB†
33400018	GBL-1049-A	Manual CX Finished Wall Plate and Button Assembly, GR†
33400039	GBL-1064-A	Manual CX Button Only Replacement Kit, SF
33400041	GBL-1065-A	Manual CX Button Only Replacement Kit, CP
33400042	GBL-1066-A	Manual CX Button Only Replacement Kit, BN
33400043	GBL-1067-A	Manual CX Button Only Replacement Kit, PB
33400044	GBL-1068-A	Manual CX Button Only Replacement Kit, GR

† Includes mounting screws and wrench.

Sloan CX Manual Flushometer

TROUBLESHOOTING GUIDE

1. Flushometer Does Not Function (No Water/Flush).

- A. Ensure water supply to Valve is turned on.
- B. Shut Off Sleeve is in closed position. Turn counter-clockwise to open water flow. **Note:** there is approximately 1/8-turn (45°) of free spinning as the Activation Assembly engages the Shut Off Sleeve between opening and closing the Valve.
- C. Plunger screw is not adjusted properly. Adjust screw using depth guide.

2. Volume Of Water Is Not Sufficient To Evacuate The Bowl.

- A. Plunger screw is not adjusted properly (short button engagement of plunger). Adjust screw using depth guide tool.
- B. Insufficient flow pressure. Readjust Activation Assembly by turning counter-clockwise to increase flow pressure.
- C. Water supply pressure is inadequate (low). Increase the water supply pressure. Contact the fixture manufacturer for minimum water supply requirements of the fixture.
- D. Wrong model installed; i.e., 0.5 gpf/1.9 Lpf urinal installed on a 1.6 gpf/6.0 Lpf closet fixture. Replace with proper model.
- E. Check lip seal for wear. Replace Piston if lip seal is worn or twisted.

3. Too Much Water To Fixture.

- A. Excessive flow pressure. Readjust Activation Assembly by turning clockwise to decrease flow pressure.
- B. Long Flush. Worn Piston; replace with new proper gpf/Lpf Piston.
- C. Wrong model installed; i.e., 1.6 gpf/6.0 Lpf model installed on 0.5 gpf/1.9 Lpf or 0.25 gpf/1.0 Lpf urinal fixture. Replace with proper model per guide.

4. Valve Does Not Shut Off.

- A. Plunger screw is not adjusted properly (constant contact on plunger). Adjust screw using depth guide tool.
- B. Supply line water pressure has dropped and is not sufficient to close the valve. Close Activation Assembly until pressure is restored.
- C. Piston Bypass is clogged, Piston is damaged, or large debris stuck behind Piston. Turn off water at Shut Off Sleeve, release pressure, remove Safety Collar and Activation Assembly. Remove Piston and check inside Valve for large debris. Replace Piston if damaged or cleaning does not correct the problem.

5. Leaking at Plunger.

- A. Seal worn. Replace Activation Assembly.

6. Chirping Noise Is Heard At Start Or End Of Flush.

- A. Caused by air purging from the system inside the Valve Assembly. Noise will subside with several flushes or within a day.

CARE AND CLEANING

DO NOT USE abrasive or chemical cleaners (including chlorine bleach) to clean Flushometers that may dull the luster and attack the chrome or special decorative finishes. Use mild soap and water, then wipe dry with a clean soft cloth or towel. If using a cleaner in a spray bottle, **DO NOT** spray directly onto the Flushometer, instead spray cleaner into a clean cloth and then wipe down the Flushometer.

While cleaning surrounding bathroom tile, protect the Flushometer from any splattering of cleaner. Acids and abrasive cleaning fluids will discolor or remove chrome plating.

When assistance is required, please contact Sloan Technical Support at 1.888.SLOAN.14 (1.888.756-2614).

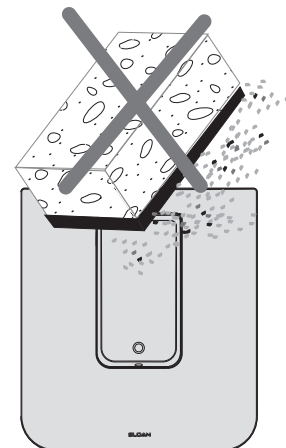

Dolphin® Flushometer

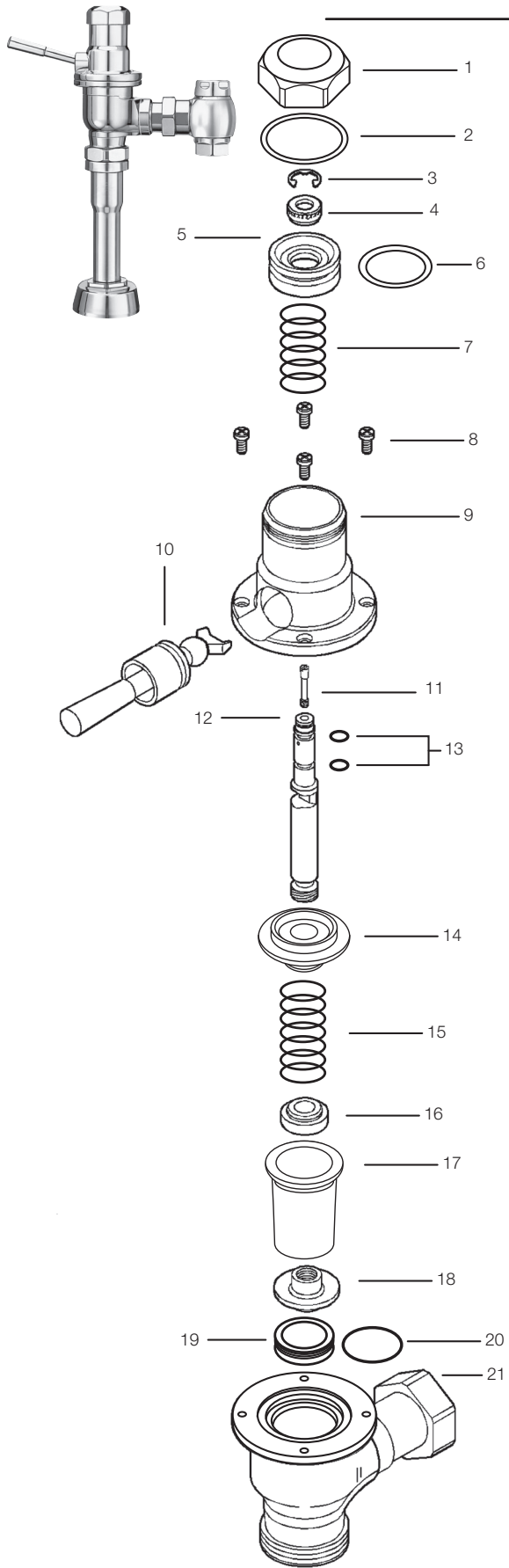

PARTS LIST—DOLPHIN® FLUSHOMETER

Item No.	Code No.	Part No.	Description
1.	0337007	DO-1	Cover Nut CP
2.	5337125	DO-2	O-ring-Seat – 1 required – 6 per package (Cover Gasket)
3.	5337129	DO-28	Retaining Ring – 1 required – 24 per package
4.	5337006	DO-4	Stem Nut RB – 1 required – 6 per package
5.	0337004PK	DO-5	Piston
6.	5337075	DO-6	O-ring-Piston – 1 required – 6 per package
7.	5337039	DO-7	Piston Spring – 1 required – 6 per package
8.	5337011	DO-11	Cover Screw CP – 4 required – 24 per package
9.	0337003PK	DO-10	Upper Body CP
10.	0337042	DO-20	Handle and Socket Assembly CP
	0337012	DO-26	Socket
11.	5337126	DO-3	Regulating Screw RB – 1 required – 6 per package
12.	0337087PK	DO-9	Stem RB
13.	0328336	SH-75	O-ring-Throttle Seal (2 required)(included in repair Kits see table below)
14.	0337005PK	DO-14	Bushing RB
15.	0337009PK	DO-16	Compression Spring (Main Spring)
16.	5337034	DO-17	Insert RB – 1 required – 6 per package
17.	0337018	DO-15	“Flex-Sac”
18.	0337084	DO-18	Seating Nut. Part of DO-32 “Flex-Sac” Assembly (See below)
19.	0337016	DO-19	Seat Assembly w/O-ring
20.	0337086PK	DO-22	O-ring
21.	0337031PK	DO-13-NC	Lower Body CP-Closet
	0337032PK	DO-13-NU	Lower Body CP-Urinal
22.	—	DO-90-AA	Complete Body Assembly
	—	DO-90-AAG	Complete Body Assembly
	—	DO-90-AAU	Complete Body Assembly

REPLACEMENT AND REPAIR KITS

A.	0337044	DO-1000-A	Piston w/ o-ring. Component parts: Items 5 and 6
B.	3337035	DO-1001-A	Repair Kit-Dolphin Handle Component parts: Items 10, 11, 12, and 13
C.	0337134	DO-32	Flex-Sac Assembly Component parts: Items 17 and 18
D.	0337136	DO-32-AA	Repair Kit-“Flex-Sac” Assembly. Component parts: Items 2, 6, 13, 17, and 18
E.	0337137	DO-32-AAN	Repair Kit-“Flex-Sac” and Stem. Component parts: Items 2, 6, 7, 13, 15, 17, 18, 19, and 20
F.	0337036	DO-19-A	Seat Assembly w/ o-ring Component parts: Items 19 and 20
G.	0337030	DO-12-A	Upper Body Assembly. Component parts: Items 1 through 7 and 9 through 18
H.	0337031PK	DO-13-A-NC	Lower Body Assembly for Closet. Component parts: Item 21 Lower Body, Coupling (CP), and Ground Joint Tail (CP)

Dolphin® Flushometer

PARTS LIST—DOLPHIN® FLUSHOMETER MODELS AND VARIATIONS

Item No.	Code No.	Part No.	Description
1.	0337023	DO-90-AAGNC	Closet Valve Body and Handle Assembly —Dolphin Type I
	0337025	DO-90-AAGNU	Urinal Valve Body and Handle Assembly —Dolphin Type II
2A.	0388025	H-710-A	Bak-Chek® Control Stop CP with ¾" NPTF Inlet for Adjustable Tail
	0388022	H-710-A	Bak-Chek® Control Stop CP with 1" NPTF Inlet for Adjustable Tail
2B.	0388048	NH-710-AG	Bak-Chek® Control Stop w/ ¾" NPTF Inlet for Ground Joint Tail (Naval Brass; use w/ Shipboard flushometer Models Type II Class A and B; requires A-35 Reducer Bushing)
	0388058	NH-710-AG	Bak-Chek® Control Stop w/ 1" NPTF Inlet for Ground Joint Tail (Naval Brass)
	0388044	NH-710-AGS	Bak-Chek® Control Stop w/ 1" NPSM Inlet for Ground Joint Tail (Naval Brass; use w/ Shipboard flushometer Models Type I and II when Sil-Braze Adapter is used)
3.	0306196PK		F-7 1" (25 mm) Supply Flange CP (Supplied When Valve is NOT Ordered w/ Sweat Solder Kit)
	0306191PK	F-7	¾" (19 mm) Supply Flange CP (Supplied When Valve is NOT Ordered w/ Sweat Solder Kit)
4.	3308782	H-633-AA	1" (25 mm) Sweat Solder Kit with Cast Set Screw Flange CP ("–YBYC" Variation)
	3308788	H-636-AA	¾" (19 mm) Sweat Solder Kit with Cast Set Screw Flange CP ("–YBYC" Variation)
5A.	0323013	V-500-AA	1-½" (38 mm) x 10-½" (267 mm) Vacuum Breaker Assembly CP (Model 110/111)
	0323019	V-500-AA	1-½" (38 mm) x 23" (534 mm) Vacuum Breaker Assembly CP (Model 115)
5B1.	0396119PK	F-101	1-½" (38 mm) x 10-1/2" (267 mm) Outlet Tube CP Type I Class B
5B2.	0306093	F-2-AT	Coupling CP w/ S-30 gasket
5C1.†	0314004PK	NF-1	1-½" (38 mm) Scored Outlet CP (Shipboard Model, Type I, Class A)
5C2.‡	0306092	F-2-A	Coupling CP w/ S-30 gasket
5D1.	5323010	V-500-A	1-½" (38 mm) Vacuum Breaker Assembly CP (6 Pack) (Model 120 does not include F-2-A Coupling, see Item 5D2 below)
5D2.	0306092	F-2-A	Coupling CP w/ S-30 gasket
5E.†	0306850	NF-29-A	Outlet Tube Assembly ¾" (19 mm) x 6-½" (165 mm) Scored Outlet w/ ½" Offset (Shipboard Model, Type II, Class A)
5F.	0306849	NF-29-A	¾" (19 mm) x 6-½" (165 mm) Flush Connection with ½" Offset and ¾" x ½" Reducer for ½" Spud (Shipboard Model, Type II, Class B)
5G.‡	0323004	V-500-AA	¾" (19 mm) x 10-½" (267 mm) Vacuum Breaker Assembly CP (Model 186)
5H.†	0306780	F-29-A	¾" (19 mm) x 10-½" (267 mm) Flush Connection CP (Model 186–XYW)
6.†	0396302PK	F-109	1-½" (38 mm) Flush Connection CP
7.	SEE SLIP JOINT GASKETS AND RINGS TABLE ON BOTTOM, PAGE 15		
7A.	0306146	F-5-AT	1-½" (38 mm) Spud Coupling Assembly (Models 110/111, 115, 120)
7B.	0306125	F-5-AW	¾" (19 mm) Spud Coupling Assembly (Model 186)
8.	0306982PK	F-40	½" (13 mm) Sil-Braze Adapter

‡ Cut to proper length at installation. Allow a minimum of 5" (127 mm) between tube ends when using rubber hose for shock mounted equipment.

† This Outlet Tube is available in various lengths. Consult factory for assistance.

IMPORTANT NOTES

With the exception of the control stop inlet, DO NOT USE pipe sealant or plumbing grease on any valve component or coupling!

Protect the chrome or special finish of Sloan flushometers — DO NOT USE toothed tools to install or service these valves.

Use a A-50 Super-Wrench™ or smooth jawed spud wrench to secure all couplings.

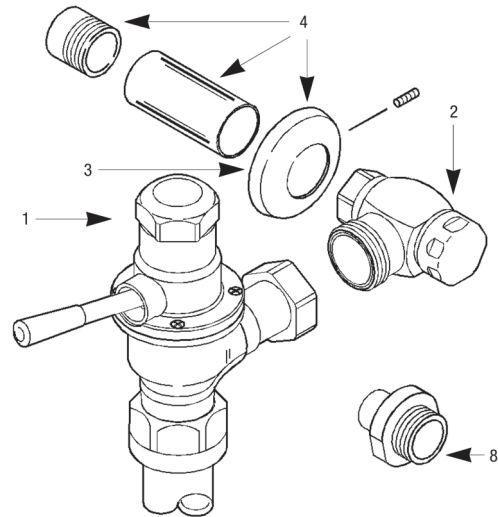

Models 110/111, 115 Shipboard Model

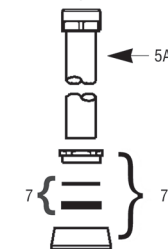

Models 110-XYV, 111-XYV, and Type I, Class B

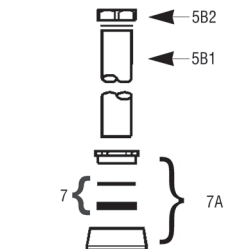

Shipboard Model, Type I, Class A

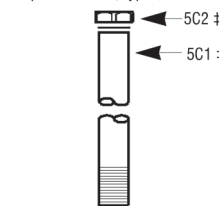

Model 120

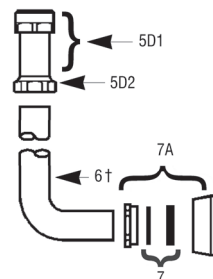

Shipboard Model, Type II, Class A

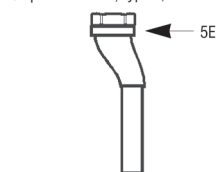

Shipboard Model, Type II, Class B

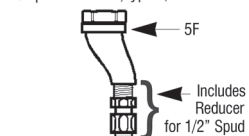

Model 186

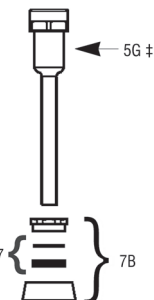

Model 186-XYW

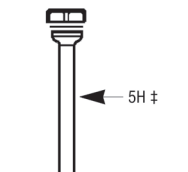

Dolphin® Flushometer

PARTS LIST—DOLPHIN® FLUSHOMETER MODELS AND VARIATIONS

Size	Code No.	Part No.	Description
ITEM 7. Slip Joint Gaskets and Rings			
1-1/2"	5306058	F-3	Red Friction Ring
	5322001	VBF-5	Black Slip Joint Gasket
	5319086	S-30	Flexible Seat
	0319079	S-21	Rigid Seat (rubber over brass)
1-1/2" x 1-1/4"	0396062	F-105	Slip Joint Gasket – Rigid
1-1/4"	5306057	F-3	Red Friction Ring
	5322176	VBF-5	Black Slip Joint Gasket
	0307052/5307052	G-21	Rigid Seat (rubber over brass)
1"	5306056	F-3	Red Friction Ring
	5306115	F-5	Black Slip Joint Gasket
3/4"	5306055	F-3	Red Friction Ring
	5306113	F-5	Black Slip Joint Gasket

TROUBLESHOOTING GUIDE

1. Flushometer DOES NOT function.

- A. Control stop or main valve is closed. Open control stop or main valve.
- B. Handle socket assembly is damaged. Replace DO-20 handle socket assembly.

2. Volume of water is inadequate to siphon fixture.

- A. Control stop is not open enough. Adjust control stop for desired delivery of water volume.
- B. Timing of flushometer closure is set too fast. Remove DO-1 cover nut. Use a small blade screwdriver to turn DO-3 regulating screw clockwise.
- C. Water supply volume or pressure is inadequate. If no gauges are available to properly measure supply pressure or volume, completely open control stop and hold down flushometer handle without allowing it to close. If fixture siphons, increase timing of closure (see previous solution). If fixture does not siphon, steps must be taken to increase the supply pressure and/or volume. Contact fixture manufacturer for minimum water supply requirements of fixture.

3. Flushometer closes immediately.

- A. Oil chamber of upper body is empty. Remove DO-1 cover nut. Fill oil chamber with SAE 10 Oil.
- B. Piston seal is worn or damaged. Replace DO-6 piston O-ring seal.

4. Length of flush is too short (short flushing).

- A. Volume of oil in oil chamber of upper body is low. Remove DO-1 cover nut. Fill oil chamber with SAE 10 oil.
- B. Timing of flushometer closure is not adequately adjusted. Remove DO-1 cover nut. Using small blade screwdriver, turn DO-3 regulating screw clockwise until a satisfactory flush is achieved.

5. Length of flush is too long (long flushing).

- A. Timing of flushometer closure not adequately adjusted. Remove DO-1 cover nut. Using small blade screwdriver, turn DO-3 regulating screw counterclockwise until a satisfactory flush is achieved.

6. Oil is leaking from handle.

- A. Stem seals are worn or damaged. Replace two (2) SH-75 throttle seal O-rings.

7. Valve DOES NOT close completely (water trickle).

- A. Compression spring is worn or damaged. Replace DO-16 compression spring.
- B. Flex-sac assembly is worn. Replace DO-15 flex-sac.

CARE AND CLEANING INSTRUCTIONS

DO NOT USE abrasive or chemical cleaners to clean flushometers, they may dull the luster and attack the chrome finish. Use **ONLY** mild soap and water, and then wipe dry with a clean towel or cloth.

When cleaning, protect the exposed flushometer from any splattering of cleaner. Acids and cleaning fluids can discolor or remove chrome plating.

When assistance is required, please contact

Sloan Technical Support at: 1-888-SLOAN-14 (1-888-756-2614).

Slimline® Bedpan Washer Flushometer

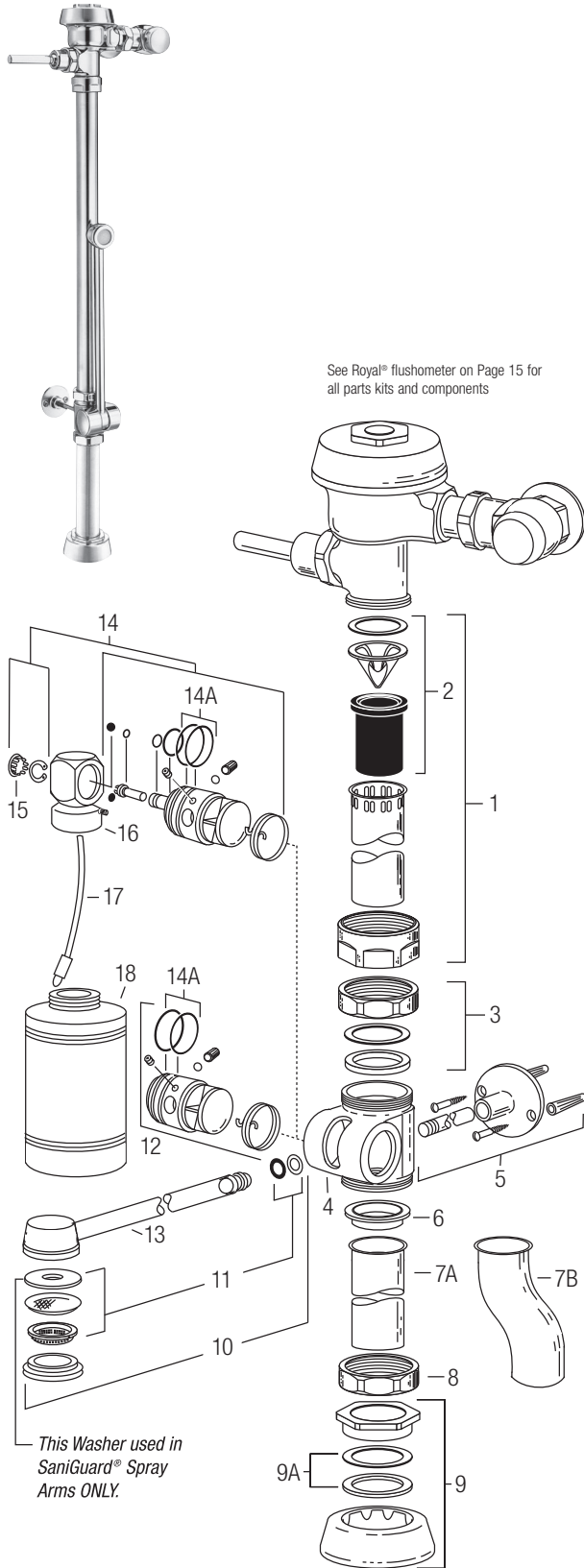

PARTS LIST

Item No.	Code No.	Part No.	Description
1.	0393009	V-600-AA	1-1/2" x 21-1/2" CP Vacuum Breaker
	0393008	V-600-AA	1-1/2" x 13-1/2" CP Vacuum Breaker (ADA height)
	0393029	V-600-AA	1-1/2" x 21-1/2" CP Vacuum Breaker w/2" Offset
2.	3323182	V-651-A	Vacuum Breaker Repair Kit
3.	0306093	F-2-A	1-1/2" Slip Joint Coupling
4.	0309001PK	DV-1	Diverter Valve Body (non-Deoseptic bottle)
	0309052	DV-17	Diverter Valve Body (Deoseptic bottle)
5.	3309035	DV-1001-A	Wall Support Kit
6.	0309027	F-1003	Outlet Tube Gasket – for Flanged Tubes only
7A.	0309029PK	F-1005	Outlet Tube (1-1/2" x 7-3/4")
7B.	0396525PK	F-182	Outlet Tube (1-1/2" x 8" w/ 1-1/2" offset)
8.	0306045	F-2	1-1/2" Coupling Nut
9.	0306146	F-5-AT	1-1/2" Spud Coupling Assembly
9A.	SEE SLIP JOINT GASKETS AND RINGS TABLE ON BOTTOM, PAGE 15		
10.	3309044	DV-32-AA	12" Spray Arm Replacement Kit
	3309077	DV-1014-A	Short Spray Arm Replacement Kit (for use with F-182 Offset Outlet Tube)
11.	3309032	DV-1007-A	Spray Arm Repair Kit
12.	3309037	DV-1003-A	Pivot Replacement Kit
—	0309021	DV-55-A	Diverter Valve Assembly and 12" Spray Arm Assembly includes: 3, 4, 8, 10, 12
—	0309022	DV-69-A	Diverter Valve Assembly and 10" Spray Arm Assembly includes: 3, 4, 8, 10, 12
13.	3309015	DV-1017-A	Repair Kit 15" Sanigard® Spray Arm (.625-18 UNF-2A Thread)

DEOSEPTIC UNIT PARTS

Item No.	Code No.	Part No.	Description
14.	3309036	DV-1002-A	Deoseptic Pivot Replacement Kit
14A.	5337075PK	D0-6	O-ring-Piston – 2 required – 6 per package
14B.	0309004PK	DV-4	Set Screw (#10-32 x 3/8")
14C.	0309016PK	DV-16	Diverter Valve Seal Washer
14D.	0309014PK	DV-14	Diverter Valve Seal
15.	0309024PK	DV-21	Plug Button
16.	0309033	DV-33-A	Swivel & ball check Assembly
17.	0309036	DV-36-A	Aspirator Tube Assembly
18.	0309018	DV-29	Deoseptic Solution Bottle

BEDPAN WASHER REBUILD KITS

Code No.	Part No.	Description
5309031	DV-50-A	Diverter Rebuild Kit Includes Outlet Tube Gasket (Item 6), Spray Arm Repair Kit (Item 11), and all Items in Pivot Replacement Kit (Item 12) except Pivot.
3309040	DV-1004-A	Deoseptic Diverter Rebuild Kit Includes Outlet Tube Gasket (Item 6), Spray Arm Repair Kit (Item 11), and all Items in Pivot Replacement Kit (Item 13) except Pivot.

To convert a standard diverter assembly to a deoseptic diverter assembly use:

3309048	DV-1005-A	Deoseptic Conversion Kit
----------------	-----------	--------------------------

SANIGUARD® HANDLE ASSEMBLY

Code No.	Part No.	Description
0302330	B-73-A-SG	Handle Assembly CP (ADA complaint) with Sani-Guard

Slimline® Bedpan Washer Flushometer

ITEM 9A. SLIP JOINT GASKETS AND RINGS

Size	Code No.	Part No.	Description
1-1/2"	5306058	F-3	Red Friction Ring
	5322001	VBF-5	Black Slip Joint Gasket
	5319086	S-30	Flexible Seat
	0319079	S-21	Rigid Seat (rubber over brass)
1-1/2" x 1-1/4"	0396062	F-105	Slip Joint Gasket – Rigid
1-1/4"	5306057	F-3	Red Friction Ring
	5322176	VBF-5	Black Slip Joint Gasket
	0307052/5307052	G-21	Rigid Seat (rubber over brass)
1"	5306056	F-3	Red Friction Ring
	5306115	F-5	Black Slip Joint Gasket
3/4"	5306055	F-3	Red Friction Ring
	5306113	F-5	Black Slip Joint Gasket

SLIMLINE® BEDPAN WASHER RETROFIT DIVERTERS

Code No.	Part No.	Description
3309049	DV-100-R	CP Diverter Valve Assembly
3309022	DV-100	CP Diverter Valve Assembly
3309047	DV-105	CP Deoseptic Diverter Assembly
3309052	DV-135	CP Deoseptic Diverter Assembly 2" Offset
3309061	DV-115	CP Deoseptic Diverter Assembly ADA
3309062	DV-115-R	CP Deoseptic Diverter Assembly ADA
3309065	DV-120	CP Diverter Assembly ADA 1-1/2" Offset
3309066	DV-120-R	CP Diverter Assembly ADA 1-1/2" Offset
3309069	DV-125	CP Deoseptic Diverter Assembly ADA Offset
3309070	DV-125-R	CP Deoseptic Diverter Assembly ADA Offset
3309051	DV-130	CP Diverter Assembly 2 Offset

SLIMLINE® BEDPAN REPAIR KITS

3309035	DV-1001	Kit Bedpan Washer Wall Support
3309036	DV-1002	Repair Kit Deoseptic Pivot
3309037	DV-1003	Repair Kit Bedpan Washer Pivot
3309040	DV-1004	Repair Kit Deoseptic Diverter
3309048	DV-1005	Conversion Kit Deoseptic Diverter Assembly
3309032	DV-1007	Repair Kit Spray Arm
3309077	DV-1014	Repair Kit 10" Spray Arm
3309044	DV-32-AA	Repair Kit 12" Spray Arm
3309015	DV-1017-A	Repair Kit 15" Spray Arm

REBUILDING THE SLOAN SLIMLINE DIVERTER ASSEMBLY:

To disassemble diverter valve: Loosen set screw and remove spray arm from pivot. Slide pivot out of diverter valve body.

To further disassemble deoseptic diverters:

Remove plug cap and retaining ring. Slide swivel and ball check assembly off pivot shaft, exposing all internal components.

NOTE: This disassembly can be done without removing pivot assembly from diverter valve body.

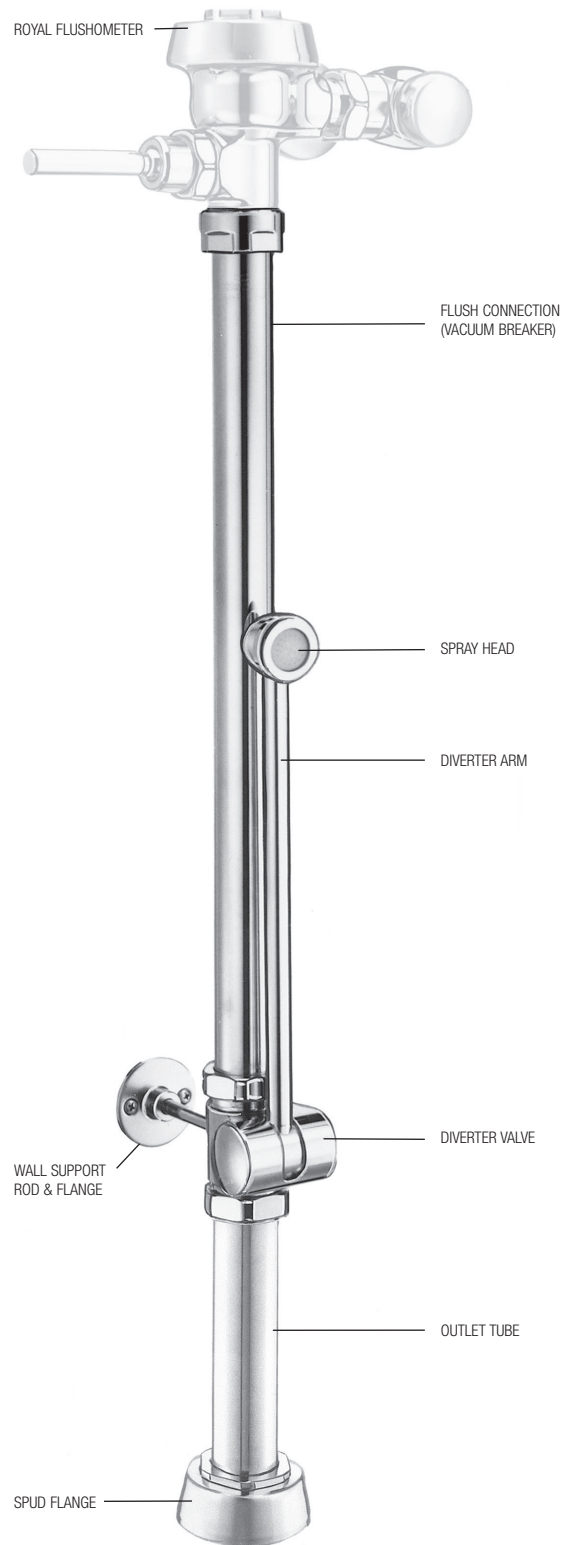
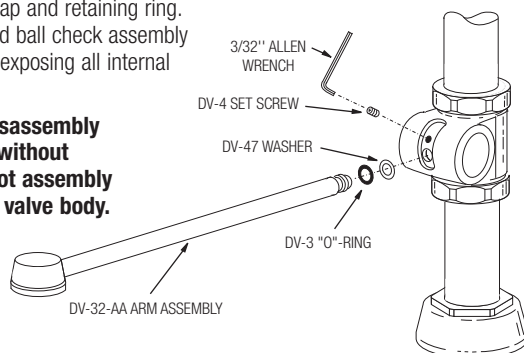

Slimline® Bedpan Washer Flushometer

TROUBLESHOOTING GUIDE

See Royal® flushometer troubleshooting section for all problems regarding the flushometer and the flushing discharge.

1. Diverter leaking at spray arm.

- A. Diverter spray arm (old style) is damaged. Replace diverter arm with new spray arm replacement kit. **NOTE: On old style diverter spray arm, the spray arm O-ring was placed on groove at the end of the spray arm. When installing new spray arm kit, place washer into bottom of hole of nozzle pivot. Then place the O-ring on top of washer. Insert new spray arm into the pivot, pressing in slightly. While holding spray arm in place, tighten set screw.**
- B. Spray arm O-ring is damaged or installed improperly. Re-install O-ring as described above in step (A.). If leakage persists replace using spray arm kit DV-1007-A.

2. Diverter leaking at nozzle pivot.

- A. One or both pivot O-rings are worn. Replace nozzle pivot assembly. Use pivot replacement kit.
- B. Diverter seal washer worn or missing. Replace pivot seals. Use diverter rebuild kit.
- C. Nozzle pivot damaged. Replace nozzle pivot assembly. Use pivot replacement kit.

3. Erratic spray pattern from spray arm nozzle.

- A. Debris clogging nozzle screen. Wash nozzle screen under running water.
- B. Damaged or missing nozzle screen or spray disc. Replace using DV-1007-A spray arm replacement kit.

4. Deoseptic solution not siphoning from bottle during flush cycle (deoseptic models only).

- A. Adjusting screw not open. Open adjusting screw until adequate amount of solution is siphoned from bottle during flush cycle.
- B. Aspirator tube screen clogged. Remove solution bottle. Remove aspirator tube from swivel & ball check assembly and wash screen under running water.
- C. Aspirator tube not installed completely onto swivel & ball check assembly. Remove solution bottle. Make sure aspirator tube is pushed completely onto nipple of swivel & ball check assembly.
- D. Aspirator tube cracked. Replace aspirator tube assembly.
- E. Rubber ball check stuck inside swivel & ball check assembly. Remove solution bottle and aspirator tube from swivel & ball check assembly. Gently insert small implement (paper clip, small dia. hex key, etc.) into nipple of swivel & ball check assembly to dislodge rubber ball check. Stop pushing once water starts to trickle from nipple.
NOTE: If ball is pushed too hard or too far it may fall out of seat. Should this occur, the swivel & ball check assembly must be removed and ball replaced. To do this, remove retaining ring using retaining clip pliers. Pull swivel & ball check assembly off of adjusting screw being careful not to drop rubber ball check. Place rubber ball back into seat of swivel & ball check assembly and reassemble. If ball and seals appear worn rebuild.

5. Water leaking back into solution bottle.

- A. Rubber ball damaged or missing. Replace rubber ball using DV-1004-A deoseptic diverter rebuild kit.
- B. Rubber ball not sitting in seat of swivel & ball check assembly. Remove swivel & ball check assembly taking care not to lose rubber ball. Insert rubber ball back into seat of swivel & ball check assembly and reassemble. **NOTE: Follow steps in solution (E.) of problem 4.**

CARE AND CLEANING INSTRUCTIONS

DO NOT USE abrasive or chemical cleaners to clean flushometers as they may dull the luster and attack the chrome or special decorative finishes. Use **ONLY** mild soap and water, then wipe dry with clean cloth or towel.

While cleaning the bathroom tile, the flushometer should be protected from any splattering of cleaner. Acids and cleaning fluids can discolor or remove chrome plating.

When assistance is required, please contact

Sloan Technical Support at: 1-888-SLOAN-14 (1-888-756-2614).

Optima® Flushometer

Current style Royal® (after 09/26/10)

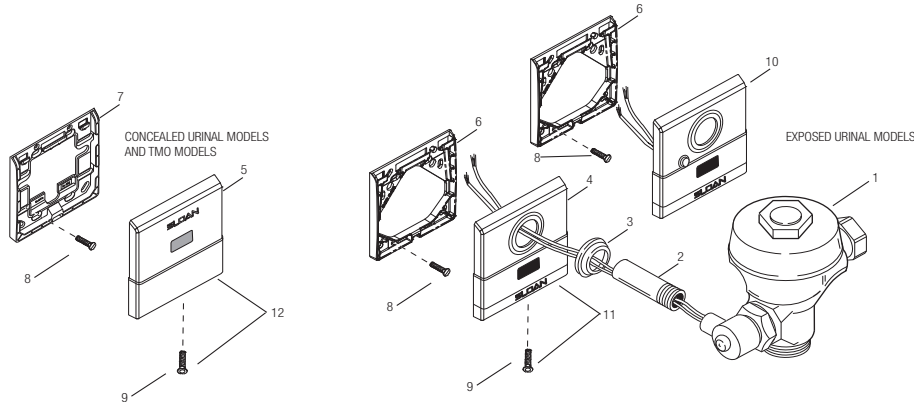

CURRENT COVER AND MOUNTING PLATE PARTS FOR ROYAL® URINAL FLUSHOMETER

Item No.	Code No.	Part No.	Description
1.	‡		Solenoid Activated Valve Assembly
2.	0306249PK	F-15	Tail Assembly 3/4" x 6"
3.	0345150	EL-431-A	Flange Assembly
4.	3305100	EL-640-A	CP Cover Plate with Sensor and Mounting Hardware Assembled (Exposed Models) (includes EL-549 mounting plate)
5.	3305101	EL-645-A	CP Cover Plate with Sensor Assembled (Concealed Models) (includes EL-592 Moutning Plate)
6.	0305251PK	EL-549-A	Exposed Urinal Mounting Plate Kit

Item No.	Code No.	Part No.	Description
7.	0305292PK	EL-592-A	Concealed Urinal Mounting Plate Kit
8.	—		Screws (Flat Head Slotted #6/32)
9.	5305100	EL-674	Wall Plate Screw Kit (#6-32 x 15.87mm)
10.	03455361	EL-680-A	CP Cover Plate with Sensor, OR Button and Mounting Hardware Assembled (Exposed Models) (includes EL-549 mounting plate)
†	3305620	EL-1500	Urinal Sensor Replacement (Exposed and Concealed Models, not shown)

† NOTE: For exposed & concealed solenoids manufactured before 2003 or not shown here, consult factory for individual part assembly. ‡ Part number varies with valve model variation; consult factory.

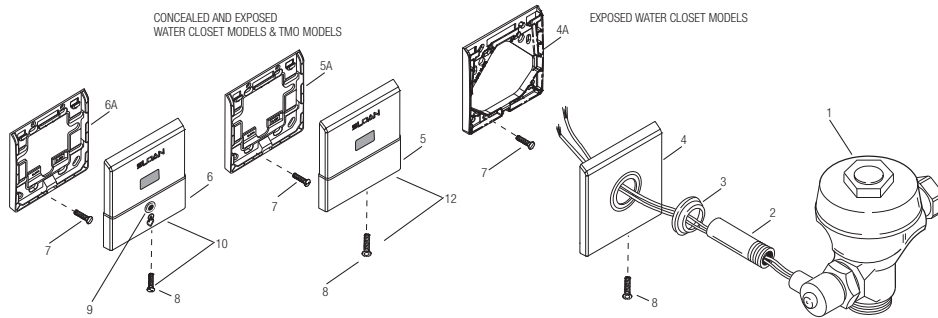

CURRENT COVER AND MOUNTING PLATE PARTS FOR ROYAL® CLOSET FLUSHOMETER

Item No.	Code No.	Part No.	Description
1.	‡		Solenoid Activated Valve Assembly
2.	0306249PK	F-15	Tail Assembly*
3.	0345150	EL-431-A	Flange Assembly
4.	3305105	EL-625-A	CP Cover Plate with Mounting Hardware (Closet only) (includes EL-549 mounting plate)
4A.	0305251PK	EL-549	Exposed Closet Mounting Plate
5.	3305107	EL-635-A	Concealed CP TMO Cover Plate with Sensor (includes Mounting Kit)
5A.	0305292PK	EL-592	Concealed Closet TMO Mounting Plate

Item No.	Code No.	Part No.	Description
6.	3305104	EL-595-A	CP Cover Plate with Sensor and Override Switch Assembled (Closet only) Exposed ES-S
6A.	0305292PK	EL-592	Exposed & Concealed Closet Mounting Plate
7.	—		Screws (Flat Head Slotted #6/32)
†	3305621	EL-1500-L	Closet Sensor Replacement Kit (Closet only, not shown)
	3345095	EL-1034-AB	Button Assembly Repair Kit
8.	5305100	EL-674	Wall Plate Screw Kit (#6-32 x 15.87mm) (6 per kit)
9.	3345095	EL-1034-A	ESS Override Repair Kit for EL-595-A

† NOTE: For exposed & concealed solenoids manufactured before 2003 or not shown here, consult factory for individual part assembly. ‡ Part number varies with valve model variation; consult factory.

* Mounting plates do not include sensor. For Solenoid Breakdown, see 58

PLATES ONLY

Item No.	Code No.	Part No.	Description
10.	3345090	EL-1030-A	Plate Assembly Only w/ Set Screw* (plate only for EL-595-A)
11.	3345091	EL-1031-A	Plate Assembly Only w/ Set Screw* (Plate only for EL-640-A)
12.	3345092	EL-1032-A	Plate Assembly Only w/ Set Screw* (Plate only for EL-635-A/EL-645-A)

Optima® Flushometer

Old Royal® until 05/09, current Sloan/Regal®



OPTIMA®

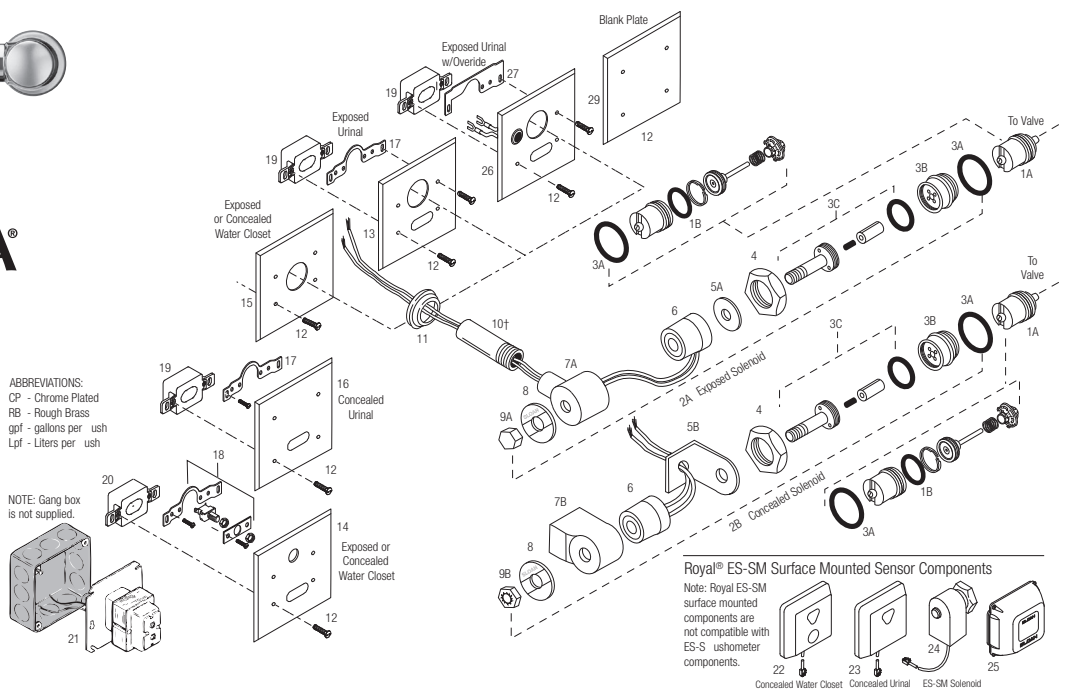

ABBREVIATIONS:
 CP - Chrome Plated
 RB - Rough Brass
 gpf - gallons per flush
 Lpf - Liters per flush

NOTE: Gang box is not supplied.

Royal® ES-SM Surface Mounted Sensor Components

Note: Royal ES-SM surface mounted components are not compatible with ES-S flushometer components.

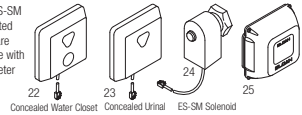

SOLENOID/SENSOR PARTS AND ASSEMBLIES LIST

Item No.	Code No.	Part No.	Description
1A.	3305043	EL-128-A	Actuator Cartridge Assembly Repair Kit Includes Spring, Plunger Guide, Solenoid Valve Seat, Valve Piston Assembly, and O-Ring (also available for ES-SM flushometers)
1B.	0305135	EL-110	O-Ring
2A.	0305328	EL-124-1	120V only (no sensor)
	3305044	EL-1029-A	CP Cartridge/Solenoid Kit EL-124-1 (120V) and EL128-A
	0305329	EL-124-2	24 VAC Solenoid Assembly (exposed installation) Includes Handle Coupling, 24 VAC Coil, Face Plate for 24 VAC Solenoid, Solenoid Adapter, Solenoid Shaft Assembly, Nut for Solenoid, Solenoid Housing, Solenoid Flux Plate, and O-Ring
	3305045	EL-1028-A	CP Cartridge/Solenoid Kit EL-124-2 (24V) and EL128-A
2B.	0305330	EL-138-1	120V only (no sensor)
	0305331	EL-138-2	24 VAC Solenoid Assembly (concealed installation) Includes Handle Coupling, 24 VAC Coil, Face Plate for 24 VAC Solenoid, Solenoid Adapter, Solenoid Shaft Assembly, Nut for Solenoid, Solenoid Base Plate and Solenoid Cover Assembly
3A.	0337086PK	DO-22	O-Ring
3B.	0305132PK	EL-104	RB Adapter for Solenoid
3C.	0305165PK	EL-163-A	Solenoid Shaft Assembly Includes Gasket, Plunger, Plunger Spring, and Solenoid Shaft
4.	0301082PK	A-6	CP Handle Coupling (exposed installation)
5A.	0305166PK	EL-164	Solenoid Flux Plate (exposed installation) fine thread
5B.	—	EL-542	N/A Separately
6.	0305119PK	EL-165-1	120 V Coil
	0305118PK	EL-165-2	24 VAC Coil
7A.	0345120PK	EL-162-2	CP Solenoid Housing (exposed installation) fine thread
	0305164PK	EL-162-1	CP Solenoid Housing (120V) course thread also used on pre-2001 24 V
7B.	0305967PK	EL-541-A	Solenoid Cover Assembly (Includes Flux Plate)
8.	0305127PK	EL-102-2	Face Plate for 24 VAC Solenoid (exposed installation)

Item No.	Code No.	Part No.	Description
9A.	0305125PK	EL-101	CP Nut for Solenoid (exposed installation)
9B.	0305167PK	EL-166	Housing Nut for Solenoid (concealed installation)
10.	0306249	F-15	Tail 1 3/4" X 6"
	0305145	EL-123-A	Old Style ESS 24V course thread (120V also)
	0305337PK	EL-226	1-1/4" Extension for EL-123-A course thread
11.	0345150	EL-431-A	CP Flange Assembly (exposed installation)
	0305139	EL-176-A	Old Style ESS 24V course thread (120V also)
12.	0305152PK	EL-152	CP Screws (requires four screws per cover plate) Size# 6-32
13.	0305151PK	EL-151	CP Cover Plate for Sensor and Solenoid Operator (Urinal only) (L/L Variation-0305150)
14.	0305219PK	EL-201	CP Cover Plate for Sensor and Override Button (Closet only)
15.	0318066PK	HY-66	CP Cover Plate for Solenoid Operator (Closet only)
16.	0305161PK	EL-161	CP Cover Plate for Sensor
17.	0305323	EL-168-A	Yoke Assembly (Urinal only)
18.	0305324	EL-141-A	Override Switch and Yoke Assembly (Closet only)
19.	3305620	EL-1500	Urinal Sensor Replacement Kit (Urinal only)
20.	3305621	EL-1500-L	Closet Sensor Replacement Kit (Closet only)
21.	0345154PK	EL-154	Transformer (120 VAC) (also available for ES-SM flushometers) 50 VA plate mount
	0345999PK	EL-342	Transformer (240 VAC) (also available for ES-SM flushometers) 50 VA plate mount
22.	3345047	EL-461	Surface Mounted Sensor and Override Button Assembly (closet only)
23.	3345048	EL-497	Surface Mounted Sensor Assembly (urinal only)
24.	0305802	EL-297	Solenoid Assembly
25.	3365003	ETF-492-A	Control Module
26.	0345266	EL-566-A	Exposed Plate with Override Button (Urinal only)
27.	0345267	EL-567-A	Yoke Assembly for EL-566-A
28.	3345080	EL-1026-A	ESS to TMO Retrofit Kit (Exposed)*
—	0305148	EL-227	Repair Tool Kit for EL-163-A Repair Kit
—	0345016	EL-387-A	Override Button Replacement for EL-566-A
—	3345021	EL-1010-A	O-ring Repair Kit*
29.	0305186PK	EL-139	Blank Plate

† NOTE: For exposed & concealed solenoids manufactured before 2001 or not shown here, consult factory for individual part assembly. * Not Shown

Optima® Royal® Flushometer

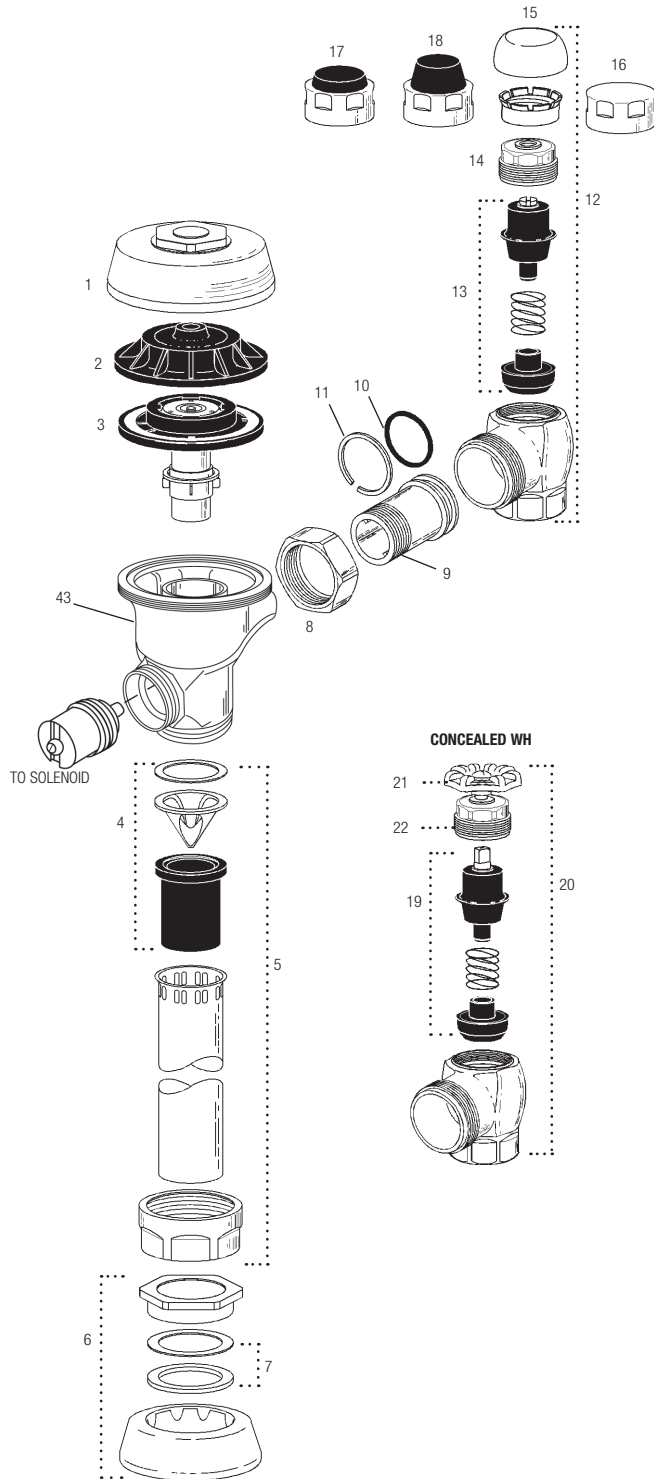

ABBREVIATIONS:
 CP Chrome Plated
 RB Rough Brass
 SD Screwdriver
 WH Wheel Handle
 gpf gallons per flush
 Lpf Liters per flush

Item No.	Code No.	Part No.	Description
1.	0301172PK	A-72	CP Cover
2.	0301168	A-71	Inside Cover
3.	SEE DIAPHRAGM ASSEMBLY CHART ON PAGE 24		
4.	3323182	V-651-A	Vacuum Breaker Repair Kit
5.	3393004	V-600-AA	3/4" (19 mm) x 9" (229 mm) CP Vacuum Breaker
	3393006	V-600-AA	1-1/4" (32 mm) x 9" (229 mm) CP Vacuum Breaker
	3393007	V-600-AA	1-1/2" (38 mm) x 9" (229 mm) CP Vacuum Breaker
6.	0306125	F-5-AW	3/4" (19 mm) CP Spud Coupling Assembly
	0306140	F-5-AU	1-1/4" (32 mm) CP Spud Coupling Assembly
	0306146	F-5-AT	1-1/2" (38 mm) CP Spud Coupling Assembly
7.	SEE SLIP JOINT GASKETS AND RINGS TABLE ON PAGE 15		
8.	0308676PK	H-550	CP Stop Coupling
9.	0308801	H-551-A	CP Adjustable Tail 2-1/16" (52 mm) long
10.	5308696	H-553	O-Ring – 24 per package
11.	5308381	H-552	Locking ring – 12 per package
12.	3308386	H-700-A	1" (25 mm) Screwdriver Bak-Chek® Angle Stop CP – complete
	3308384	H-700-A	3/4" (19 mm) Screwdriver Bak-Chek® Angle Stop CP – complete
13.	3308853	H-541-A-SD	Control Stop Repair Kit for use with 1" (25 mm) H-700-A & 3/4" (19 mm) H-700-A, 1" (25 mm) H-600-A, 1" (25 mm) & 3/4" (19 mm) H-700-A and 1" (25 mm) H-540-A SD Stops
	3308856	H-543-A-SD	Control Stop Repair Kit for use with 3/4" (19 mm) H-600-A and H-540-A SD Stops
14.	0308612PK	H-622 CP	Bonnet for use with 1" (25 mm) & 3/4" (19 mm) H-700-A and 1" (25 mm) H-600-A SD Stops
	0308843	H-577	CP Bonnet for use with 3/4" (19 mm) H-600-A SD Stops – DISCONTINUED
15.	3308772	H-1010-A	1" (25 mm) Vandal Resistant Control Stop Cap Assembly for use with 1" (25 mm) & 3/4" (19 mm) H-700-A and 1" (25 mm) H-600-A SD Stops
	3308790	H-1009-A	3/4" (19 mm) Vandal Resistant Control Stop Cap Assembly for use with 3/4" (19 mm) H-600-A SD
16.	3308840	H-573	1" (25 mm) Control Stop Cap CP for use with 1" (25 mm) & 3/4" (19 mm) H-700-A and 1" (25 mm) H-600-A SD Stops
	0308848PK	H-582	3/4" (19 mm) Control Stop Cap CP for use with 3/4" (19 mm) H-600-A SD Stops
17.	3308866	H-574	1" (25 mm) Control Stop Cap with Bumper for use with 1" (25 mm) & 3/4" (19 mm) H-700-A and 1" (25 mm) H-600-A SD Stops
18.	3308867	H-576	1" (25 mm) Control Stop Cap with Extended Bumper for use with 1" (25 mm) & 3/4" (19 mm) H-700-A and 1" (25 mm) H-600-A SD Stops
19.	3308860	H-1006-A	Repair Kit for 1" (25 mm) Stops with Concealed WH for use with 1" (25 mm) H-700-A, H-600-A, and H-543-AWH WH Series Stops
	3308859	H-1007-A	Repair Kit 3/4" (19 mm) Stops with Concealed WH for use with 3/4" (19 mm) H-700-A WH Series Stops
20.	0388010	H-730-A	1" (25 mm) Concealed WH Bak-Chek® Angle Stop RB
	0388011	H-730-A	3/4" (19 mm) Concealed WH Bak-Chek® Angle Stop RB
21.	3308872	H-1011-A	Repair Kit (for Concealed WH only; does not include bonnet)
42.	0208083PK	H-623	Bonnet
	0308705	H-561	Bonnet – DISCONTINUED
43.	0301048	A-143-A	CP Valve Body includes (H-550) coupling, (H-551) tailpiece, (H552) Locking Ring & (H553) O-ring
	0301050	A-143-A	RB Valve Body includes (H-550) coupling, (H-551) tailpiece, (H552) Locking Ring & (H553) O-ring
	0301065PK	A3SPL-1	CP Valve Body ONLY
	3388015	H-1015-A	Flow Control Kit (HEU Only) (not Shown)

Optima® Regal® Flushometer

NOTE: Also for use with Regal® XL (Since mid-2010)

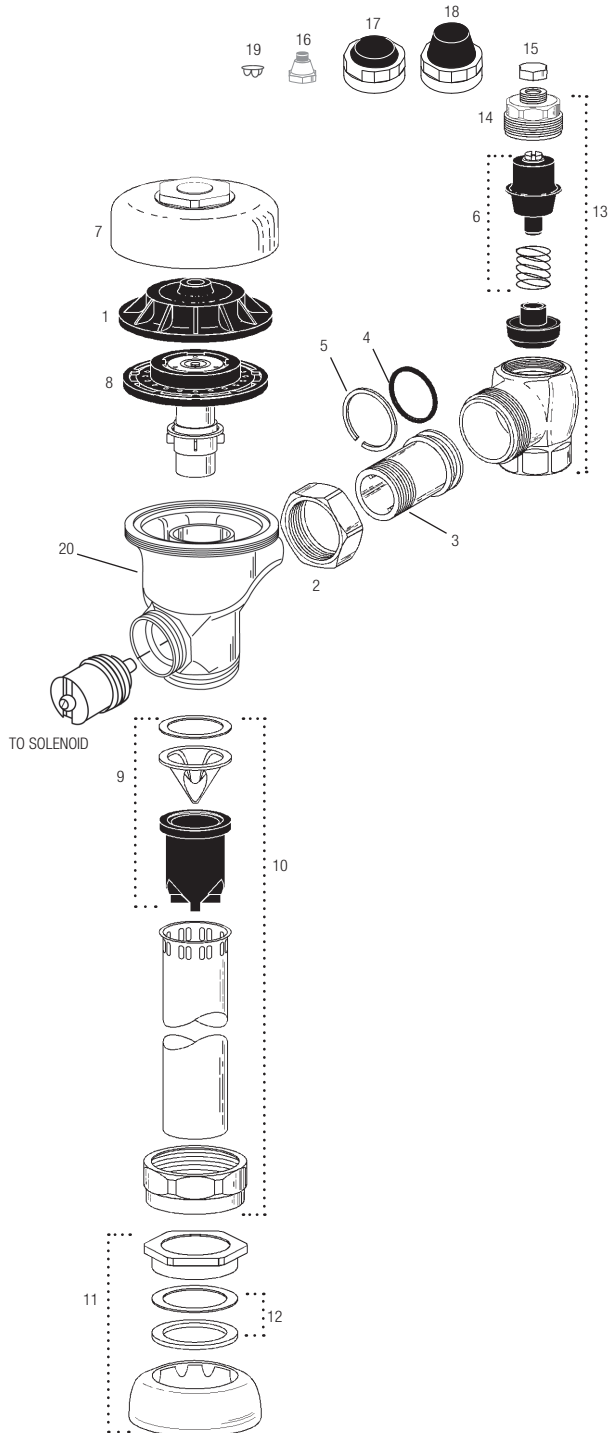

OPTIMA® REGAL® FLUSHOMETER PARTS LIST

Item No.	Code No.	Part No.	Description
1.	0301168	A-71	Inside Cover
2.	0308676PK	H-550	CP Stop Coupling
3.	0308801	H-551-A	CP Adjustable Tail 2-1/16" (52 mm) long
4.	5308696	H-553	O-Ring – 24 per package
5.	5308381	H-552	Locking ring – 12 per package
6.	3308853	H-541-A-SD	Control Stop Repair Kit for use with 1" (25 mm) H-700-A & 3/4" (19 mm) H-700-A, 1" (25 mm) H-600-A, 1" (25 mm) & 3/4" (19 mm) H-700-A and 1" (25 mm) H-540-A SD Stops
	3308856	H-543-A-SD	Control Stop Repair Kit for use with 3/4" (19 mm) H-600-A
7.	0317004PK	R-10	CP Cover
8.	SEE INSIDE PARTS ASSEMBLY CHART PAGE 61		
9.	3323192	V-551-A	Vacuum Breaker Repair Kit
10.	5323005	V-500-AA	3/4" (19 mm) x 9" (229 mm) CP Vacuum Breaker
	5323006	V-500-AA	1-1/4" (32 mm) x 9" (229 mm) CP Vacuum Breaker
	5323007	V-500-AA	1-1/2" (38 mm) x 9" (229 mm) CP Vacuum Breaker
11.	0306102	F-54-A	3/4" (19 mm) CP Spud Coupling Assembly
	0306142	F-55-A	1-1/4" (32 mm) CP Spud Coupling Assembly
	0306145	F-56-A	1-1/2" (38 mm) CP Spud Coupling Assembly
12.	SEE SLIP JOINT GASKETS AND RINGS TABLE BELOW		
13.	0388065	H-790-A	1" Screwdriver Stop Adjustable
	0388064	H-790-A	3/4" Screwdriver Stop Adjustable
	0388029	H-740-A	1" (25 mm) SD Bak-Chek® Stop CP – complete DISCONTINUED
	0388031	H-740-A	3/4" (19 mm) SD Bak-Chek® Stop CP – complete DISCONTINUED
14.	0308612PK	H-622	CP Bonnet (Current Regal®)
	0308991	H-639	CP Bonnet for use with 1" (25 mm) & 3/4" (19 mm) H-700-A and 1" (25 mm) H-540-A SD Stops – Pre 2010 Regal® Stops DISCONTINUED
	0308601	H-538	CP Bonnet for use with H-700-A 3/4" (19 mm) SD Stop – DISCONTINUED
15.	5388001	H-1012-A	CP Cap – 6 per package VP
16.	5310034	J-2/J-7	Bumper Assembly – 6 per package DISCONTINUED
17.	3308866	H-574	Stop Cap, chrome plated with Seat Bumper (-YO)
18.	3308867	H-576	Stop Cap, chrome plated with Extended Seat Bumper (-YG)
19.	5388002	H-528	Hole Plug
20.	0301048	A-143-A	CP Valve Body
	0301050	A-143-A	RB Valve Body
	0301065PK	A3SPL-1	CP Valve Body ONLY
	3388015	H-1015-A	Flow Control Kit (HEU Only) (not Shown)

NOTE: Also refer to the Royal®, Regal®, control stop and flush connection sections.

ITEM 31A. SLIP JOINT GASKETS AND RINGS

Size	Code No.	Part No.	Description
1-1/2"	5306058	F-3	Red Friction Ring
	5322001	VBF-5	Black Slip Joint Gasket
	5319086	S-30	Flexible Seat
	0319079	S-21	Rigid Seat (rubber over brass)
1-1/2" x 1-1/4"	0396062	F-105	Slip Joint Gasket – Rigid
1-1/4"	5306057	F-3	Red Friction Ring
	5322176	VBF-5	Black Slip Joint Gasket
	0307052/5307052	G-21	Rigid Seat (rubber over brass)
1"	5306056	F-3	Red Friction Ring
	5306115	F-5	Black Slip Joint Gasket
3/4"	5306055	F-3	Red Friction Ring
	5306113	F-5	Black Slip Joint Gasket

Optima® Flushometer

ROYAL® ESS (ITEM 24) REPAIR KIT

Code No.	Part No.	Description	Relief Valve	Refill Head*	Flow Ring
3345014	EL-1102-A	Water Saver Water Closets-3.5 gpf (13.2 Lpf)	White	Gray	Smooth
3345015	EL-1103-A	9 Liter European Water Closets-2.4 gpf (9.0 Lpf)	Blue	Gray	Smooth
3345013	EL-1101-A	Low Consumption Water Closets-1.6 gpf (6.0 Lpf)	Green	Gray	Smooth
3345083	EL-1109-A	High Efficiency Urinals-1.28 gpf (4.8 Lpf)	Blue	Gray	Smooth
3345018	EL-1108-A	Water Saver Urinals-1.5 gpf (5.7 Lpf)	Black	Black	Smooth
3345017	EL-1107-A	Low Consumption Urinals-1.0 gpf (3.8 Lpf)	Green	Black	Slotted
3345016	EL-1106-A	Wash Down Urinals-0.5 gpf (1.9 Lpf)	Green	Black	Smooth
3345093	EL-1105-A	High Efficiency Urinals-0.125 gpf (0.5 Lpf)	Blue	HEU Black	Smooth

ROYAL® DIAPHRAGM ONLY KIT

Code No.	Part No.	Description	Relief Valve	Refill Head*	Flow Ring
3301502	A-1041-A	Low Consumption Water Closets-1.6 gpf (6.0 Lpf)	Green	Gray	Smooth
3301501	A-1038-A	Water Saver Water Closets-3.5 gpf (13.2 Lpf)	White	Gray	Smooth
3301506	A-1045-A	High Efficiency Water Closets-1.28 gpf (4.8 Lpf)	Blue	Gray	Smooth
3301505	A-1044-A	9 Liter European Water Closets-2.4 gpf (9.0 Lpf)	Blue	Gray	Smooth
3301504	A-1043-A	Wash Down Urinals-0.5 gpf (1.9 Lpf)	Green	Black	Smooth
3321503	A-1042-A	Low Consumption Urinals-1.0 gpf (3.8 Lpf)	Green	Black	Slotted
3301500	A-1037-A	Water Saver Urinals-1.5 gpf (5.7 Lpf)	Black	Black	Smooth
3301142	A-1047-A	High Efficiency Urinals-0.25 gpf (1.0 Lpf) with White Inserts	White	HEU Black	Smooth
3301143	A-1050-A	High Efficiency Urinals-0.125 gpf (0.5 Lpf) with White Inserts	Blue	HEU Black	Smooth

*NOTE: Water closet refill heads (gray) have larger slots than urinal refill heads (black).

To identify the Flush Volume of a DUAL FILTERED DIAPHRAGM ASSEMBLY, look at the color of the relief valve, the refill head and the shape of flow ring.

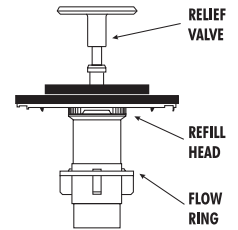

*NOTE: Water closet refill heads (gray) have larger slots than urinal refill heads (black).

REGAL® ESS (ITEM 28) INSIDE PARTS KITS ASSEMBLY

NOTE: Also for use with Regal® XL (Since mid-2010)

Code No.	Part No.	Description
3301036	A-36-A	4.5 gpf/17.0 Lpf-Closet
3301037	A-37-A	1.5 gpf/5.7 Lpf-Urinal
3301038	A-38-A	3.5 gpf/13.2 Lpf-Closet
3301041	A-41-A	1.6 gpf/6.0 Lpf-Closet
3301044	A-42-A	1.0 gpf/3.8 Lpf-Urinal
3301081	A-43-A	0.5 gpf/1.9 Lpf-Urinal
3301024	A-44-A	2.4 gpf/9.0 Lpf-Closet
3301045	A-140-A	1.28 gpf/4.8 Lpf- Closet

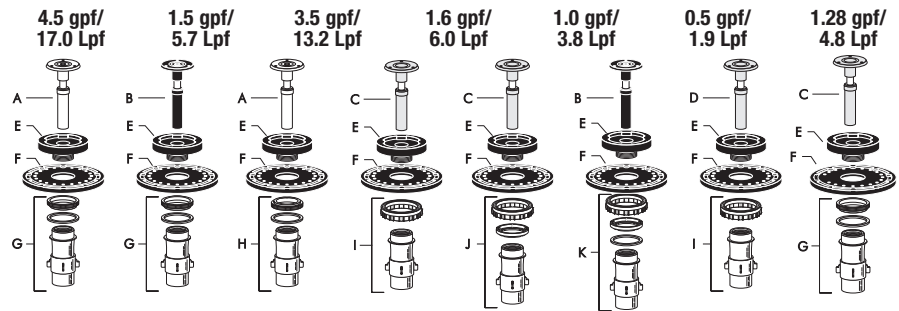

A-36-A Closet A-37-A Urinal A-38-A Closet A-41-A Closet A-42-A Urinal A-43-A Urinal A-44-A Closet A-140-A Closet

REGAL® INSIDE PARTS LIST** NOTE: Also for use with Regal® XL (Since mid-2010)

Item No.	Code No.	Part No.	Description
A.	5301058	A-19-AC	Relief Valve, White (Closet)
B.	5301059	A-19-AU	Relief Valve, Black (Urinal)
C.	5301211	A-19-ALC	Relief Valve, Green (Closet/Urinal-Low Consumption)
D.	0301143PK	A-19-AL	Relief Valve, Blue (9 Liter Closet)
E.	5301111	A-15-A	Disc
F.	5301188	A-156-A	Diaphragm
G.	5301236	A-163-A	Guide Assembly 4.5 gpf/17.0 Lpf Closet and 1.5 gpf/5.7 Lpf Urinal
H.	5301032	A-152-A	Guide Assembly 3.5 gpf/13.2 Lpf Closet
I.	5301031	A-151-A	Guide Assembly 1.6 gpf/6.0 Lpf Closet
J.	5301155	A-155-A	Guide Assembly 1.0 gpf/3.8 Lpf Urinal
K.	5301157	A-157-A	Guide Assembly 0.5 gpf/1.9 Lpf Urinal

**NOTE: All Regal® inside part items are supplied in 12 per package.

Optima® Flushometer

SOLENOID/SENSOR KITS LIST

Code No.	Part No.	Description
3305045	EL-124-2	CP 24 VAC Solenoid Assembly for exposed applications. Includes 24 VAC solenoid assembly and actuator cartridge assembly repair kit.
3305154	EL-1001-A	Closet flushometer Electronic Accessories Kit with Override. Includes screws, hex wrench, plate for 2-gang electrical box, mounting plate, override switch, yoke assembly, closet sensor replacement kit, an Optima® sticker and sensor Installation Instructions.
3305170	EL-1005-A	Exposed Urinal flushometer Electronic Accessories Kit. Includes plate for 2-gang electrical box, four screws, yoke, hex wrench, washer, urinal sensor replacement kit, an Optima® sticker and sensor Installation Instructions.
3305172	EL-1007-A	Concealed Urinal flushometer Accessories Kit. Includes screws, yoke, plate for 2-gang electrical box, hex wrench, washer, urinal sensor replacement kit, an Optima® sticker and sensor Installation Instructions.

WALL BOX KITS CLOSET MODELS

Code No.	Part No.	Description
3305180	EL-192-A	Closet Wall Box Kit – Stainless Steel. Includes four Mounting Screws, four Hex Nuts, four Lock Washers, Mounting Bracket, Electrical Box, Electrical Box Cover, Override Switch Subassembly, Wall Box 13" x 17" (330 mm x 432 mm) with 14.5" x 18.5" (368 mm x 470 mm) Stainless Steel Wall Box Cover with hole for override switch, Spanner Bit and Closet Sensor Replacement Kit.
3305160	EL-192-ALS	Same as EL-192-A. Sensor NOT included.

WALL BOX KITS URINAL MODELS

3305178	EL-191-A	Urinal Wall Box Kit – Stainless Steel. Includes Mounting Screws, Hex Nuts, Lock Washers, Wall Box 13" x 17" (330 mm x 432 mm) with 14.5" x 18.5" (368 mm x 470 mm) Stainless Steel Wall Box Cover, Mounting Bracket, Electrical Box, Electrical Box Cover, Spanner Bit, Urinal Sensor Replacement Kit.
3305158	EL-191-ALS	Same as EL-191-A. Sensor NOT included.

WALL BOX PARTS

0305845	EL-318	#8 Spanner Bit for WB-37 Spanner Screws
0334021	WB-37	Spanner Head Screws for ESS WB
5334000	WB-1000-A	6 Pack of WB-37 Screws
0305346	EL-216	Wall Box Frame and Stainless Steel Wall Box Cover for Water Closet. Mounting Hardware and Sensor NOT Included.
0305203	EL-193	Wall Box Frame and Stainless Steel Wall Box Cover for Urinal. Mounting Hardware and Sensor NOT Included.

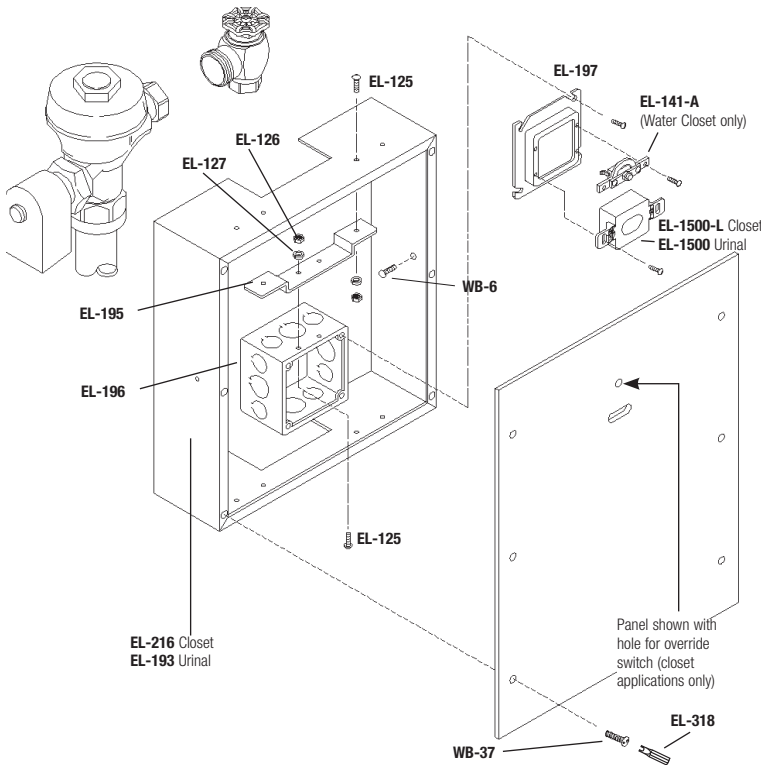

TYPICAL WIRING DIAGRAM FOR ONE FLUSH VALVE

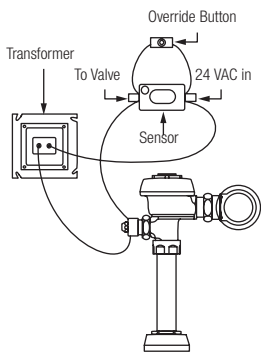

TYPICAL WIRING DIAGRAM FOR ONE OR MORE FLUSH VALVE(S)

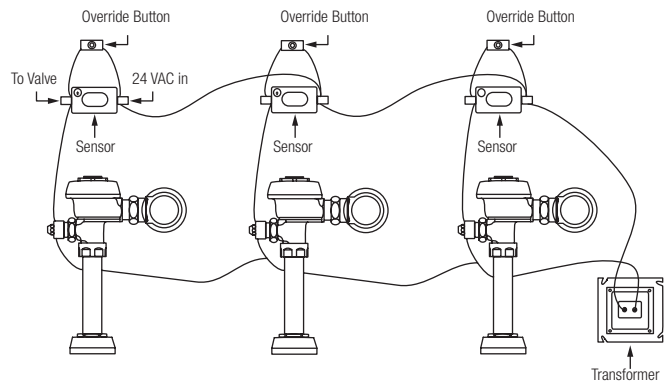

Optima® Flushometer

SENSOR REPLACEMENT

NOTE: The EL-1500 series Optima sensor (a two-wire unit) replaces the older EL-150 series sensors (either three-wire or four-wire units). Refer to the wiring history shown below.

IMPORTANT

- Be certain to disconnect the 24 VAC power supply either at the transformer or the fuse box. Failure to disable the power supply can result in damage to the EL-1500 series sensor.
 - The solenoid activated must be removed from the valve on exposed urinal installations. Do not damage the O-ring seal on the operator assembly.
1. Remove the cover plate (for wall box installation, remove cover panel) and old sensor from the wall installation. Use a 5/64" hex wrench to remove the cover plate screws (or #8 drilled spanner head screwdriver EL-318 to remove the vandal-resistant screws from the wall box cover panel.)
- FIGURE 1A
-
- FIGURE 1B
-
2. Connect one 24 VAC lead to the sensor terminal labeled "24 VAC IN" (see Figure 1B).
 - On an old three-wire series EL-150 sensor, this wire was connected to the BLACK sensor lead.
 - On an old four-wire series EL-150 sensor, this wire was connected to the BROWN sensor lead.
 3. Connect one solenoid lead to the sensor terminal labeled "TO VALVE" (see Figure 1B).
 - On an old three-wire or four-wire EL-150 series sensor, this wire was connected to the RED sensor lead.
 4. Connect the remaining 24 VAC lead to the remaining solenoid lead.
 - On an old three-wire series EL-150 sensor, these wires were connected to the WHITE sensor leads.
 - On an old four-wire EL-150 series sensor, these wires were connected to the YELLOW and BLUE (or in very early models, the inner BROWN) sensor leads.
 5. On Water Closet installations only, connect the override button (shown as the override switch in wiring diagram) parallel to the EL-1500-L sensor.
 6. Reinstall the sensor with the orientation arrow on the lens side of the sensor pointing UP (see Figure 1A). Replace the cover plate (or wall box panel) and tighten the cover plate (or wall box panel) screws.
 7. Reconnect the 24 VAC power supply at the transformer or the fuse box.

WIRING DIAGRAM

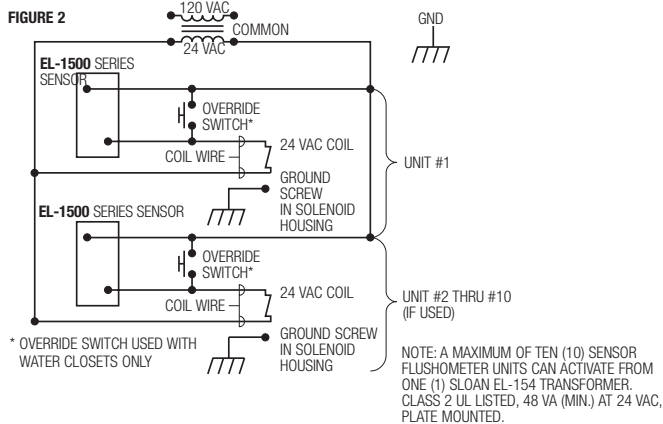

START-UP MODE

The self-adaptive sensor automatically adapts to the surrounding environment when 24 volt supply is activated. No manual adjustments are required. Start-up mode will take approximately one (1) minute to complete its cycle and is important that no non-permanent target is present at this time. A continuous red light visible in sensor window indicates sensor is in the start-up mode. If the red light is flashing, this indicates that the sensor is picking up a target. Unless this target is a permanent fixture in the sensor's environment (i.e., wall or stall door), it must be removed from the view of the sensor. Then, either disconnect the 24 volt supply for twenty (20) seconds, or push the manual override button for twenty (20) seconds in closet set-up. Reconnect the 24 VAC power supply at the transformer or the fuse box. When the start-up cycle is complete, there will be no light visible in the sensor window.

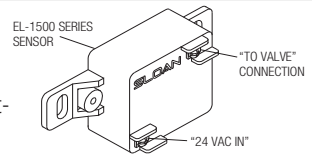

NOTE: If the 24 volt power supply is ever interrupted for longer than twenty (20) seconds, the start-up mode automatically begins when power is restored.

Incorrect wiring or a short in the 24 volt power supply is indicated by a continuous warning signal seen in the sensor window. The visible red light flashes an "SOS" signal: three (3) slow, three (3) fast, three (3) slow flashes.

SENSOR RANGE

Water Closets – EL-1500-L

Nominal: 15"-50" (381-1270 mm); Self-Adaptive Window: ± 17" (432 mm)

Urinals – EL-1500

Nominal: 12"-32" (305-813 mm); Self-Adaptive Window: ± 10" (254 mm)

START-UP MODE (FOR PREVIOUS SENSOR)

NOTE: It is important that only permanent targets are present at this time.

The self-adaptive sensor automatically adjusts to the surrounding environment when the 24 volt supply is activated. No manual adjustment is required. The start-up cycle completes in approximately five (5) minutes. A continuous red light visible in the sensor window indicates the start-up mode. If the red light flashes, the sensor detects a target. Unless this target is a permanent fixture in the sensor's environment (i.e., a wall or stall door), it must be removed from the view of the sensor. If a target is permanent, the sensor will adapt itself around this target. In this case, the start-up mode may take up to ten (10) minutes. When the start-up cycle is complete, there will be no light visible in the sensor window.

NOTE: If the 24 volt power supply is ever interrupted for longer than fifteen (15) seconds, the start-up mode begins automatically when power is restored.

Incorrect wiring or a short in the 24 volt power supply will initiate a warning signal in the sensor window. The visible light flashes a continuous "S-O-S" signal: three (3) fast, three (3) slow, and three (3) fast flashes.

EL-150 Wiring History for 4-wire and 3-wire sensors

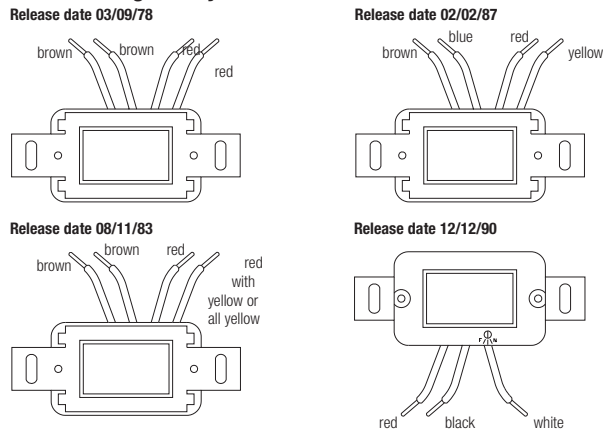

Optima® Flushometer

TROUBLESHOOTING GUIDE

ATTENTION INSTALLERS: With the exception of the control stop inlet, DO NOT USE pipe sealant or plumbing grease on any valve component or coupling! To protect the chrome or special finish of Sloan flushometers, DO NOT USE toothed tools to install or service these valves. Use our A-50 Super-Wrench™ or other smooth-jawed wrench to secure couplings. Regulations for low consumption fixtures (1.6 gpf/6.0 Lpf closets and 1.0 gpf/3.8 Lpf urinals) prohibit use of higher flush volumes.

Urinals (EL-1500 Sensor)

When the sensor detects a user, a slow flashing red light appears in the sensor window. After eight (8) to ten (10) seconds, the light flashes rapidly to indicate that the sensor is armed. When the sensor no longer detects a user, the sensor immediately activates the solenoid valve after a 0.5 second delay.

Water Closets (EL-1500-L Sensor)

When the sensor detects a user, a slow flashing red light appears in the sensor window. After approximately sixteen (16) seconds, the light will flash rapidly indicating sensor is armed. When the sensor no longer detects a user, the sensor immediately activates the solenoid after a 3 second delay.

1. Valve does not function (red light does not flash when user steps in front of sensor).

- No power is being supplied to sensor. Ensure that the main power is turned "ON". Check transformer, leads and connections. Repair or replace as necessary.
- EL-1500/EL-1500-L sensor is not operating. Replace sensor.

2. Valve does not function (red light flashes when user steps in front of sensor).

INDICATOR: The red light stops flashing when user steps away and the valve makes a "clicking" sound but does not flush.

- No water is being supplied to the valve. Make certain that water supply is turned "ON" and the control stop is open.
- EL-128-A cartridge is fouled or jammed. Turn electronic power to valve "OFF" (failure to do so could result in damage to the solenoid coil). Remove the solenoid operator from the valve and remove the EL-128-A cartridge. Clean and/or repair as necessary.

INDICATOR: The red light stops flashing when user steps away but the valve does NOT make a "clicking" sound and does NOT flush.

- EL-163-A solenoid shaft assembly is fouled or jammed. Turn electronic power to valve "OFF" (failure to do so could result in damage to the solenoid coil). Remove EL-101 or EL-166 nut from the solenoid operator. Remove the coil from the solenoid operator. Use a spanner wrench or pliers to remove the EL-163-A solenoid shaft assembly from valve. Clean and/or replace as necessary. Be sure to replace plunger spring when reassembling solenoid shaft assembly.

INDICATOR: The red light flashes three (3) fast flashes, three (3) slow flashes then three (3) fast flashes ("S-O-S") and continues to repeat this cycle even when user steps out of the sensor's detection range.

- EL-1500/EL-1500-L sensor wiring connections are incorrect. Rewire sensor to valve. One solenoid lead connects to the "TO VALVE" connection on sensor. One transformer lead connects to the "24 VAC IN" connection on sensor. Second solenoid lead and second transformer lead connect together.
- Wiring to sensor is ground shorted. Find short in wiring circuit and correct.
- EL-165-2 solenoid coil is burnt out or coil is not connected to solenoid plunger shaft. Reinstall or replace coil as necessary.

3. Range too short.

- Power down unit for 30 seconds. Power up. Wait six (6) minutes for calibration.
- If reset does not work, replace.

4. Volume of water is insufficient to adequately siphon fixture.

- Control stop is not open wide enough. Adjust control stop for desired water delivery.
- Low consumption unit is installed on water saver or conventional fixture. Replace diaphragm component parts of valve with kit that corresponds to appropriate flush volume of fixture.
- Inadequate water volume or pressure available from supply. Increase pressure or supply (flow rate) to the valve.

5. Length of flush too long (long flushing) or valve fails to shut off.

- Water saver valve is installed on low consumption fixture. Replace diaphragm component parts of valve with kit that corresponds to appropriate flush volume of fixture.
- Relief valve in diaphragm is not seated properly or the by-pass hole in diaphragm is clogged. Disassemble inside diaphragm component parts and wash parts thoroughly. Replace worn parts if necessary.

6. Water splashes from fixture.

- Supply flow rate is more than necessary. Adjust control stop to meet flow rate required for proper cleansing of the fixture.
- Closet valve is installed on urinal fixture. Replace closet diaphragm component parts with proper urinal kit (inside diaphragm assembly or inside parts kit).

CARE AND CLEANING INSTRUCTIONS

DO NOT USE abrasive or chemical cleaners to clean flushometers or sensor that may dull the luster and attack the chrome or special decorative finishes. Use **ONLY** mild soap and water, then wipe dry with a clean towel or cloth.

When cleaning the bathroom tile, protect the flushometer from any splattering of cleaner. Acids and cleaning fluids can discolor or remove chrome plating.

When assistance is required, please contact Sloan Technical Support at: 1-888-SLOAN-14 (1-888-756-2614).

Optima® Royal® ES-S TMO Exposed Flushometer

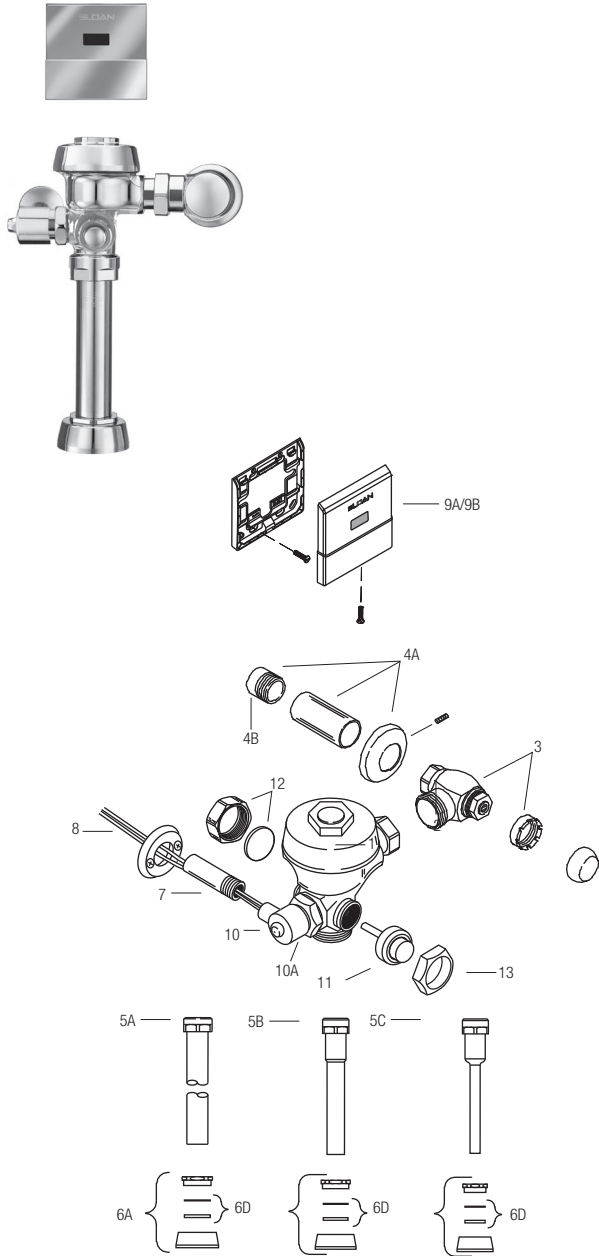

ROYAL® OPTIMA® ES-S TMO EXPOSED FLUSHOMETER PARTS LIST

Item No.	Code No.	Part No.	Description
1.	‡		Solenoid Activated Valve Assembly
2.	‡	H-700-A	Bak-Chek® Control Stop
3.	3308772	H-1010-A	Vandal Resistant Stop Cap
4A.	3308782	H-633-AA	1" (25 mm) Sweat Solder Kit
4B.	3308603	H-532	Adapter, 1" NPT to 1" Tube
	3308607	H-535	Adapter, 3/4" NPT to 3/4" Tube
5A.	—	V-600-AA	1-1/2" (38 mm) Vacuum Breaker Assembly CP (Models 110/111, 115, and 116)
5B.	—	V-600-AA	1-1/4" (32 mm) x 9" (229 mm) Vacuum Breaker Assembly CP (Model 180 ES-S)
5C.	—	V-600-AA	3/4" (19 mm) x 9" (229 mm) Vacuum Breaker Assembly CP (Model 186 ES-S)
6A.	0306146	F-5-AT	1-1/2" (38 mm) Spud Coupling Assembly CP (Models 110/111, 115, and 116)
6B.	0306140	F-5-AU	1-1/4" (32 mm) Spud Coupling Assembly CP (Model 180)
6C.	0306125	F-5-AW	3/4" (19 mm) Spud Coupling Assembly CP (Model 186)
6D.	SEE SLIP JOINT GASKETS AND RINGS ON TABLE BELOW		
7.‡	F-15		Tail Assembly
8.	0302323PK	B-110-A	Flange Assembly
9A.	3305107	EL-635-A	CP Cover Plate with Sensor (Mounting Plate and Screws included) (Models 110/111, 115, and 116)
9B.	3305101	EL-645-A	CP Cover Plate with Sensor (Mounting Plate and Screws included) (Models 180 and 186)
10.	0305329	EL-124-2	CP 24V Solenoid Assembly Only
10A	3305043	EL-128-A	Actuator Cartridge Assembly (not shown detailed)
	3305045	EL-1028-A	Solenoid Assembly w/ Cartridge Assembly
11.	0303009	C-2-A	True Mechanical Override Button
12.	3325814	EBV-1017-A	CP Valve Handle Cap
13.	0301082PK	A-6	CP Nut
—	3345080	EL-1026-A	ES-S to ES-S-TMO Conversion Kit Exposed (not Shown) includes Body/Tail assembly (no inside parts or covers) #11, #12, #13, DO-22 and EL-110 o-rings
—	3305043	EL-128-A	Actuator Cartridge (not Shown)
—	3302306	B-51-A	Triple Seal Handle Repair Kit (not Shown)
	3388015	H-1015-A	Flow Control Kit (HEU Only) (not Shown)

‡ Part number varies with valve model variation; consult factory.

* Not shown

ITEM 6D. SLIP JOINT GASKETS AND RINGS

Size	Code No.	Part No.	Description
1-1/2"	5306058	F-3	Red Friction Ring
	5322001	VBF-5	Black Slip Joint Gasket
	5319086	S-30	Flexible Seat
	0319079	S-21	Rigid Seat (rubber over brass)
1-1/2" x 1-1/4"	0396062	F-105	Slip Joint Gasket – Rigid
1-1/4"	5306057	F-3	Red Friction Ring
	5322176	VBF-5	Black Slip Joint Gasket
	0307052/5307052	G-21	Rigid Seat (rubber over brass)
1"	5306056	F-3	Red Friction Ring
	5306115	F-5	Black Slip Joint Gasket
3/4"	5306055	F-3	Red Friction Ring
	5306113	F-5	Black Slip Joint Gasket

Optima® Royal® ES-S TMO Concealed Flushometer

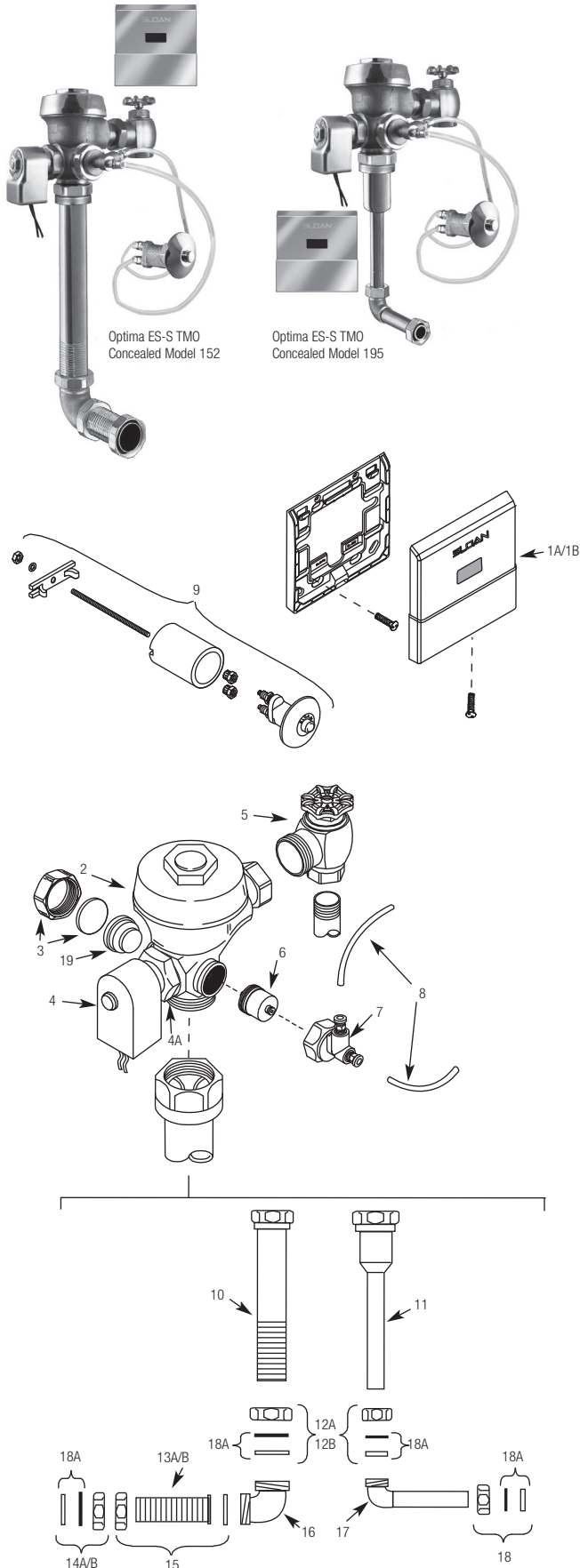

ROYAL® OPTIMA® ES-S TMO CONCEALED FLUSHOMETER PARTS LIST

Item No.	Code No.	Part No.	Description
1A.	3305107	EL-635-A	CP Cover Plate with Sensor (Mounting Screws included) (Model 152)
1B.	3305101	EL-645-A	CP Cover Plate with Sensor (Mounting Screws included) (Model 195)
2.	‡	—	Valve Assembly
3.	3301093	A-1013-A	Concealed Valve Handle Cap RB
4.	0305331	EL-138-2	RB Concealed 24V Solenoid Assembly
4A.	3305043	EL-128-A	Actuator Cartridge Assembly Only
5.	‡	H-730-A	RB Bak-Chek® Control Stop
6.	3318001	HY-83-A	Actuator Cartridge
7.	3318005	HY-109-A-1	Valve Actuator Assembly
8.	0318093	HY-30	1/4" (6 mm) x 48" (1219 mm) Connecting Tubes
9.	0318117	HY-100-A-1	Metal Push Button Assembly
10.	‡	V-500-AA	1-1/2" (38 mm) Vacuum Breaker Assembly RB (Model 152)
11.	‡	V-500-AA	3/4" (19 mm) Vacuum Breaker Assembly RB (Model 192)
12A.	0306088	F-2-AT	1-1/2" (38 mm) Slip Joint Coupling Assembly RB (Model 152)
12B.	0306054	F-2-AW	3/4" (19 mm) Slip Joint Coupling Assembly RB (Model 192)
13A.	‡	F-110	1-1/4" (32 mm) Outlet Tube with Flange and Scoring (Model 190)
13B.	‡	F-100	1-1/2" (38 mm) Outlet Tube with Flange and Scoring (Model 190)
14A.	0306059	F-2-AU	1-1/4" (32 mm) Slip Joint Coupling Assembly RB (Model 152)
14B.	0306088	F-2-AT	1-1/2" (38 mm) Slip Joint Coupling Assembly RB (Model 152)
15.	0306091	F-2-A	1-1/2" (38 mm) Coupling with S-21 Gasket (Model 152)
16.	0206146PK	F-21	1-1/2" (38 mm) Double Male Slip Joint Elbow
17.	‡	F-15-A	ELL with 3/4" (19 mm) Tail
18.	0306054	F-2-AW	3/4" (19 mm) Slip Joint Coupling
18A.	SEE SLIP JOINT GASKETS AND RINGS TABLE BELOW		
19.	0305190	EL-190-A	Handle Adapter Assembly
	3345020	EL-1033-A	ESS to TMO Retrofit Kit (Concealed)*
	3388015	H-1015-A	Flow Control Kit (HEU Only) (not Shown)

‡ Part number varies with valve model variation; consult factory.

* Not Shown

ITEM 18A. SLIP JOINT GASKETS AND RINGS

Size	Code No.	Part No.	Description
1-1/2"	5306058	F-3	Red Friction Ring
	5322001	VBf-5	Black Slip Joint Gasket
	0319086/5319086	S-30	Flexible Seat
	0319079	S-21	Rigid Seat (rubber over brass)
1-1/2" x 1-1/4"	0396062	F-105	Slip Joint Gasket – Rigid
1-1/4"	5306057	F-3	Red Friction Ring
	5322176	VBf-5	Black Slip Joint Gasket
	0307052/5307052	G-21	Rigid Seat (rubber over brass)
1"	5306056	F-3	Red Friction Ring
	5306115	F-5	Black Slip Joint Gasket
3/4"	5306055	F-3	Red Friction Ring
	5306113	F-5	Black Slip Joint Gasket

Optima® CROWN® ES-S Exposed Flushometer

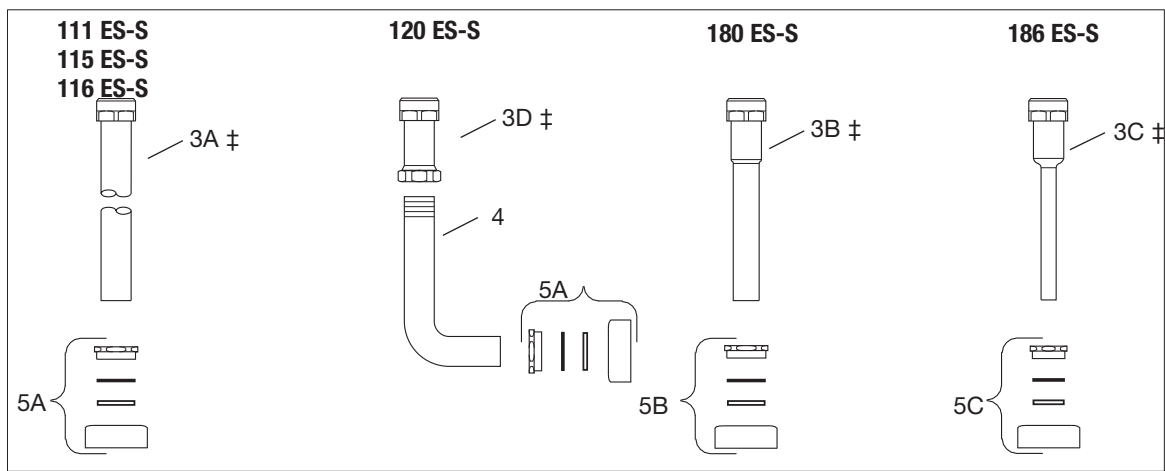
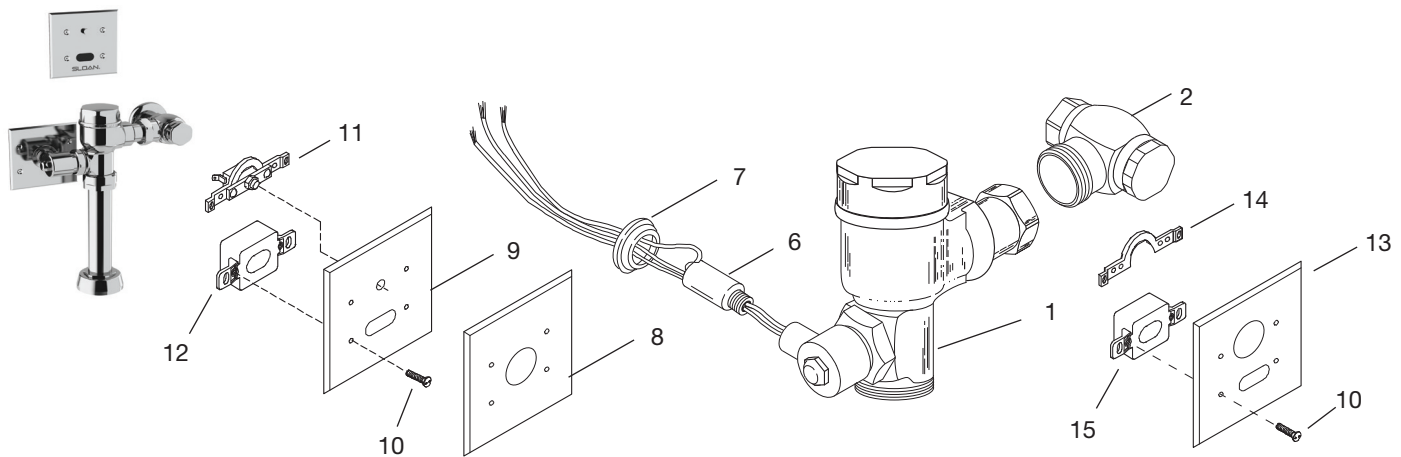

Item No.	Part No.	Description
1.	†	Solenoid Operated Valve Assembly
2.	H-700-A	Bak-Chek® Control Stop
3A.	V-600-AA	1-1/2" (38 mm) x 9" (229 mm) Vacuum Breaker Assembly CP (Model 111)‡
	V-600-AA	1-1/2" (38 mm) x 21" (533 mm) Vacuum Breaker Assembly CP (Model 115)‡
	V-600-AA	1-1/2" (38 mm) x 24" (610 mm) Vacuum Breaker Assembly CP (Model 116)‡
3B.	V-600-AA	1-1/4" (32 mm) x 9" (229 mm) Vacuum Breaker Assembly (Model 180)‡
3C.	V-600-AA	3/4" (19 mm) x 9" (229 mm) Vacuum Breaker Assembly CP (Model 186)‡
3D.	V-600-A	1-1/2" (38 mm) Vacuum Breaker Assembly (Model 120)‡
4.	F-109	1-1/2" (38 mm) Elbow Flush Connection (Model 120)
5A.	CR-1010-A	1-1/2" (38 mm) Spud Coupling Kit (Models 111, 115, 116 and 120)
5B.	CR-1009-A	1-1/4" (32 mm) Spud Coupling Assembly (Model 180 ES-S)
5C.	CR-1008-A	3/4" (19 mm) Spud Coupling Assembly (Model 186)
6.	EL-163-A	Nipple Assembly
7.	EL-431-A	Flange Assembly
8.	HY-66	Cover Plate (Closet)
9.	EL-201	Cover Plate (Closet)

Item No.	Part No.	Description
10.	EL-152	Screw (4 Required per Plate)
11.	EL-141-A	Yoke and Override Button Assembly (Closet)
12.	EL-1500-L	Sensor (Closet)
13.	EL-151	Cover Plate (Urinal)
14.	EL-168-A	Yoke Assembly (Urinal)
15.	EL-1500	Sensor (Urinal)

† Part number varies with valve model variation; consult factory.
 ‡ If valve was specified less vacuum breaker (XYV Variation), a straight flush tube is supplied in place of the vacuum breaker assembly. Consult factory for part number.

Piston Repair Kits

Part number varies with valve model variation; consult factory

Installation Templates:

For Model 111 ES-S: Code #0816157
 For Models 180/186 ES-S: Code # 0816156

Optima® CROWN® ES-S Exposed Flushometer

TROUBLESHOOTING GUIDE

1. **PROBLEM:** Valve does not function — red light DOES NOT flash when user steps in front of sensor.
 - CAUSE:**
 - a. No power to sensor.
 - b. EL-1500 or EL-1500-L sensor not operating.
 - SOLUTION:**
 - a. Make certain that power is on. Check transformer, leads & connections. Repair or replace as necessary.
 - b. Replace EL-1500 or EL-1500-L sensor.

2. **PROBLEM:** Valve does not function — red light flashes when user steps in front of sensor.

Under normal operation, the red light should flash slowly for the first (8) eight seconds of user detection. Light should then flash rapidly which indicates that the sensor is armed & ready to flush the fixture when user leaves the field of view.

If red light stops flashing when user steps away & valve makes a “clicking” sound but DOES NOT flush:

 - CAUSE:**
 - a. Control stop or main valve is closed.
 - b. Relief valve is worn and sticking in UP position.
 - c. EL-128-A cartridge is fouled or jammed.
 - SOLUTION:**
 - a. Open control stop or main valve.
 - b. Replace piston.
 - c. Turn off power to valve. Remove solenoid operator from valve & remove EL-128-A cartridge. Clean and/or replace as necessary.

If red light stops flashing when user steps away & valve does not make a “clicking” sound & DOES NOT flush:

 - CAUSE:** EL-163-A solenoid shaft assembly is fouled or jammed.
 - SOLUTION:** Turn off power to valve. Remove coil from solenoid operator.

Using a spanner wrench or pliers, remove EL-163-A solenoid shaft assembly from valve. Clean and/or replace as necessary.

If red light is flashing (3) short flashes, (3) long flashes then (3) short flashes (S-0-S) and continues to repeat this cycle even when the user steps away from the valve:

 - CAUSE:**
 - a. EL-1500 or EL-1500-L sensor is wired incorrectly.
 - b. Wiring to sensor is ground shorted.
 - c. EL-165-2 solenoid coil burned out or coil is off solenoid plunger shaft.
 - SOLUTION:**
 - a. Rewire sensor and valve properly.
 - b. Find short in wiring and correct.
 - c. Reinstall or replace coil as necessary.

3. **PROBLEM:** Insufficient volume of water to adequately siphon fixture.
 - CAUSE:**
 - a. Control stop not open enough.
 - b. Urinal piston parts inside a closet valve.
 - c. Low consumption valve installed on a non-low consumption fixture.
 - d. Inadequate volume or pressure at supply.
 - SOLUTION:**
 - a. Adjust control stop for desired delivery of water.
 - b. Replace piston parts with proper closet piston.
 - c. Replace with proper flushometer. Crown & Crown II flushometers are not available with flush volume higher than 1.6 gpf/6.0 Lpf.
 - d. Increase water pressure or supply (flow) to valve.

4. **PROBLEM:** Length of flush too short (short flushing) or valve closes off immediately.
 - CAUSE:**
 - a. Piston assembly is not hand-tight.
 - b. Enlarged bypass orifice from corrosion or damage.
 - c. Urinal piston in closet flushometer.
 - d. Low consumption valve installed on a non-low consumption fixture.
 - SOLUTION:**
 - a. Screw the assembly hand-tight.
 - b. Install NEW piston assembly to correct problem & update flushometer.
 - c. Replace piston with proper closet piston.
 - d. Replace with proper flushometer. Crown & Crown II flushometers are not available with flush volume higher than 1.6 gpf/6.0 Lpf.

5. **PROBLEM:** Length of flush too long (long flushing) or fails to close off.
 - CAUSE:**
 - a. Piston is not seating properly or bypass orifice is clogged because of foreign material, or bypass orifice is clogged by an invisible gelatinous film from “over-treated” water.
 - b. Line pressure has dropped & is not sufficient to force relief valve to seat.
 - c. Main seat is fouled with debris or is worn.
 - SOLUTION:**
 - a. Disassemble the working parts and wash thoroughly. **NOTE:** Size of the orifice in the bypass is of utmost importance for the proper metering of water into the upper chamber of the valve. **DO NOT** enlarge or damage this orifice. Replace piston if cleaning does not correct problem.
 - b. Shut off all control stops until pressure has been restored, then open them again.
 - c. Clean or replace Main Seat.

6. **PROBLEM:** Water splashes from fixture.
 - CAUSE:** Supply volume is open more than necessary.
 - SOLUTION:** Adjust control stop to meet flow rate required for proper cleansing of the fixture.

If further assistance is required, please contact Sloan Technical Support at 1-888-SLOAN-14 (1-888-756-2614).

Optima® Royal® ES-S TMO (SWB) Flushometer

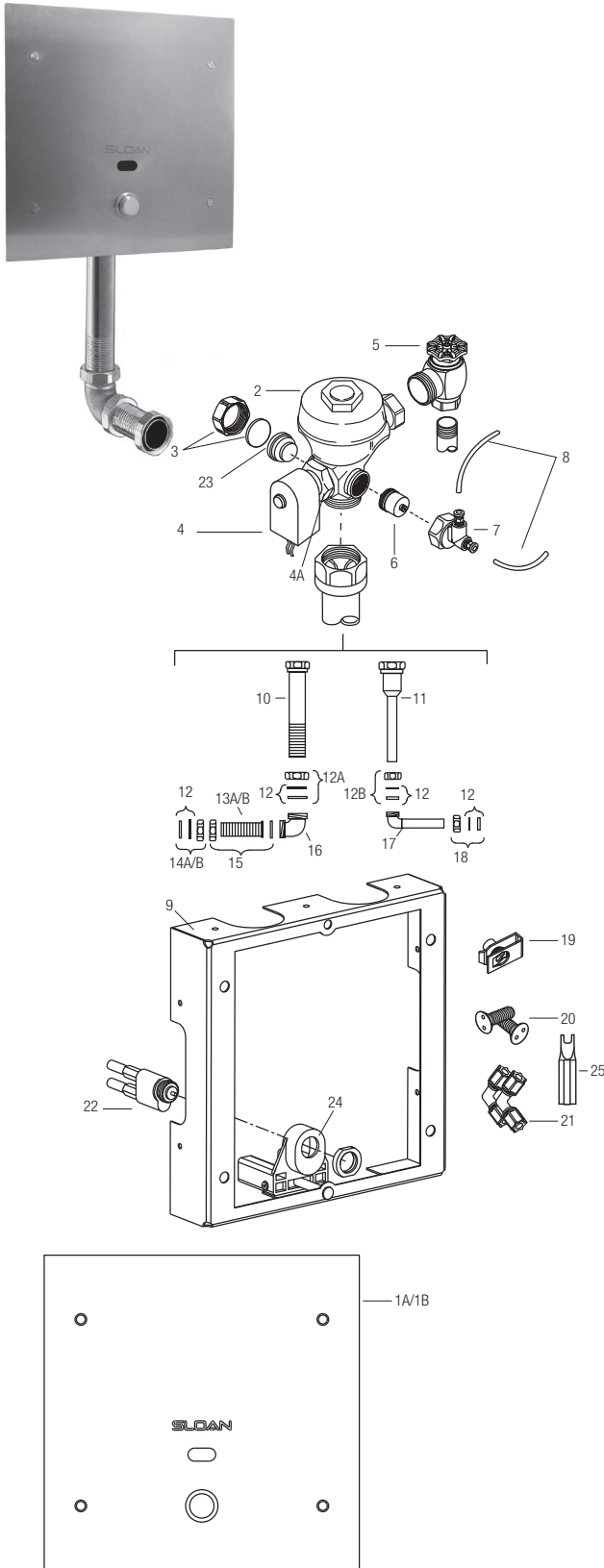

ROYAL® OPTIMA® ES-S TMO WITH SWB PARTS LIST

Item No.	Code No.	Part No.	Description
1A.	—	WB-55-A	Wall Box Cover Plate Assembly (Model 152)
1B.	—	WB-60-A	Wall Box Cover Plate Assembly (Model 195)
2.	‡	—	Valve Assembly
3.	3301093	A-1013-A	Concealed Valve Handle Cap RB
4.	0305331	EL-138-2	RB Concealed 24V Solenoid Assembly
4A.	3305043	EL-128-A	Actuator Cartridge Assembly Only
5.	‡	H-730-A	RB Bak-Chek® Control Stop
6.	3318001	HY-83-A	Actuator Cartridge
7.	3318005	HY-109-A-1	Valve Actuator Assembly
8.	0318117	HY-30	1/4" (6 mm) x 48" (1219 mm) Connecting Tubes
9.	3325215	—	Wall Box Assembly
10.	‡	V-500-AA	1-1/2" (38 mm) Vacuum Breaker Assembly RB (Model 152)
11.	‡	V-500-AA	3/4" (19 mm) Vacuum Breaker Assembly RB (Model 192)
12.	SEE SLIP JOINT GASKETS AND RINGS TABLE BELOW		
12A.	0306088	F-2-AT	1-1/2" (38 mm) Slip Joint Coupling Assembly RB (Model 152)
12B.	0306054	F-2-AW	3/4" (19 mm) Slip Joint Coupling Assembly RB (Model 192)
13A.	‡	F-110	1-1/4" (32 mm) Outlet Tube Flanged and Scored (Model 152)
13B.	‡	F-100	1-1/2" (38 mm) Outlet Tube Flanged and Scored (Model 152)
14A.	0306059	F-2-AU	1-1/4" (32 mm) Slip Joint Coupling Assembly RB (Model 152)
14B.	0306088	F-2-AT	1-1/2" (38 mm) Slip Joint Coupling Assembly RB (Model 152)
15.	0306091	F-2-A	1-1/2" (38 mm) Coupling with S-21 Gasket (Model 152)†
16.	0206146PK	F-21	1-1/2" (38 mm) Double Male Slip Joint Elbow
17.	0306366	F-15-A	ELL with 3/4" (19 mm) Tail (Model 195)†
18.	0306054	F-2-AW	3/4" (19 mm) Slip Joint Coupling
19.	0334017	WB-18	U-Type Nuts (4) 1/4-20
20.	0334024PK	WB-49	Tamper Resistant Screws (4) 1/4-20 x 1-1/2
21.	—	HY-126	Elbow Fitting (2) (included in WB-54A Kit)
22.	0318123	HY-71-A	Hydraulic Actuator Assembly
23.	0305190PK	EL-190-A	Handle Adapter Assembly
	3388015	H-1015-A	Flow Control Kit (HEU Only) (not Shown)
	3334001	WB-1001-A	Override Button Repair Kit (not shown)
	0334033	WB-54-A	Small Wall Box Mntg Hardware Kit (not shown)
24.	33753009	WB-1002-A	Override Holder Repair Kit
25.	0334009PK	WB-36-A	Spanner Bit #1/4

† "L" Dimension available between the lengths of 2" and 10%
‡ Part number varies with valve model variation; consult factory.

ITEM 12. SLIP JOINT GASKETS AND RINGS

Size	Code No.	Part No.	Description
1-1/2"	5306058	F-3	Red Friction Ring
	5322001	VBF-5	Black Slip Joint Gasket
	5319086	S-30	Flexible Seat
	0319079	S-21	Rigid Seat (rubber over brass)
1-1/2" x 1-1/4"	0396062	F-105	Slip Joint Gasket – Rigid
1-1/4"	5306057	F-3	Red Friction Ring
	5322176	VBF-5	Black Slip Joint Gasket
	0307052/5307052	G-21	Rigid Seat (rubber over brass)
1"	5306056	F-3	Red Friction Ring
	5306115	F-5	Black Slip Joint Gasket
3/4"	5306055	F-3	Red Friction Ring
	5306113	F-5	Black Slip Joint Gasket

Optima® Royal® ES-S TMO (SWB) Flushometer

TROUBLESHOOTING GUIDE

Urinals (EL-1500 Sensor)

When the sensor detects a user, a slow flashing red light appears in the sensor window. After eight (8) to ten (10) seconds, the light flashes rapidly to indicate that the sensor is armed. When the sensor no longer detects a user, the sensor immediately activates the solenoid valve after a 0.5 second delay.

Water Closets (EL-1500-L Sensor)

Detection and activation are the same as for the urinal EL-1500 sensor (ABOVE) except when the sensor no longer detects an user, the sensor activates the solenoid valve after a three (3) second delay.

The EL-1500 urinal and EL-1500-L closet self-adaptive sensors are equipped with a "Sentinel Flush" feature. These units automatically activate the solenoid every twenty-four (24) hours after the last user.

1. Valve does not function (red light does not flash when user steps in front of sensor).

- No power is being supplied to sensor. Ensure that the main power is turned "ON." Check transformer, leads and connections. Repair or replace as necessary.
- EL-1500-L Sensor is not operating. Replace the EL-1500-L Sensor.

2. Valve does not function (red light flashes when user steps in front of sensor).

INDICATOR: Red light stops flashing when user steps away and valve makes a "clicking" sound but does not flush.

- No water is being supplied to the valve. Make certain that the water supply is turned "ON" and the Control Stop is open. No power is being supplied to sensor. Ensure that the main power is turned "ON." Check transformer, leads and connections. Repair or replace as necessary.
- EL-128-A cartridge is fouled or jammed. Turn electronic power to valve "OFF" (failure to do so could result in damage to the solenoid coil. Remove the solenoid operator from the valve and remove the EL-128-A cartridge. Clean and/or repair as necessary.

INDICATOR: The red light stops flashing when user steps away but the valve does NOT make a "clicking" sound and does NOT flush.

- EL-163-A solenoid shaft assembly is fouled or jammed. Turn electronic power to valve "OFF" (failure to do so could result in damage to the solenoid coil). Remove EL-101 or EL-166 nut from the solenoid operator. Remove the coil from the solenoid operator. Use a spanner wrench or pliers to remove the EL-163-A solenoid shaft assembly from valve. Clean and/or replace as necessary. Be sure to replace plunger spring when reassembling Solenoid Shaft Assembly.

INDICATOR: The red light flashes three (3) short flashes, three (3) long flashes then three (3) short flashes ("S-O-S") and continues to repeat this cycle even when user steps out of the sensor's detection range.

- EL-1500-L Sensor wiring connections are incorrect. Rewire Sensor to valve. One solenoid lead connects to the "TO VALVE" connection on Sensor. One transformer lead connects to the "24 VAC IN" connection on Sensor. Second solenoid lead and second transformer lead connect together.
- Wiring to Sensor is ground shorted. Find short in wiring circuit and correct.
- EL-165-2 solenoid coil is burnt out or coil is not connected to solenoid plunger shaft. Reinstall or replace coil as necessary.

3. Volume of water is insufficient to adequately siphon fixture.

- Control Stop is not open wide enough. Adjust control stop for desired water delivery.
- Low Consumption unit is installed on Water Saver or Conventional fixture. Replace Diaphragm component parts of valve with kit that corresponds to appropriate flush volume of fixture.
- Inadequate water volume or pressure available from supply. Increase pressure or supply (flow rate) to the valve. Consult factory for assistance.

4. Length of flush is too long (long flushing) or valve fails to shut off.

- Water Saver valve is installed on Low Consumption fixture. Replace Diaphragm component parts of valve with kit that corresponds to appropriate flush volume of fixture.
- Relief valve in diaphragm is not seated properly or bypass hole in diaphragm is clogged. Disassemble inside Diaphragm component parts and wash parts thoroughly. Replace worn parts if necessary.

5. Water splashes from fixture.

- Supply flow rate is more than necessary. Adjust Control Stop to meet flow rate required for proper cleansing of the fixture.

6. Leakage occurring at the Push Button (Concealed models only).

- Damaged or worn seals or lime build up in the actuator cartridge. Replace with new HY-32-A cartridge.

7. The flushometer does not flush or flushes only once and will not flush a second time when the button is pushed (Concealed models only).

- The plunger is lodged in the actuator cartridge or the plunger by-pass hole is clogged. Remove the actuator housing and cartridge from the flushometer. Clean under running water. If cartridge parts are worn, deteriorated or limed up and problem persists after cleaning, replace with new HY-83-A cartridge.
 - Turn off water at the control stop.
 - Unscrew the housing coupling nut from the flushometer.
 - Remove the actuator housing from the flushometer. The tubing connections can be left intact.
 - Remove the actuator cartridge from the flushometer body. Care should be taken so that upon removal the actuator does not abruptly separate due to spring compression within. If the actuator cartridge is lodged in the body cavity, grip the exposed portion gently with a pair of channel lock pliers and rotate back and forth to loosen the "O" ring seal.
 - Separate the actuator housing to reveal the spring and plunger.
- Plastic Tubing Installed Incorrectly. Install Plastic Tubing Correctly.

8. The flushometer does not flush and a small amount of leakage is visible below the valve (Concealed models only).

- Foreign material lodged in the cartridge. Remove the cartridge and inspect for foreign material. Clean under running water.
- Damaged or worn seals or lime build up in the actuator cartridge. Replace with new HY-32-A cartridge.
 - Remove the button or actuator assembly from the wall or fixture.
 - Disassemble the flange or button assembly from the actuator body.
 - Unscrew the cartridge from the actuator body. Note: The metal push button was designed to be vandal-proof and thus requires removal from the wall for servicing.
- Plastic Tubing installed incorrectly. Install Plastic Tubing Correctly.

CARE AND CLEANING INSTRUCTIONS

DO NOT USE abrasive or chemical cleaners to clean flushometers or sensor that may dull the luster and attack the chrome or special decorative finishes. Use **ONLY** mild soap and water, then wipe dry with a clean towel or cloth.

When cleaning the bathroom tile, protect the flushometer from any splattering of cleaner. Acids and cleaning fluids can discolor or remove chrome plating.

**When assistance is required, please contact
Sloan Technical Support at: 1-888-SLOAN-14 (1-888-756-2614).**

Optima® Royal® ES-S SWB Flushometer

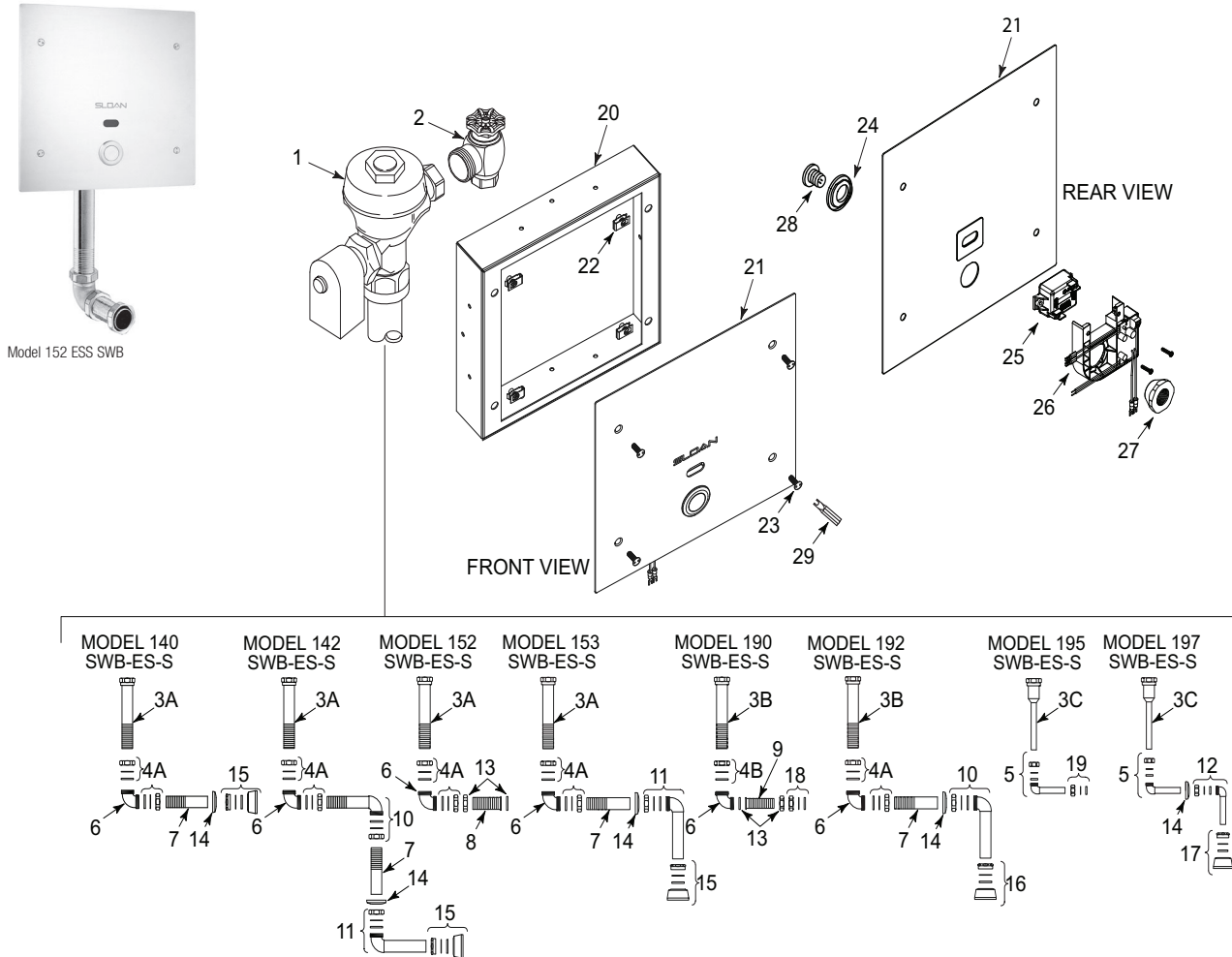

Item No.	Part No.	Description	Item No.	Part No.	Description
1.	‡	Valve Body – Solenoid Operated	19.	F-2-AW	3/4" (19 mm) Slip Joint Coupling RB
2.	H-730-A	Bak-Chek® Control Stop	20.	WB-3	Wall Box Frame
3A.	V-500-AA	1-1/2" (38 mm) x 11-1/2" (292 mm) Vacuum Breaker Assembly RB (Models 140 ES-S & 152 ES-S)	21.	WB-47	Access Panel
	V-500-AA	1-1/2" (38 mm) x 6" (152 mm) Vacuum Breaker Assembly RB (Model 142 ES-S)	22.	WB-18	U-Type Nuts (4)
	V-500-AA	1-1/2" (38 mm) x 7-1/2" (191 mm) Vacuum Breaker Assembly RB (Model 153 ES-S)	23.	WB-49	Tamper Resistant Screws (4)
3B.	V-500-AA	1-1/2" (32 mm) x 11-1/2" (292 mm) Vacuum Breaker Assembly RB (Models 190 ES-S & 192 ES-S)	24.	—	Bezel
3C.	V-500-AA	3/4" (19 mm) x 10-1/2" (267 mm) Vacuum Breaker Assembly RB (Models 195 ES-S & 197 ES-S)	25.	EL-1500-L	Sensor (Water Closet)
4A.	F-2-AA	1-1/2" (38 mm) Slip Joint Coupling RB (Set of Two)		EL-1500	Sensor (Urinal)
4B.	F-2-A	1-1/2" (38 mm) Slip Joint Coupling RB	26.	EL-630-A	Sensor Retainer and Circuit Board Assembly
5.	F-15-A	ELL with 3/4" (19 mm) Tail RB (Models 195 ES-S & 197 ES-S)	27.	—	Back Nut
6.	F-21	1-1/2" (38 mm) Double Slip Elbow	28.	EL-438	Override Button
7.	F-102	1-1/2" (38 mm) Outlet Tube CP†	29.	WB-36	Spanner Bit #1/4
8.	F-100	1-1/2" (38 mm) Outlet Tube RB†			
9.	F-110	1-1/4" (32 mm) Outlet Tube RB†			
10.	F-25-A	1-1/4" (32 mm) Elbow Assembly†			
11.	F-25-A	1-1/2" (38 mm) Elbow Assembly CP (Model 153 ES-S)			
12.	F-15-A	ELL with 3/4" (19 mm) Tail CP (Model 197 ES-S)			
13.	F-2-A	1-1/2" (38 mm) Coupling with S-21 Gasket			
14.	F-7	Flange			
15.	F-5-A	1-1/2" (38 mm) Spud Coupling Assembly CP			
16.	F-5-A	1-1/4" (32 mm) Spud Coupling Assembly CP			
17.	F-5-A	3/4" (19 mm) Spud Coupling Assembly CP			
18.	F-2-A-U	1-1/4" (32 mm) Slip Joint Coupling RB			

† "L Dimension" only available between 2" & 10 3/4"
‡ Part number varies with valve model variation; consult factory.

NOTE: The information contained in this document is subject to change without notice.

Optima® Royal® ES-S SWB Flushometer

NOTE: Upon detection of the user, the red indicator light flashes slowly for a period of eight seconds. When the user leaves the detection range, the indicator light flashes rapidly and the Sensor initiates the flush sequence. Then the indicator light stops flashing and the valve flushes. The valve will flush after a three-second delay.

1. PROBLEM: Valve does not function (red light does not flash when user steps in front of sensor).

CAUSE: No power is being supplied to sensor.

SOLUTION: Ensure that the main power is turned "ON."
Check transformer, leads and connections.
Repair or replace as necessary.

CAUSE: EL-1500 (Urinal installations) or EL-1500-L (Closet installations) Sensor is not operating.

SOLUTION: Replace EL-1500 or EL-1500-L Sensor.

2. PROBLEM: Valve does not function (red light flashes when user steps in front of Sensor).

INDICATOR: Red light stops flashing when user steps away and valve makes a "clicking" sound but does not flush.

CAUSE: No water is being supplied to the valve.

SOLUTION: Make certain that water supply is turned "ON" and the Control Stop is open.

CAUSE: EL-128-A cartridge is fouled or jammed.

SOLUTION: Turn electronic power to valve "OFF" (failure to do so could result in damage to the solenoid coil). Remove the solenoid operator from the valve and remove the EL-128-A cartridge. Clean and/or repair as necessary.

INDICATOR: The red light stops flashing when user steps away but the valve does NOT make a "clicking" sound and does NOT flush.

CAUSE: EL-163-A solenoid shaft assembly is fouled or jammed.

SOLUTION: Turn electronic power to valve "OFF" (failure to do so could result in damage to the solenoid coil). Remove EL-101 or EL-166 nut from the solenoid operator. Remove the coil from the solenoid operator. Use a spanner wrench or pliers to remove the EL-163-A solenoid shaft assembly from valve. Clean and/or replace as necessary. Be sure to replace plunger spring when reassembling Solenoid Shaft Assembly.

INDICATOR: The red light flashes three (3) short flashes, three (3) long flashes then three (3) short flashes ("S-O-S") and continues to repeat this cycle even when user steps out of the sensor's detection range.

CAUSE: Sensor wiring connections are incorrect.

SOLUTION: Refer to Step 10 of this Installation Instructions for proper wiring.

CAUSE: Wiring to Sensor is ground shorted.

SOLUTION: Find short in wiring circuit and correct.

CAUSE: EL-165-2 solenoid coil is burnt out or coil is not connected to solenoid plunger shaft.

SOLUTION: Reinstall or replace coil as necessary.

3. PROBLEM: Volume of water is insufficient to adequately siphon fixture.

CAUSE: Control Stop is not open wide enough.

SOLUTION: Adjust control stop for desired water delivery.

CAUSE: Low Consumption unit is installed on Water Saver or Conventional fixture.

SOLUTION: Replace Diaphragm component parts of valve with kit that corresponds to appropriate flush volume of fixture.

CAUSE: Inadequate water volume or pressure available from supply.

SOLUTION: Increase pressure or supply (flow rate) to the valve. Consult factory for assistance.

4. PROBLEM: Length of flush is too long (long flushing) or valve fails to shut off.

CAUSE: Water Saver valve is installed on Low Consumption fixture.

SOLUTION: Replace Diaphragm component parts of valve with kit that corresponds to appropriate flush volume of fixture.

CAUSE: Relief valve in diaphragm is not seated properly or bypass hole in diaphragm is clogged.

SOLUTION: Disassemble inside Diaphragm component parts and wash parts thoroughly. Replace worn parts if necessary.

5. PROBLEM: Water splashes from fixture.

CAUSE: Supply flow rate is more than necessary.

SOLUTION: Adjust Control Stop to meet flow rate required for proper cleansing of the fixture.

If further assistance is required, please contact Sloan
Technical Support at:

1-888-SLOAN-14 (1-888-756-2614).

!!! IMPORTANT — Control Stop Setting !!!

Never open Control Stop to where the flow from the valve exceeds the flow capability of the fixture. In the event of a valve failure, the fixture must be able to accommodate a continuous flow from the valve.

Optima® Royal® ES 24V/120V Exposed Flushometer

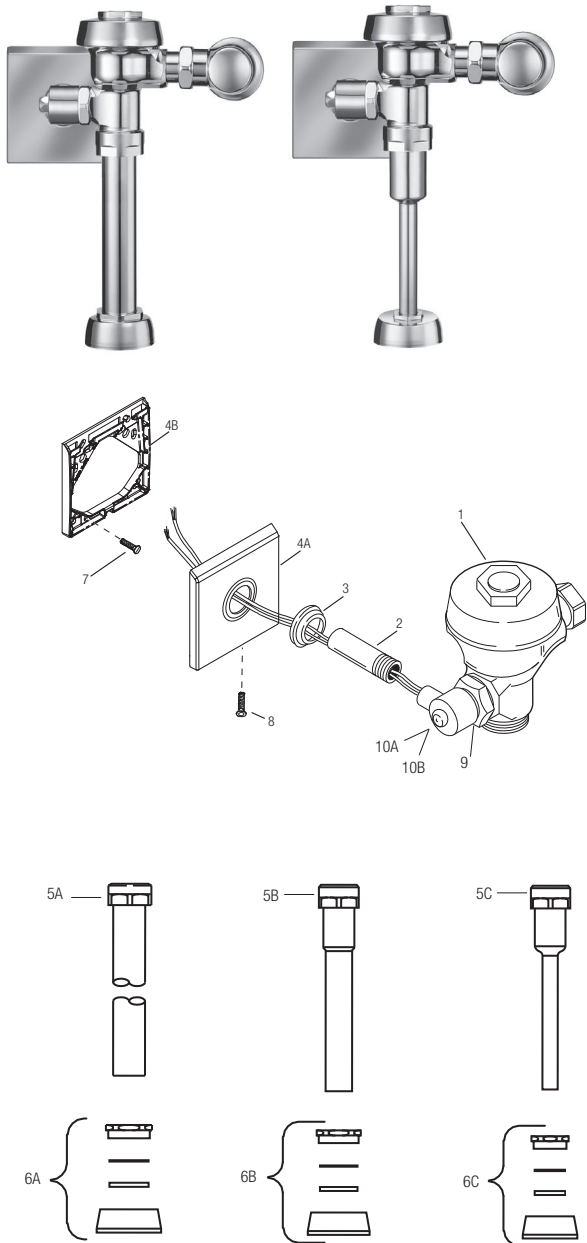

ROYAL® OPTIMA® ES 24/120V EXPOSED FLUSHOMETER PARTS LIST

Item No.	Code No.	Part No.	Description
1.	‡		Solenoid Activated Valve Assembly
2.	0306249PK	F-15	Tail Assembly
3.	0345150	EL-431-A	Flange Assembly
4A.	3305105	EL-625-A	Cover Plate w/Mounting Hardwar (Closet only) (Includes EL-549 Mounting Plastic plate)
4B.	0305251PK	EL-549	Exposed Closet Mounting Plate
5A.	—	V-600-AA	1-1/2" (38 mm) Vacuum Breaker Assembly CP (Models 110/111, 115, and 116)
5B.	—	V-600-AA	1-1/4" (32 mm) x 9" (229 mm) Vacuum Breaker Assembly CP (Model 180 ES-S)
5C.	—	V-600-AA	3/4" (19 mm) x 9" (229 mm) Vacuum Breaker Assembly CP (Model 186 ES-S)
6A.	0306146	F-5-AT	1-1/2" (38 mm) Spud Coupling Assembly CP (Models 110/111, 115, and 116)
6B.	0306140	F-5-AU	1-1/4" (32 mm) Spud Coupling Assembly CP (Model 180)
6C.	0306125	F-5-AW	3/4" (19 mm) Spud Coupling Assembly CP (Model 186)
6D.	SEE SLIP JOINT GASKETS AND RINGS ON TABLE BELOW		
7.	‡		Screws (Flat Head Slotted #6/32)
8.	5305100	EL-674	Wall Plate Screw Kit (#6/32 x 15.87 mm) (6 per kit)
9.	3305043	EL-128-A	Actuator Cartridge
10A.	0305329	EL-124-2	CP 24V Solenoid Assembly Only
10B.	0305328	EL-124-1	CP 120V Solenoid Assembly Only
	3305045	EL-1028-A	Solenoid Assembly (24V) w/ Cartridge Assembly
	3305044	EL-1029-A	Solenoid Assembly (120V) w/ Cartridge Assembly
12.	3325814	EBV-1017-A	CP Valve Handle Cap
14.	3302306	B-51-A	Triple Seal Handle Repair Kit
15.	3345080	EL-126-A	ESS to TMO Retrofit Conversion Kit (Exposed*)
*	3388015	H-1015-A	Flow Control Kit (HEU Only) (not Shown)
*	0305163	EL-172-A	Electric Push Button Assembly (Optional)

‡ Part number varies with valve model variation; consult factory.
* Not shown

ITEM 6D. SLIP JOINT GASKETS AND RINGS

Size	Code No.	Part No.	Description
1-1/2"	5306058	F-3	Red Friction Ring
	5322001	VBF-5	Black Slip Joint Gasket
	5319086	S-30	Flexible Seat
	0319079	S-21	Rigid Seat (rubber over brass)
1-1/2" x 1-1/4"	0396062	F-105	Slip Joint Gasket – Rigid
1-1/4"	5306057	F-3	Red Friction Ring
	5322176	VBF-5	Black Slip Joint Gasket
	0307052/5307052	G-21	Rigid Seat (rubber over brass)
1"	5306056	F-3	Red Friction Ring
	5306115	F-5	Black Slip Joint Gasket
3/4"	5306055	F-3	Red Friction Ring
	5306113	F-5	Black Slip Joint Gasket

Solenoid Activated Royal® Model Flushometer for floor mounted or wall hung fixtures. Model "ES" Flushometers are activated remotely by an electric push button (not included). Royal "ES" Flushometers offer solutions for installations that require automatic, remote or other Flushometer control requirements.

SMOOTH® Hardwired Flushometer Side-Mount-Operator-Over-The-Handle

AC powered, sensor activated retrofit unit for exposed closet and urinal flushometers.

PARTS LIST

Item No.	Code No.	Part No.	Description
1.	3305201	EL-600-A	Side Mount Operator for Water Closets (Toilets) and Urinals
2.	3345085	EL-612-A	Wall Flange Hardware Mounting Kit

ACCESSORY TRANSFORMERS

—	0345095	EL-386	120 VAC/6 VAC, 50/60 Hz (3 VA) Plug-in (will operate 1 unit)
—	0345125	EL-451	120 VAC/6 VAC, 50/60 Hz (25 VA) Box Mount (will operate up to 8 units)

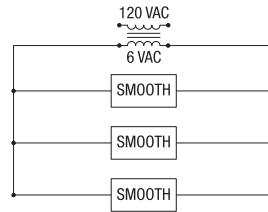

One EL-386 Transformer serves one (1) Closet/Urinal flushometer.
One EL-451 Transformer serves up to eight (8) Closet/Urinal flushometers.

ADJUSTMENT PROCEDURES

Mode A

The SMOOTH unit may be reset to normal range by fully pressing and holding in the Override Handle until the Red LED light in the Sensor Window illuminates. Then immediately release the Override Handle.

Mode B

The SMOOTH unit may be set to reduced range for closet applications by pressing and holding in the Override Handle until the Red LED light in the Sensor Window flashes a slow long blinking light. Then immediately release the Override Handle.

Mode C (Urinal Only)

The SMOOTH unit may be set to reduced range by pressing and holding in the Override Handle until the Red LED light in the Sensor Window displays a rapid on and off blinking light. Then immediately release the Override Handle.

CARE AND CLEANING OF CHROME AND SPECIAL FINISHES

DO NOT USE abrasive or chemical cleaners to clean flushometers as they may dull the luster and attack the chrome or special decorative finishes. Use **ONLY** mild soap and water, then wipe dry with clean cloth or towel.

While cleaning the bathroom tile, the flushometer should be protected from any splattering of cleaner. Acids and cleaning fluids can discolor or remove chrome plating.

**When assistance is required, please contact
Sloan Technical Support at: 1-888-SLOAN-14 (1-888-756-2614).**

EL-750/EL-700 Hardwired Flushometers

EL-750/Hardwired
Dual-flush Side Mount

EL-700/Hardwired
Single-flush Side Mount

VAC Power Requirement: Transformer 6 VAC 0.5 mA per unit

Sloan Transformers:

EL-386 – 120 VAC/ 6 VAC Plug-in Transformers

EL-451 – 120 VAC/6 VAC 25 VA Box Style Transformers

NOTE: One (1) Hardwire Flushometer per each EL-386 Transformer and six (6) Hardwire Flushometers per each EL-451 Transformer



Hardwired, sensor-activated, retrofit unit for exposed, dual-flush and single-flush closet and single-flush urinal.

Wiring Diagram

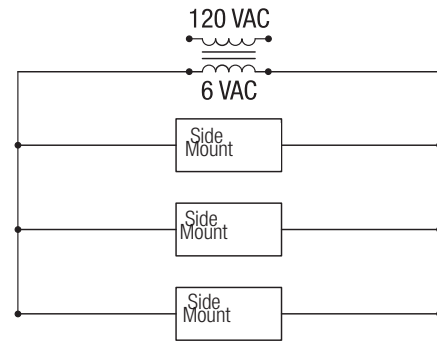

EBV-505-A
Dual-flush
Sleeve Assembly
(Supplied with Hex
Wrench)



EL-750
Dual-flush
Side Mount

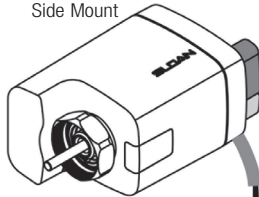

Battery Compartment
Hex Wrench 2.5 mm

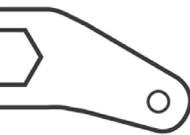
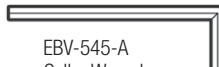

EL-700
Single-flush
Side Mount

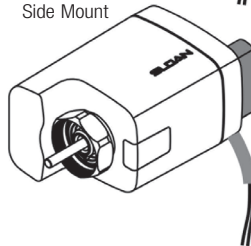

WES-46 DFSM Wall Plate

EBV-570-A
Single-flush
Sleeve Assembly
(Supplied with Hex
Wrench)

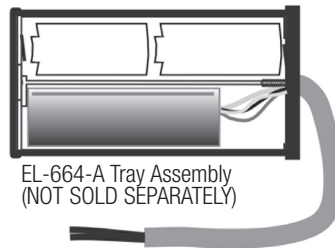

EL-612-A Wall Flange
Mounting Kit

EL-750/EL-700 Hardwired Flushometers

TROUBLESHOOTING GUIDE

1. RED LED continuously flashes when target is present.

Check voltage coming from transformer.

2. RED LED flashes 4 times after a target has been present for 8 seconds. RED LED flashes once when a target is NOT present.

Check voltage coming from transformer.

3. RED LED flashes continuously after calibration.

The unit has failed to calibrate. The optics window is obscured. Remove power, clean window and remove any objects (barrels, toolboxes, etc.) within close proximity of unit. Repeat power-up sequence (See TRANSFORMER START_UP ACTIVATION for power-up sequence). If unit fails, consult Sloan Technical Support.

CARE AND CLEANING OF CHROME AND SPECIAL FINISHES

DO NOT USE abrasive or chemical cleaners (including chlorine bleach) to clean side mount unit or flushometer that may dull the luster and attack the finish. Use **ONLY** mild soap and water, then wipe dry with clean cloth or towel.

While cleaning the bathroom tile, protect the side mount unit from any splattering of cleaner. Acids and cleaning fluids can discolor or remove chrome plating.

DO NOT USE abrasive or chemical cleaners (including chlorine bleach) to clean sensor window that may distort or ruin the sensor.

**When assistance is required, please contact
Sloan Technical Support at: 1-888-SLOAN-14 (1-888-756-2614).**

TRANSFORMER START-UP ACTIVATION

Turn on transformer power and wait for 10 seconds. Remove sticker from sensor window. The Side Mount unit will “wake up” when sticker is removed from sensor window. Please ensure this is the last step in the installation process and unless the target is a permanent fixture in the sensor’s environment (i.e. a wall or stall door) it must be removed from the view of the sensor. There is a three minute delay to calibration to allow the installer to clear from the view of the sensor. The Side Mount unit calibrates to the surrounding environment once sticker is removed (with three minute delay to allow installer to clear from the view of the sensor). Remove all non-permanent articles and step away from the sensor view until the one (1) flush activation verifies calibration is complete. The unit will exhibit an LED flash pattern as follows:

- GREEN and RED LED flash once, GREEN LED flashes 5 times
- 150 seconds of slow GREEN double flashes
- 10 seconds of fast GREEN double flashes
- 12-15 seconds of fast GREEN flashes (calibration)
- 3 slow GREEN LED flashes indicates calibration is done
- Normal Operation with one flush activation

After power off, re-power up will need three (3) minute delay to allow installer to clear from the view of the sensor.

SLOAN ECOS® Hardwired Flushometer

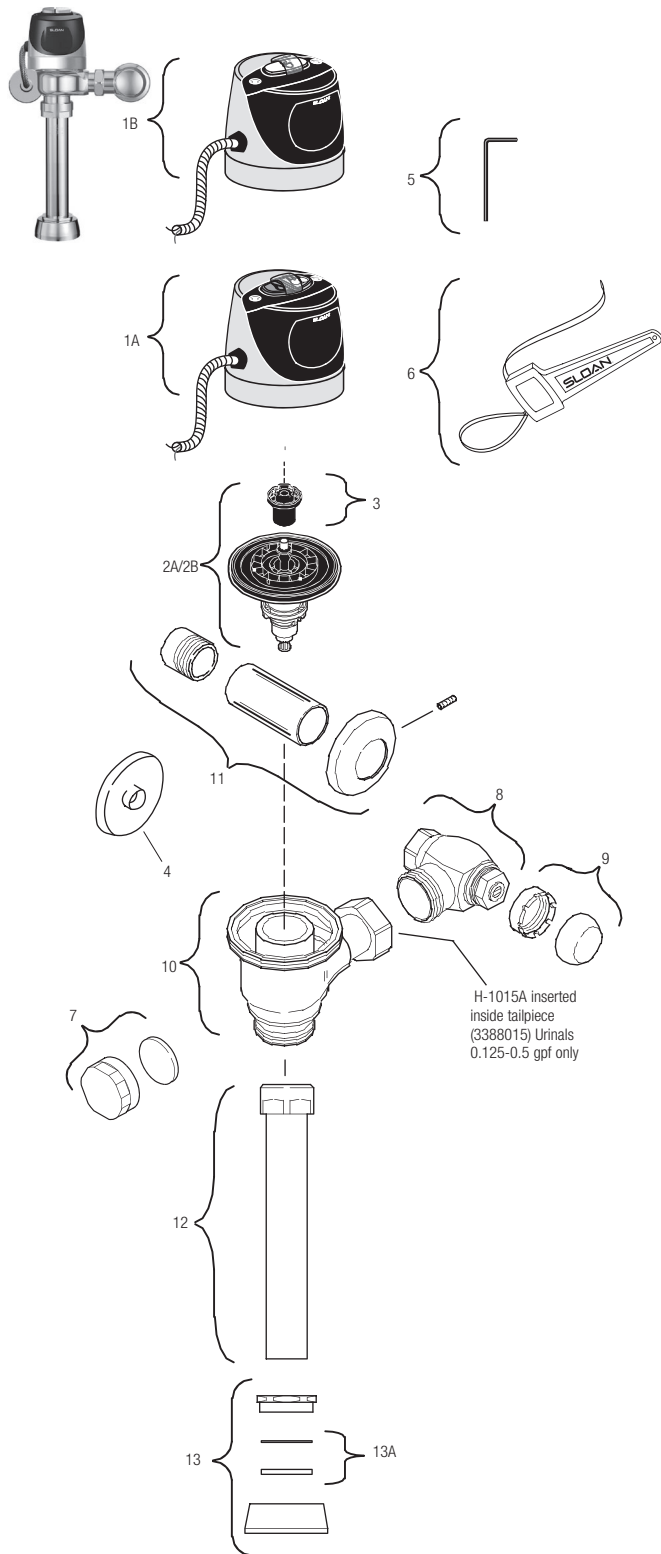

URINAL FLEX TUBE DIAPHRAGM ASSEMBLY



- 3325090** EBV-1025-A 0.125/0.25 gpf
- 3325003** EBV-1023-A 0.5 gpf

Sloan ECOS® Electronic Valve Models Feature Sloan's Exclusive Flex Tube Diaphragm for the ultimate in valve performance, reliability and chloramine resistance.

PARTS LIST

Item No.	Code No.	Part No.	Description
Items Included with the RESS Retrofit and Complete Sloan ECOS® Hardwire Valves Only			
1A.	0325304PK	WES-56A	Sloan ECOS® Electronic Hardwire Dual Flush Assembly CP
	0325332PK	EBV-332A	Sloan ECOS® Electronic Hardwire 1.28 gpf(4.8 Lpf) Single Flush Assembly
1B.	0325344PK	EBV-344A	Sloan ECOS® Electronic Single-Flush Assembly Urinal
1C.	0325402	EBV-393-A	Sloan ECOS® Electronic Single-Flush Assembly Urinal 0.125 gpf
2A.	3325001	EBV-1020-A	1.6 gpf/6.0 Lpf Closet Flex Tube Diaphragm Kit
2B.			See Chart Below
3.	5325122	EBV-95	Flush Volume Regulator (Green)
4.	3345085	EL-612-A	Solenoid Wall Flange
5.	0325159PK	EBV-137	7/64" Hex Wrench
6.	0305823	EBV-22	Strap Wrench
7.	3325814	EBV-1017-A	Handle Cap (RESS-C Retrofit Models only)
Items Included with the Complete Sloan ECOS® Hardwire Valves Only			
8.	3308386	H-700-A	1" (25 mm) Bak-Chek® Control Stop
9.	3308797	H-1010-A	Vandal Resistant Stop Cap
10.	0305381PK	EBV-36-A	Valve Body
11.	3308782	H-633-AA	1" (25 mm) Sweat Solder Kit
12.	3308782	V-600-AA	1½" (38 mm) x 10 ½" (254 mm) Vacuum Breaker (Model 110) (10" Outlet Tube)
		V-600-AA	1½" (38 mm) x 23" (584 mm) Vacuum Breaker (Model 115)
	0393049	V-600-AA	1½" (38 mm) x 26" (660 mm) Vacuum Breaker (Model 116)
13.	0306146	F-5-AT	1½" Spud Coupling Assembly (Models 111, 115, and 116)
13A.	SEE SLIP JOINT GASKETS AND RINGS TABLE BELOW		
‡ Part number varies with valve model variation; consult factory. 18" Steel Cable included w/HW units. The EBV-1020-A Kit is supplied with multiple Flush Volume Regulators. The installer must use the correct Regulator when installing the kit.			
VAC Power Requirement: Transformer 6 VAC 0.5 mA per unit			
Sloan Transformers:			
EL-386 – 120 VAC/ 6 VAC Plug-in Transformers (not shown)			
EL-451 – 120 VAC/6 VAC 25 VA Box Style Transformers (not shown)			
Note: One (1) Sloan ECOS® Hardwire per each EL-386 Transformer and six (6) Sloan ECOS® Hardwire per each EL-451 Transformer. 18 gauge wire required.			
ITEM 15A. SLIP JOINT GASKETS AND RINGS			
Size	Code No.	Part No.	Description
1-1/2"	5306058	F-3	Red Friction Ring
	5322001	VBF-5	Black Slip Joint Gasket
	0319086/5319086	S-30	Flexible Seat
1-1/2" x 1-1/4"	0319079	S-21	Rigid Seat (rubber over brass)
	0396062	F-105	Slip Joint Gasket – Rigid
1-1/4"	5306057	F-3	Red Friction Ring
	5322176	VBF-5	Black Slip Joint Gasket
	0307052/5307052	G-21	Rigid Seat (rubber over brass)
1"	5306056	F-3	Red Friction Ring
	5306115	F-5	Black Slip Joint Gasket
3/4"	5306055	F-3	Red Friction Ring
	5306113	F-5	Black Slip Joint Gasket

SLOAN ECOS® Hardwired Flushometer

RANGE ADJUSTMENT (ADJUST ONLY IF NECESSARY)

The Sloan ECOS® Hardwire flushometer has a factory set sensing range:

Water Closet Models – 22" (559 mm) to 42" (1067 mm)

Urinals Models – 15" (381 mm) to 30" (762 mm)

The factory setting should be satisfactory for most installations.

If the range is too short (i.e., not picking up the user) or too long (i.e., picking up opposite wall or stall door) the range can be adjusted.

NOTE: Water does not have to be turned off to adjust range.

Loosen the two screws on top of the unit. Remove the override button assembly. Remove the rubber plug from top of electronic sensor module to uncover the potentiometer to adjust.

Range Adjustment Procedure

For the first ten (10) minutes of operation, a visible light flashes in the sensing window of the Sloan ECOS® Hardwire flushometer when a user is detected. The visible light feature can be reactivated after ten (10) minutes by turning the power off and on. Check the range by stepping toward the unit until the light flashes, indicating the sensor's maximum detection limit. Adjust the range potentiometer screw located on top of the sensor module a few degrees **CLOCKWISE** to increase the range or a few degrees **COUNTER-CLOCKWISE** to decrease the range. Repeat this adjustment until the desired range is achieved.

Always determine the sensing range with metal cover and lens window installed on top of the unit.

IMPORTANT: Adjust in small increments only! Range potentiometer adjustment screw rotates only $\frac{3}{4}$ of a turn; DO NOT over-rotate.

When range adjustment is satisfactory, replace the rubber plug. Reinstall override button and tighten the two screws on top of the unit.

TROUBLESHOOTING GUIDE

1. Sensor flashes continuously only when user steps within range.

A. Unit in start-up mode; no problem. This feature is active for the first ten (10) minutes of operation.

2. Valve DOES NOT flush; sensor does not picking up the user.

A. Range too short; increase the range.

3. Valve DOES NOT flush; sensor picking up opposite wall or surface, or only flushes when someone walks by. Light flashes continuously for first 10 minutes even with no one in front of the sensor.

A. Range too long; shorten the range.

4. Valve DOES NOT flush even after adjustment.

A. Range adjustment potentiometer set at full "max" or full "min" setting. Readjust potentiometer away from full "max" or "min" setting.

B. Electronic sensor module issue; replace the electronic sensor module.

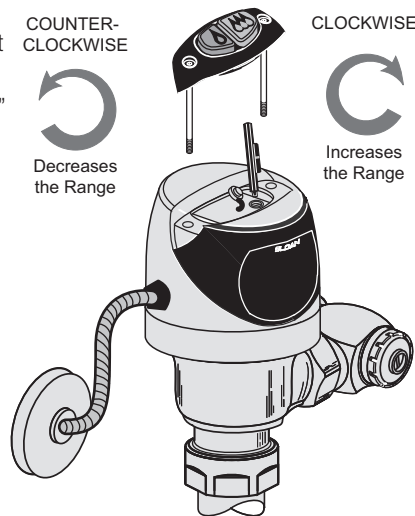

TROUBLESHOOTING GUIDE (CONTINUED)

5. Valve DOES NOT Shut Off.

A. Bypass orifice in diaphragm is clogged with dirt or debris, or bypass is clogged by an invisible gelatinous film due to "over-treated" water. Remove Flex Tube diaphragm and wash under running water.

NOTE: Size of orifice in the bypass is of utmost importance for the proper metering of water by the valve. **DO NOT ENLARGE OR DAMAGE THIS ORIFICE.** Replace Flex Tube diaphragm if cleaning does not correct the problem.

B. Dirt or debris fouling stem or Flex Tube diaphragm. Remove Flex Tube diaphragm and wash under running water.

C. O-ring on stem of Flex Tube diaphragm is damaged or worn. Replace O-ring if necessary.

D. Electronic sensor module issue; replace sensor module.

6. Not enough water to the fixture to flush properly.

A. The wrong flush volume regulator was installed in flex tube diaphragm kit. Install the correct regulator.

B. Wrong Sloan ECOS Hardwire model installed; i.e., 1.6 gpf model installed on 3.5 gallon closet fixture.

C. Enlarged bypass in diaphragm. Replace the Flex Tube diaphragm.

D. Control stop not adjusted properly. Readjust control stop.

E. Inadequate volume or pressure at supply. Increase water pressure or supply (flow) to valve. Consult factory for assistance.

7. Too much water to fixture.

A. The wrong flush volume regulator was installed in Flex Tube diaphragm kit. Install the correct regulator.

B. Control stop not adjusted properly. Readjust the control stop.

C. Wrong Sloan ECOS Hardwire model installed; i.e., 3.5 gpf. model installed on 1.6 gallon fixture. Replace with proper Sloan ECOS Hardwire model.

D. Dirt in diaphragm bypass. Clean under running water or replace Flex Tube diaphragm.

CARE AND CLEANING INSTRUCTIONS

DO NOT USE abrasive or chemical cleaners to clean flushometers that may dull the luster and attack the chrome or special decorative finishes. Use **ONLY** mild soap and water, then wipe dry with a clean towel or cloth.

When cleaning the bathroom tile, protect the flushometer from any splattering of cleaner. Acids and cleaning fluids can discolor or remove chrome plating.

When assistance is required, please contact

Sloan Technical Support at: 1-888-SLOAN-14 (1-888-756-2614).

TruFlush Hardwired/Battery Flushometer

Sensor Closet Flushometers

- TRF 8156 - 1.6 gpf
- TRF 8156 - 1.28 gpf
- TRF 8156 - 1.1 gpf

Sensor Urinal Flushometers

- TRF 8196 - 0.5 gpf
- TRF 8196 - 0.25 gpf
- TRF 8196 - 0.125 gpf

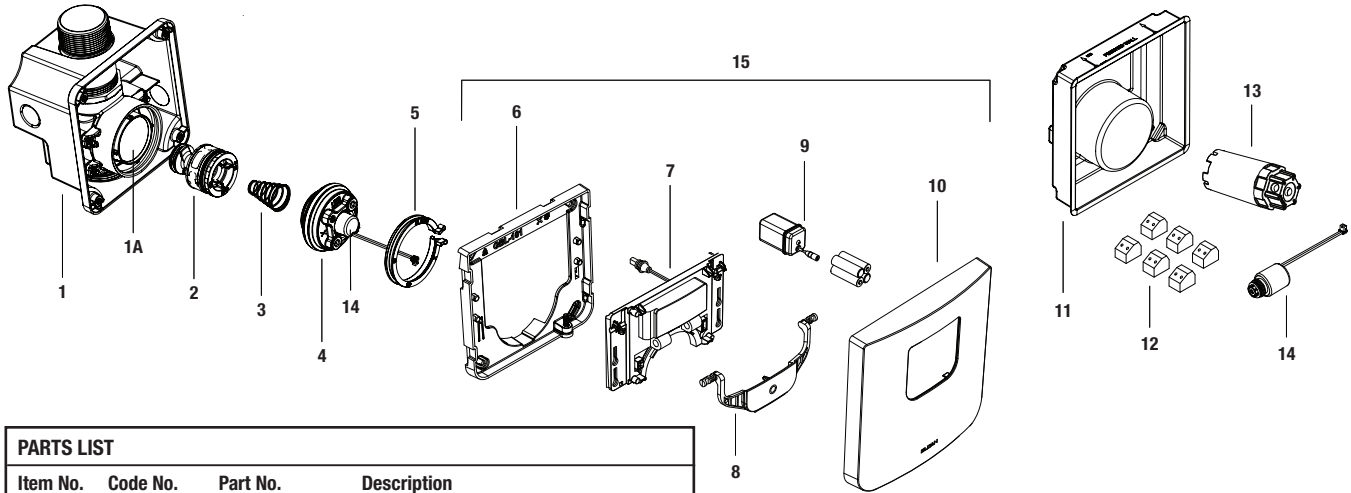

PARTS LIST			
Item No.	Code No.	Part No.	Description
1.	—	—	Valve Assembly with Box
1A.	0340085	GBL-66-A	Shut Off Sleeve (with O-Ring)
2.	See table to the right	—	Piston Assembly
3.	—	—	Conical Spring*
4.	See table on next page	—	Activation Assembly**
5.	3340011	GBL-1011-A	Safety Collar
6.	0340101	GBL-101	TRF Sensor Closet Wall Bracket
7.	—	—	TRF Sensor Assembly Repair Kit
8.	See table on next page	—	Override Button Only
9.	9103681PK	ELG-79	Battery Pack
10.	0340142	GBL-128	TRF Sensor Finished Wall Plate, CP †
11.	33400036	GBL-1036-A	Replacement Kit, Mud Guard Sensor (4 pack)
12.	3340033	GBL-88-A	Terminal Block Repair Kit (6)
13.	3340012	GBL-1012-A	Activation Assembly Tool
14.	See table on next page	—	Solenoid Repair Kit
15.	—	GBL-205-A	Finished Wall Plate and Sensor Assembly† (Includes items 6-10)

* Included with Piston Assembly. † Consult factory for alternate finishes.
 ** Includes Solenoid Repair Kit #14.

ITEM NO. 2 - SENSOR PISTON ASSEMBLY SELECTION GUIDE			
Code No.	Part No.	Description	Piston Color*
3340024	GBL-1024-A	1.6 gpf/6.0 Lpf Closet Piston Assembly (Washdown)	Orange
3340005	GBL-1005-A	1.6 gpf/6.0 Lpf Closet Piston Assembly	Green
3340082	GBL-1097-A	1.28 gpf/4.8 Lpf Closet Piston Assembly	Blue/Black
3340065	GBL-1090-A	1.1 gpf/4.2 Lpf Closet Piston Assembly	Burgundy/Black
3340007	GBL-1007-A	0.5 gpf/1.9 Lpf Urinal Piston Assembly	Red
3340008	GBL-1008-A	0.25 gpf/1.0 Lpf Urinal Piston Assembly	Burgundy
33400001	—	0.125 gpf/0.48 Lpf Urinal Piston Assembly	Red/Pink

* Colors may differ. Consult factory to confirm you have the correct Piston Assembly.

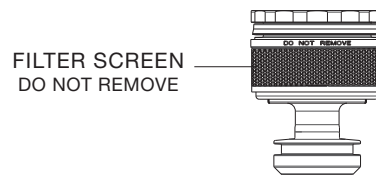

TRUFLUSH SENSOR PISTON
SEE CHART BELOW FOR MORE

ITEM NO. 2 - SENSOR PISTON IDENTIFICATION CHART

Flush Volume	1.6 gpf WD (India) Water Closet	1.6 gpf Water Closet	1.28 gpf Water Closet	1.1 gpf Water Closet	0.5 gpf Urinal	0.25 gpf Urinal	0.125 gpf Urinal
Piston Body	Orange with Screen	Green with Screen	Light Blue with Screen	Burgundy with Screen	Red with Screen	Burgundy with Screen	Red with Screen
Flow Control	Orange	Green	Black Cage	Black Cage	Red	Burgundy	Pink
Part Number	GBL-1024-A	GBL-1005-A	GBL-1097-A	GBL-1090-A	GBL-1007-A	GBL-1008-A	—
Code Number	3340024	3340005	3340082	3340065	3340007	3340008	33400001

TruFlush Hardwired/Battery Flushometer

ITEM NO. 4 - SENSOR ACTIVATION ASSEMBLY SELECTION GUIDE			
Code No.	Part No.	Description	Aspirator Retainer Color*
LEGACY STYLE CONNECTION - PRIOR TO DECEMBER 2021			
3340000	GBL-1000-A	1.6 gpf/6.0 Lpf Closet Activation Assembly	Green
3340001	GBL-1001-A	1.28 gpf/4.8 Lpf Closet Activation Assembly	Purple
3340002	GBL-1002-A	0.5 gpf/1.9 Lpf Urinal Activation Assembly	Red
3340003	GBL-1003-A	0.25 gpf/1.0 Lpf Urinal Activation Assembly	Burgundy
33400002	GBL-1069-A	0.125 gpf/0.48 Lpf Urinal Activation Assembly†	Pink
PIGTAIL STYLE CONNECTION - AFTER DECEMBER 2021			
33400049	GBL-1071-A	1.6 gpf/6.0 Lpf Closet Activation Assembly (Washdown)	Orange
33400048	GBL-1072-A	1.6 gpf/6.0 Lpf Closet Activation Assembly	Green
33400047	GBL-1073-A	1.28 gpf/4.8 Lpf Closet Activation Assembly	Purple
33400066	GBL-1094-A	1.1 gpf/4.2 Lpf Closet Activation Assembly	Grey
33400046	GBL-1074-A	0.5 gpf/1.9 Lpf Urinal Activation Assembly	Red
33400045	GBL-1075-A	0.25 gpf/1.0 Lpf Urinal Activation Assembly	Burgundy
33400055	GBL-1076-A	0.125 gpf/0.48 Lpf Urinal Activation Assembly	Pink

* Colors may differ. Consult factory to confirm you have the correct Activation Assembly.

† 0.125 gpf/0.48 Lpf Valve Components (Piston, Main Seat, and Activation Assembly) are NOT interchangeable with any other flush volume Valves.

ADDITIONAL PARTS		
Code No.	Part No.	Description
3340022	GBL-1022-A	Sensor TRF Finished Wall Plate and Button Assembly, CP (Items 8 & 10 on previous page).

IMPORTANT NOTE FOR 1.1 GPF FLUSHOMETERS & REPLACEMENT KITS

Sloan 1.1 gpf/4.2 Lpf ultra-high efficiency flushometers meets all applicable standards and requirements. However, with low flush volumes it is imperative that they only be used in conjunction with toilet fixtures and drain line systems designed to operate with adequate flow rates and volumes in order to effectively eliminate waste and move it out of the building. It is the responsibility of the user to ensure both of these conditions are met. Not doing so may void your warranty.

Sloan 1.1 gpf diaphragm and piston kits are designed as a replacement part for Sloan 1.1 gpf/4.2 Lpf flushometers only. They are not intended to be used as a means to reduce water consumption in flushometers with higher flush volumes such as 1.28 gpf/4.8 Lpf or 1.6 gpf/6.0 Lpf or higher. Using this kit in any manner other than with a Sloan 1.1 gpf flushometer may void your warranty.

NOTE: After December 2021, the Activation, Sensor, and Solenoid Assembly connections were changed to a pigtail style connector.

CONNECTION TYPES



PIGTAIL

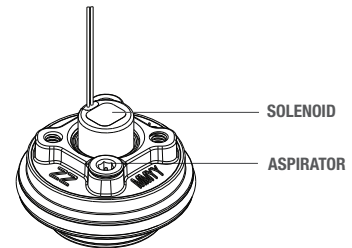

SOLENOID

ASPIRATOR

ITEM NO. 7 - SENSOR ASSEMBLY SELECTION GUIDE		
Code No.	Part No.	Description
LEGACY STYLE CONNECTION - PRIOR TO DECEMBER 2021		
0340130	GBL-123-AC	Closet Sensor Assembly Repair Kit, Legacy connection
0340136	GBL-123-AU	Urinal Sensor Assembly Repair Kit, Legacy connection
PIGTAIL STYLE CONNECTION - AFTER DECEMBER 2021		
33400067	GBL-217-A	Closet Sensor Assembly Repair Kit, Pigtail connection
33400068	GBL-218-A	Urinal Sensor Assembly Repair Kit, Pigtail connection
ITEM NO. 14 - SENSOR SOLENOID REPAIR KIT SELECTION GUIDE		
Code No.	Part No.	Description
LEGACY STYLE CONNECTION - PRIOR TO DECEMBER 2021		
3340025	GBL-1025-A	Solenoid Repair Kit, Legacy connection
PIGTAIL STYLE CONNECTION - AFTER DECEMBER 2021		
33400078	GBL-1096-A	Solenoid Repair Kit, Pigtail connection

TruFlush Hardwired/Battery Flushometer

TROUBLESHOOTING GUIDE

1. Sensor LED Flashes Continuously Only When User Steps Within Range.

- A. Unit is in start-up mode; no problem. This feature is active for the first ten (10) minutes of operation.

2. Red Light Blinks Four (4) Times When User Steps Within Range.

- A. "AA" Batteries depleted; replace batteries, lithium or alkaline. Ensure batteries are installed with proper polarity (+) and (-). **Do not mix** old and new batteries or different types.
- B. (Hardwired) Battery Box not connected; connect Battery Box to Sensor Assembly.

3. Valve Does Not Flush; Sensor Not Picking Up User.

- A. Verify a urinal Sensor is not used on a closet Valve. Model is marked on rear of Sensor.
- B. Range is too short; recalibrate range. Restart the Sensor by holding the Override Button in for 25 seconds, then release the Override Button and step away for one (1) minute; with power connected, this is considered a **Soft Reset**.
- C. For **Hard Reset** of Sensor, remove all power connections (battery and hardwire) for one (1) minute. Reconnect power and step away from front of Sensor for 3½ minutes. Then test Sensor activation by standing in front of Sensor for ten (10) seconds, then step away and wait for flush. Test push button.

4. Valve Does Not Flush; Sensor Picking Up Opposite Wall or Surface, or Only Flushes When Someone Walks By.

Red Light Flashes Continuously for First 10 Minutes Even with No One in Front of the Sensor.

- A. Verify a closet Sensor is not used on a urinal Valve. Model is marked on rear of Sensor.
- B. Range is too long; recalibrate range. Restart the Sensor by holding the Override Button in for 25 seconds, then release the Override Button and step away for one (1) minute; with power connected, this is considered a **Soft Reset**.
- C. If range needs to be manually shortened, reset the Sensor (follow Step 3B) and stand in front of the Sensor at desired range distance for one (1) minute.
- D. For **Hard Reset** of Sensor, remove all power connections (battery and hardwire) for one (1) minute. Reconnect power and step away from front of Sensor for 3½ minutes. Then test Sensor activation by standing in front of Sensor for ten (10) seconds, then step away and wait for flush. Test push button.

5. Valve Does Not Flush Even After Sensor Recalibration.

- A. Ensure water supply to Valve is turned on.
- B. Activation Assembly sleeve is in closed position. Turn counter-clockwise to open water flow. **Note:** there is approximately 1/8-turn (45°) of free spinning as the Activation Assembly engages the Shut Off Sleeve between opening and closing the Valve.
- C. Solenoid wire disconnected from Sensor. Ensure Solenoid wires are intact and Solenoid plug is connected properly.
- D. "AA" Batteries depleted; replace batteries, lithium or alkaline. Ensure batteries are installed with proper polarity (+) and (-). **Do not mix** old and new batteries or different types.
- E. Sensor Assembly malfunctioned. Disconnect power for one (1) minute, reconnect power, and check for start-up operation (flashing red LED). See Step 4D.
- F. Check Solenoid for activation (clicking noise when pressing Sensor Override Button). If no clicks are heard, then contact Technical Support.

6. Valve Does Not Shut Off.

- A. Ensure Solenoid is connected to Sensor.
- B. Supply line water pressure has dropped and is not sufficient to close the Valve. Close Activation Assembly until pressure is restored.
- C. Piston Filter Screen is clogged, Piston is damaged, or large debris stuck behind Piston. Turn off water at Shut Off Sleeve, release pressure, remove Safety Collar and Activation Assembly. Remove Piston and check inside Valve for large debris. **Do not attempt to remove Piston filter screen.** Replace Piston if damaged or cleaning does not correct the problem.

7. Too Much Water To Fixture.

- A. Excessive flow pressure. Readjust Activation Assembly by turning clockwise to decrease flow pressure.
- B. Long Flush. Worn Piston; replace with new proper gpf/Lpf Piston.
- C. Wrong model installed; i.e., 1.6 gpf/6.0 Lpf model installed on 0.5 gpf/1.9 Lpf or 0.25 gpf/1.0 Lpf urinal fixture. Replace with proper model per guide.

8. Not Enough Water To Fixture.

- A. Insufficient flow pressure. Readjust Activation Assembly by turning counter-clockwise to increase flow pressure.
- B. Water supply pressure is inadequate (low). Increase the water supply pressure. Contact the fixture manufacturer for minimum water supply requirements of the fixture.
- C. Wrong model installed; i.e., 0.5 gpf/1.9 Lpf urinal installed on a 1.6 gpf/6.0 Lpf closet fixture. Replace with proper model.
- D. Check lip seal for wear. Replace Piston if lip seal is worn or twisted.

9. Chirping Noise Is Heard At Start Or End Of Flush.

- A. Caused by air purging from the system inside the Valve Assembly. Noise will subside with several flushes or within a day.

10. Valve Leaks Through Aspirator When Activated.

- A. Debris between the umbrella Valve and the Retainer. Blow air on the Aspirator. If this does not correct the problem, remove Retainer with 5 mm Allen Key (not included) and wash it under clean running water. Replace Aspirator if cleaning does not correct the problem.
- B. Loose Retainer. Hand tight Retainer with 5 mm Allen Key (not included). Do not overtighten. Replace Aspirator if this does not correct the problem.

CARE AND CLEANING

DO NOT USE abrasive or chemical cleaners (including chlorine bleach) to clean Flushometers that may dull the luster and attack the chrome or special decorative finishes. Use ONLY mild soap and water, then wipe dry with a clean cloth or towel. If using a cleaner in a spray bottle, DO NOT spray directly onto the Flushometer, instead spray cleaner into a clean cloth and then wipe down the Flushometer.

While cleaning bathroom tile, protect the Flushometer from any splattering of cleaner. Acids and abrasive cleaning fluids will discolor or remove chrome plating.

When assistance is required, please contact Sloan Technical Support at 1.888.SLOAN.14 (1.888.756.2614).

CX Sensor Flushometer

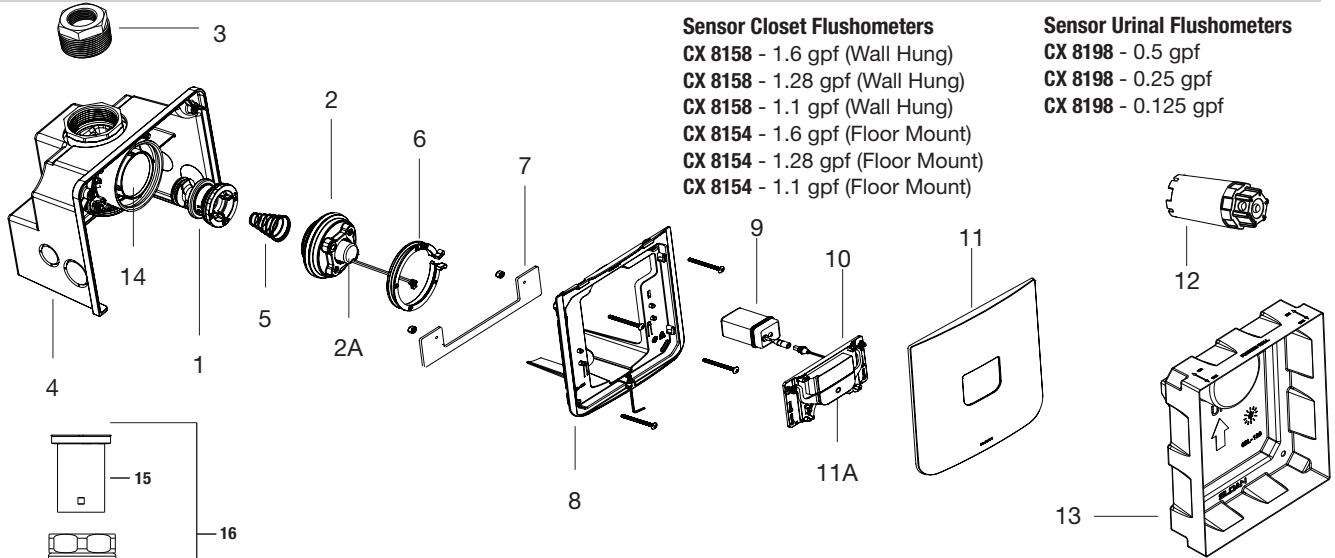

Sensor Closet Flushometers

- CX 8158 - 1.6 gpf (Wall Hung)
- CX 8158 - 1.28 gpf (Wall Hung)
- CX 8158 - 1.1 gpf (Wall Hung)
- CX 8154 - 1.6 gpf (Floor Mount)
- CX 8154 - 1.28 gpf (Floor Mount)
- CX 8154 - 1.1 gpf (Floor Mount)

Sensor Urinal Flushometers

- CX 8198 - 0.5 gpf
- CX 8198 - 0.25 gpf
- CX 8198 - 0.125 gpf

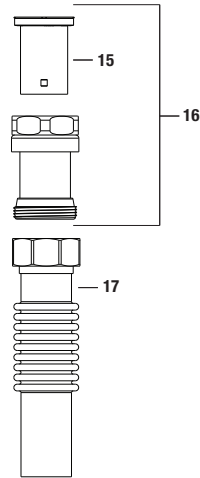

For Model 8158, Wall Hung

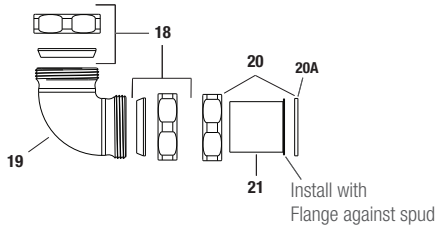

For Model 8198, Urinals

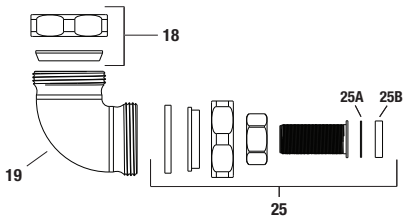

For Model 8154, Floor Mount Exposed Rear Inlet

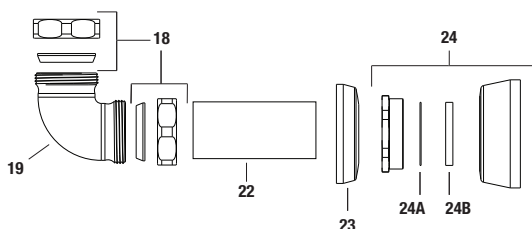

PARTS LIST			
Item No.	Code No.	Part No.	Description
1.	See table on next page		Piston Assembly
2.	See table on next page		Activation Assembly (Includes Item 2A)
2A.	See table on next page		Solenoid Assembly
3.	0340062	GBL-56	Inlet Adapter 1-1/2" NPT x 1" NPT Closet
	0340063	GBL-171	Inlet Adapter 1-1/2" NPT x 3/4" NPT Urinal
4.	—	—	Sensor CX Valve Body and Box Assembly*
5.	—	—	Conical Spring**
6.	3340011	GBL-1011-A	Safety Collar (Collar for Bonnet)
7.	33400011	GBL-214-A	C-Bracket with (2) Lock Nuts and Screws
8.	—	—	Sensor CX Wall Bracket*
9.	9103681PK	ELG-79	Battery Pack
10.	See table on next page		Sensor Assembly Closet
	See table on next page		Sensor Assembly Urinal
11.	See table on next page		Finished Wall Plate
11A.	See table on next page		Override Button Only
12.	3340012	GBL-1012-A	Activation Assembly Tool
13.	33400035	GBL-1062-A	Replacement Mud Guard, Sensor (4 pack)
14.	0340085	GBL-66-A	Shut Off Sleeve (with O-Ring)
* Not sold separately. ** Included with Piston.			
FLUSH CONNECTION PARTS			
Item No.	Code No.	Part No.	Description
15.	3323183	V-651	Vacuum Breaker Repair Kit
16.	0323011	V-500-A	RB Vacuum Breaker Assembly
17.	33060011	F-227-A	Adjustable Tube 6.5" Replacement Kit, 8158, 8198
	33060012	F-228-A	Adjustable Tube 10.5" Replacement Kit, 8154
18.	0306395	F-211-A	CX Poly Washer and Coupling (set of 2)
19.	0306392PK	F-305	CX Elbow for CX Poly Washer
20.	0306091	F-2-A	1-1/2" Coupling Set with S-21 Gasket
20A.	0319079	S-21	1-1/2" Rigid Gasket

CX Sensor Flushometer

FLUSH CONNECTION PARTS CONTINUED			
Item No.	Code No.	Part No.	Description
21.	0306031PK	F-1	1-1/2" x 6" Tube
22.	0396119PK	F-101	CP Tube Outlet 1-1/2" x 10-1/2"
23.	0306237PK	F-7	Tube Flange 1-1/2" x 2-3/4" with Prongs
24.	0306146	F-5-AT	1-1/2" Spud Coupling Assembly CP *
24A.	5306058	F-3	Friction Ring 1-1/2"
24B.	5322001	VBF-5	Slip Joint Gasket 1-1/2"
25.	0306396	—	Urinal Flush Connection Repair Kit
25A.	5306055	F-3	Red Friction Ring 3/4"
25B.	5306113	F-5	Gasket 3/4"

ADDITIONAL PARTS		
Code No.	Part No.	Description
—	F-304	Poly Washer 1-1/2" (Only available in F-211-A, Item 18)
33400019	GBL-1050-A	Sensor CX Finished Wall Plate and Button Assembly, SF [‡]
33400021	GBL-1051-A	Sensor CX Finished Wall Plate and Button Assembly, CP [‡]
33400022	GBL-1052-A	Sensor CX Finished Wall Plate and Button Assembly, BN [‡]
33400023	GBL-1053-A	Sensor CX Finished Wall Plate and Button Assembly, PB [‡]
33400024	GBL-1054-A	Sensor CX Finished Wall Plate and Button Assembly, GR [‡]
33400025	GBL-1055-A	Sensor CX Button Only Replacement Kit, SF
33400026	GBL-1056-A	Sensor CX Button Only Replacement Kit, CP
33400027	GBL-1057-A	Sensor CX Button Only Replacement Kit, BN
33400028	GBL-1058-A	Sensor CX Button Only Replacement Kit, PB
33400029	GBL-1059-A	Sensor CX Button Only Replacement Kit, GR

[‡] Includes mounting screws and wrench.

ITEM NO. 1 - SENSOR PISTON ASSEMBLY SELECTION GUIDE			
Code No.	Part No.	Description	Piston Color*
3340053	GBL-1037-A	1.6 gpf/6.0 Lpf Closet Piston Assembly	Green
33400079	GBL-1098-A	1.28 gpf/4.8 Lpf Closet Piston Assembly	Blue/Black
33400061	GBL-1088-A	1.1 gpf/4.2 Lpf Closet Piston Assembly	Burgundy/Black
3340055	GBL-1039-A	0.5 gpf/1.9 Lpf Urinal Piston Assembly	Red
3340056	GBL-1040-A	0.25 gpf/1.0 Lpf Urinal Piston Assembly	Burgundy
33400003	—	0.125 gpf/0.48 Lpf Urinal Piston Assembly [†]	Red/Pink

NOTE: Item No. 1 includes Item No. 5 (Conical Spring). * Colors may differ. Consult factory to confirm you have the correct Piston Assembly. † 0.125 gpf/0.48 Lpf Valve Components (Piston, Main Seat, and Activation Assembly) are NOT interchangeable with any other flush volume Valves.

ITEM NO. 1 - SENSOR PISTON IDENTIFICATION CHART

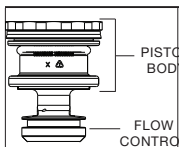
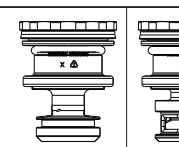
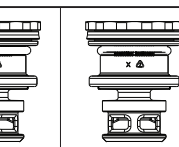
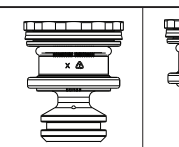
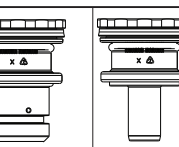
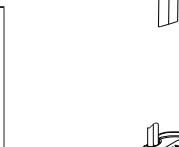
						
	PISTON BODY					
	FLOW CONTROL					
Flush Volume	1.6 gpf Water Closet	1.28 gpf Water Closet	1.1 gpf Water Closet	0.5 gpf Urinal	0.25 gpf Urinal	0.125 gpf Urinal
Piston Body	Green	Light Blue	Burgundy	Red	Burgundy	Red
Flow Control	Green	Black Cage	Black Cage	Red	Burgundy	Pink
Part Number	GBL-1037-A	GBL-1098-A	GBL-1088-A	GBL-1039-A	GBL-1040-A	—
Code Number	3340053	33400079	33400061	3340055	3340056	33400003

ITEM NO. 2 - ACTIVATION ASSEMBLY SELECTION GUIDE			
LEGACY CONNECTION** - PRIOR TO DECEMBER 2021			
Code No.	Part No.	Description	Plug Color*
3340057	GBL-1041-A	1.6 gpf/6.0 Lpf Closet Activation Assembly, Legacy connection	Green
3340058	GBL-1042-A	1.28 gpf/4.8 Lpf Closet Activation Assembly, Legacy connection	Purple
3340059	GBL-1043-A	0.5 gpf/1.9 Lpf Urinal Activation Assembly, Legacy connection	Red
3340060	GBL-1044-A	0.25 gpf/1.0 Lpf Urinal Activation Assembly, Legacy connection	Burgundy
33400006	GBL-1070-A	0.125 gpf/0.48 Lpf Urinal Activation Assembly, Legacy connection	N/A; Nickel plated brass
PIGTAIL CONNECTION** - AFTER DECEMBER 2021			
Code No.	Part No.	Description	Plug Color*
33400051	GBL-1077-A	1.6 gpf/6.0 Lpf Closet Activation Assembly, Pigtail connection	Green
33400052	GBL-1078-A	1.28 gpf/4.8 Lpf Closet Activation Assembly, Pigtail connection	Purple
33400062	GBL-1092-A	1.1 gpf/4.2 Lpf Closet Activation Assembly	Grey
33400053	GBL-1079-A	0.5 gpf/1.9 Lpf Urinal Activation Assembly, Pigtail connection	Red
33400054	GBL-1080-A	0.25 gpf/1.0 Lpf Urinal Activation Assembly, Pigtail connection	Burgundy
33400056	GBL-1081-A	0.125 gpf/0.48 Lpf Urinal Activation Assembly, Pigtail connection	N/A; Nickel plated brass

* Colors may differ. Consult factory to confirm you have the correct assembly.

** Includes Solenoid Repair Kit #2A.

ITEM NO. 2A - SOLENOID ASSEMBLY SELECTION GUIDE		
Code No.	Part No.	Description
33250013	EBV-415-A	Solenoid Assembly with Legacy connection
33400078	GBL-1096-A	Solenoid Assembly with Pigtail connection
ITEM NO. 10 - SENSOR ASSEMBLY SELECTION GUIDE		
Code No.	Part No.	Description
0340271	GBL-209-AC	CX Sensor Assembly for Closet with Legacy connection
0340272	GBL-210-AU	CX Sensor Assembly for Urinal with Legacy connection
33400069	GBL-219-A	CX Sensor Assembly for Closet with Pigtail connection
33400071	GBL-220-A	CX Sensor Assembly for Urinal with Pigtail connection

NOTE: After December 2021, the Activation, Solenoid, and Sensor Assembly connections were changed to a pigtail style connection.

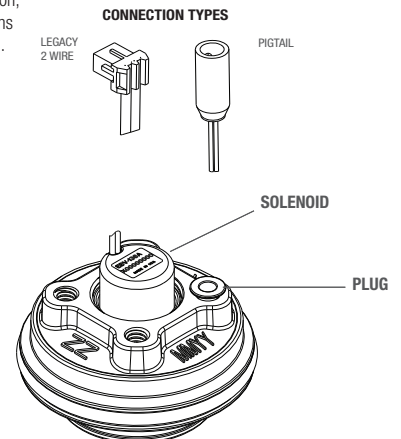

CX Sensor Flushometer

TROUBLESHOOTING GUIDE

1. Sensor LED Flashes Continuously Only When User Steps Within Range.

A. Unit is in start-up mode; no problem. This feature is active for the first ten (10) minutes of operation.

2. Red Light Blinks Four (4) Times When User Steps Within Range.

A. "AA" Batteries depleted; replace batteries, lithium or alkaline. Ensure batteries are installed with proper polarity (+) and (-). **Do not mix** old and new batteries or different types.

B. (Hardwired) Battery Box not connected; connect Battery Box to Sensor Assembly.

3. Valve Does Not Flush; Sensor Not Picking Up User.

A. Verify a urinal Sensor is not used on a closet Valve. Model is marked on rear of Sensor.

B. Range is too short; recalibrate range. Restart the Sensor by holding the Override Button in for 25 seconds, then release the Override Button and step away for one (1) minute; with power connected, this is considered a **Soft Reset**.

C. For **Hard Reset** of Sensor, remove all power connections (battery and hardwire) for one (1) minute. Reconnect power and step away from front of Sensor for 3½ minutes. Then test Sensor activation by standing in front of Sensor for ten (10) seconds, then step away and wait for flush. Test push button.

4. Valve Does Not Flush; Sensor Picking Up Opposite Wall or Surface, or Only Flushes When Someone Walks By.

Red Light Flashes Continuously for First 10 Minutes Even with No One in Front of the Sensor.

A. Verify a closet Sensor is not used on a urinal Valve. Model is marked on rear of Sensor.

B. Range is too long; recalibrate range. Restart the Sensor by holding the Override Button in for 25 seconds, then release the Override Button and step away for one (1) minute; with power connected, this is considered a **Soft Reset**.

C. If range needs to be manually shortened, reset the Sensor (follow Step 3B) and stand in front of the Sensor at desired range distance for one (1) minute.

D. For **Hard Reset** of Sensor, remove all power connections (battery and hardwire) for one (1) minute. Reconnect power and step away from front of Sensor for 3½ minutes. Then test Sensor activation by standing in front of Sensor for ten (10) seconds, then step away and wait for flush. Test push button.

5. Valve Does Not Flush Even After Sensor Recalibration.

A. Ensure water supply to Valve is turned on.

B. Activation Assembly sleeve is in closed position. Turn counter-clockwise to open water flow. **Note:** there is approximately 1/8-turn (45°) of free spinning as the Activation Assembly engages the Shut Off Sleeve between opening and closing the Valve.

C. Solenoid wire disconnected from Sensor. Ensure Solenoid wires are intact and Solenoid plug is connected properly.

D. "AA" Batteries depleted; replace batteries, lithium or alkaline. Ensure batteries are installed with proper polarity (+) and (-). **Do not mix** old and new batteries or different types.

E. Sensor Assembly malfunctioned. Disconnect power for one (1) minute, reconnect power, and check for start-up operation (flashing red LED). See Step 4D.

F. Check Solenoid for activation (clicking noise when pressing Sensor Override Button). If no clicks are heard, then contact Technical Support.

6. Valve Does Not Shut Off.

A. Ensure Solenoid is connected to Sensor.

B. Supply line water pressure has dropped and is not sufficient to close the Valve. Close Activation Assembly until pressure is restored.

C. Piston Bypass is clogged, Piston is damaged, or large debris stuck behind Piston. Turn off water at Shut Off Sleeve, release pressure, remove Safety Collar and Activation Assembly. Remove Piston and check inside Valve for large debris. Replace Piston if damaged or cleaning does not correct the problem.

7. Too Much Water to Fixture.

A. Excessive flow pressure. Readjust Activation Assembly by turning clockwise to decrease flow pressure.

B. Long Flush. Worn Piston; replace with new proper gpf/Lpf Piston.

C. Wrong model installed; i.e., 1.6 gpf model installed on 0.5 gpf/1.9 Lpf or 0.25 gpf/1.0 Lpf urinal fixture. Replace with proper model per guide.

8. Not Enough Water to Fixture.

A. Insufficient flow pressure. Readjust Activation Assembly by turning counter-clockwise to increase flow pressure.

B. Water supply pressure is inadequate (low). Increase the water supply pressure. Contact the fixture manufacturer for minimum water supply requirements of the fixture.

C. Wrong model installed; i.e., 0.5 gpf/1.9 Lpf urinal installed on a 1.6 gpf/6.0 Lpf closet fixture. Replace with proper model.

D. Check lip seal for wear. Replace Piston if lip seal is worn or twisted.

9. Chirping Noise is Heard at the Start or End of Flush.

A. Caused by air purging from the system inside the Valve Assembly. Noise will subside with several flushes or within a day.

CARE AND CLEANING

DO NOT USE abrasive or chemical cleaners (including chlorine bleach) to clean Flushometers that may dull the luster and attack the chrome or special decorative finishes. Use mild soap and water, then wipe dry with a clean soft cloth or towel. If using a cleaner in a spray bottle, **DO NOT spray directly onto the Flushometer**, instead spray cleaner into a clean cloth and then wipe down the Flushometer.

While cleaning surrounding bathroom tile, protect the Flushometer from any splattering of cleaner. Acids and abrasive cleaning fluids will discolor or remove chrome plating.

IMPORTANT NOTE FOR 1.1 GPF FLUSHOMETERS & REPLACEMENT KITS

Sloan 1.1 gpf/4.2 Lpf ultra-high efficiency flushometers meets all applicable standards and requirements. However, with low flush volumes it is imperative that they only be used in conjunction with toilet fixtures and drain line systems designed to operate with adequate flow rates and volumes in order to effectively eliminate waste and move it out of the building. It is the responsibility of the user to ensure both of these conditions are met. Not doing so may void your warranty.

Sloan 1.1 gpf diaphragm and piston kits are designed as a replacement part for Sloan 1.1 gpf/4.2 Lpf flushometers only. They are not intended to be used as a means to reduce water consumption in flushometers with higher flush volumes such as 1.28 gpf/4.8 Lpf or 1.6 gpf/6.0 Lpf or higher. Using this kit in any manner other than with a Sloan 1.1 gpf flushometer may void your warranty.

When assistance is required, please contact Sloan Technical Support at 1.888.SLOAN.14 (1.888.756.2614).

G2 Flushometer

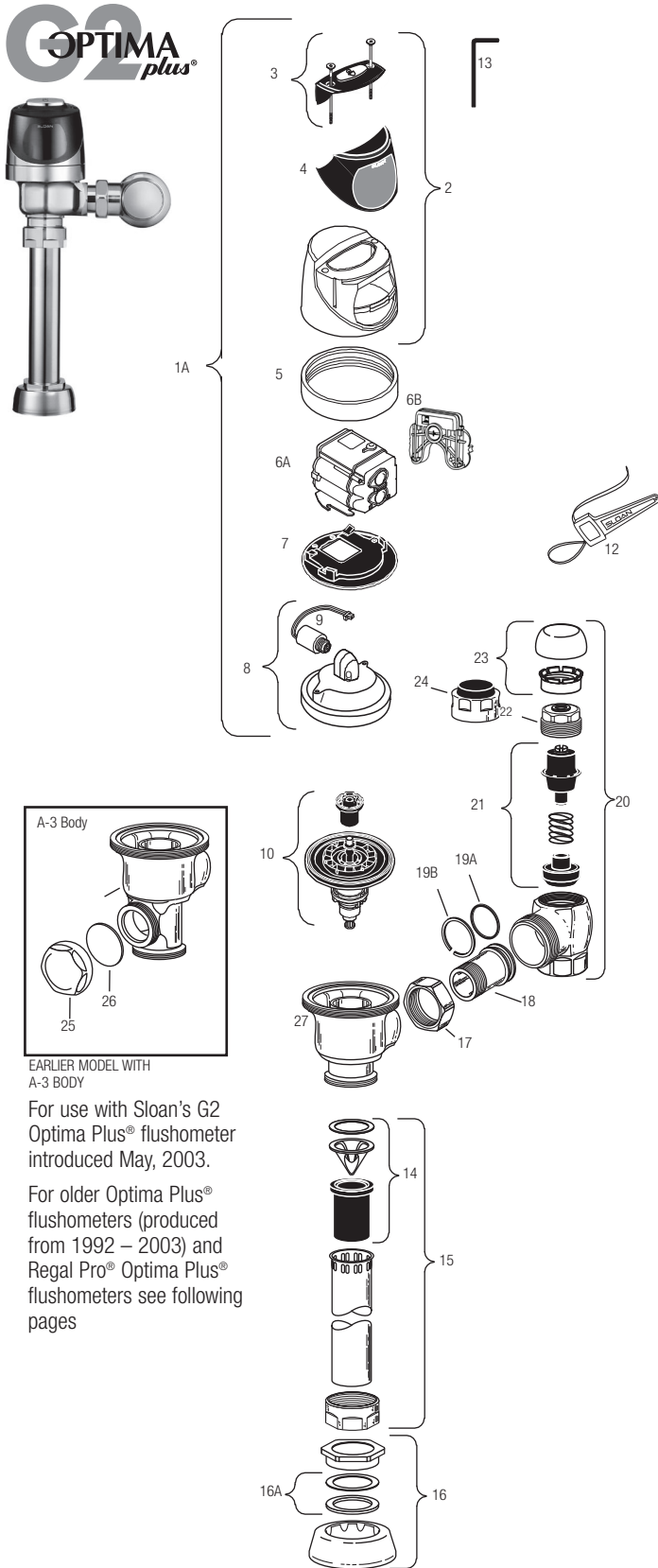

EARLIER MODEL WITH A-3 BODY

For use with Sloan's G2 Optima Plus® flushometer introduced May, 2003.

For older Optima Plus® flushometers (produced from 1992 – 2003) and Regal Pro® Optima Plus® flushometers see following pages

SENSOR MODULE COMPONENT PARTS

Item No.	Code No.	Part No.	Description
1A.	0325160PK	EBV-138-A	G2 Cover/Ring/Sensor Assembly – Water Closet
	0325161PK	EBV-139-A	G2 Cover/Ring/Sensor Assembly – Urinal
	0325166	EBV-149-A	G2 Cover/Ring/Sensor Assembly Water Closet - fits Zurn† valve bodies
	0325167PK	EBV-150-A	G2 Cover/Ring/Sensor Assembly Urinal fits Zurn† bodies
2.	0325168	EBV-142-A	Cover Assembly
3.	0325172	EBV-130-A	Override Button Assembly includes screws & wrench
	0325170	EBV-132-A	Screws (2) and Allen Wrench Only
4.	0325169	EBV-131	Lens Window Cover
5.	0325804	EBV-14	Locking Ring CP
	0325210	EBV-168	Locking Ring CP DISCONTINUED
	3325524	EBV-31-A	Locking Ring – fits Zurn† valve bodies
6A.	3325450	EBV-129-A-C	G2 Electronic Module – Water Closet
	3325451	EBV-129-A-U	G2 Electronic Module – Urinal
	33250047	EBV387A-BT‡	G2 Electronic Module Urinal 0.5 gpf
	33250048	EBV-129A-BT‡	G2 Electronic Module Urinal 1.0 gpf
	33250051	EBV-129AC-BT‡	G2 Electronic Module Water Closet 1.6 gpf
	33250052	EBV-129AC-BT‡	G2 Electronic Module Water Closet 1.28 gpf
6B.	33250012	—	Battery Door Replacement
7.	0325171	EBV-134	Cover Rest Plate
8.	3325456	EBV-145-A	Inside Cover Assembly (includes EBV-136-A)
	3325089	EBV-1010-A	Inside Cover Assembly (includes EBV-145-A & EBV-14)
9.	3325453	EBV-136-A	Solenoid (For G2 Modules only)*
10.	SEE CHART NEXT PAGE		Flex Tube Diaphragm Kit

ACCESSORIES

†1.	0325107	EBV-91	Trimpot Adjustment Screwdriver DISCONTINUED not shown
12.	0305823	EBV-22	Strap Wrench
13.	0325159PK	EBV-137-A	Allen Wrench 7/64"

VALVE COMPONENT PARTS

14.	3323182	V-651-A	Vacuum Breaker Repair Kit
15.	0393046	V-600-AA	3/4" x 10 1/2" CP Vacuum Breaker (10" Outlet Tube)
	0393020	V-600-AA	1-1/4" x 10 1/2" CP Vacuum Breaker (10" Outlet Tube)
	0393021	V-600-AA	1-1/2" x 10 1/2" CP Vacuum Breaker (10" Outlet Tube)
16.	0306125	F-5-AW	3/4" CP Spud Coupling
	0306140	F-5-AU	1-1/4" CP Spud Coupling
	0306146	F-5-AT	1-1/2" CP Spud Coupling

16A.SEE SLIP JOINT GASKETS AND RINGS TABLE ON NEXT PAGE

17.	0308676PK	H-550	CP Stop Coupling
18.	0308801	H-551-A	CP Adjustable Tailpiece 2-1/16" long
19A.	5308696	H-553	O-ring – 24 per package
19B.	5308381	H-552	Locking ring – 12 per package
20.	3308386	H-700-A	1" Screwdriver Bak-Chek® Stop CP – complete
	3308384	H-700-A	3/4" Screwdriver Bak-Chek® Stop CP – complete
21.	3308853	H-541-A	Control Stop Repair Kit †
	3308856	H-543-A	Control Stop Repair Kit † 3/4" H-540/H-600 only
22.	0308612PK	H-622	CP Bonnet †
	0308843	H-577	CP Bonnet † – DISCONTINUED
23.	3308772	H-1010-A	Vandal Resistant Control Stop Cap Assembly †
	3308790	H-1009-A	Vandal Resistant Control Stop Cap Assembly †
24.	3325816	EBV-1019-A	3/4" Decorative Stop Cap
	3308866	H-574	1" Decorative Stop Cap
25.	3325814	EBV-1017-A	Handle Cap — Metal (includes blind nut rubber gasket)
26.	5311042	K-46	Blind Nut Gasket (48 per pack)
27.	0305381PK	EBV-36-A	Squatty Valve Body
28.	3388015	H-1015	Flow Control Kit (HEU Only) (not Shown)

† For use with 1" and 3/4" H-700-A and 1" H-600-A Bak-Chek® screwdriver control stop

‡ For use with H-600-A 3/4" screwdriver Bak-Chek® control stops

* Refer to Page 58 for instructions regarding solenoid replacement.

‡ BlueTooth Enabled.

†The brands and/or products names referenced herein may be subject to trademark rights of their respective owners. Use of the brands and names is for identification purposes only and does not imply affiliation with or endorsement by Sloan.

G2 Flushometer

Sloan introduced its Optima Plus® battery powered sensor flushometer in 1992, revolutionizing the flushing of water closets and urinals. In both new construction and retrofit applications, the use of the Optima Plus has become the standard method for many facilities to improve restroom hygiene and ensure handicap accessibility compliance.

In May, 2003 Sloan introduced the G2 Optima Plus®.

The G2 Optima Plus® builds on the success of the original product and offers many technological advancements to further improve on performance and reliability expected of sensor activated plumbing. In addition to a new aesthetic design, the G2 Optima Plus® features a new state-of-the-art electronic and optical package and a solenoid operator. The G2 Optima Plus replaces the original Optima Plus® product, which was phased out of production in mid-2003.

The Sloan G2 Optima Plus® automatic battery powered flushometer relies on an infrared sensor to detect a user and activate a flushing cycle. No physical contact with the flushometer surface is necessary, assuring sanitary protection. G2 Optima Plus® flushometers are ADA compliant devices.

The flushometer is triggered by means of an active infrared sensor. The Optima Plus® sensor emits a continuous invisible light beam. When a user enters the beam's effective range, the beam is reflected into the Optima Plus scanner window. The user is now detected. After the user moves out of the effective range of the sensor, a signal is sent to the flushometer solenoid and, after appropriate arming and/or flush delays, the flush cycle is initiated.

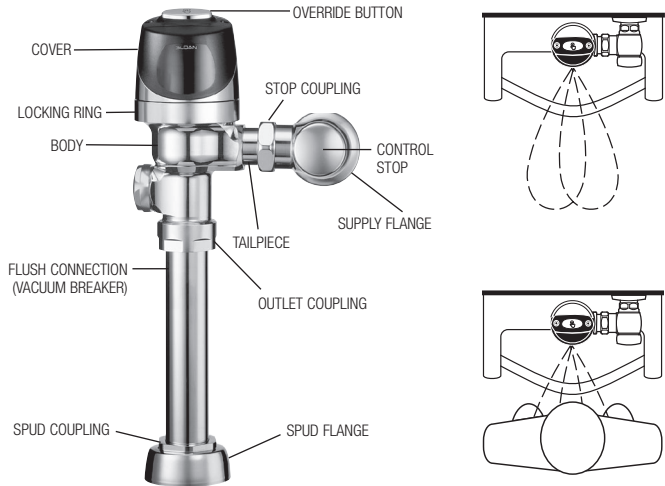

ITEM 10. FLEX TUBE DIAPHRAGM KIT

Code No.	Part No.	Description	Regulator Color *
3325090	EBV-1025-A	Urinal-0.125 gpf/0.25 gpf	GREEN
3325003	EBV-1023-A	Urinal-0.5 gpf/1.9 Lpf†	GREEN
3325000	EBV-1022-A	Urinal-1.0 gpf/3.8 Lpf	GREEN
3325000	EBV-1022-A	Urinal-1.5 gpf/5.7 Lpf †	BLACK
3325001	EBV-1020-A	Urinal-3.5 gpf/13.2 Lpf †	WHITE
3325031	EBV-1024-A	Closet-1.28 gpf/4.8 Lpf	GREEN
3325001	EBV-1020-A	Closet-1.6 gpf/6.0 Lpf †	GREEN
3325014	EBV-1021-A	Closet-2.4 gpf/9.0 Lpf	BLUE
3325001	EBV-1020-A	Closet-3.5 gpf/13.2 Lpf	WHITE
3325001	EBV-1020-A	Closet-4.5 gpf/17.0 Lpf §	WHITE

† EBV-1020-A and EBV-1022-A are supplied with multiple regulators.
 ‡ A 0.5 gpf (1.9 Lpf) urinal kit can be converted to a 1.0 gpf (3.8 Lpf) by cutting and removing the smooth A-164 flow ring from the guide.
 § For a 4.5 gpf (17 Lpf) water closet flush use EBV-1020-A with the white regulator, and cut and remove the A-164 flow ring from the guide.
 * Color of regulator to be used with flex tube diaphragm to obtain the listed flush volume.

EBV-1025-A includes H-1015A Flow Control

O-RING

Code No.	Part No.	Description
5325056	EBV-83	O-ring – 6 per package

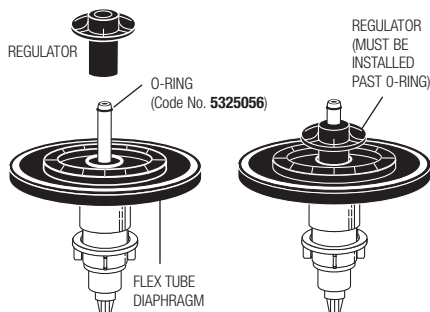

REGULATORS

The flush volume of the flex tube diaphragm kit is controlled by the regulator. Regulators are identified by color. Some flex tube diaphragm kits are supplied with multiple regulators. The installer must make sure the proper regulator is used when installing the flex tube diaphragm kit.

REGULATOR (SOLD 6 PER PACKAGE)

Code No.	Part No.	Description	Regulator Color
5325122	EBV-95	Urinal-0.25 gpf/1.0 Lpf	GREEN
5325122	EBV-95	Urinal-0.5 gpf/1.9 Lpf	GREEN
5325122	EBV-95	Urinal-1.0 gpf/3.8 Lpf	GREEN
5325129	EBV-102-2	Urinal-1.5 gpf/5.7 Lpf	BLACK
5325130	EBV-102-1	Urinal-3.5 gpf/13.2 Lpf	WHITE
5325122	EBV-95	Closet-1.28 gpf/4.8 Lpf	GREEN
5325122	EBV-95	Closet-1.6 gpf/6.0 Lpf	GREEN
5325130	EBV-102-1	Closet-3.5 gpf/13.2 Lpf	WHITE
5325128	EBV-101	Closet-2.4 gpf/9.0 Lpf	BLUE

EBV-1020-A and EBV-1022-A are supplied with multiple flush volume regulators. The installer must use the correct regulator when installing the kit.

ITEM 16A. SLIP JOINT GASKETS AND RINGS

Size	Code No.	Part No.	Description
1-1/2"	5306058	F-3	Red Friction Ring
	5322001	VBF-5	Black Slip Joint Gasket
	5319086	S-30	Flexible Seat
	0319079	S-21	Rigid Seat (rubber over brass)
1-1/2" x 1-1/4"	0396062	F-105	Slip Joint Gasket – Rigid
	5306057	F-3	Red Friction Ring
1-1/4"	5322176	VBF-5	Black Slip Joint Gasket
	0307052/5307052	G-21	Rigid Seat (rubber over brass)
1"	5306056	F-3	Red Friction Ring
	5306115	F-5	Black Slip Joint Gasket
3/4"	5306055	F-3	Red Friction Ring
	5306113	F-5	Black Slip Joint Gasket

G2 Flushometer

SOLENOID REPLACEMENT



Code No.	Part No.	Description
3325453	EBV-136-A	Solenoid operator

For G2 Optima Plus® modules (identified by a blue module).

1. Turn off water and relieve pressure by loosening Tailpiece coupling and re-tighten. Loosen and remove top screws along with the outer cover assembly.



2. Disconnect wire clip from battery door and remove module from inner metal cover assembly.

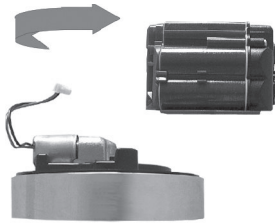
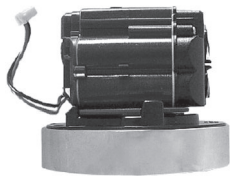

3. Remove Solenoid by turning counter clockwise. Remove any remaining O-rings or parts in orifice.

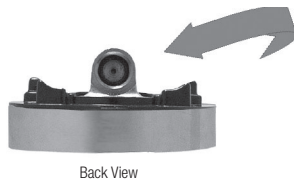
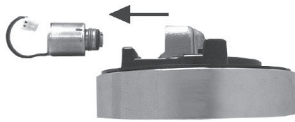

4. Remove black plastic Housing from the threaded end of new Solenoid Operator by unscrewing (counterclockwise). It is normal to find fluid inside this housing.

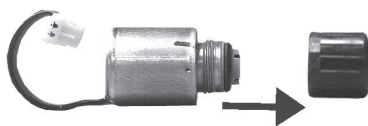

5. Make sure all O-rings (2) are installed on the grey End cap of the new Solenoid Operator. Install Solenoid Operator by threading it (clockwise) into the Housing. Tighten with fingers beyond just snug.

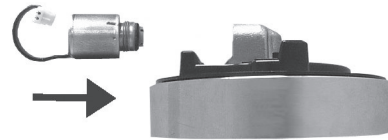

6. Mount module on inner cover assembly. Reconnect the plastic clip on the battery door.

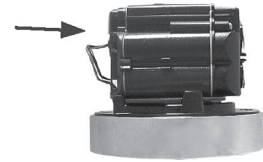
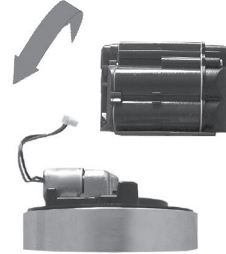

7. Assemble outer cover assembly.



Note: Verify that rubber insert is installed

8. Turn on water at control stop. Installation complete.



G2 Flushometer

BATTERY REPLACEMENT

When G2 Optima Plus® has approximately 4,000 flushes left, the same red light that appears at start-up will flash four (4) times quickly whenever an object is detected. When this occurs, we recommend changing the batteries as follows:

When required, replace batteries with four (4) type AA batteries.

Note: Water does not have to be turned off to replace batteries.

Loosen the two (2) screws on top of unit. Remove the complete cover assembly. Lift the sensor module from its plate. Unplug the electrical connector from battery compartment cover. Loosen the retaining screw on battery compartment cover and remove battery compartment cover. Install four (4) alkaline type AA batteries exactly as illustrated at right.

Install battery compartment cover and secure with retaining screw. Make certain that battery compartment cover is fully compressed against gasket to provide a seal; Do not overtighten. Plug the electrical connector into the battery compartment cover. Reinstall the sensor module onto the plate. Reinstall the complete cover assembly onto the plate. Tighten the two (2) screws on top of the unit.

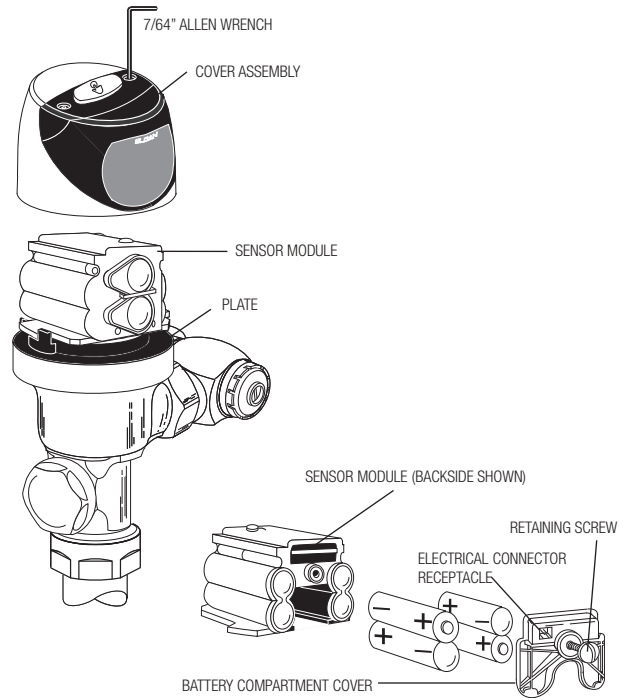

RANGE ADJUSTMENT (ADJUST ONLY IF NECESSARY)

The Optima Plus has a factory set sensing range:

Water Closet Models - 22" to 42" (559 mm to 1067 mm)

Urinal Models - 15" to 30" (381 mm to 762 mm)

The Factory setting should be satisfactory for most installations.

If the range is too short (i.e., not picking up users) or too long (i.e., picking up opposite wall or stall door) the range can be adjusted.

Note: Water does not have to be turned off to adjust range.

Make sure to remove all the non-permanent targets in sensor view area. Push manual override button for 25 seconds. the Red LED in the G2 sensor starts slow blinking. Release the button during the LED blinking. The G2 will enter into distance setting mode. The setting mode will run for one (1) minute.

!!! IMPORTANT !!!
WHEN ADJUSTING RANGE FOR URINAL SENSOR, MAKE SURE TO SETUP A PROPER TARGET IN FRONT OF URINAL SENSOR.

G2 Flushometer

TROUBLESHOOTING AND MAINTAINING THE SLOAN G2 OPTIMA PLUS® FLUSHOMETER

IMPORTANT: This product contains mechanical and/or electrical components that are subject to normal wear. These components should be checked on a regular basis and replaced as needed to maintain the valve's performance.

Never open Control Stop to where the flow from the valve exceeds the flow capability of the fixture. In the event of a valve failure, the fixture must be able to accommodate a continuous flow from the valve.

ATTENTION INSTALLERS: With the exception of the control stop inlet, DO NOT USE pipe sealant or plumbing grease on any valve component or coupling! To protect the chrome or special finish of Sloan flushometers, DO NOT USE toothed tools to install or service these valves. Use our A-50 Super-Wrench™ or other smooth-jawed wrench to secure couplings. Regulations for low consumption fixtures (1.6 gpf/6.0 Lpf closets and 1.0 gpf/3.8 Lpf urinals) prohibit use of higher flush volumes.

1. Sensor flashes continuously only when user steps within range.

- A. Unit in start-up mode; no problem. This feature is active for the first ten (10) minutes of operation.

2. Valve does not flush; sensor not picking up user.

- A. Range too short; increase the range.

3. Valve does not flush; sensor picking up opposite wall or surface, or only flushes when someone walks by. Red light flashes continuously for first ten 10 minutes even with no one in front of the sensor.

- A. Range too long; shorten range.

4. Valve does not flush even after adjustment.

- A. Batteries completely used up; replace batteries.
- B. Problem with electronic sensor module; replace electronic sensor module.

5. Unit flashes 4 quick times when user steps within range.

- A. Batteries low; replace batteries.

6. Valve does not shut off.

- A. By-pass orifice in diaphragm is clogged with dirt or debris, or by-pass is clogged by an invisible gelatinous film due to "over-treated" water. Remove flex tube diaphragm and wash under running water.

Note: Size of orifice in the by-pass is of utmost importance for the proper metering of water by the valve. **DO NOT ENLARGE OR DAMAGE THIS ORIFICE.** Replace flex tube diaphragm if cleaning does not correct the problem.

- B. Dirt or debris fouling stem or flex tube diaphragm. Remove flex tube diaphragm and wash under running water.
- C. O-ring on stem of flex tube diaphragm is damaged or worn. Replace O-ring if necessary.
- D. Problem with solenoid. If cleaning does not correct problem, replace with new solenoid operator.

7. Not enough water to fixture.

- A. Wrong flush volume regulator installed in flex tube diaphragm kit. Install the correct regulator.
- B. Wrong Optima Plus® model installed; i.e., 1.0 gpf urinal installed on 3.5 gpf closet fixture. Replace with proper Optima Plus model.
- C. Enlarged by-pass in diaphragm. Replace flex tube diaphragm.
- D. Control stop not adjusted properly. Readjust control stop.
- E. Inadequate volume or pressure at supply. Increase water pressure or supply (flow) to valve. Consult factory for assistance.

8. Too much water to fixture.

- A. Wrong flush volume regulator installed in flex tube diaphragm kit. Install the correct regulator.
- B. Control stop not adjusted properly. Readjust control stop.
- C. Wrong Optima Plus model installed; i.e., 3 gpf model installed on 1.0 or 1.5 gpf urinal fixture.
- D. Dirt in diaphragm by-pass. Clean under running water or replace flex tube diaphragm.

Note: The EBV-46-A beam deflector is no longer required or available for the G2 Optima Plus.

CARE AND CLEANING INSTRUCTIONS

DO NOT USE abrasive or chemical cleaners to clean the flushometer, they may dull the luster and attack the plastic cover and the chrome finish of the flushometer. Use **ONLY** mild soap and water, then wipe dry with clean cloth or towel.

While cleaning the bathroom tile, the Optima Plus should be protected from any splattering of cleaner. Acids and cleaning fluids can discolor or remove chrome plating.

When assistance is required, please contact Sloan Technical Support at: 1-888-SLOAN-14 (1-888-756-2614).

Optima® Flushometer



OPTIMA

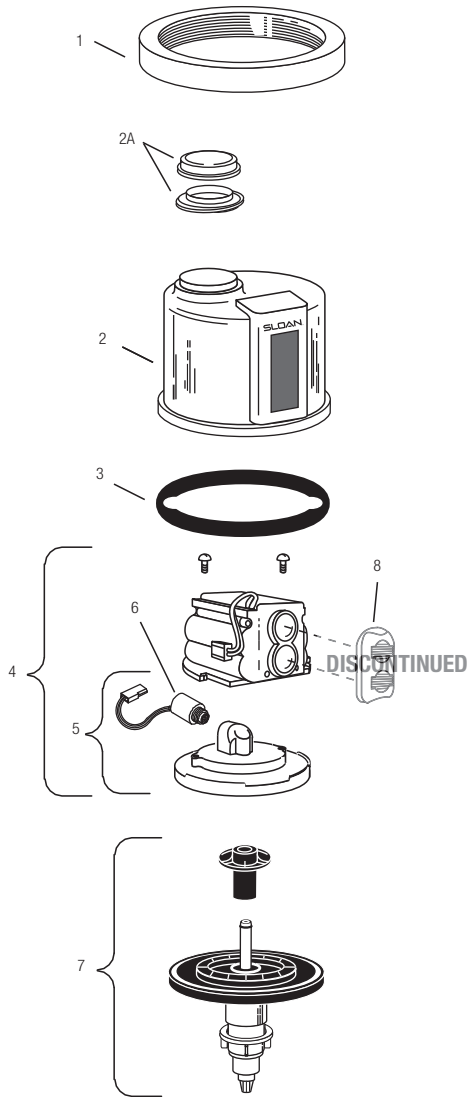

For all Optima Plus® produced from 1992 – 2003 and Regal Pro® Optima Plus® produced after May, 2003.
See the G2 Optima Plus® flushometer section for current parts.

SENSOR MODULE COMPONENT PARTS

Item No.	Code No.	Part No.	Description
1.	0325804PK	EBV-14	Locking Ring
	3325524	EBV-31-A	Locking Ring fits Zurn† valve bodies
2.	3325013	EBV-60-A	Metal Cover Assembly with Override Button (Water Closet)
	3325016	EBV-1033-A	Metal Cover Assembly w/Override Button fits Zurn† valve bodies
2A.	3325055	EBV-1042-A	Replacement Override Button Kit for plastic covers (Old Style)
3.	5325011	EBV-67	Cover Gasket — 12 per package
4.	SEE CHART PAGE 63 — ELECTRONIC MODULE		
5.	0325814	EBV-21-A	Inside Cover Assembly (Includes EBV-144-A Solenoid)
6.	3325462	EBV-144-A	Solenoid Operator †
7.	SEE CHART PAGE 86 — Flex Tube Diaphragm Kit		
8.	3325537	EBV-46-A	Beam Deflector † — DISCONTINUED

† The new EBV-144-A solenoid replaces the solenoid used with the old style black EBV-26-A modules only. For blue EBV-146-A-U or EBV-146-A-C G2 modules, use the EBV-136-A solenoid operator. Refer to module assembly chart for instructions regarding solenoid replacement.
 † Beam deflectors are for use on black, old style modules. They are not required (and will not work) on Blue G2 modules.

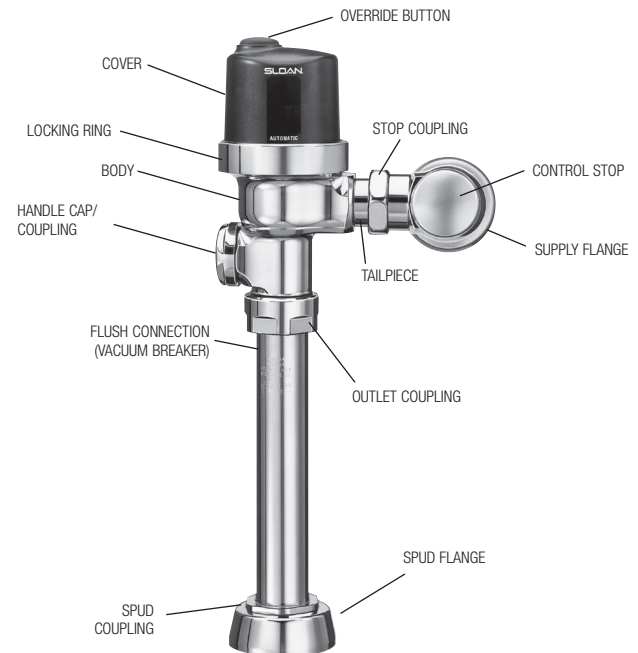

†The brands and/or products names referenced herein may be subject to trademark rights of their respective owners. Use of the brands and names is for identification purposes only and does not imply affiliation with or endorsement by Sloan.

Optima® Flushometer

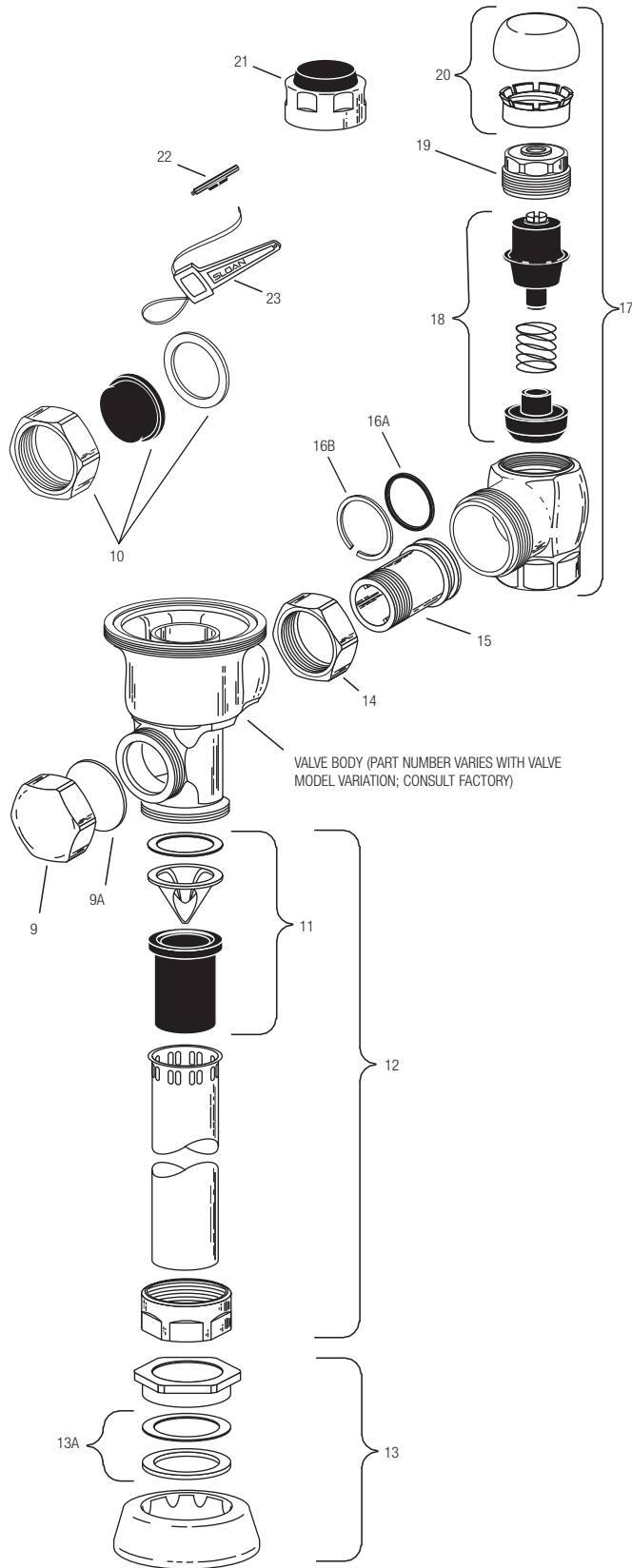

OTHER VALVE COMPONENT PARTS

Item No.	Code No.	Part No.	Description
9.	3325814	EBV-1017-A	Handle Cap — Metal
9A.	5311042	K-46	Blind Nut Gasket
10.	3325815	EBV-1018-A	Handle Cap — Metal Coupling/Plastic Hole Cap — DISCONTINUED
11.	3323182	V-651-A	Vacuum Breaker Repair Kit
12.	3393004	V-600-AA	3/4" (19 mm) x 10 1/2" (254 mm) CP Vacuum Breaker (10" Outlet Tube)
	3393006	V-600-AA	1-1/4" (32 mm) x 10 1/2" (254 mm) CP Vacuum Breaker (10" Outlet Tube)
	3393007	V-600-AA	1-1/2" (38 mm) x 10 1/2" (254 mm) CP Vacuum Breaker (10" Outlet Tube)
13.	0306125	F-5-AW	3/4" (19 mm) CP Spud Coupling
	0306140	F-5-AU	1-1/4" (32 mm) CP Spud Coupling
	0306146	F-5-AT	1-1/2" (38 mm) CP Spud Coupling
13A.	SEE SLIP JOINT GASKETS AND RINGS TABLE BELOW		
14.	0308676PK	H-550	CP Stop Coupling
15.	0308801	H-551-A	CP Adjustable Tailpiece 2-1/16" (52 mm) long
16A.	5308696	H-553	O-ring — 24 per package
16B.	5308381	H-552	Locking ring — 12 per package
17.	3308386	H-700-A	1" (25 mm) Screwdriver Bak-Chek® Stop CP — complete
	3308384	H-700-A	3/4" (19 mm) Screwdriver Bak-Chek® Stop CP — complete
18.	3308853	H-541-A	Control Stop Repair Kit † 3/4" H-600/H-540 only
	3308856	H-543-A	Control Stop Repair Kit †
19.	0308612PK	H-622	CP Bonnet †
	0308843	H-577	CP Bonnet 3/4" H-600/H-540 only — DISCONTINUED †
20.	3308772	H-1010-A	Vandal Resistant Control Stop Cap Assembly†
	3308790	H-1009-A	Vandal Resistant Control Stop Cap Assembly†
21.	3325816	EBV-1019-A	3/4" (19 mm) Decorative Stop Cap
	3308866	H-574	1" (25 mm) Decorative Stop Cap

ACCESSORIES

22.	0325107	EBV-91	Trimpot Adjustment Screwdriver
23.	0305823	EBV-22	Disposable Strap Wrench

† For use w/H-700-A 1" & 3/4" and H-600-A 1" screwdriver Bak-Chek® control stops, also marked with Quiet Stop II

‡ For use w/H-600-A 3/4" urinal screwdriver Bak-Chek® control stops, also marked with Quiet Stop II.

ITEM 13A. SLIP JOINT GASKETS AND RINGS

Size	Code No.	Part No.	Description
1-1/2"	5306058	F-3	Red Friction Ring
	5322001	VBF-5	Black Slip Joint Gasket
	5319086	S-30	Flexible Seat
	0319079	S-21	Rigid Seat (rubber over brass)
1-1/2" x 1-1/4"	0396062	F-105	Slip Joint Gasket — Rigid
1-1/4"	5306057	F-3	Red Friction Ring
	5322176	VBF-5	Black Slip Joint Gasket
	0307052/5307052	G-21	Rigid Seat (rubber over brass)
1"	5306056	F-3	Red Friction Ring
	5306115	F-5	Black Slip Joint Gasket
3/4"	5306055	F-3	Red Friction Ring
	5306113	F-5	Black Slip Joint Gasket

Optima® Flushometer

ELECTRONIC MODULE ASSEMBLY CHART

The electronic and optical improvements of the G2 Optima Plus® have been incorporated into the electronic modules for use with older Optima Plus products.

Optima Plus® modules can be identified by color.

Old style modules are black and have a wire that runs along the side of the unit.

G2 modules are blue and have a wire only on the back of the unit.

There are now only two electronic module assembly variations for use with older Optima Plus valves:

EBV-146-A-U Urinal
EBV-146-A-C Water closet

This chart cross references the part numbers and code numbers of our new electronic modules over from our old module numbers.

The modules include the solenoid, inner cover and electronic module.

These modules are for use with older Optima Plus and Regal Pro® Optima Plus® valves only.

Code No.	Use Part No.	Description	To Replace Old Part No.
0325177	EBV-146-A-U	Electronic — 0.5 gpf/1.9 Lpf Urinal Module	EBV-26-A-U-0.5
0325177	EBV-146-A-U	Electronic — 1.0 gpf/3.8 Lpf Urinal Module	EBV-26-A-U-1.0
0325177	EBV-146-A-U	Electronic — 1.5 gpf/5.7 Lpf Urinal Module	EBV-26-A-U-1.5
0325177	EBV-146-A-U	Electronic — 3.5 gpf/13.2 Lpf Urinal Module	EBV-26-A-U-3.5
0325176	EBV-146-A-C	Electronic — 1.6 gpf/6.0 Lpf Closet Module	EBV-26-A-C-1.6
0325176	EBV-146-A-C	Electronic — 2.4 gpf/9.0 Lpf Closet Module	EBV-26-A-C-2.4
0325176	EBV-146-A-C	Electronic — 3.5 gpf/13.2 Lpf Closet Module	EBV-26-A-C-3.5
0325176	EBV-146-A-C	Electronic — 4.5 gpf/17.0 Lpf Closet Module	EBV-26-A-C-4.5

Note: EBV-26-A modules are no longer available. Use the EBV-146-A-U or EBV-146-A-C module shown.

ELECTRONIC SENSOR MODULE

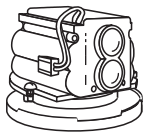

BATTERY REPLACEMENT

When Optima Plus has approximately 4,000 flushes left, the same red light that appears at start-up will flash four (4) times quickly whenever an object is detected. When this occurs, we recommend changing the batteries. On Optima Plus, shut off water and relieve pressure.

Separate locking ring, cover and diaphragm from electronic sensor module.

Loosen retaining screw on battery compartment door and remove battery compartment door. Install four (4) AA batteries exactly as illustrated. Install battery compartment door and secure with retaining screw. Make certain that battery compartment door is fully compressed against gasket to provide a seal; do not overtighten.

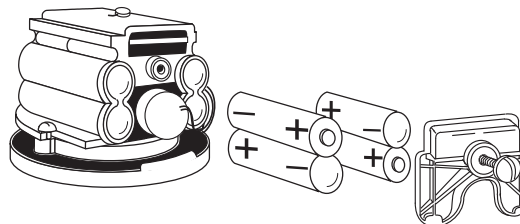

FLEX TUBE DIAPHRAGM ASSEMBLY

In early 2003 Sloan introduced the flex tube diaphragm kit into the Optima Plus. This design completely replaced the old Optima Plus diaphragm kit that featured the metal shaft with the quad Ring. This change further improved the reliability of the Optima Plus as it replaced a wearable dynamic seal (the Quad Ring) with a non-moving static O-ring seal.

The flex tube diaphragm kit also features Sloan's exclusive dual-filter diaphragm. The dual-filter diaphragm helps to protect the valve from water-borne sediment that can cause the valve to stick open and run on. The dual-filter diaphragm is also made from Sloan's Permex® synthetic rubber material for resistance against chloramines and other water treatment chemicals.

The flex tube diaphragm can be used to replace all generations of Sloan Optima Plus® diaphragm kits. The same flex tube diaphragm kits are used in the G2 Optima Plus® valve.



Optima® Flushometer

FLEX TUBE DIAPHRAGM KITS

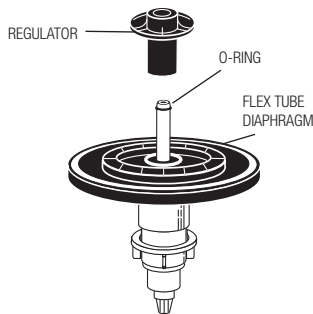

Code No.	Description
5325056	O-ring – 6 per package

Code No.	Use Part No.	Description	Color*	To Replace Old Part No.
3325090	EBV-1025-A	URINAL	GREEN	— 0.125 gpf/0.25 Lpf
3325003	EBV-1023-A	URINAL	GREEN	EBV-32-A-U-0.5 (0.5 gpf/1.9 Lpf [†])
3325000	EBV-1022-A	URINAL	GREEN	EBV-32-A-U-1.0 (1.0 gpf/3.8 Lpf [†])
3325000	EBV-1022-A	URINAL	BLACK	EBV-32-A-U-1.5 (1.5 gpf/5.7 Lpf [†])
3325001	EBV-1020-A	URINAL	WHITE	EBV-20-A-U-3.5 (3.5 gpf/13.2 Lpf [†])
3325031	EBV-1024-A	CLOSET	GREEN	— 1.28 gpf/4.8 Lpf
3325001	EBV-1020-A	CLOSET	GREEN	EBV-10-A-C-1.6 (1.6 gpf/6.0 Lpf [†])
3325014	EBV-1021-A	CLOSET	BLUE	EBV-10-A-C-2.4 (2.4 gpf/9.0 Lpf)
3325001	EBV-1020-A	CLOSET	WHITE	EBV-10-A-C-3.5 (3.5 gpf/13.2 Lpf [†])
3325001	EBV-1020-A	CLOSET	WHITE	EBV-10-A-C-4.5 (4.5 gpf/17.0 Lpf [‡])

† The EBV-1020-A and EBV-1022-A kits are supplied with multiple regulators.
 ‡ A 0.5 gpf (1.9 Lpf) urinal kit can be converted to a 1.0 gpf (3.8 Lpf) by cutting and removing the smooth A-164 flow ring from the guide.
 § For a 4.5 gpf (17.0 Lpf) water closet flush, use the EBV-1020-A kit with the white regulator, and cut and remove the A-164 flow ring from the guide.
 * Color of regulator to be used with flex tube diaphragm to obtain the listed flush volume.

REGULATORS

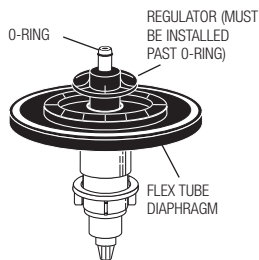

The flush volume of the flex tube diaphragm kit is controlled by the regulator. Regulators are identified by color. Some flex tube diaphragm kits are supplied with multiple regulators. The installer must make sure the proper regulator is used when installing the flex tube diaphragm kit.

REGULATOR (Sold 6 per package)

Code No.	Part No.	Description	Regulator Color
5325122	EBV-95	Urinal-0.5 gpf/1.9 Lpf	GREEN
5325122	EBV-95	Urinal-1.0 gpf/3.8 Lpf	GREEN
5325129	EBV-102-2	Urinal-1.5 gpf/5.7 Lpf	BLACK
5325130	EBV-102-1	Urinal-3.5 gpf/13.2 Lpf	WHITE
5325122	EBV-95	Closet-1.28 gpf/4.8 Lpf	GREEN
5325122	EBV-95	Closet-1.6 gpf/6.0 Lpf	GREEN
5325130	EBV-102-1	Closet-3.5 gpf/13.2 Lpf	WHITE
5325128	EBV-101	Closet-2.4 gpf/9.0 Lpf	BLUE

The EBV-1020-A and EBV-1022-A kits are supplied with multiple flush volume regulators. The installer must use the correct regulator when installing the kit.

OLD STYLE DIAPHRAGM INSIDE PARTS



The 5325813 Quad Ring is still available.

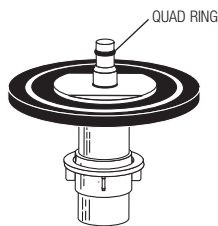

Code No.	Part No.	Description
5325813	EBV-18	Quad Ring – 12 per package

OLD STYLE KITS ABOVE ARE OBSOLETE. SEE CHART FOR REPLACEMENT.

Optima® Flushometer

(All Optima products manufactured prior to May, 2003)

SOLENOID REPLACEMENT



Code No. Part No. Description

3325462 EBV-144-A Solenoid operator

For use with black Optima Plus® EBV-26-A modules only (produced 1992-2003).
For G2 Optima Plus® modules (identified by a blue module) use the EBV-136-A solenoid.

1. Remove battery cover and batteries from existing sensor module.

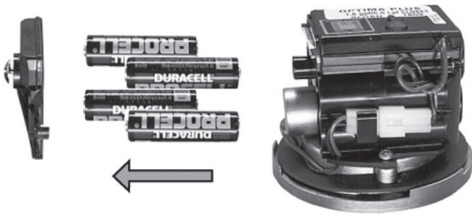

2. Disconnect the white plastic connector that connects the black and red wires on the side of the module.

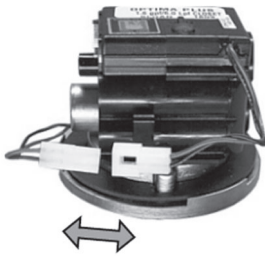

3. Unscrew (counterclockwise) the existing solenoid valve from the base plate.

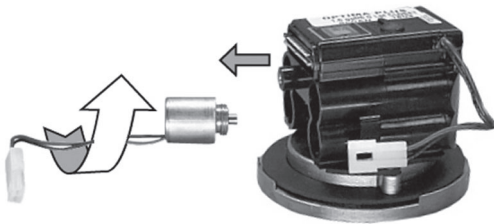

4. Remove white plastic seat and O-rings that are located inside the housing.

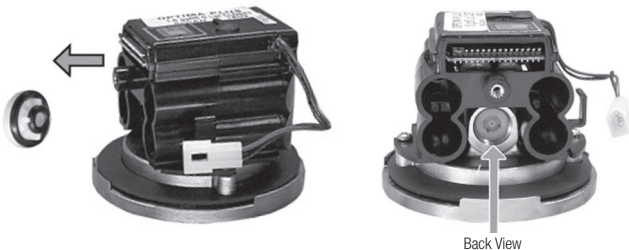

5. Remove clear plastic housing from the threaded end of new operator by unscrewing (counterclockwise). It is normal to find water inside this housing.

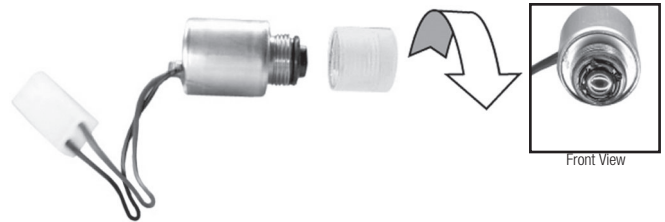

6. Make sure O-ring is installed on the gray housing of the new operator. Install solenoid operator by threading it (clockwise) into the housing. Tighten with fingers beyond just snug.

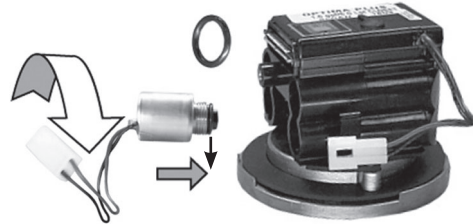

7. Reinstall batteries in the correct position and reattach battery door.

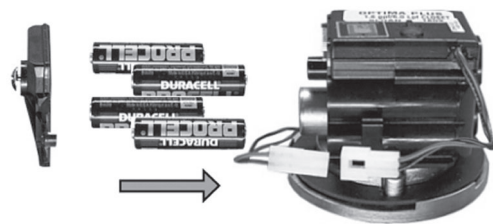

8. Reconnect the white plastic connectors on the side of the module. Slide the white connector into the clip to secure. Tuck wiring in close to module. If valve runs, tighten solenoid further.

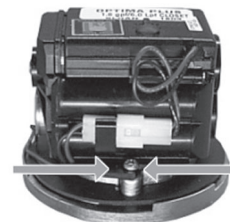

Optima® Flushometer

TROUBLESHOOTING GUIDE

IMPORTANT: The OPTIMA PLUS® flushometer is engineered for quiet operation. Excessive water flow creates noise, while too little water flow may not satisfy the needs of the fixture. Proper adjustment is made when plumbing fixture is cleansed after each flush without splashing water out from the lip AND a quiet flushing cycle is achieved.

Never open Control Stop to where the flow from the valve exceeds the flow capability of the fixture. In the event of a valve failure, the fixture must be able to accommodate a continuous flow from the valve.

ATTENTION INSTALLERS: With the exception of the control stop inlet, DO NOT USE pipe sealant or plumbing grease on any valve component or coupling! To protect the chrome or special finish of Sloan flushometers, DO NOT USE toothed tools to install or service these valves. Use our A-50 Super-Wrench™ or other smooth-jawed wrench to secure couplings. Regulations for low consumption fixtures (1.6 gpf/6.0 Lpf closets and 1.0 gpf/3.8 Lpf urinals) prohibit use of higher flush volumes.

1. Sensor flashes continuously only when user steps within range.

- A. Unit in start-up mode; no problem. This feature is active for the first ten (10) minutes of operation.

2. Valve does not flush; sensor not picking up user.

- A. Range too short; increase the range.
 B. Optima Plus installed on a high rough-in fixture (beam is shooting over the user's head). Install the EBV-46-A beam deflector (black modules only).

3. Valve does not flush; sensor picking up opposite wall or surface, or only flushes when someone walks by. Red light flashes continuously for first ten 10 minutes even with no one in front of the sensor.

- A. Range too long; shorten range.

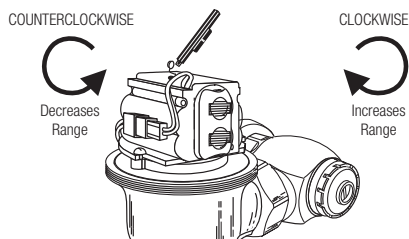

- B. Sensor is picking up mirror or highly reflective wall or surface in front of fixture. Install Optima Plus® slightly "off-center" (2 to 5 degrees) to eliminate direct reflection off of mirror or opposite wall or surface.

4. Valve does not flush even after adjustment.

- A. Range adjustment potentiometer set at full "max" or full "min" setting. Readjust potentiometer away from full "max" or "min" setting.
 B. Batteries completely used up; replace batteries.
 C. Problem with electronic sensor module; replace electronic sensor module.

5. Unit flashes 4 quick times when user steps within range.

- A. Batteries low; replace batteries.

6. Valve does not shut off.

- A. By-pass orifice in diaphragm is clogged with dirt or debris, or by-pass is clogged by an invisible gelatinous film due to "over-treated" water. Remove diaphragm and wash under running water. Replace with new diaphragm if cleaning does not correct the problem.
 B. Dirt or debris fouling stem or flex tube diaphragm. Remove flex tube diaphragm and wash under running water.
 C. Solenoid problem. If cleaning does not correct the problem, replace with new solenoid operator.

7. Not enough water to fixture.

- A. Wrong Optima Plus flex tube diaphragm installed; i.e., 1.0 gpf urinal installed on 3.5 gpf closet fixture. Replace with proper diaphragm assembly.
 B. Enlarged by-pass in diaphragm. Replace with flex tube diaphragm kit.
 C. Control stop not adjusted properly. Readjust control stop.
 D. Inadequate volume or pressure at supply. Increase water pressure or supply (flow) to valve. Consult factory for assistance.

8. Too much water to fixture.

- A. Control stop not adjusted properly. Readjust control stop.
 B. Wrong Optima Plus flex tube diaphragm installed; i.e., 3.0 gpf model installed on 1.0 or 1.5 gpf urinal fixture. Replace with proper Optima Plus diaphragm assembly.
 C. Dirt in diaphragm by-pass. Clean under running water or replace with new flex tube diaphragm.

9. Men's room closet bowls unflushed.

- A. Closet being used as urinal. Angle sensor slightly off fixture centerline to detect standing person in front of fixture.

BATTERIES

When required, replace batteries with four (4) alkaline type AA batteries.

CARE AND CLEANING OF CHROME AND SPECIAL FINISHES

DO NOT USE abrasive or chemical cleaners to clean flushometers as they may dull the luster and attack the chrome or special decorative finishes. Use **ONLY** mild soap and water, then wipe dry with clean cloth or towel.

While cleaning the bathroom tile, the flushometer should be protected from any splattering of cleaner. Acids and cleaning fluids can discolor or remove chrome plating.

When assistance is required, please contact Sloan Technical Support at: 1-888-SLOAN-14 (1-888-756-2614).

Optima® Flushometer

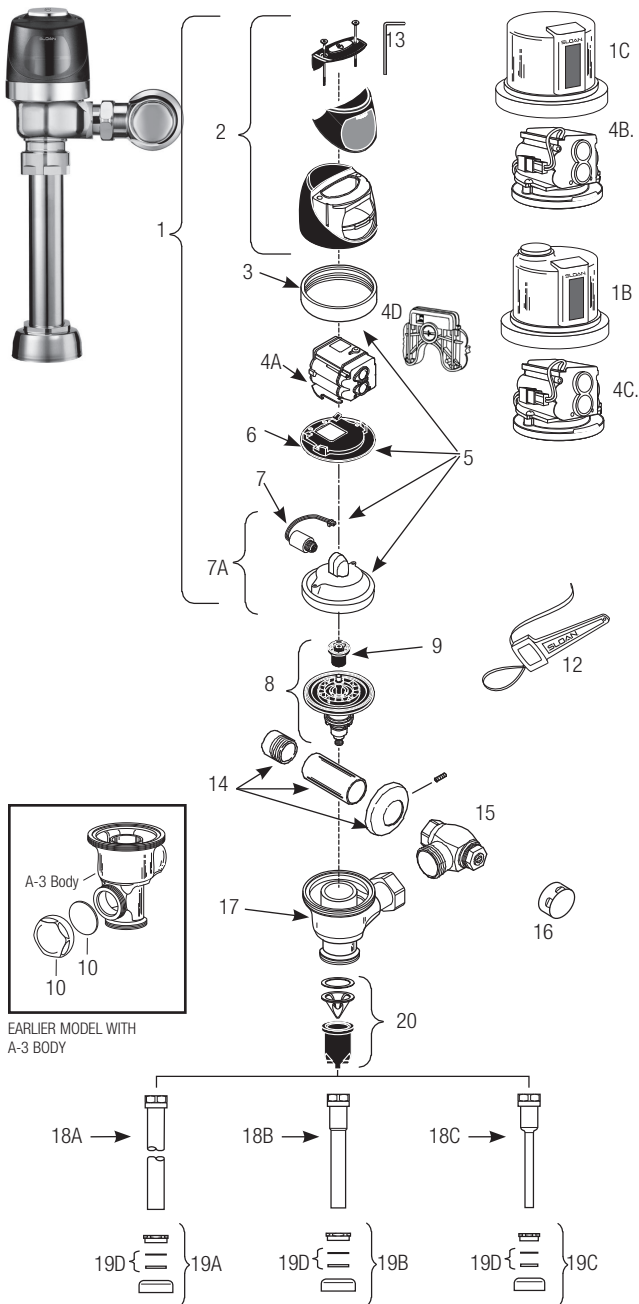

EARLIER MODEL WITH A-3 BODY

PARTS LIST

Item No.	Code No.	Part No.	Description
1.	0325298	EBV-189-A	Cover/Ring/Sensor Assembly - Water Closet
	0325299	EBV-190-A	Cover/Ring/Sensor Assembly - Urinal
	0325239	EBV-198-A	Cover/Ring/Sensor Assembly - Water Closet fits Zurn† valve bodies
	0325240	EBV-199-A	Cover/Ring/Sensor Assembly - Urinal fits Zurn† valve bodies
1B.	3325013	EBV-60-A	Kit Metal Cover w/Override – Water Closet
1C.	3325012	EBV-55A	Kit Metal Cover Less Override- Urinal
2.	0325241	EBV-192-A	Cover Assembly
3.	0325804PK	EBV-14	Locking Ring
	3325524	EBV-31	Locking Ring - fits Zurn† valve bodies
4A.	3325450	EBV-129-A-C	Electronic Module - Water Closet
	3325451	EBV-129-A-U	Electronic Module - Urinal
4B.	0325176	EBV-146A-C	G2 Sensor Assembly-Closet
4C.	0325177	EBV-146A-U	G2 Sensor Assembly-Urinal
4D	33250012	—	Battery Door Cover
5.	3325089	EBV-1010-A	Metal Inner Cover Repair Kit Includes Items Nos. 3, 5, 6 and 7
6.	0325171	EBV-134	Cover Rest Plate
7.	3325453	EBV-136-A	Solenoid
7A.	3325456	EBV-145-A	Inside Cover Assembly (includes solenoid EBV-136-A) Does not replace Plastic Inner Cover. Use Item No. 5
8.	SEE CHART NEXT PAGE		Flex Tube Diaphragm Assembly
9.	SEE CHART NEXT PAGE		Flush Volume Regulator
10.	3325814	EBV-1017	Handle Cap Kit
11.	0325107	EBV-91	Trimpot Adjustment Screwdriver DISCONTINUED
12.	0305823	EBV-22	Strap Wrench
13.	0325159PK	EBV-137	7/64" Hex Wrench
14.	3308785	H-634-AA	1" (25 mm) Sweat Solder Kit
	3308788	H-636-AA	3/4" (19 mm) Sweat Solder Kit
15.	3308386	H-700-A	1" (25 mm) Bak-Chek® Control Stop
	3308384	H-700-A	3/4" (19 mm) Bak-Chek® Control Stop
16.	3308840	H-573-A	Stop Cap
17.	0305381PK	EBV-36-A	Valve Body *
18A.	5323007	V-500-AA	1-1/2" (38 mm) x 10 1/2" (254 mm) Vacuum Breaker (Model 8110/8111) (6 pack)(10" Outlet Tube)
	0323014	V-500-AA	1-1/2" (38 mm) x 13 1/2" (343 mm) Vacuum Breaker (Model 8113)
	0323019	V-500-AA	1-1/2" (38 mm) x 23" (584 mm) Vacuum Breaker (Model 8115)
	0323021	V-500-AA	1-1/2" (38 mm) x 26" (660 mm) Vacuum Breaker (Model 8116)
18B.	5323006	V-500-AA	1-1/4" (32 mm) x 10 1/2" (254 mm) Vacuum Breaker (Model 8180) (10" Outlet Tube)
18C.	5323005	V-500-AA	3/4" (19 mm) x 10 1/2" (254 mm) Vacuum Breaker (Model 8186) (10" Outlet Tube)
19A.	0306145	F-56-A	1-1/2" Spud Coupling Assembly (Models 8110, 8115 & 8116)
19B.	0306142	F-55-A	1-1/4" Spud Coupling Assembly (Model 8180)
19C.	0306102	F-54-A	3/4" Spud Coupling Assembly (Model 8186)
19D.	SEE SLIP JOINT GASKETS AND RINGS TABLE ON NEXT PAGE		
20.	3323192	V-551-A	Vacuum Breaker Repair Kit

* Part number varies with valve model variation; consult factory.

†The brands and/or products names referenced herein may be subject to trademark rights of their respective owners. Use of the brands and names is for identification purposes only and does not imply affiliation with or endorsement by Sloan.

Optima® Flushometer

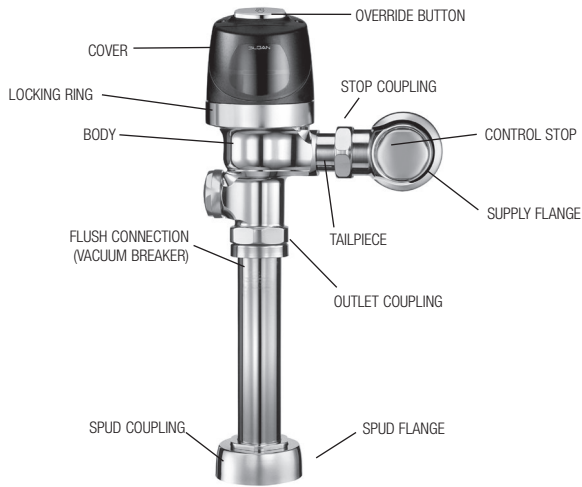

OPERATION

A continuous, invisible light beam is emitted from the Optima Plus® Sensor.

As the user enters the beam's effective range, 22 to 42 inches (559 mm to 1067 mm) for closet installations and 15 to 30 inches (381 mm to 762 mm) for urinal installations, the beam is reflected into the Scanner Window to activate the Output Circuit. Once activated, the Output Circuit continues in a "hold" mode for as long as the user remains within the effective range of the sensor.

When the user steps away, the loss of reflected light initiates an electrical "one-time" signal that activates the flushing cycle to flush the fixture. The Circuit automatically resets and is ready for the next user.

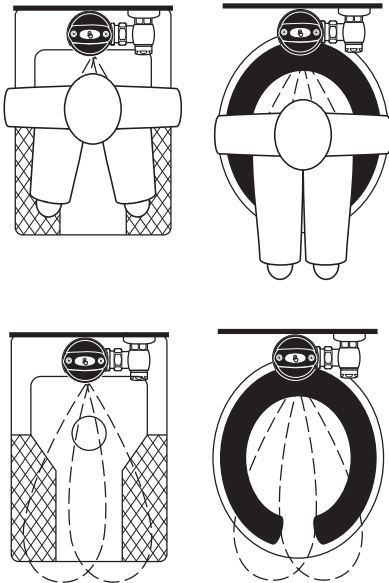

ITEM 8. FLEX TUBE DIAPHRAGM KIT

Code No.	Part No.	Description	Regulator Color *
3325090	EBV-1025-A	Urinal-0.125 gpf/0.25 Lpf	GREEN
3325150	EBV-1050-A	Urinal-0.5 gpf/1.9 Lpf	GREEN
3325151	EBV-1051-A	Urinal-1.0 gpf/3.8 Lpf †	GREEN
3325031	EBV-1024-A	Closet-1.28 gpf/4.8 Lpf	GREEN
3325153	EBV-1053-A	Closet-1.6 gpf/6.0 Lpf †	GREEN
3325152	EBV-1052-A	Closet-2.4 gpf/9.0 Lpf	BLUE

† The EBV-1051-A and EBV-1053-A Kits are supplied with multiple Regulators.

* Color of regulator to be used with flex tube diaphragm to obtain the listed flush volume.

A 1.0 gpf (3.8 Lpf) Urinal kit can be converted to a 1.5 gpf (5.7 Lpf) Urinal by replacing the Green Regulator with the supplied Black Regulator.

A 1.6 gpf (6.0 Lpf) Closet kit can be converted to a 3.5 gpf (13.2 Lpf) Closet by replacing the Green Regulator with the supplied White Regulator.

ITEM 9. REGULATORS

The flush volume of the flex tube diaphragm kit is controlled by the regulator. Regulators are identified by color. Some flex tube diaphragm kits are supplied with multiple regulators. The installer must make sure the proper regulator is used when installing the flex tube diaphragm kit.

REGULATOR (SOLD 6 PER PACKAGE)

Code No.	Part No.	Description	Regulator Color
5325122	EBV-95	Urinal-0.5 gpf/1.9 Lpf	GREEN
5325122	EBV-95	Urinal-1.0 gpf/3.8 Lpf	GREEN
5325122	EBV-95	Closet-1.6 gpf/6.0 Lpf	GREEN
5325128	EBV-101	Closet-2.4 gpf/9.0 Lpf	BLUE

FLEX TUBE DIAPHRAGM ASSEMBLY

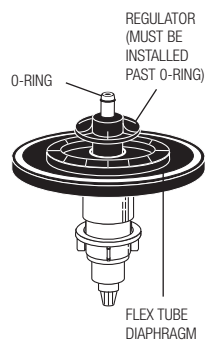

Optima Plus Valve Models Feature Sloan's Exclusive Flex Tube Diaphragm™ for the ultimate in valve performance, reliability and Chloramine resistance.

ITEM 19D. SLIP JOINT GASKETS AND RINGS

Size	Code No.	Part No.	Description
1-1/2"	5306058	F-3	Red Friction Ring
	5322001	VBF-5	Black Slip Joint Gasket
	5319086	S-30	Flexible Seat
	0319079	S-21	Rigid Seat (rubber over brass)
1-1/2" x 1-1/4"	0396062	F-105	Slip Joint Gasket – Rigid
1-1/4"	5306057	F-3	Red Friction Ring
	5322176	VBF-5	Black Slip Joint Gasket
	0307052/5307052	G-21	Rigid Seat (rubber over brass)
1"	5306056	F-3	Red Friction Ring
	5306115	F-5	Black Slip Joint Gasket
3/4"	5306055	F-3	Red Friction Ring
	5306113	F-5	Black Slip Joint Gasket

Optima® Flushometer

BATTERY REPLACEMENT

When required, replace batteries with four (4) AA-Size Batteries.

Note: Water does not have to be turned off to replace batteries.

Loosen the two (2) Screws on top of unit. Remove the complete Cover Assembly. Lift the Sensor Module from its Plate. Unplug the Electrical Connector from Battery Compartment Cover. Loosen the Retaining Screw on Battery Compartment Cover and remove Battery Compartment Cover. Install four (4) Alkaline AA-Size Batteries **exactly** as illustrated.

Install Battery Compartment Cover and secure with Retaining Screw. Make certain that Battery Compartment Cover is fully compressed against Gasket to provide a seal; **Do Not** overtighten. Plug the Electrical Connector into the Battery Compartment Cover. Reinstall the Sensor Module onto the Plate. Tighten the two (2) Screws on top of the unit.

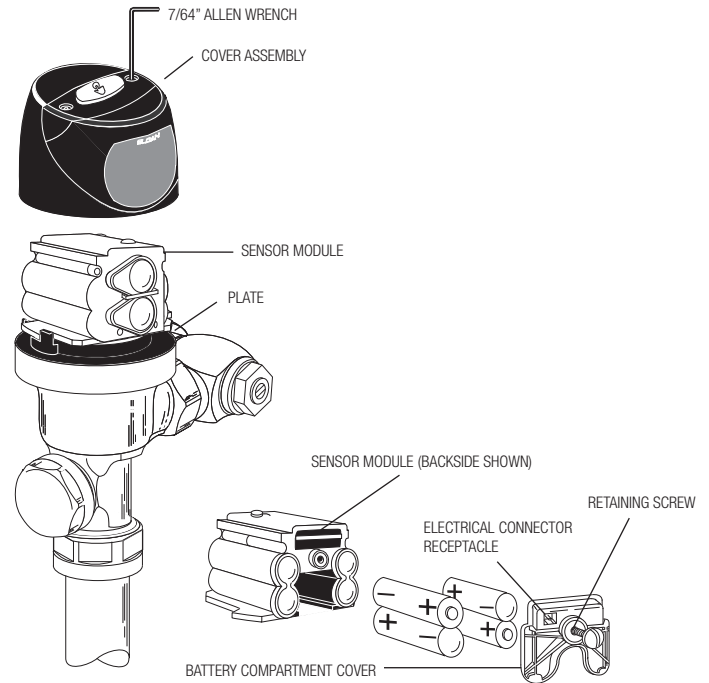

RANGE ADJUSTMENT (ADJUST ONLY IF NECESSARY)

The Optima Plus has a factory set sensing range:

Water Closet Models - 22" to 42" (559 mm to 1067 mm)

Urinal Models - 15" to 30" (381 mm to 762 mm)

The Factory setting should be satisfactory for most installations.

If the range is too short (i.e., not picking up users) or too long (i.e., picking up opposite wall or stall door) the range can be adjusted.

Note: Water does not have to be turned off to adjust range.

Make sure to remove all the non-permanent targets in sensor view area. Push manual override button for 25 seconds. the Red LED in the G2 sensor starts slow blinking. Release the button during the LED blinking. The G2 will enter into distance setting mode. The setting mode will run for one (1) minute.

!!! IMPORTANT !!!
WHEN ADJUSTING RANGE FOR URINAL SENSOR, MAKE SURE TO SET-UP A PROPER TARGET IN FRONT OF URINAL SENSOR.

Optima® Flushometer

TROUBLESHOOTING AND MAINTAINING THE SLOAN OPTIMA PLUS® FLUSHOMETER

IMPORTANT: This product contains mechanical and/or electrical components that are subject to normal wear. These components should be checked on a regular basis and replaced as needed to maintain the valve's performance.

Never open Control Stop to where the flow from the valve exceeds the flow capability of the fixture. In the event of a valve failure, the fixture must be able to accommodate a continuous flow from the valve.

ATTENTION INSTALLERS: With the exception of the control stop inlet, DO NOT USE pipe sealant or plumbing grease on any valve component or coupling! To protect the chrome or special finish of Sloan flushometers, DO NOT USE toothed tools to install or service these valves. Use our A-50 Super-Wrench™ or other smooth-jawed wrench to secure couplings. Regulations for low consumption fixtures (1.6 gpf/6.0 Lpf closets and 1.0 gpf/3.8 Lpf urinals) prohibit use of higher flush volumes.

1. Sensor flashes continuously only when user steps within range.

- A. Unit in Start-Up mode; no problem. This feature is active for the first ten (10) minutes of operation.

2. Valve does not flush; sensor not picking up user.

- A. Range too short; increase the range.

3. Valve does not flush; sensor picking up opposite wall or surface, or only flushes when someone walks by. Red light flashes continuously for first 10 minutes even with no one in front of the sensor.

- A. Range too long; shorten range.

4. Valve does not flush even after adjustment.

- A. Range Adjustment Potentiometer set at full "max" or full "min" setting. Readjust Potentiometer away from full "max" or "min" setting.
- B. Batteries completely used up; replace batteries.
- C. Problem with Electronic Sensor Module; replace Electronic Sensor Module.

5. Unit flashes four (4) quick times when user steps within range.

- A. Batteries low; replace batteries.

6. Valve does not shut off.

- A. Bypass Orifice in Diaphragm is clogged with dirt or debris, or Bypass is clogged by an invisible gelatinous film due to "over-treated" water. Remove Flex Tube Diaphragm and wash under running water.

Note: Size of orifice in the by-pass is of utmost importance for the proper metering of water by the valve. **DO NOT ENLARGE OR DAMAGE THIS ORIFICE.** Replace flex tube diaphragm if cleaning does not correct the problem.

- B. Dirt or debris fouling Stem or Flex Tube Diaphragm. Remove Flex Tube Diaphragm and wash under running water.
- C. O-ring on Stem of Flex Tube Diaphragm is damaged or worn. Replace O-ring if necessary.
- D. Problem with Electronic Sensor Module; replace Sensor Module.

7. Not enough water to fixture.

- A. Wrong Flush Volume Regulator installed in Flex Tube Diaphragm Kit. Install the correct Regulator.
- B. Wrong Optima Plus® Diaphragm kit installed; i.e., 1 gpf. urinal installed on 3.5 gal. closet fixture. Replace with proper Optima Plus diaphragm kit.
- C. Enlarged Bypass in Diaphragm. Replace Flex Tube Diaphragm.
- D. Control Stop not adjusted properly. Readjust Control Stop.
- E. Inadequate volume or pressure at supply. Increase water pressure or supply (flow) to valve. Consult factory for assistance.

8. Too much water to fixture.

- A. Wrong Flush Volume Regulator installed in Flex Tube Diaphragm Kit. Install the correct Regulator.
- B. Control Stop not adjusted properly. Readjust Control Stop.
- C. Wrong Optima Plus Diaphragm kit installed; i.e., 3.5 gpf. closet installed on 0.5 gal. urinal fixture. Replace with proper Optima Plus Diaphragm kit.
- D. Dirt in Diaphragm Bypass. Clean under running water or replace Flex Tube Diaphragm.

CARE AND CLEANING OF CHROME AND SPECIAL FINISHES

DO NOT USE abrasive or chemical cleaners to clean flushometers as they may dull the luster and attack the chrome or special decorative finishes. Use **ONLY** soap and water, then wipe dry with clean cloth or towel.

While cleaning the bathroom tile, the flushometer should be protected from any splattering of cleaner. Acids and cleaning fluids can discolor or remove chrome plating.

When assistance is required, please contact Sloan Technical Support at: 1-888-SLOAN-14 (1-888-756-2614).

Optima® Side Mount Flushometers Dual Flush & Single Flush

EBV-550/Battery Powered
Dual-flush Side Mount

EBV-500/Battery Powered
Single-flush Side Mount



Battery-powered, sensor-activated, retrofit unit for exposed, dual-flush and single-flush closet and single-flush urinal.

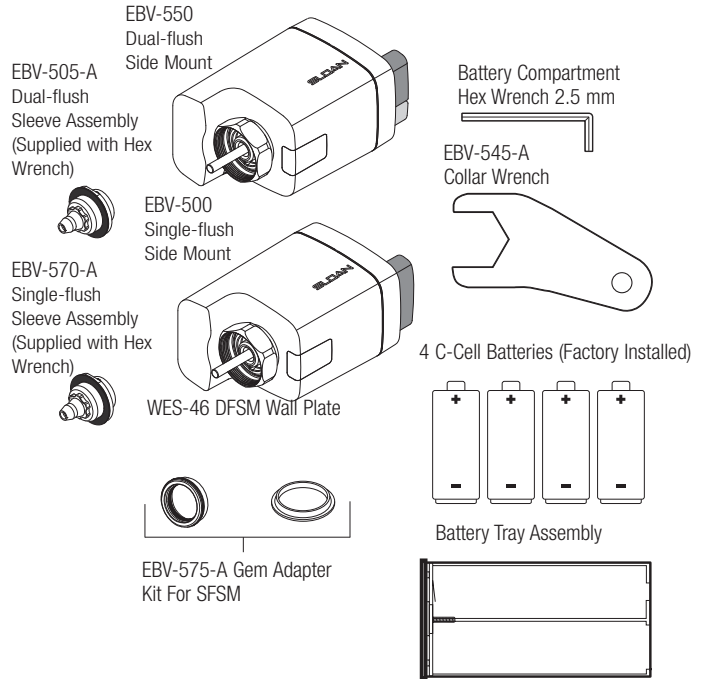

Optima® Side Mount Flushometers Dual Flush & Single Flush

BATTERY REPLACEMENT

Using the supplied battery compartment hex wrench, remove battery compartment from Side Mount unit.

Remove batteries from compartment tray.

Install 4 new C-cell batteries into compartment tray (note the position of batteries in tray), and reinstall compartment tray into the Side Mount unit.

The Side Mount unit comes preset from the factory. If special circumstances require adjustment of the activation distance, please contact Sloan.

The Side Mount unit calibrates upon power up, GREEN and RED LEDs flash once. The unit will actuate a flush followed by 5 flashes of GREEN LED. The unit will then perform calibration, a 20 second sequence, where the GREEN LED flashes quickly. Finally the unit will start normal operation.

Manual flush button on Side Mount unit allows manual activation, when desired.

MODE CHANGE (SINGLE-FLUSH UNITS ONLY)

Units are preset at factory in water closet mode.

To change unit from water closet to urinal mode, complete the following:

Press and hold the True Mechanical Override (TMO) button for 20-30 seconds.

The unit will exhibit an LED flash pattern as follows:

- For approximately the first 10 seconds there will be no LED flashing
- For approximately 10-20 seconds, both the RED and GREEN LEDs will produce short simultaneous flashes
- For approximately 20-30 seconds, the GREEN LED will flash

Release the TMO button during the 20-30 seconds when both the RED and GREEN LEDs produce SHORT simultaneous flashes and remove non-permanent items from view of the sensor. The Side Mount unit will now be in urinal mode* and begin calibration.

To change back to closet mode, press and hold the TMO button for 30-40 seconds. Release when RED and GREEN LEDs produce short simultaneous flashes. The Side Mount unit will now be in close mode and begin calibration.

* Urinal mode provides a shorter sensor range and 1-2 second flush delay.

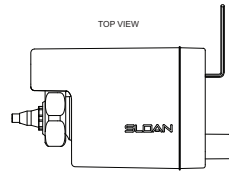

TROUBLESHOOTING GUIDE

1. RED LED continuously flashes when target is present.

The battery is low. Refer to battery replacement instructions.

2. RED LED flashes 4 times after a target has been present for 8 seconds. RED LED flashes once when a target is NOT present.

The battery is low. Refer to battery replacement instructions.

3. RED LED flashes continuously after calibration.

The unit has failed to calibrate. The optics window is obscured. Remove power, clean window and remove any objects (barrels, toolboxes, etc.) within close proximity of unit. Repeat power-up sequence (See BATTERY REPLACEMENT for power-up sequence). If unit fails, consult Sloan Technical Support.

CARE AND CLEANING OF CHROME AND SPECIAL FINISHES

DO NOT USE abrasive or chemical cleaners (including chlorine bleach) to clean side mount unit or flushometer that may dull the luster and attack the finish. Use **ONLY** mild soap and water, then wipe dry with clean cloth or towel.

While cleaning the bathroom tile, protect the side mount unit from any splattering of cleaner. Acids and cleaning fluids can discolor or remove chrome plating.

DO NOT USE abrasive or chemical cleaners (including chlorine bleach) to clean sensor window that may distort or ruin the sensor.

When assistance is required, please contact

Sloan Technical Support at: 1-888-SLOAN-14 (1-888-756-2614).

SMOOTH® Side-mount Flushometer Single-flush

Battery powered, sensor activated retrofit unit for exposed closet and urinal flushometers.



1

PARTS LIST

Item			
No.	Code No.	Part No.	Description
1.	3325201	EBV-200-A	Side Mount Operator for Water Closets (Toilets) and Urinals

SMOOTH® Side-mount Flushometer Single-flush

ADJUSTMENT PROCEDURES

Note: To make the adjustments indicated below, power to unit(s) must be turned off for ten (10) seconds. Mode selection is available within one (1) hour after every power up condition (reinstalling batteries).

Mode A

The SMOOTH unit may be reset to normal range by fully pressing and holding in the Override Handle until the Red LED light in the Sensor Window illuminates. Then immediately release the Override Handle.

Mode B

The SMOOTH unit may be set to reduced range for closet applications by pressing and holding in the Override Handle until the Red LED light in the Sensor Window flashes a slow long blinking light. Then immediately release the Override Handle.

Mode C

The SMOOTH unit may be set to reduced range by pressing and holding in the Override Handle until the Red LED light in the Sensor Window displays a rapid on and off blinking light. Then immediately release the Override Handle.

BATTERIES

When required, replace batteries with four (4) type C batteries.

1. Release Mounting Clamp by turning the Mounting Screw counterclockwise with a 1/8" hex wrench.
2. Swing the Mounting Clamp into the open position.
3. Slide the unit from the flushometer body.
4. Open Battery Compartment Door and remove old batteries from unit. Replace batteries with 4 (four) new C-size batteries. Close Battery Compartment Door. Reinstall unit.

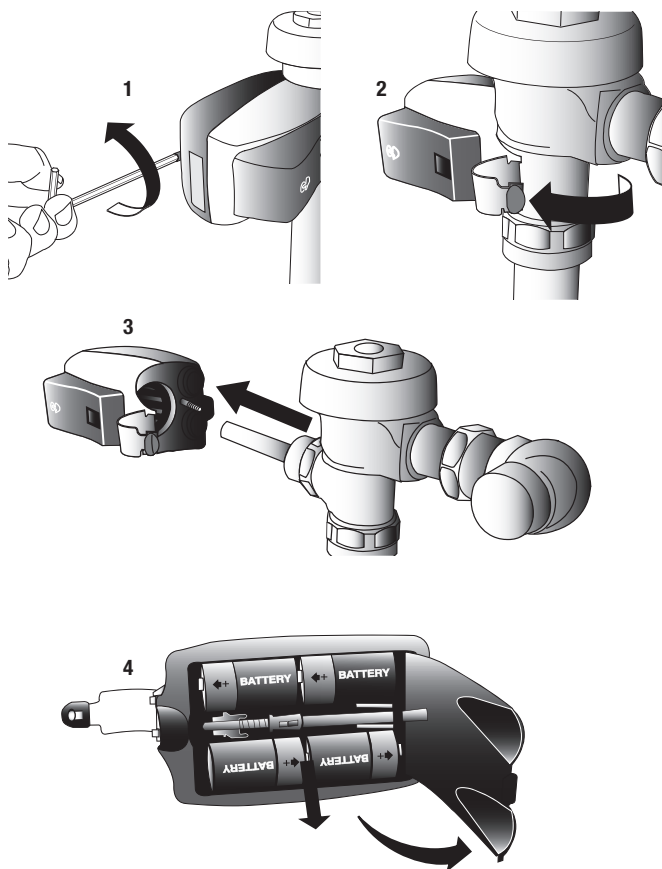

TROUBLESHOOTING GUIDE

1. Red LED light in the sensor window flashes twice as fast as normal.

- A. When a user enters the sensor's effective range and the Red LED light in the sensor window flashes twice as fast as normal, the batteries need replacement. Refer to the Battery Replacement Instructions.

CARE AND CLEANING OF CHROME AND SPECIAL FINISHES

DO NOT USE abrasive or chemical cleaners to clean flushometers as they may dull the luster and attack the chrome or special decorative finishes. Use **ONLY** mild soap and water, then wipe dry with clean cloth or towel.

While cleaning the bathroom tile, the flushometer should be protected from any splattering of cleaner. Acids and cleaning fluids can discolor or remove chrome plating.

When assistance is required, please contact Sloan Technical Support at: 1-888-SLOAN-14 (1-888-756-2614).

SMO Side Mount Flushometer Single-flush

Battery powered, sensor activated retrofit unit for exposed closet and urinal flushometers.



PARTS LIST

Item No.	Code No.	Part No.	Description
1.	0325105	EBV-89-A	Side Mount Operator for Water Closets (Toilets) and Urinals
2.	0301139	A-31	Gasket
3.	0325148	EBV-118	Lens
4.	0325153	EBV-123	Button repair kit
5.	0325150	EBV-120	Wrench
6.	0325157	EBV-127	Metal Cover Closet w/OR
7.	—	EBV-119	Allen Wrench 3mm security hex
8.	0325192	EBV-157-A	Handle Adapter Kit (Includes Green "L" Gasket) for GEM-2®
9.	5302297	B-39	Handle Seal (pack of 12)
10.	5325428	EBV-584	Gasket (Green) GEM SMO (pack of 5)

Note: Battery door screw is not an available part. Use M4-0.7 x 12 mm screw as suitable replacement.

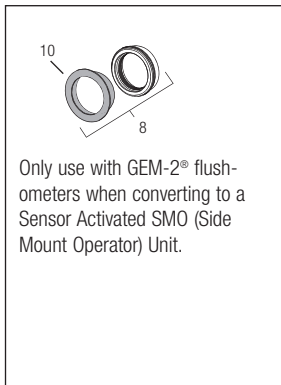
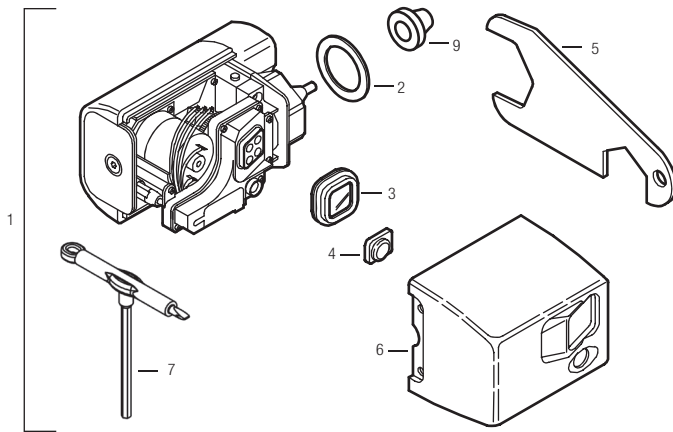

SMO Side Mount Flushometer Single-flush

TO CHANGE ACTIVATION DISTANCE FOR THE OBJECT LOCK SENSOR

1. Remove battery compartment tray as shown at right.
2. Remove cover as shown at right.
3. Remove sensor adjuster tool as shown at right. Replace battery compartment in Side Mount Operator to activate unit.
4. Press sensor range reset button as shown below (the green L.E.D. will flash continuously when it has an object in view for the seven minute reset period).
5. Stand at desired activation distance.
6. Use sensor adjuster tool (see below) and turn Distance Adjustment Screw all the way down and then turn slowly up until green L.E.D. begins to flash.
7. Ensure Object Lock Sensor is not detecting stall door or wall by closing door, stepping out of sensor path and making sure green L.E.D. is not flashing. If sensor locks onto door or wall, unit will not flush properly. Shorten activation distance.
8. Remove battery compartment, replace sensor adjuster tool and cover. Replace battery compartment tray to reactivate Side Mount Operator unit.
9. After 7 minute start-up sequence, the green L.E.D. will flash only 3 times when a user is in view (after a 5 second delay).

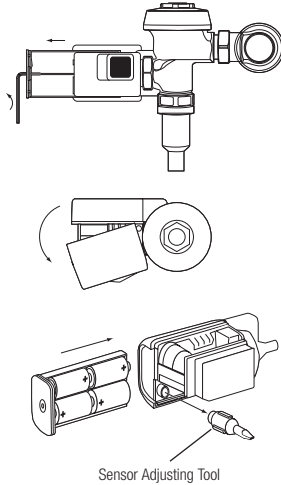

TROUBLESHOOTING GUIDE

- 1. Green L.E.D. (light) flashes 3 times when there are no users**
 - A. Front of Object Lock Sensor is covered or Object Lock Sensor is set too far out, registering the opposite wall or door as a user. Remove item covering sensor or adjust Object Lock Sensor activation distance. (See section – Adjusting Your Side Mount Operator)
- 2. Green L.E.D. (light) flashes continuously when Object Lock Sensor is activated by a user**
 - A. Side Mount Operator unit is in 7 minute start up mode (when first activated) or Sensor Range Reset Button has been depressed. Green L.E.D. (light) will flash only 3 times acknowledging a user is in view after the 7 minute start up mode
- 3. Orange L.E.D. (light) flashes**
 - A. Batteries need replacing. Replace batteries.
- 4. Not enough water to fixture or too much water to fixture**
 - A. Diaphragm damaged or valve control stop improperly adjusted. Replace diaphragm and/or adjust valve control stop
- 5. Valve will not operate**
 - A. Object Lock Sensor range set too close to Side Mount Operator, batteries are dead, or water supply is turned off. Adjust Object Lock Sensor – Replace batteries – Turn water on.
- 6. Valve does not shut off**
 - A. Dirt or debris preventing diaphragm from functioning properly. Remove dirt or debris, consult valve manufacturer's directions.
- 7. Valve does not flush even after Object Lock Sensor has been adjusted**
 - A. Dead batteries. Replace batteries.

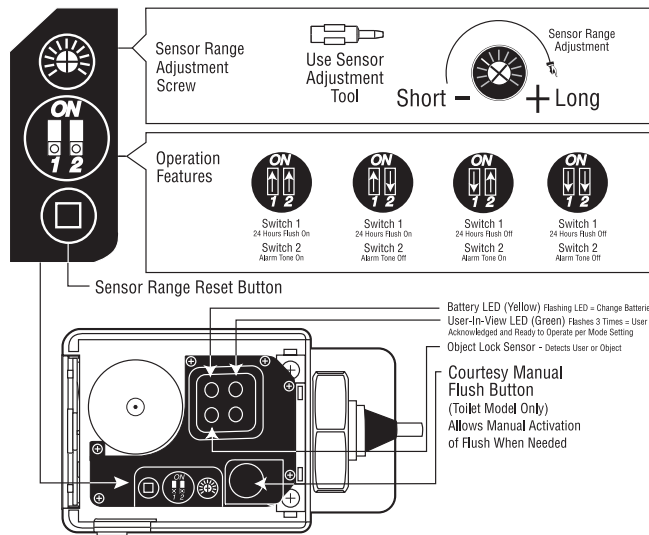

CARE AND CLEANING OF CHROME AND SPECIAL FINISHES

DO NOT USE abrasive or chemical cleaners to clean flushometers as they may dull the luster and attack the chrome or special decorative finishes. Use **ONLY** mild soap and water, then wipe dry with clean cloth or towel.

While cleaning the bathroom tile, the flushometer should be protected from any splattering of cleaner. Acids and cleaning fluids can discolor or remove chrome plating.

When assistance is required, please contact Sloan Technical Support at: 1-888-SLOAN-14 (1-888-756-2614).

Installation Instructions for GEM•2®

EBV-157-A Handle Adapter Kit

When converting a GEM•2® manual flushometer to a Sensor Activated flushometer with an SMO (Side Mount Operator), an EBV-157-A Handle Adapter kit must be used.

1. Remove handle assembly from flushometer.
2. Place Green "L" gasket over the hub in the SMO connection area.

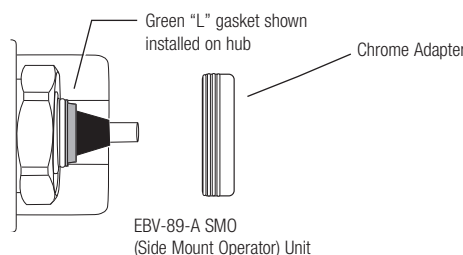

ECOS® Flushometers

Single-flush and Dual-flush

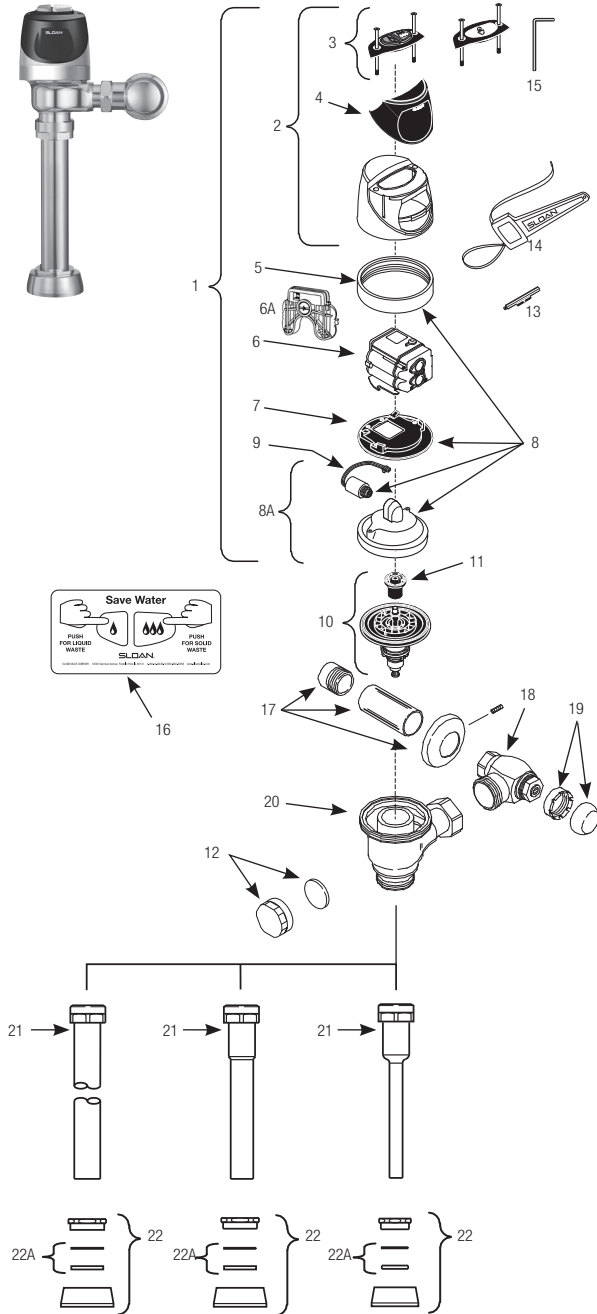

FLEX TUBE DIAPHRAGM ASSEMBLY

Sloan ECOS® Electronic Valve Models Feature Sloan's Exclusive flex tube diaphragm™ for the ultimate in valve performance, reliability and chloramine resistance.



The EBV-1020-A Kit is supplied with multiple Flush Volume Regulators. The installer must use the correct Regulator when installing the kit.†The brands and/or products names referenced herein may be subject to trademark rights of their respective owners. Use of the brands and names is for identification purposes only and does not imply affiliation with or endorsement by Sloan.

† Part No. varies with valve model variation; consult factory.

Item.	Code.	Part #	Description
Items Included with RESS Retrofit and Complete Sloan ECOS Flush Valves			
1.	0372055PK	WES-55-A	Cover/Ring/Sensor Assembly - Dual Flush WC
	0325160PK	EBV-138-A	Cover/Ring/Sensor Assembly - 1.6 & 1.28 gpf Single Flush WC
	—	EBV-378-A	Cover/Ring/Sensor Assembly - 1.1 gpf Single Flush WC
	0325161PK	EBV-139-A	Cover/Ring/Sensor Assembly - 1.0 gpf Single Flush Urinal
	0325341PK	EBV-341-A	Cover/Ring/Sensor Assembly - 0.25/0.5 gpf Single Flush
	0325389PK	EBV-381-A	Cover/Ring/Sensor Assembly - 0.125 gpf Single Flush
	0372060	WES-60-A	Cover/Ring/Sensor Assembly Dual Flush WC-fits Zurn* valve bodies
	0325166	EBV-149-A	Cover/Ring/Sensor Assembly 1.6 & 1.28 gpf Single Flush Water Closet-fits Zurn* valve bodies
	0325167PK	EBV-150-A	Cover/Ring/Sensor Assembly Single Flush Urinal fits Zurn* valve bodies
2.	0325246	EBV-191-A	Cover Assembly - Dual Flush
	0325168	EBV-142-A	Cover Assembly - Single Flush
3A.	0372033	WES-23-A	Button Cover Assembly with Screws - Dual Flush
	0325172	EBV-130-A	Button Cover Assembly with Screws - Single Flush
	0325242	EBV-182-A	Button Cover Assembly L/OR w/ Screws
3B.	0325170	EBV-132-A	Screws (2) and Hex Wrench Only
4.	0325169	EBV-131	Lens Window Cover
5.	0325804PK	EBV-14	Locking Ring
	3325524	EBV-31-A	Locking Ring - fits Zurn* valve bodies
6.	0325247	EBV-196-A	Module - ECOS Electronic 1.6/1.1 gpf Dual Flush
	—	EBV-383-A	Module - ECOS Electronic 1.1 gpf Single Flush
	3325450	EBV-129-AC	Module - ECOS Electronic 1.6 & 1.28 gpf Single Flush
	0325395PK	EBV-386 AU	Single Flush 0.125 gpf/0.5 Lpf
	0325396	EBV-387 AU	Single Flush 0.25 gpf/1.0 Lpf
	3325451	EBV-129-AU	Module - ECOS Electronic 0.5 & 1.0 gpf Single Flush
	33250045	EBV-386A-BT‡	Module - ECOS Electronic Urinal 0.125 gpf
6A.	33250011	—	Battery Door Replacement
7	0325171	EBV-134	Cover Rest Plate
8.	3325089	EBV-1010-A	Inner Cover Repair Kit (Metal)(includes solenoid & locking ring)
8A.	3325456	EBV-145-A	Inside Cover Assembly (includes solenoid)
9.	3325453	EBV-136-A	Solenoid
10	†	See next page	Flex Tube Diaphragm Assembly
11.	†	See next page	Flush Volume Regulator
12.	3325814	EBV-1017-A	Handle Cap (RESS Retrofit Models only)
13.	0325107PK	EBV-91	Screw Driver (Range Adjustment Tool)
14.	0305823	EBV-22	Strap Wrench
15.	0325159PK	EBV-137	7/64" Hex Wrench
16.	0372031	WES-19	English Operation Instruction Plate OBSELETE
	—	WES-22	Spanish Operation Instruction Plate OBSELETE
17.	3388015	H-1015	Flow Control Kit (HEU Only) (Not Shown)
Items Included with Complete Sloan ECOS Valves Only			
17A.	3308782	H-633-AA	1" (25 mm) Sweat Solder Kit
17B.	3308788	H-636-AA	¾" (20 mm) Sweat Solder Kit
18A.	0388000	H-700-A	1" (25 mm) Bak-Chek® Control Stop
18B.	0388001	H-700-A	¾" (20 mm) Bak-Chek® Control Stop
19	3308797	H-1010-A	Vandal Resistant Stop Cap
20.	0305381PK	EBV-36-A	Valve Body
Items Included with Complete Sloan ECOS Valves Only			
21A.	3393002	V-600-AA	1½" (38 mm) x 10 ½" (254 mm) Vacuum Breaker (Model 8110) (10" Outlet Tube)
	0323044	V-600-AA	1½" (38 mm) x 24 1/2" (622 mm) Vacuum Breaker (Model 8115)
	0393010	V-600-AA	1½" (38 mm) x 26" (660 mm) Vacuum Breaker (Model 8116)
21B.	0393046	V-600-AA	¾" (20 mm) x 10 ½" (254 mm) Vac Breaker (Model 8186) (10" Outlet Tube)
	0393039	V-600-AA	1¼" (31 mm) x 13½" (342 mm) Vac Breaker
22A.	0306146	F-5-AT	1½" Spud Coupling Assembly (Water Closet Models)
22B.	0306125	F-5-AW	¾" Spud Coupling Assembly (Urinal Models)

ECOS® Flushometers

Single-flush and Dual-flush

ITEM 10. FLEX TUBE DIAPHRAGM KIT SELECTION GUIDE

Code No.	Part No.	Description	Regulator Color
3325001	EBV-1020-A	1.6 gpf/6.0 Lpf Urinal	GREEN
3325003	EBV-1023-A	0.5 gpf/1.9 Lpf Urinal	GREEN
3325031	EBV-1024-A	1.28 gpf/4.8 Lpf Closet	GREEN
3325090	EBV-1025-A	0.125 gpf/0.5 Lpf or 0.25 gpf/ 1.0 Lpf Urinal	GREEN
3325121	EBV-1028-A	1.1 gpf/4.2 Lpf Closet	GRAY

EBV-1025-A includes H-1015A Flow Control

EBV-1020-A Kit is supplied with multiple Flush Volume Regulators. The installer must use the correct Regulator when installing the kit.

EBV-1020-A 1.6 gpf also for use for DF

ITEM 11. REGULATORS

The flush volume of the flex tube diaphragm kit is controlled by the regulator. Regulators are identified by color. Some flex tube diaphragm kits are supplied with multiple regulators. The installer must make sure the proper regulator is used when installing the flex tube diaphragm kit.

REGULATOR (SOLD 6 PER PACKAGE)

Code No.	Part No.	Description	Regulator Color
5325122	EBV-95	Urinal-0.5 gpf/1.9 Lpf	GREEN
5325122	EBV-95	Closet-1.28 gpf/4.8 Lpf	GREEN

FLEX TUBE DIAPHRAGM ASSEMBLY

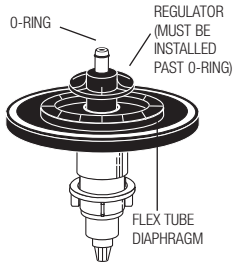

Sloan ECOS® models feature Sloan's exclusive flex tube diaphragm for the ultimate in valve performance, reliability and chloramine resistance.

ITEM 22A. SLIP JOINT GASKETS AND RINGS

Size	Code No.	Part No.	Description
1-1/2"	5306058	F-3	Red Friction Ring
	5322001	VBF-5	Black Slip Joint Gasket
	5319086	S-30	Flexible Seat
	0319079	S-21	Rigid Seat (rubber over brass)
1-1/2" x 1-1/4"	0396062	F-105	Slip Joint Gasket – Rigid
1-1/4"	5306057	F-3	Red Friction Ring
	5322176	VBF-5	Black Slip Joint Gasket
	0307052/5307052	G-21	Rigid Seat (rubber over brass)
1"	5306056	F-3	Red Friction Ring
	5306115	F-5	Black Slip Joint Gasket
3/4"	5306055	F-3	Red Friction Ring
	5306113	F-5	Black Slip Joint Gasket

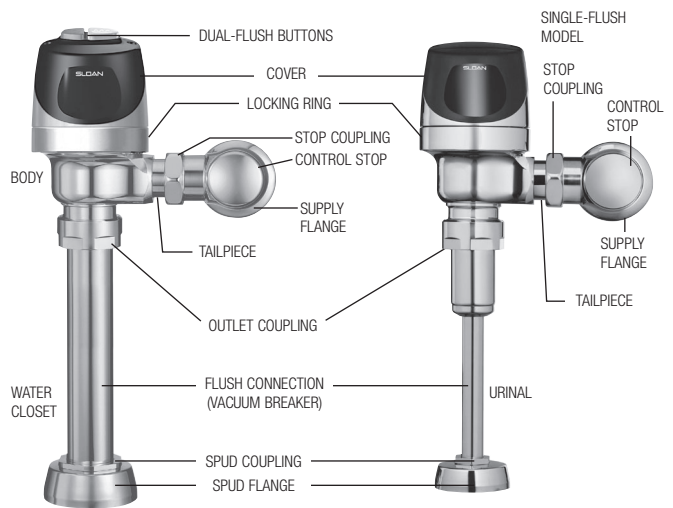

OPERATION

Manual Operation

Sloan ECOS® electronic dual-flush flushometers incorporate intuitive split-button design for easy manual activation. The small button controls the reduced flush cycle (1.1 gpf/4.2 Lpf), the large button controls the full flush cycle (1.6 gpf/6.0 Lpf). Straightforward graphics alert user to proper activation. Reduced flush for liquid waste, full flush for solid waste. To further educate the user, two (2) instructional wall plates are included with each Sloan ECOS dual-flush flushometer. For single-flush operation a single button is available for user's discretion.

Automatic Operation

Sloan ECOS electronic flushometers can also be activated via multi-lobular infrared sensor. By detecting user presence and duration, the Sloan ECOS Smart Sense Technology™ will determine the proper flush volume for unequalled water efficiency.

1. A continuous, INVISIBLE light beam is emitted from the Sloan ECOS sensor.
2. As the user enters the beam's effective range, 22 to 42 inches (559 mm to 1067 mm) for closet installations and 15 to 30 inches (381 mm to 762 mm) for urinal installations, the beam is reflected into the scanner window to activate the output circuit. Once activated, the output circuit continues in a "hold" mode for as long as the user remains within the effective range of the sensor. For dual-flush models, if the user stays longer than 65 seconds, a full flush will automatically initiate when the user leaves. For single-flush models, once the user steps away, a full flush will automatically initiate.
3. For a dual-flush model, once a user is detected, if the user leaves in 65 seconds or less, a reduced flush will automatically initiate. The circuit automatically resets and is ready for the next user. For a single-flush model, when the user steps away, this initiates a full flush. The circuit automatically resets and is ready for the next user.

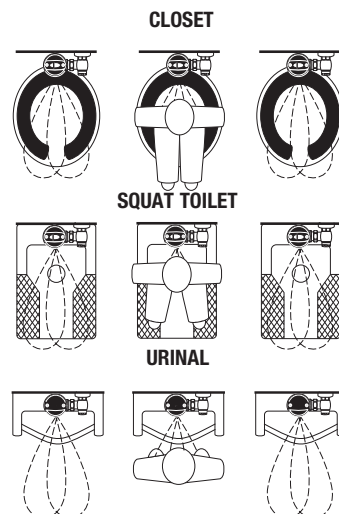

ECOS® Flushometers

Single-flush and Dual-flush

BATTERY REPLACEMENT

When required, replace batteries with four (4) AA-Size Batteries.

Note: Water DOES NOT have to be turned off to replace batteries.

Loosen the two (2) screws on top of unit. Remove the complete cover assembly. Lift the sensor module from its plate. Unplug the electrical connector from battery compartment cover. Loosen the retaining screw on battery compartment cover and remove battery compartment cover. Install four (4) alkaline type AA batteries **exactly** as illustrated at right.

Install battery compartment cover and secure with retaining screw. Make certain that battery compartment cover is fully compressed against gasket to provide a seal; **DO NOT** overtighten. Plug the electrical connector into the battery compartment cover. Reinstall the sensor module onto the plate. Reinstall the complete cover assembly onto the plate. Tighten the two (2) screws on top of the unit.

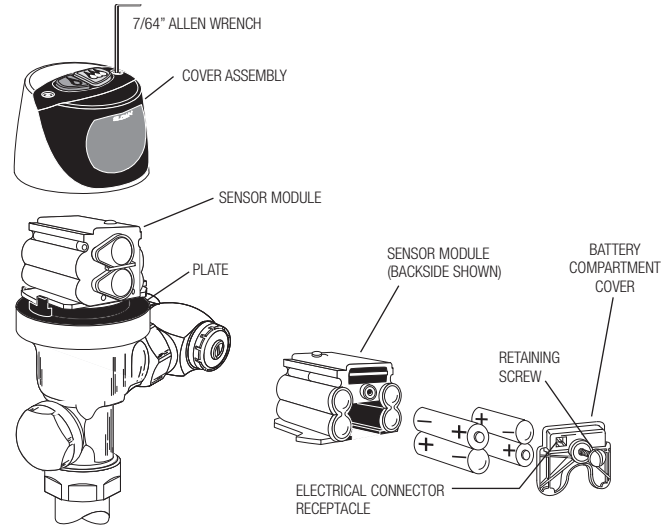

RANGE ADJUSTMENT (ADJUST ONLY IF NECESSARY)

The Sloan ECOS® electronic flushometer has a factory set sensing range:

Water closet models – 22” to 42” (559 mm to 1067 mm)

Urinal models – 15” to 30” (381 mm to 762 mm)

The Factory setting should be satisfactory for most installations.

If the range is too short (i.e., not picking up users) or too long (i.e., picking up opposite wall or stall door) the range can be adjusted.

Note: Water DOES NOT have to be turned off to adjust range.

Loosen the two screws on top of the unit. Remove the override button. Remove the rubber plug from top of electronic sensor module to uncover the potentiometer.

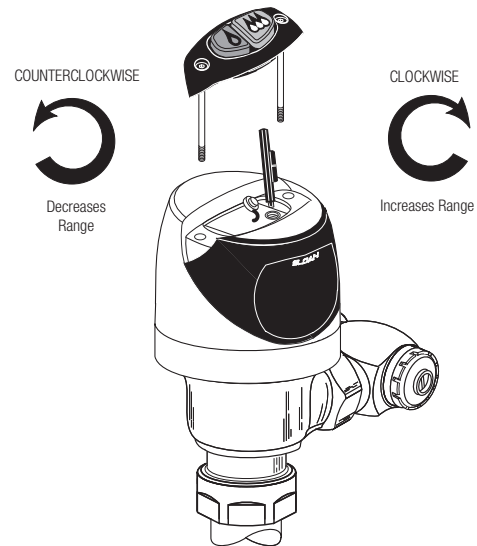

RANGE ADJUSTMENT PROCEDURE

For the first ten (10) minutes of operation, a visible light flashes in the sensing window of the Sloan ECOS electronic flushometer when a user is detected. This visible light feature can be reactivated after ten (10) minutes by opening and closing the battery compartment door.

Check the range by stepping toward the unit until the light flashes, indicating the sensor's maximum detection limit. Adjust the range potentiometer screw located on top of the sensor module a few degrees **CLOCKWISE** to increase the range or a few degrees **COUNTERCLOCKWISE** to decrease the range. Repeat this adjustment until the desired range is achieved.

Always determine the sensing range with metal cover and lens window on top of the unit.

IMPORTANT: Adjust in small increments only! Range potentiometer adjustment screw rotates only 3/4 of a turn; DO NOT over-tighten.

When range adjustment is satisfactory, replace the rubber plug. Reinstall override button and tighten the two screws on top of the unit.

ECOS® Flushometers

Single-flush and Dual-flush

TROUBLESHOOTING AND MAINTAINING THE SLOAN ECOS® FLUSHOMETER

1. Sensor flashes continuously only when user steps within range.

- A. Unit in start-up mode; no problem. This feature is active for the first ten (10) minutes of operation.

2. Valve DOES NOT flush; sensor not picking up user.

- A. Range too short; increase the range.

3. Valve DOES NOT flush; sensor picking up opposite wall or surface, or only flushes when someone walks by. Light flashes continuously for first 10 minutes even with no one in front of the sensor.

- A. Range too long; shorten range.

4. Valve DOES NOT flush even after adjustment.

- A. Range adjustment potentiometer set at full "max" or full "min" setting. Readjust potentiometer away from full "max" or "min" setting.
- B. Batteries completely used up; replace batteries.
- C. Problem with electronic sensor module; replace electronic sensor module.

5. Unit flashes 4 Quick Times When User Steps within range.

- A. Batteries low; replace batteries.

6. Valve DOES NOT shut off.

- A. Bypass orifice in diaphragm is clogged with dirt or debris, or bypass is clogged by an invisible gelatinous film due to "over-treated" water. Remove flex tube diaphragm and wash under running water.

Note: Size of orifice in the bypass is of utmost importance for the proper metering of water by the valve. **DO NOT ENLARGE OR DAMAGE THIS ORIFICE.** Replace flex tube diaphragm if cleaning does not correct the problem.

- B. Dirt or debris fouling stem or flex tube diaphragm. Remove flex tube diaphragm and wash under running water.
- C. O-ring on stem of flex tube diaphragm is damaged or worn. Replace O-ring if necessary.
- D. Problem with electronic sensor module; replace sensor module.

7. Not enough water to fixture.

- A. Wrong flush volume regulator installed in flex tube diaphragm kit. Install the correct regulator.
- B. Wrong Sloan ECOS electronic model installed; i.e., 1.6 gpf/1.1 gpf model installed on 3.5 gal. closet fixture.
- C. Enlarged bypass in diaphragm. Replace flex tube diaphragm.
- D. Control stop not adjusted properly. Readjust control stop.
- E. Inadequate volume or pressure at supply. Increase water pressure or supply (flow) to valve. Consult factory for assistance.

8. Too much water to fixture.

- A. Wrong flush volume regulator installed in flex tube diaphragm kit. Install the correct regulator (see Step 7 of these instructions).
- B. Control stop not adjusted properly. Readjust control stop.
- C. Wrong Sloan ECOS model installed; i.e., 0.5 gpf model installed on 0.125 gal. fixture. Replace with proper Sloan ECOS electronic model.
- D. Dirt in diaphragm bypass. Clean under running water or replace flex tube diaphragm.

Note: The EBV-46-A Beam Deflector is no longer required or available for the Sloan ECOS.

CARE AND CLEANING INSTRUCTIONS

DO NOT USE abrasive or chemical cleaners to clean the flushometer as they may dull the luster and attack the plastic cover and the chrome finish of the flushometer. Use **ONLY** mild soap and water, then wipe dry with clean cloth or towel.

While cleaning the bathroom tile, the flushometer should be protected from any splattering of cleaner. Acids and cleaning fluids can discolor or remove chrome plating.

When assistance is required, please contact Sloan Technical Support at: 1-888-SLOAN-14 (1-888-756-2614).

SOLIS® Flushometers

Single-flush and Dual-flush

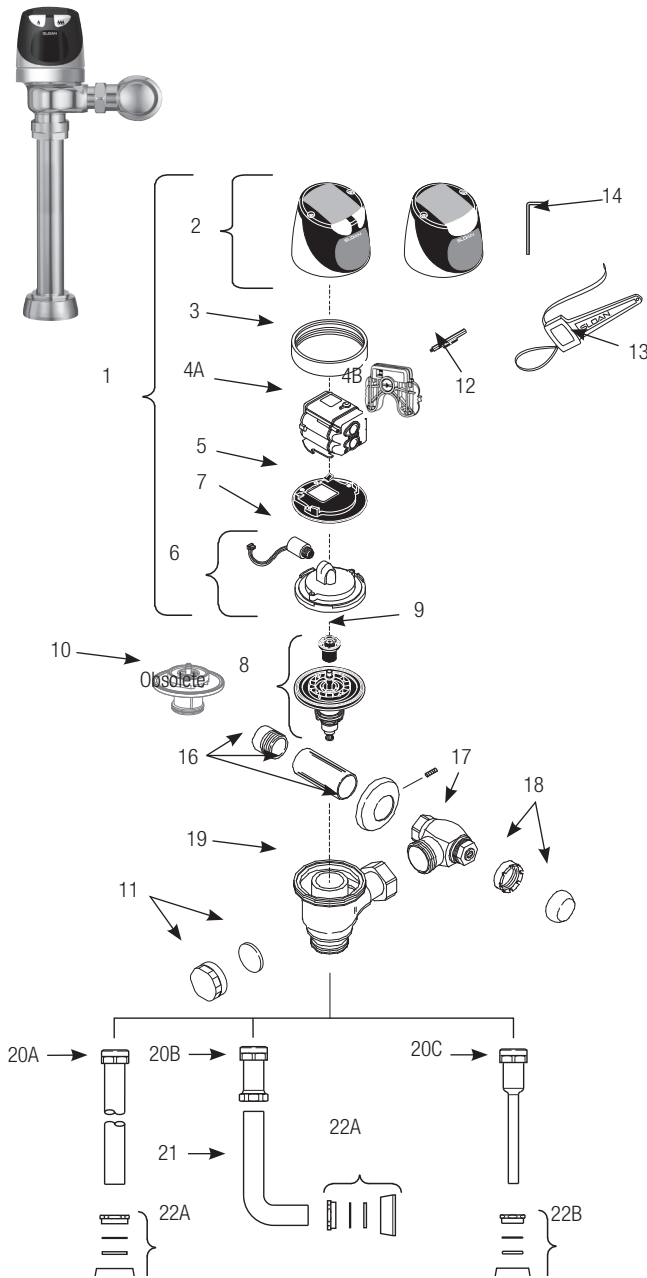

Item.	Code.	Part.	Description
Items Included with RESS Retrofit and Complete Sloan SOLIS® Valves			
1.	0325300	EBV-304-A	Cover/Sensor/Assembly - Closet SOLIS 1.6 & 1.28 gpf Electronic Single Button Flush
		EBV-379-A	Cover/Sensor/Assembly - Closet SOLIS 1.1 gpf Electronic Single Button Flush
	0372024	WES-24-A	Cover/Sensor/Assembly Closet SOLIS Electronic Dual Flush
	0325301	EBV-306-A	Cover/Sensor/Assembly - Urinal 0.5 & 1.0 gpf SOLIS Electronic Single Button
	0325328	EBV-328-A	Cover/Sensor/Assembly - Urinal 0.25 gpf SOLIS Electronic Single Button
	0325394	EBV-385-A	Cover/Sensor/Assembly - Urinal 0.125 gpf SOLIS Electronic Single Button
	0325320	EBV-320-A	Cover/Sensor/Assembly - Closet 1.6 & 1.28 gpf SOLIS Electronic Single Button Flush fits Zurn® valve bodies
	0372028	WES-28-A	Cover/Sensor/Assembly- Closet SOLIS Electronic Dual Flush - fits Zurn® valve bodies
	0325321	EBV-321-A	Cover/Sensor/Assembly Urinal 0.25 gpf SOLIS Electronic Single Button - fits Zurn® valve bodies
2.	0325311	EBV-311-A	Cover Assembly - SOLIS Electronic Dual Flush Flush
	0325309	EBV-309-A	Cover Assembly - SOLIS Electronic Single Button Flush
3.	0325804	EBV-14	Locking Ring
	0305843	EBV-30	Locking Ring- fits Zurn® valve bodies
4A.	0325312	EBV-312-A-C	Module - SOLIS - Water Closet
	0325313	EBV-312-A-U	Module - SOLIS - Urinal
	0325397	EBV-388-A	Module - SOLIS - Urinal 0.125 gpf
	—	EBV-382-A	Module - SOLIS - 1.1 gpf Single Button Flush
	0372038	WES-33-A	Module - SOLIS - Water Closet (Dual Flush)
4B.	03250011	EBV Repair Kit	Battery Cover Door
5.	0325171	EBV-134	Cover Rest Plate
6.	3325456	EBV-145-A	Inside Cover Assembly (includes solenoid)
7.	3325453	EBV-136-A	Solenoid
8.	† See Next Page		Flex Tube Diaphragm Assembly
9.	† See Next Page		Flush Volume Regulator
10.	† See Next Page		Cartridge Assembly DISCONTINUED
11.	3325814	EBV-1017-A	Handle Cap (RESS Retrofit Models Only)
12.	0325107	EBV-91	Range Adjustment Tool
13.	0305823	EBV-22	Strap Wrench
14.	0325159	EBV-137	7/64" Hex Wrench
	0372029	WES-27	English Plate (Dual Flush only) DISCONTINUED
	0372025	WES-29	Spanish Plate (Dual Flush only) DISCONTINUED
Items Included with Complete Sloan SOLIS® Valves Only			
16.	3308782	H-633-AA	1" (25 mm) Sweat Solder Kit
	3308788	H-636-AA	¾" (19 mm) Sweat Solder Kit
17.	3308386	H-700-A	1" (25 mm) Bak-Chek® Control Stop
	3308384	H-700-A	¾" (19 mm) Bak-Chek® Control Stop
18.	3308772	H-1010-A	Vandal Resistant Stop Cap
19.	0305381	EBV-36-A	Valve Body
20A.	—	V-600-AA	1½" (38 mm) x 10 ½" (229 mm) Vacuum Breaker (Model 8111) (10" Outlet Tube)
	—	V-600-AA	1½" (38 mm) x 15" (584 mm) Vacuum Breaker (Model 8113)
	—	V-600-AA	1½" (38 mm) x 23" (584 mm) Vacuum Breaker (Model 8115)
	—	V-600-AA	1½" (38 mm) x 26" (660 mm) Vacuum Breaker (Model 8116)
20B.	—	V-600-A	3" (76 mm) Vacuum Breaker Assembly
20C.	—	V-600-AA	¾" (19 mm) x 10½" (229 mm) Vacuum Breaker (Model 8186) (10" Outlet Tube)
21.	—	F-109	1½" (38 mm) Elbow Flush Connection
22A.	0306146	F-5-AT	1½" Spud Coupling Assembly (Models 8110, 8110 8115 & 8116)
22B.	0306125	F-5-AW	¾" Spud Coupling Assembly (Model 8186)

† Part No. varies depending on flushometer model.
 Manufactured in the U.S.A. by Sloan Valve Company under one or more of the following patents: U.S. Patents: D598,975; D599,436; 7,124,997. Other Patents Pending.
 BAK-CHEK®, PARA-FLO®, PERMEX®, TURBO-FLO®.

†The brands and/or products names referenced herein may be subject to trademark rights of their respective owners. Use of the brands and names is for identification purposes only and does not imply affiliation with or endorsement by Sloan.

SOLIS® Flushometers

Single-flush and Dual-flush

ITEM 8. FLEX TUBE DIAPHRAGM KIT SELECTION GUIDE

Code No.	Part No.	Description	Regulator Color
3325001	EBV-1020-A	1.6 gpf/6.0 Lpf Closet	GREEN
3325031	EBV-1024-A	1.28 gpf/4.8 Lpf Closet	GREEN
—	EBV-1028-A	1.1 gpf/4.2 Lpf Closet	GRAY
3325003	EBV-1023-A	0.5 gpf/1.9 Lpf Urinal	GREEN
3325090	EBV-1025-A	0.25 gpf/1.0 Lpf Urinal	GREEN

The EBV-1020-A Kit is supplied with multiple Flush Volume Regulators. The installer must use the correct Regulator when installing the kit.

EBV-1025-A includes H-1015A Flow Control

ITEM 9. REGULATORS

The flush volume of the flex tube diaphragm kit is controlled by the regulator. Regulators are identified by color. Some flex tube diaphragm kits are supplied with multiple regulators. The installer must make sure the proper regulator is used when installing the flex tube diaphragm kit.

REGULATOR (SOLD 6 PER PACKAGE)

Code No.	Part No.	Description	Regulator Color
5325122	EBV-95	Urinal-0.5 gpf/1.9 Lpf	GREEN
5325122	EBV-95	Closet-1.6 gpf/6.0 Lpf	GREEN

FLEX TUBE DIAPHRAGM ASSEMBLY

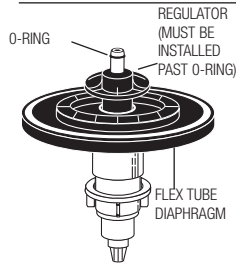

SOLIS models feature Sloan's exclusive flex tube diaphragm for the ultimate in valve performance, reliability and chloramine resistance.

SLIP JOINT GASKETS AND RINGS

Size	Code No.	Part No.	Description
1-1/2"	5306058	F-3	Red Friction Ring
	5322001	VBF-5	Black Slip Joint Gasket
	0319086/5319086	S-30	Flexible Seat
	0319079	S-21	Rigid Seat (rubber over brass)
1-1/2" x 1-1/4"	0396062	F-105	Slip Joint Gasket – Rigid
1-1/4"	5306057	F-3	Red Friction Ring
	5322176	VBF-5	Black Slip Joint Gasket
	0307052/5307052	G-21	Rigid Seat (rubber over brass)
1"	5306056	F-3	Red Friction Ring
	5306115	F-5	Black Slip Joint Gasket
3/4"	5306055	F-3	Red Friction Ring
	5306113	F-5	Black Slip Joint Gasket

OPERATION

1. A continuous, invisible light beam is emitted from the SOLIS® sensor.

2. As the user enters the beam's effective range, 22 to 42 inches (559 mm to 1067 mm) for closet installations and 15 to 30 inches (381 mm to 762 mm) for urinal installations, the beam is reflected into the scanner window to activate the output circuit. Once activated, the output circuit continues in a "hold" mode for as long as the user remains within the effective range of the sensor. For dual-flush models, if the user stays longer than 65 seconds, a full flush will automatically initiate when the user leaves. For single-flush models, once the user steps away, a full flush will automatically initiate.

3. For dual-flush models, once a user is detected, if the user leaves in 65 seconds or less, a reduced flush will automatically initiate. The circuit automatically resets and is ready for the next user. For single-flush models, when the user steps away, this initiates a full flush. The circuit automatically resets and is ready for the next user.

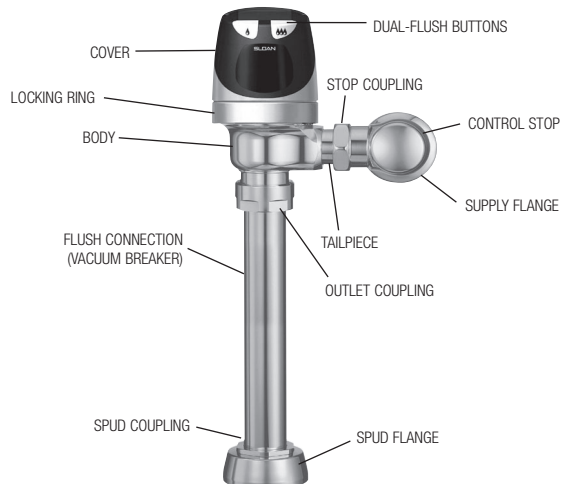
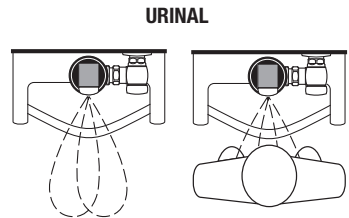
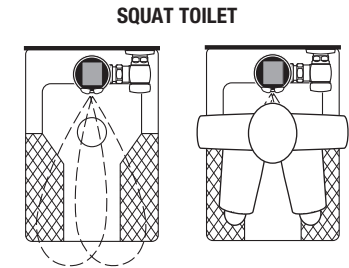
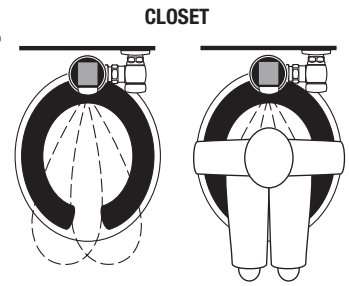

SOLIS® Flushometers

Single-flush and Dual-flush

BATTERY REPLACEMENT

When required, replace batteries with four (4) AA-size batteries.

Note: Water DOES NOT have to be turned off to replace batteries.

Loosen the two (2) screws on top of unit. Remove the complete cover assembly. Lift the sensor module from its plate. Unplug the electrical connector from battery compartment cover. Loosen the retaining screw on battery compartment cover and remove battery compartment cover. Install four (4) AA-size batteries **exactly** as illustrated.

Install battery compartment cover and secure with retaining screw. Make certain that battery compartment cover is fully compressed against gasket to provide a seal; **DO NOT** overtighten. Plug the electrical connector into the battery compartment cover. Reinstall the sensor module onto the plate. Reinstall the complete Cover Assembly onto the plate. Tighten the two (2) screws on top of the unit.

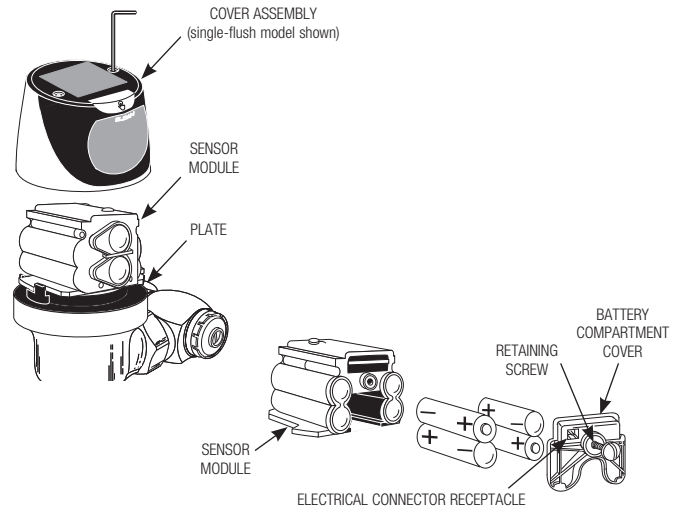

RANGE ADJUSTMENT (ADJUST ONLY IF NECESSARY)

The SOLIS® has a factory set sensing range:

Water Closet Models - 22" to 42" (559 mm to 1067 mm)

Urinal Models - 15" to 30" (381 mm to 762 mm)

The Factory setting should be satisfactory for most installations.

If the range is too short (i.e., not picking up users) or too long (i.e., picking up opposite wall or stall door) the range can be adjusted.

Note: Water DOES NOT have to be turned off to adjust range.

Loosen the two screws on top of the unit and remove cover. Remove the rubber plug from top of electronic sensor module to uncover the potentiometer.

RANGE ADJUSTMENT PROCEDURE

For the first ten (10) minutes of operation, a visible light flashes in the sensing window of the SOLIS® flushometer when a user is detected. This visible light feature can be reactivated after ten (10) minutes by opening and closing the battery compartment door.

Check the range by stepping toward the unit until the light flashes, indicating the sensor's maximum detection limit. Adjust the range potentiometer screw located on top of the sensor module a few degrees **CLOCKWISE** to increase the range or a few degrees **COUNTERCLOCKWISE** to decrease the range. Repeat this adjustment until the desired range is achieved.

Always determine the sensing range with metal cover and lens window on top of the unit.

IMPORTANT: Adjust in small increments only! Range potentiometer adjustment screw rotates only 3/4 of a turn; DO NOT over-tighten.

When range adjustment is satisfactory, replace the Rubber Plug. Reinstall Cover and tighten the two Screws on top of the unit.

IMPORTANT: Adjust in small increments only! Range potentiometer adjustment screw rotates only 3/4 of a turn; DO NOT over-rotate.

When range adjustment is satisfactory, replace the rubber plug. Reinstall cover and tighten the two screws on top of the unit.

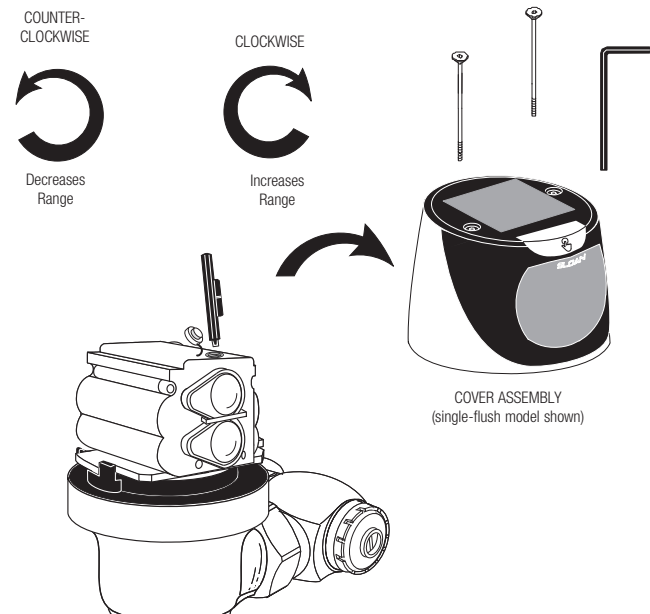

SOLIS® Bluetooth (BT) Flushometers

Single-flush and Dual-flush

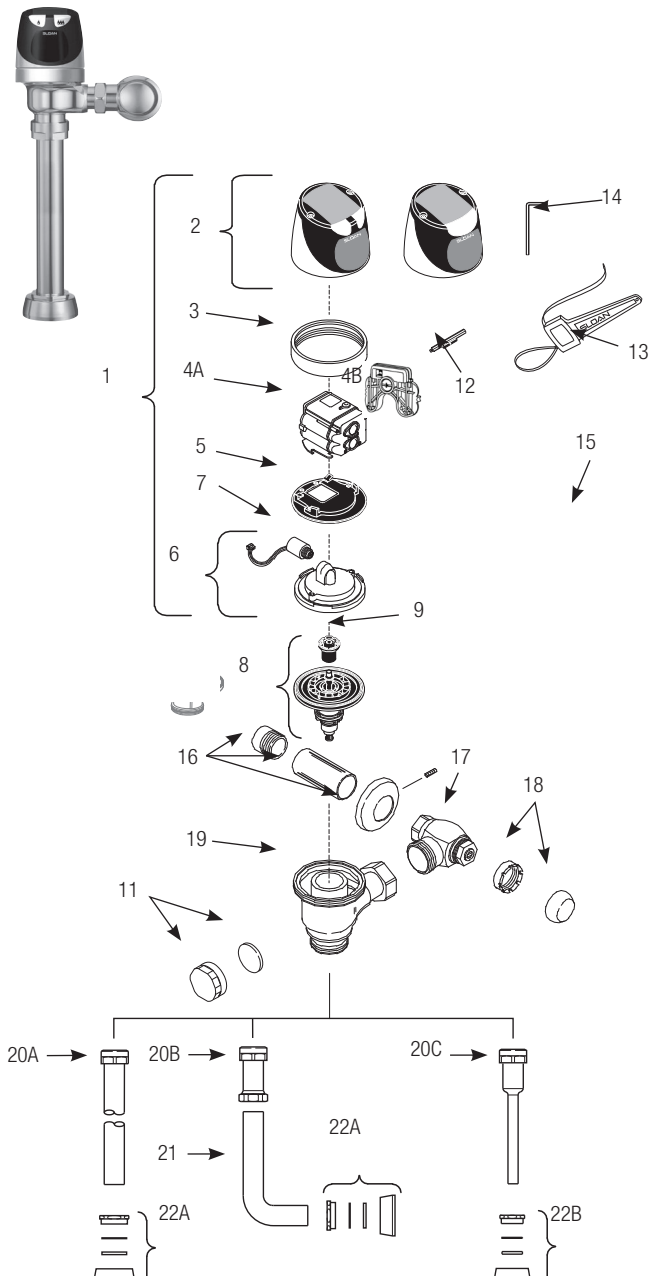

Items Included with RESS Retrofit and Complete Sloan SOLIS® Valves

1.	03250002	EBV-304A-BT	Cover/Sensor/Assembly - Closet SOLIS 1.28 gpf Electronic Single Button Flush
	03250001	EBV-304A-BT	Cover/Sensor/Assembly - Closet SOLIS Electronic Single Button Flush 1.6 gpf
	03250005	EBV-306A-BT	Cover/Sensor/Assembly - Urinal 0.25 gpf SOLIS Electronic Single Button
	03250006	EBV-306A-BT	Cover/Sensor/Assembly - Urinal 0.5 gpf SOLIS Electronic Single Button
	03250007	EBV-306A-BT	Cover/Sensor/Assembly - Urinal 0.1 gpf SOLIS Electronic Single Button
	03250003	EBV-379A-BT	Cover/Sensor/Assembly - Closet SOLIS Electronic Single Button Flush 1.1 gpf
	03250004	EBV-385A-BT	Cover/Sensor/Assembly - Closet SOLIS Electronic Single Button Flush 0.125 gpf
2.	0325311	EBV-311-A	Cover Assembly - SOLIS Electronic Dual Flush Flush
	0325309	EBV-309-A	Cover Assembly - SOLIS Electronic Single Button Flush
3.	0325804	EBV-14	Locking Ring
	0305843	EBV-30	Locking Ring- fits Zurn® valve bodies
4A.	33250006	EBV-312A-BT	Module - SOLIS - Urinal 0.5 gpf
	33250007	EBV-312A-BT	Module - SOLIS - Urinal 1.0 gpf
	33250002	EBV-312A-BT	Module - SOLIS - Water Closet 1.28 gpf gpf
	33250001	EBV-312A-BT	Module - SOLIS - Water Closet 1.6 gpf gpf
	33250003	EBV-382A-BT	Module - SOLIS - Water Closet 1.1 gpf gpf
	33250004	EBV-388A-BT	Module - SOLIS - Urinal 0.125 gpf
	33250005	EBV-389A-BT	Module - SOLIS - Urinal 0.25 gpf gpf
4B.	33250011	EBV Repair Kit	Battery Cover Door
5.	0325171	EBV-134	Cover Rest Plate
6.	3325456	EBV-145-A	Inside Cover Assembly (includes solenoid)
7.	3325453	EBV-136-A	Solenoid
8.	†	See Next Page	Flex Tube Diaphragm Assembly
9.	†	See Next Page	Flush Volume Regulator
11.	3325814	EBV-1017-A	Handle Cap (RESS Retrofit Models Only)
12.	0325107	EBV-91	Range Adjustment Tool
13.	0305823	EBV-22	Strap Wrench
14.	0325159	EBV-137	7/64" Hex Wrench
15.	0372029	WES-27	English Plate (Dual Flush only) DISCONTINUED
	0372025	WES-29	Spanish Plate (Dual Flush only) DISCONTINUED

Items Included with Complete Sloan SOLIS® Valves Only

16.	3308782	H-633-AA	1" (25 mm) Sweat Solder Kit
	3308788	H-636-AA	¾" (19 mm) Sweat Solder Kit
17.	3308386	H-700-A	1" (25 mm) Bak-Chek® Control Stop
	3308384	H-700-A	¾" (19 mm) Bak-Chek® Control Stop
18.	3308772	H-1010-A	Vandal Resistant Stop Cap
19.	0305381	EBV-36-A	Valve Body
20A.	—	V-600-AA	1½" (38 mm) x 10½" (229 mm) Vacuum Breaker (Model 8111)
	—	V-600-AA	1½" (38 mm) x 15" (584 mm) Vacuum Breaker (Model 8113)
	—	V-600-AA	1½" (38 mm) x 23" (584 mm) Vacuum Breaker (Model 8115)
	—	V-600-AA	1½" (38 mm) x 26" (660 mm) Vacuum Breaker (Model 8116)
20B.	—	V-600-A	3" (76 mm) Vacuum Breaker Assembly
20C.	—	V-600-AA	¾" (19 mm) x 10½" (229 mm) Vacuum Breaker (Model 8186)
21.	—	F-109	1½" (38 mm) Elbow Flush Connection
22A.	0306146	F-5-AT	1½" Spud Coupling Assembly (Models 8110, 8110 8115 & 8116)
22B.	0306125	F-5-AW	¾" Spud Coupling Assembly (Model 8186)

† Part No. varies depending on flushometer model.

Manufactured in the U.S.A. by Sloan Valve Company under one or more of the following patents: U.S. Patents: D598,975; D599,436; 7,124,997. Other Patents Pending. BAK-CHEK®, PARA-FLO®, PERMEX®, TURBO-FLO®.

*Zurn® is a registered trademark of Zurnco, Inc. Use of "Zurn" is for identification purposes only and does not imply affiliation, endorsement, or association between Sloan and Zurnco, Inc.

SOLIS® Bluetooth (BT) Flushometers Single-flush and Dual-flush

ITEM 8. FLEX TUBE DIAPHRAGM KIT SELECTION GUIDE

Code No.	Part No.	Description	Regulator Color
3325001	EBV-1020-A	1.6 gpf/6.0 Lpf Closet	GREEN
3325031	EBV-1024-A	1.28 gpf/4.8 Lpf Closet	GREEN
—	EBV-1028-A	1.1 gpf/4.2 Lpf Closet	GRAY
3325003	EBV-1023-A	0.5 gpf/1.9 Lpf Urinal	GREEN
3325090	EBV-1025-A	0.25 gpf/10 Lpf Urinal	GREEN

The EBV-1020-A Kit is supplied with multiple Flush Volume Regulators. The installer must use the correct Regulator when installing the kit.

EBV-1025-A includes H-1015A Flow Control

ITEM 9. REGULATORS

The flush volume of the flex tube diaphragm kit is controlled by the regulator. Regulators are identified by color. Some flex tube diaphragm kits are supplied with multiple regulators. The installer must make sure the proper regulator is used when installing the flex tube diaphragm kit.

REGULATOR (SOLD 6 PER PACKAGE)

Code No.	Part No.	Description	Regulator Color
5325122	EBV-95	Urinal-0.5 gpf/1.9 Lpf	GREEN
5325122	EBV-95	Closet-1.6 gpf/6.0 Lpf	GREEN

FLEX TUBE DIAPHRAGM ASSEMBLY

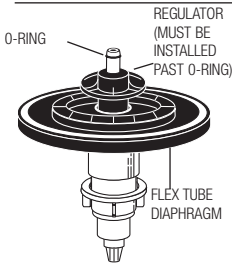

SOLIS models feature Sloan's exclusive flex tube diaphragm for the ultimate in valve performance, reliability and chloramine resistance.

SLIP JOINT GASKETS AND RINGS

Size	Code No.	Part No.	Description
1-1/2"	5306058	F-3	Red Friction Ring
	5322001	VBF-5	Black Slip Joint Gasket
	0319086/5319086	S-30	Flexible Seat
	0319079	S-21	Rigid Seat (rubber over brass)
1-1/2" x 1-1/4"	0396062	F-105	Slip Joint Gasket – Rigid
1-1/4"	5306057	F-3	Red Friction Ring
	5322176	VBF-5	Black Slip Joint Gasket
	0307052/5307052	G-21	Rigid Seat (rubber over brass)
1"	5306056	F-3	Red Friction Ring
	5306115	F-5	Black Slip Joint Gasket
3/4"	5306055	F-3	Red Friction Ring
	5306113	F-5	Black Slip Joint Gasket

OPERATION

1. A continuous, INVISIBLE light beam is emitted from the SOLIS® sensor.

2. As the user enters the beam's effective range, 22 to 42 inches (559 mm to 1067 mm) for closet installations and 15 to 30 inches (381 mm to 762 mm) for urinal installations, the beam is reflected into the scanner window to activate the output circuit. Once activated, the output circuit continues in a "hold" mode for as long as the user remains within the effective range of the sensor. For dual-flush models, if the user stays longer than 65 seconds, a full flush will automatically initiate when the user leaves. For single-flush models, once the user steps away, a full flush will automatically initiate.

3. For dual-flush models, once a user is detected, if the user leaves in 65 seconds or less, a reduced flush will automatically initiate. The circuit automatically resets and is ready for the next user. For single-flush models, when the user steps away, this initiates a full flush. The circuit automatically resets and is ready for the next user.

CLOSET

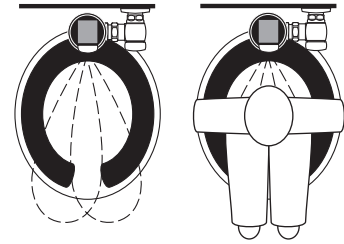

SQUAT TOILET

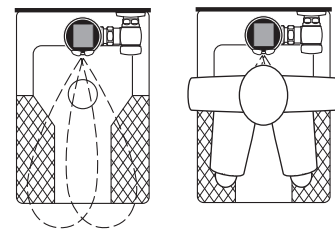

URINAL

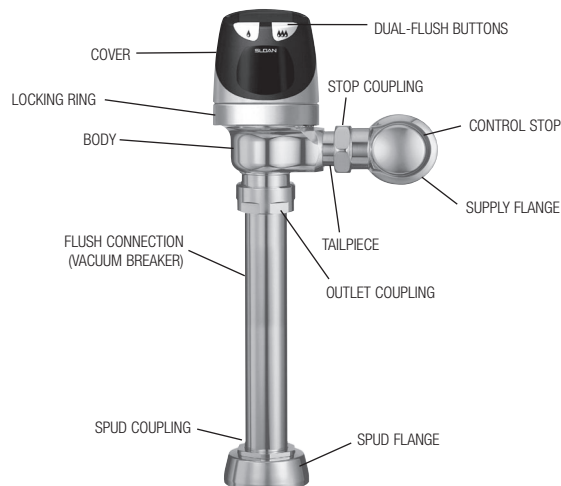
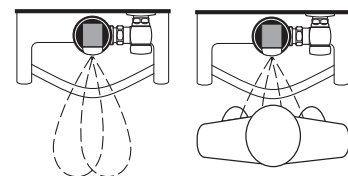

SOLIS® Flushometers

Single-flush and Dual-flush

TROUBLESHOOTING GUIDE

1. Sensor flashes continuously only when user steps within range.

- A. Unit in start-up mode; no problem. This feature is active for the first ten (10) minutes of operation.

2. Valve DOES NOT flush; sensor not picking up user.

- A. Range too short; increase the range.

3. Valve DOES NOT flush; sensor picking up opposite wall or surface, or only flushes when someone walks by. Light flashes continuously for first 10 minutes even with no one in front of the sensor.

- A. Range too long; shorten range.

4. Valve DOES NOT flush even after adjustment.

- A. Range adjustment potentiometer set at full "max" or full "min" setting. Readjust potentiometer away from full "max" or "min" setting.
- B. Batteries completely used up; replace batteries.
- C. Problem with electronic sensor module; replace electronic sensor module.

5. Unit flashes 4 quick times when user steps within range.

- A. Batteries low; replace batteries.

6. Valve DOES NOT shut off.

- A. Bypass orifice in diaphragm is clogged with dirt or debris, or bypass is clogged by an invisible gelatinous film due to "over-treated" water. Remove flex tube diaphragm and wash under running water.

Note: Size of orifice in the bypass is of utmost importance for the proper metering of water by the valve. DO NOT ENLARGE OR DAMAGE THIS ORIFICE. Replace flex tube diaphragm if cleaning does not correct the problem.

- B. Dirt or debris fouling stem or flex tube diaphragm. Remove flex tube diaphragm and wash under running water.
- C. O-ring on stem of flex tube diaphragm is damaged or worn. Replace O-ring if necessary.
- D. Problem with electronic sensor module; replace sensor module.

7. Not enough water to fixture.

- A. Wrong flush volume regulator installed in flex tube diaphragm kit. Install the correct regulator.
- B. Wrong SOLIS® model installed; i.e., 1 gpf. Urinal installed on 3.5 gal. closet fixture. Replace with proper SOLIS® model.
- C. Enlarged bypass in diaphragm. Replace flex tube diaphragm.
- D. Control stop not adjusted properly. Readjust control stop.
- E. Inadequate volume or pressure at supply. Increase water pressure or supply (flow) to valve. Consult factory for assistance.

8. Too much water to fixture.

- A. Wrong flush volume regulator installed in flex tube diaphragm kit. Install the correct regulator.
- B. Control stop not adjusted properly. Readjust control stop.
- C. Wrong SOLIS model installed; i.e., 3 gpf. model installed on 1.0 or 1.5 gal. Urinal fixture. Replace with proper SOLIS mode.
- D. Dirt in diaphragm bypass. Clean under running water or replace flex tube diaphragm.

Note: The EBV-46-A beam deflector is not required or available for the SOLIS®.

CARE AND CLEANING INSTRUCTIONS

DO NOT USE abrasive or chemical cleaners to clean flushometers as they may dull the luster and attack the chrome or special decorative finishes. Use **ONLY** soap and water, then wipe dry with clean cloth or towel.

While cleaning the bathroom tile, the flushometer should be protected from any splattering of cleaner. Acids and cleaning fluids can discolor or remove chrome plating.

When assistance is required, please contact Sloan Technical Support at: 1-888-SLOAN-14 (1-888-756-2614).

Concealed SOLIS® Flushometer

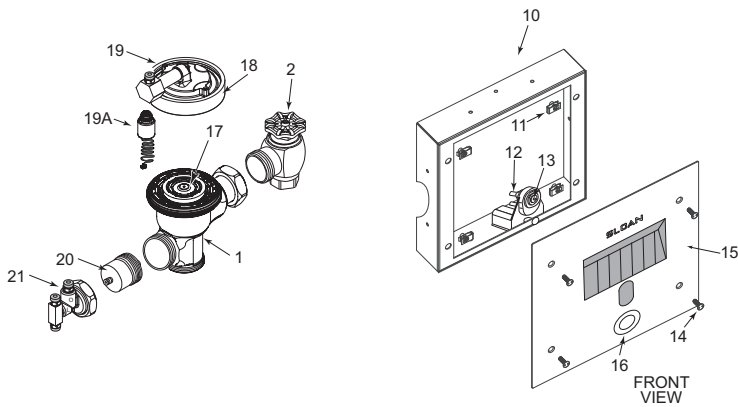
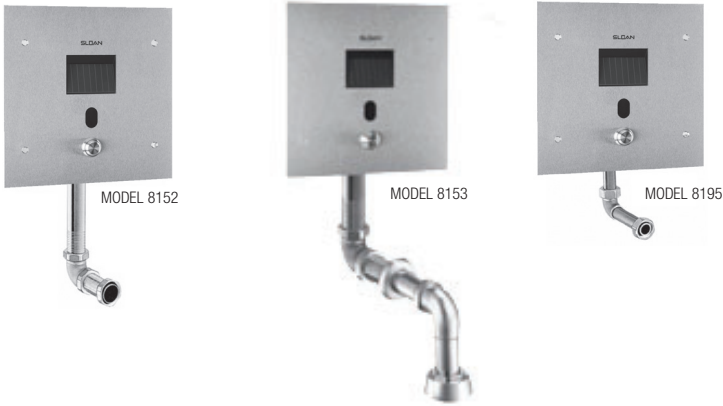

SOLIS 8152 SWB

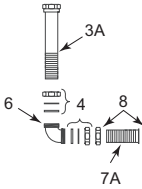

SOLIS 8153 SWB

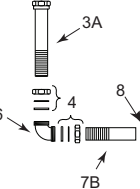

SOLIS 8195 SWB

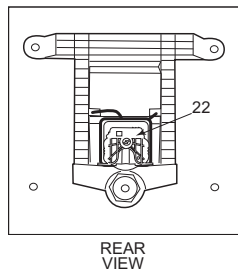
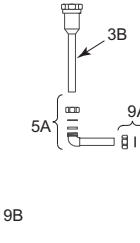

PARTS LIST

Item No.	Code No.	Part No.	Description
1.	0301050	A-143-A	RB Hydraulic Valve Body
2.	0388010	H-730-A	RB Bak-Chek® 1" Control Stop
	0388011	H-730-A	RB Bak-Chek® 3/4" Control Stop
3A.	‡	V-500-AA	1-1/2" (38 mm) Vacuum Breaker Assembly RB (Model 8152)
3B.	‡	V-500-AA	3/4" (19 mm) Vacuum Breaker Assembly RB (Model 8195)
4.	0306619	F-2-AA	1-1/2" (38 mm) Slip Joint Coupling RB (Set of Two)
5A.	‡	F-15-A	ELL with 3/4" (19 mm) Tail RB (Model 8195)
5B.		F-15-A	ELL with 1 1/2" (19 mm) Tail RB (Model 8153)
6.	0206146PK	F-21	1-1/2" (38 mm) Double Male Slip Elbow
7A.	‡	F-100	1-1/2" (38 mm) Outlet Tube RB
7B.	‡	F-102	1-1/2" (38 mm) Outlet Tube CP
8.	0306091	F-2-A	1-1/2" (38 mm) Coupling with S-21 Gasket
9A.	0306054	F-2-AW	3/4" (19 mm) Slip Joint Coupling RB
9B.	‡	F-5-A	1-1/2" (38 mm) Spud Coupling Assembly CP
10.	3325215	‡	Wall Box Frame Assembly (includes 11, 12 & 13)
11.	0334017PK	WB-18	U-Type Nuts (4)
12.	33753009	WB-1002A	Override Holder Repair Kit
13.	0318123	HY-71A	RB Hydraulic Override Button Assembly
14.	0334024PK	WB-49	1/4"-20 x 1 1/2" Tamper Resistant Screws (1 each)
15.	‡	‡	Wall Plate Assembly
16.	3334001	WB-1001-A	SS Override Button Assembly
17.	‡	‡	Diaphragm† (refer to table & diaphragm on following page)
18.	0325355	EBV-355-A	Cover Assembly (includes item 19)
19.	0325804PK	EBV-14	Coupling
19A.	0325356	EBV-356-A	Solenoid
20.	3318026	HY-1005-A	Actuator Cartridge
21.	0318195	HY-128-A1	Actuator Assembly
	—	HY-30-84	1/4" (6 mm) x 84" (2134 mm) Connecting Tubes (not shown)
	—	HY-30-24	1/4" (6 mm) x 24" (610 mm) Connecting Tubes (not shown)
22.	3325166	EBV-366AU	0.5 gpf Sensor Assembly
	3325167	EBV-367AU	1.0 gpf Sensor Assembly
	3325168	EBV-368AC	1.28 gpf Sensor Assembly
	3325169	EBV-369 AC	1.6 gpf Sensor Assembly

† Flow volume varies with valve model and desired flush volume. Refer to table and diaphragm on following page.
‡ Code and/or Part number varies with valve model variation; consult factory.

ITEM 4A. SLIP JOINT GASKETS AND RINGS

Size	Code No.	Part No.	Description
1-1/2"	5306058	F-3	Red Friction Ring
	5322001	VBF-5	Black Slip Joint Gasket
	0319086/5319086	S-30	Flexible Seat
	0319079	S-21	Rigid Seat (rubber over brass)
1-1/2" x 1-1/4"	0396062	F-105	Slip Joint Gasket – Rigid
1-1/4"	5306057	F-3	Red Friction Ring
	5322176	VBF-5	Black Slip Joint Gasket
	0307052/5307052	G-21	Rigid Seat (rubber over brass)
1"	5306056	F-3	Red Friction Ring
	5306115	F-5	Black Slip Joint Gasket
3/4"	5306055	F-3	Red Friction Ring
	5306113	F-5	Black Slip Joint Gasket

Concealed SOLIS® Flushometer



DUAL-FILTERED DIAPHRAGM ASSEMBLY

Available in diaphragm only and Royal® Performance™ Kits.

Royal® Performance™ Kit includes dual-filtered diaphragm assembly (item 3), handle repair kit with triple seal packing (item 8), high back pressure vacuum breaker repair kit (item 11), and one tailpiece O-ring (item 15A). DIAPHRAGM ONLY KIT contains “drop-in” dual-filtered diaphragm assembly (item 3) ONLY.

The dual-filtered diaphragm can be used in Royal®, Regal®, and similar diaphragm-style valve bodies. For use in Sloan valve bodies with a bell-shaped cover (manufactured before 1964), replace the bottom filter ring in these kits with a blue A-108 filter ring (not shown Sloan Code No. **5301283**).

NOTE: In January 1998, the Royal® diaphragm design was upgraded to a preassembled unit with two (2) plastic filtering rings attached to the rubber diaphragm (one on top and one on bottom). If the flushometer you are servicing has our older, segmented diaphragm with brass by-pass hole, refer to our Regal section for additional troubleshooting information.

ROYAL® HYDRAULIC PERFORMANCE KIT (Includes Dual-Filtered Diaphragm Assembly, HY83A Hydraulic Actuator Cartridge, H553 Tailpiece O-ring, and V651A High Back Pressure Vacuum Breaker Kit)

Code No.	Part No.	Description	Relief Valve†	Refill Head*	Flow Ring
3318011	HY-1101-A	Hydraulic Performance Kit Closet-1.6 gpf (6.0 Lpf)**	Green	Gray	Smooth
3318012	HY-1102-A	Hydraulic Performance Kit Closet-3.5 gpf (13.2 Lpf)**	White	Gray	Smooth
3318013	HY-1103-A	Hydraulic Performance Kit Closet-2.4 gpf (9.0 Lpf)	Blue	Gray	Smooth
3318014	HY-1106-A	Hydraulic Performance Kit Urinal-0.5 gpf (1.9 Lpf)	Green	Black	Slotted
3318015	HY-1107-A	Hydraulic Performance Kit Urinal-1.0 gpf (3.8 Lpf)**	Green	Black	Slotted
3318016	HY-1108-A	Hydraulic Performance Kit Urinal-1.5 gpf (5.7 Lpf)**	Black	Black	Smooth

*CLOSET REFILL HEADS (GRAY) HAVE LARGER SLOTS THAN URINAL REFILL HEADS (BLACK).

DIAPHRAGM ONLY KIT

Code No.	Part No.	Description	Relief Valve†	Refill Head*	Flow Ring
3301502	A-1041-A	Low Consumption Water Closets-1.6 gpf (6.0 Lpf)**	Green	Gray	Smooth
3301501	A-1038-A	Water Saver Water Closets-3.5 gpf (13.2 Lpf)**	White	Gray	Smooth
3301505	A-1044-A	9 Liter European Water Closets-2.4 gpf (9.0 Lpf)	Blue	Gray	Smooth
3301504	A-1043-A	Wash Down Urinals-0.5 gpf (1.9 Lpf)	Green	Black	Slotted
3301503	A-1042-A	Low Consumption Urinals-1.0 gpf (3.8 Lpf)**	Green	Black	Slotted
3301500	A-1037-A	Water Saver Urinals-1.5 gpf (5.7 Lpf)**	Black	Black	Smooth
3301506	A-1045-A	High-Efficiency Water Closets-1.28 gpf (4.8 Lpf)	Blue	Gray	Smooth
3301142	A-1047-A	High-Efficiency Urinals-0.25 gpf (1.0 Lpf) with White Inserts	White	HEU Black	Smooth
3301143	A-1050-A	High-Efficiency Urinals-0.125 gpf (0.5 Lpf) with White Inserts	Blue	HEU Black	Smooth
3301594	A-1075-A-BX	High-Efficiency Water Closets-1.28 gpf (4.8 Lpf) RW	Blue	Black	Smooth
3301592	A-1073-A-BX	High-Efficiency Urinals-0.5 gpf (1.9 Lpf) RW	Green	Black	Slotted
3301591	A-1077-A-BX	High-Efficiency Urinals-0.25 gpf (1.0 Lpf) RW	White	HEU Black	Smooth
3301590	A-1070-A-BX	High-Efficiency Urinals-0.125 gpf (0.5 Lpf) RW	Blue	HEU Black	Smooth

† Consult factory for availability of replacement plastic relief valves (green, black, blue, and white) and brass relief valves.

NOTE: For older water closets that require 4.5 gpf (17.0 Lpf), choose kits A-1102-A or A-1038-A, but remove the flow ring before use. For blowout-style urinals that require 3.5 gpf (13.2 Lpf), choose kits A-1102-A or A-1038-A. For service sinks that require 6.5 gpf (24.6 Lpf), order A-36-A diaphragm repair kit (not shown Sloan Code No. **3301036**) and remove the flow ring before use. Regulations for low consumption fixtures prohibit the use of higher flush volumes.

*CLOSET REFILL HEADS (GRAY) HAVE LARGER SLOTS THAN URINAL REFILL HEADS (BLACK).

** WATER SAVER (3.5 GPF CLOSET AND 1.5 GPF URINAL) AND LOW CONSUMPTION (1.6 GPF CLOSET AND 1.0 GPF URINAL) FIXTURES MUST USE MATCHING GPF (LPF) DIAPHRAGM KITS; USING A SMALLER GPF (LPF) KIT IN FIXTURES NOT INTENDED FOR LESS VOLUME WILL RESULT IN INADEQUATE DILUTION IN URINALS AND IMPROPER EVACUATION IN CLOSETS. RW for use with Reclaimed Water Flushometers.

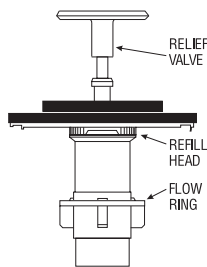

THE COLORS OF THE RELIEF VALVE AND THE REFILL HEAD PLUS THE SHAPE OF FLOW RING IDENTIFY THE FLUSH VOLUME OF A DUAL-FILTERED DIAPHRAGM ASSEMBLY.

Concealed SOLIS® Flushometer

TROUBLESHOOTING GUIDE

NOTE: Upon detection of the user, the red indicator light flashes slowly, during start-up (first 10 minutes). After a period of eight seconds unit is ready to flush. When the user leaves the detection range, the sensor initiates the flush sequence. Then the indicator light stops flashing and the valve flushes. The valve will flush after a three-second (water closets) or one-second (urinals) delay.

1. Sensor flashes continuously only when user steps within range.

- A. Unit in start-up mode; no problem. This feature is active for the first ten (10) minutes of operation.

2. Valve DOES NOT flush; sensor does not picking up user.

- A. Range too short; increase the range. Consult factory.

3. Valve DOES NOT flush; sensor picking up opposite wall or surface, or only flushes when someone walks by. Light flashes continuously for first 10 minutes even with no one in front of the sensor.

- A. Range too long; shorten range. Consult factory.

4. Valve DOES NOT flush even after adjustment.

- A. Batteries completely used up; replace batteries.
- B. Problem with electronic sensor module; replace electronic sensor module.
- C. Problem with solenoid; replace solenoid.

5. Unit flashes a sequence of 4 quick times when user steps within range.

- A. Batteries low; replace batteries.

6. Valve DOES NOT shut off.

- A. Bypass orifice in diaphragm is clogged with dirt or debris, or bypass is clogged by an invisible gelatinous film due to "over-treated" water. Remove diaphragm and wash under running water. **NOTE:** Size of orifice in the bypass is of utmost importance for the proper metering of water by the valve. **DO NOT ENLARGE OR DAMAGE THIS ORIFICE.** Replace diaphragm if cleaning does not correct the problem.
- B. Dirt or debris fouling relief valve or diaphragm. Remove diaphragm and wash under running water.
- C. Problem with electronic sensor module; replace sensor module.

7. Not enough water to fixture.

- A. Wrong relief valve installed in diaphragm kit. Install the correct relief valve.
- B. Wrong SOLIS® model installed; i.e., 1.0 gpf urinal installed on 3.5 gpf closet fixture. Replace with proper SOLIS model.
- C. Enlarged bypass in diaphragm. Replace diaphragm.
- D. Control stop not adjusted properly. Readjust control stop.
- E. Inadequate volume or pressure at supply. Increase water pressure or supply (flow) to valve. Consult factory for assistance.

8. Too much water to fixture.

- A. Wrong relief valve installed in diaphragm kit. Install the correct relief valve.
- B. Control stop not adjusted properly. Readjust control stop.
- C. Wrong SOLIS model installed; i.e., 1.6 gpf model installed on 1.0 or 1.5 gpf urinal fixture. Replace with proper SOLIS model.
- D. Dirt in diaphragm bypass. Clean under running water or replace diaphragm.

PUSH BUTTON ACTUATOR

9. Leakage occurring at the push button.

- A. Damage or worn seals or lime build-up in the actuator cartridge. Replace with new cartridge.

10. The flushometer DOES NOT flush and a small amount of leakage is visible below the valve.

- A. Foreign material lodged in the cartridge. Remove the cartridge and inspect for foreign material. Clean under running water.
- B. Damaged or worn seals or lime build-up in the actuator cartridge. Replace with new cartridge.
- C. Plastic tubing installed incorrectly. Match tubing ends from valve body actuator to button actuator, so that "L" to "L" and "O" to "O".

FLUSHOMETER ACTUATOR ASSEMBLY

11. The flushometer DOES NOT flush or flushes only once and will not flush a second time when the button is pushed.

- A. The plunger is lodged in the actuator cartridge or the plunger bypass hole is clogged. Remove the actuator housing & cartridge from the flushometer. Clean under running water. If cartridge parts are worn, deteriorated or limed up & problem persists after cleaning, replace with new cartridge.
- B. Plastic tubing installed incorrectly. Match tubing ends from valve body actuator to button actuator, so that "L" to "L" and "O" to "O".

TO REMOVE THE ACTUATOR FROM THE FLUSHOMETER

- A. Turn off water from control stop.
- B. Unscrew the housing coupling nut from the flushometer.
- C. Remove the actuator housing from the flushometer. The tubing connections can be left intact.
- D. Remove the actuator cartridge from the flushometer body. Care should be taken so that upon removal the actuator and the o-ring do not separate due to spring compression within. If the actuator cartridge is lodged in the body cavity, grip the exposed portion gently with a pair of channel-lock pliers and rotate back and forth to loosen the o-ring seal.
- E. Separate the actuator housing to reveal the spring and plunger.

!!! IMPORTANT — CONTROL STOP SETTING !!!

NEVER OPEN CONTROL STOP TO WHERE THE FLOW FROM THE VALVE EXCEEDS THE FLOW CAPABILITY OF THE FIXTURE. IN THE EVENT OF A VALVE FAILURE, THE FIXTURE MUST BE ABLE TO ACCOMMODATE A CONTINUOUS FLOW FROM THE VALVE.

THIS PRODUCT CONTAINS MECHANICAL AND/OR ELECTRICAL COMPONENTS THAT ARE SUBJECT TO NORMAL WEAR. THESE COMPONENTS SHOULD BE CHECKED ON A REGULAR BASIS AND REPLACED AS NEEDED TO MAINTAIN THE VALVE'S PERFORMANCE.

LAWS AND REGULATIONS PROHIBIT THE USE OF HIGHER FLUSHING VOLUMES THAN LISTED ON FIXTURE OR FLUSHOMETER.

DO NOT USE TOOTHED TOOLS TO INSTALL OR SERVICE THESE VALVES. USE A SLOAN A-50 SUPER WRENCH, SLOAN A-109 PLIER WRENCH OR SMOOTH JAWED WRENCH TO SECURE ALL COUPLINGS.

CARE AND CLEANING INSTRUCTIONS

DO NOT USE abrasive or chemical cleaners to clean flushometers that may dull the luster and attack the finish. Use **ONLY** mild soap and water, then wipe dry with a clean towel or cloth. When cleaning the bathroom tile, protect the flushometer from any splattering of cleaner. Acids and cleaning fluids can discolor or remove finish.

**When assistance is required, please contact
Sloan Technical Support at: 1-888-SLOAN-14 (1-888-756-2614).**

Control Stop



CONTROL STOP AND REPLACEMENT PARTS

H-700 Series Bak-Chek® control stops and replacement parts (available for 3/4" and 1" water supply inlet pipes)
Replaces H-600 and H-540 Series control stops

Code No. Part No. Description

H-700 Stop, chrome plated: Screwdriver Angle Stop with H-1010-A Vandal Resistant Cap

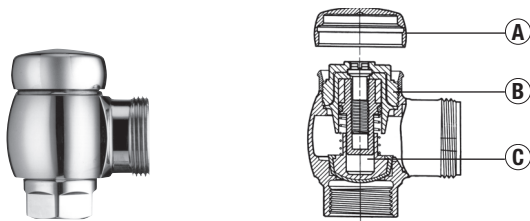

Complete Stops

3308384	H-700-A	3/4" NPTF inlet for adjustable tail
3308386	H-700-A	1" NPTF inlet for adjustable tail
3308385	H-700-AG	3/4" NPTF inlet for ground joint tail
3308387	H-700-AG	1" NPTF inlet for ground joint tail
3308388	H-700-AW	1" Whitworth inlet for adjustable tail

Repair Parts

3308772	H-1010-A	A Vandal Resistant Cap*, chrome plated
0308612	H-622	B Bonnet, chrome plated
3308853	H-541-ASD	C Control Stop Repair Kit*

H-710 Stop, chrome plated: Screwdriver Angle Stop with H-573-A Locking Vandal Resistant Cap

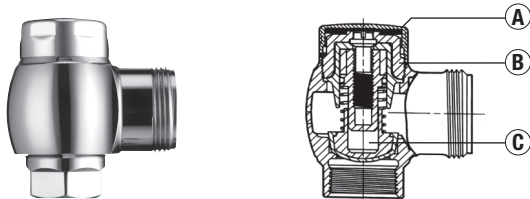

Complete Stops

0388025	H-710-A	3/4" NPTF inlet for adjustable tail
0388022	H-710-A	1" NPTF inlet for adjustable tail
0388026	H-710-AG	3/4" NPTF inlet for ground joint tail
0388024	H-710-AG	1" NPTF inlet for ground joint tail
0388037	H-710-AW	1" Whitworth inlet for adjustable tail
0388062	H-710-AAR	1" BSP British Standard Pipe inlet for adjustable tail
0388043	NH-710-A	1" NPTF inlet for adjustable tail (Naval brass)
0388048	NH-710-AG	3/4" NPTF inlet for ground joint tail (Naval brass)
0388058	NH-710-AG	1" NPTF inlet for ground joint tail (Naval brass)
0388042	NH-710-AW	1" Whitworth inlet for adjustable tail (Naval brass)
0388045	NH-710-AGW	1" Whitworth inlet for ground joint tail (Naval brass)
0388044	NH-710-AGS	1" NPSM inlet for ground joint tail (Naval brass)

Repair Parts

3308840	H-573-A	A Locking Vandal Resistant Cap*, chrome plated
0308612	H-622	B Bonnet, chrome plated
3308853	H-541-ASD	C Control Stop Repair Kit*

H-720 Stop, chrome plated: Screwdriver Angle Stop with H-574 Short bumper Cap (-YO Variation)

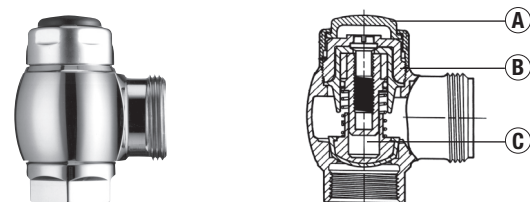

Complete Stops

0388034	H-720-A	1" NPTF inlet for adjustable tail
0388033	H-720-AG	1" NPTF inlet for ground joint tail
0388038	H-720-AW	1" Whitworth inlet for adjustable tail

Repair Parts

3308866	H-574	A Stop Cap with Seat Bumper*, chrome plated
0308612	H-622	B Bonnet, chrome plated
3308853	H-541-ASD	C Control Stop Repair Kit*

Control Stop

CONTROL STOP AND REPLACEMENT PARTS

H-725 Stop, chrome plated: Screwdriver Angle Stop with H-576 Extended Bumper Cap (-YG Variation)

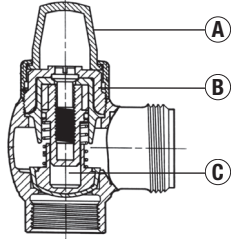

Complete Stops

0388035	H-725-A	1" NPTF inlet for adjustable tail
0388057	H-725-AG	1" NPTF inlet for ground joint tail
0388039	H-725-AW	1" Whitworth inlet for adjustable tail
0388047	NH-725-AGW	1" Whitworth inlet for ground joint tail (Naval brass)

Repair Parts

3308867	H-576	A Stop Cap with Extended Seat Bumper chrome plated
0308612	H-622	B Bonnet, chrome plated
3308853	H-541-ASD	C Control Stop Repair Kit*

H-730 Stop, rough brass: Concealed Wheel Handle Angle Stop

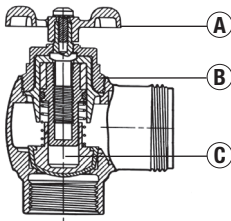

Complete Stops

0388011	H-730-A	3/4" NPTF inlet for adjustable tail
0388010	H-730-A	1" NPTF inlet for adjustable tail
0388014	H-730-AG	3/4" NPTF inlet for ground joint tail
0388013	H-730-AG	1" NPTF inlet for ground joint tail
0388012	H-730-AW	1" Whitworth inlet for adjustable tail
0388056	NH-730-AG	3/4" NPTF inlet for ground joint tail (Naval brass)
0388017	NH-730-AG	1" NPTF inlet for ground joint tail (Naval brass)
0388041	NH-730-AW	1" Whitworth inlet for adjustable tail (Naval brass)
0388046	NH-730-AGW	1" Whitworth inlet for ground joint tail (Naval brass)

Repair Parts

3308872	H-1011-A	A Concealed Wheel Handle Repair Kit*
0208083	H-623	B Bonnet, rough brass
3308860	H-1006-A	C Control Stop Repair Kit*

H-735 Stop, chrome plated: Exposed Wheel Handle Angle Stop

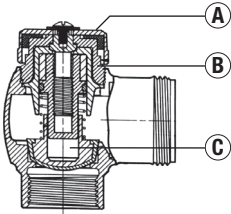

Complete Stops

0388007	H-735-A	3/4" NPTF inlet for adjustable tail
0388006	H-735-A	1" NPTF inlet for adjustable tail
0388009	H-735-AG	3/4" NPTF inlet for ground joint tail
0388008	H-735-AG	1" NPTF inlet for ground joint tail

Repair Parts

3308060	H-1002-A	A Exposed Wheel Handle Repair Kit*
0308615	H-623	B Bonnet, chrome plated
3308855	H-541-AWH	C Control Stop Repair Kit*

Control Stop

CONTROL STOP AND REPLACEMENT PARTS

H-740 Stop, chrome plated: Screwdriver Angle Stop with H-37 Cap (Regal® Valve Stop) – DISCONTINUED
H-790 Stop, chrome plated: Screwdriver Angle Stop with Vandal Resistant Cap (for Regal or Regal XL Valve Stop)

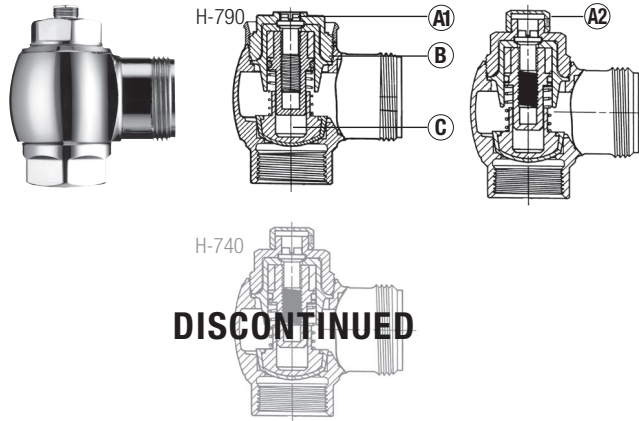

Code No.	Part No.	Description
----------	----------	-------------

Complete Stops For Regal® flushometers

0388031	H-740-A	3/4" NPTF inlet for adjustable tail – DISCONTINUED
0388029	H-740-A	1" NPTF inlet for adjustable tail – DISCONTINUED
0388040	H-740-AG	3/4" NPTF inlet for ground joint tail – DISCONTINUED
0388028	H-740-AG	1" NPTF inlet for ground joint tail – DISCONTINUED

Complete Stops For Regal® "XL" flushometers

0388064	H-790-A	3/4" NPTF inlet for adjustable tail
0388065	H-790-A	1" NPTF inlet for adjustable tail
0388068	H-790-AG	3/4" NPTF inlet for ground joint tail
0388067	H-790-AG	1" NPTF inlet for ground joint tail

Repair Parts

5388002	H-528	Ⓐ Hole Plug
5388001	H-1012-A	Ⓐ Vandal Resistant Socket Cap*, chrome plated with set screw, for Regal "XL" flushometer – 6 per package
0308612	H-622	Ⓑ Bonnet, chrome plated
3308853	H-541-ASD	Ⓒ Control Stop Repair Kit*

H-745 Stop, chrome plated: Screwdriver Angle Stop with J-2/J-7 Bumper (for Regal® Valve Stop) (-Y0/-YG Variations) – DISCONTINUED

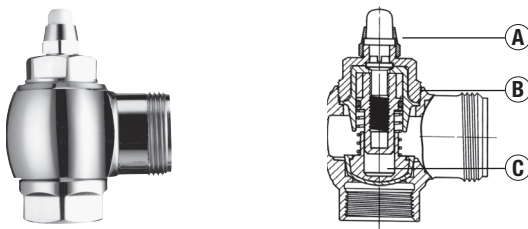

Complete Stops

0388035	H-725-A	1" NPTF inlet for adjustable tail
---------	---------	-----------------------------------

Repair Parts

5310034	J-2/J-7	Ⓐ Cap*, chrome plated – 6 per package DISCONTINUED
0308991	H-639	Ⓑ Bonnet, chrome plated – DISCONTINUED
3308853	H-541-ASD	Ⓒ Control Stop Repair Kit* – DISCONTINUED

H-750 Stop, chrome plated: Screwdriver Straight Stop with H-1010-A Vandal Resistant Cap

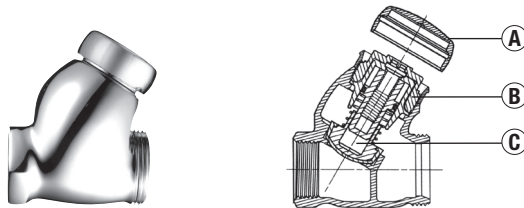

Complete Stops

3308389	H-750-AG	1" NPTF inlet for ground joint tail
---------	----------	-------------------------------------

Repair Parts

3308772	H-1010-A	Ⓐ Vandal Resistant Cap*, chrome plated
0308612	H-622	Ⓑ Bonnet, chrome plated
3308853	H-541-ASD	Ⓒ Control Stop Repair Kit*

H-760 Stop, chrome plated: Screwdriver Straight Stop with H-573-A Locking Vandal Resistant Cap

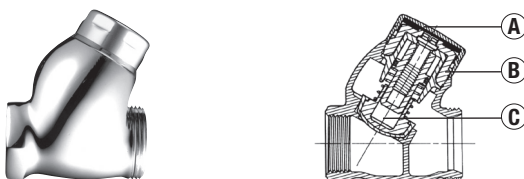

Complete Stops

0388023	H-760-AG	1" NPTF inlet for ground joint tail
---------	----------	-------------------------------------

Repair Parts

0308738	H-573-A	Ⓐ Locking Vandal Resistant Cap*, chrome plated
0308612	H-622	Ⓑ Bonnet, chrome plated
3308853	H-541-ASD	Ⓒ Control Stop Repair Kit*

Control Stop

CONTROL STOP AND REPLACEMENT PARTS

H-770 Stop, rough brass: Concealed Wheel Handle Straight Stop

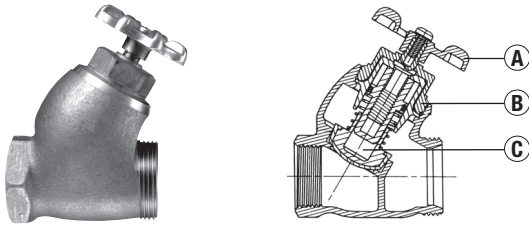

Complete Stops

0388030 H-770-AG 1" NPTF inlet for ground joint tail

Repair Parts

3308872 H-1011-A **A** Concealed Wheel Handle Repair Kit*

0208083 H-623 **B** Bonnet, rough brass

3308860 H-1006-A **C** Control Stop Repair Kit*

H-775 Stop, chrome plated: Exposed Wheel Handle Straight Stop

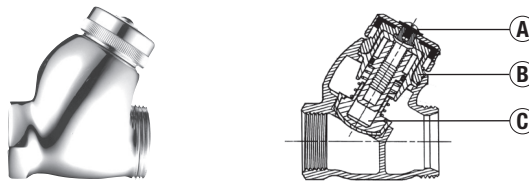

Complete Stops

0388036 H-775-AG 1" NPTF inlet for ground joint tail

Repair Parts

3308060 H-1002-A **A** Exposed Wheel Handle Repair Kit*

0308615 H-623 **B** Bonnet, chrome plated

3308855 H-541-AWH **C** Control Stop Repair Kit*

H-780 Stop, chrome plated: Screwdriver Straight Stop with H-37 Cap (Regal® Valve Stop) and H-795 Stop, chrome plated: Screwdriver Straight Stop with Vandal Resistant Cap (for Regal or Regal XL Valve Stop)

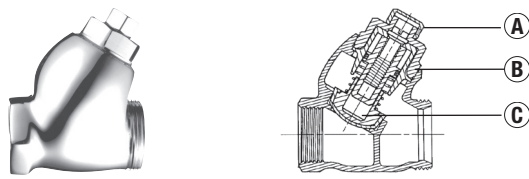

Complete Stops For Regal® flushometers

0388027 H-780-AG 1" NPTF inlet for ground joint tail – **DISCONTINUED**

Complete Stops For Regal® "XL" flushometers

0388079 H-795-AG 1" NPTF inlet for ground joint tail

Repair Parts

5388001 H-1012-A **A** Vandal Resistant Socket Cap*, chrome plated with set screw, for Regal "XL" flushometer – 6 per package

0308991 H-639 **B** Bonnet, chrome plated

3308853 H-541-ASD **C** Control Stop Repair Kit*

For H-790 Stop, refer to information shown for H-740 and H-790 Stops
For H-795 Stop, refer to information shown for H-780 and H-795 Stops

CONTROL STOP AND REPLACEMENT PARTS FOR H-540, H-600 AND H-700 SERIES CONTROL STOPS

Replacement Stop Caps for Screwdriver Control Stops for H-540, H-600, and H-700 Series Control Stops

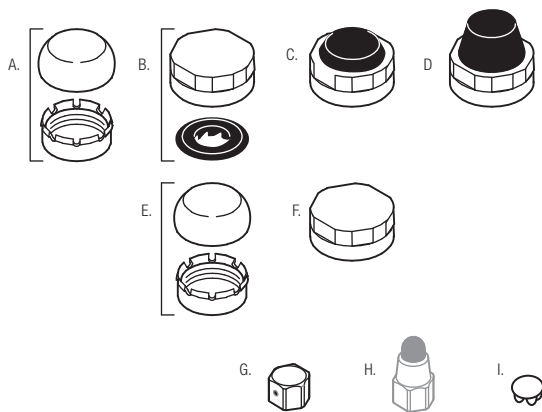

For 1" H-600 and H-700 Series Stops and 3/4" H-700 Series Stops

Item No.	Code No.	Part No.	Description
A.	3308772	H-1010-A	Vandal Resistant Stop Cap, chrome plated, with Sleeve
	5308954	H-628	Plastic Sleeve only – 6 per package
B.	3308840	H-573-A	Locking Vandal Resistant Stop Cap, chrome plated
C.	3308866	H-574	Stop Cap, chrome plated with Seat Bumper (-YO)
D.	3308867	H-576	Stop Cap, chrome plated with Extended Seat Bumper (-YG)

For 3/4" H-600 Series Stops

E.	3308790	H-1009-A	Vandal Resistant Stop Cap, chrome plated, with Sleeve and 3/4" Bonnet
	5308952	H-614	Plastic Sleeve only – 6 per package
F.	0308848	H-582	Stop Cap, chrome plated

For all H-40, H-440, H-540 and H-740 Series Stops

G.	5388001	H-1012-A	Vandal Resistant Stop Cap with set screw, chrome plated – 6 per package
H.	5310034	J-2/J-7	Stop Cap, chrome plated with Seat Bumper – 6 per package – DISCONTINUED
I.	5388002	H-528	Hole Plug

Control Stop

CONTROL STOP AND REPLACEMENT PARTS FOR H-540, H-600 AND H-700 SERIES CONTROL STOPS

Screwdriver Control Stop Repair Kits

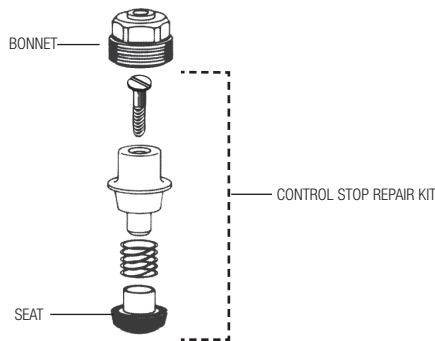

Code No.	Part No.	Description
----------	----------	-------------

Complete Repair Kits

3308853	H-541-ASD	For 1" H-540, H-600 and H-700 Series Stops and 3/4" H-700 Series Stops
3308856	H-543-ASD	For 3/4" H-540 and H-600 Series Stops

Bonnets

0308612	H-622	For 1" H-600 and H-700 Series Stops and 3/4" H-700 Series Stops
0308991	H-639	For 1" H-540 and H-740 Series Stops and 3/4" H-740 Series Stops
0308843	H-577	For 3/4" H-600 Series Stops – DISCONTINUED
0308601	H-538	For 3/4" H-540 Series Stops – DISCONTINUED

Seat only – 6 per package

5308850	H-584	For 1" H-540, H-600 and H-700 Series Stops and 3/4" H-700 Series Stops
5308836	H-569	For 3/4" H-540 and H-600 Series Stops

Concealed Wheel Handle Control Stop Repair Kits – Note: Repair Kit includes H-1011-A Wheel Handle Repair Kit

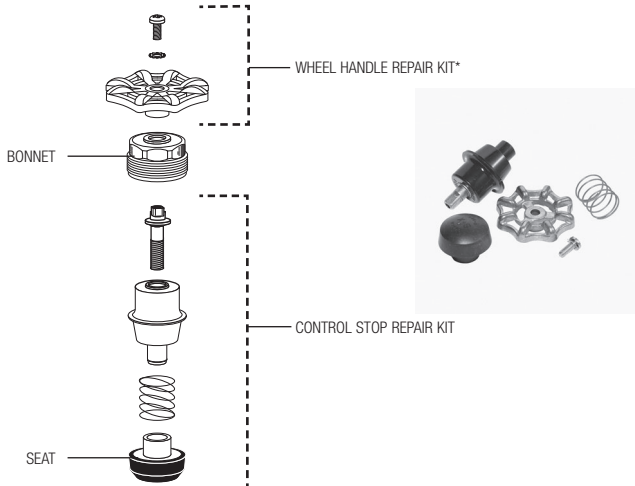

Complete Repair Kits

3308860	H-1006-A	For 1" H-540, H-600 and H-700 WH Series Stops and 3/4" H-700 WH Series Stops
3308859	H-1007-A	For 3/4" H-540 and H-600 Series Stops

Wheel Handle Repair Kit — Note: Repair Kit includes handle, screw and lockwasher

3308872	H-1011-A	For all Concealed Wheel Handle Stops
----------------	----------	--------------------------------------

Bonnets

0208083	H-623	For 1" H-540, H-600 and H-700 WH Series Stops and 3/4" H-700 Series Stops
0308705	H-561	For 3/4" H-540, H-600 Series Stops – DISCONTINUED

Seat only – 6 per package

5308850	H-584	For 1" H-540, H-600 and H-700 WH Series Stops and 3/4" H-700 WH Series Stops
5308836	H-569	For 3/4" H-540 and H-600 Series Stops

NOTE: H-540 and H-600 Series concealed wheel handle stops made prior to 1993 featured a design identical to the exposed wheel handle design. These stops can be repaired using an exposed wheel handle repair kit or converted to the current design by using a concealed wheel handle repair kit.

Exposed Wheel Handle Control Stop Repair Kits

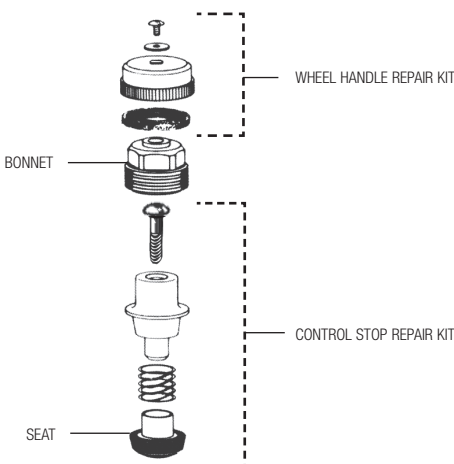

Complete Repair Kits

3308855	H-541-AWH	For 1" H-540, H-600 and H-700 WH Series Stops and 3/4" H-700 Series Stops
3308858	H-543-AWH	For 3/4" H-540 and H-600 Series Stops

Wheel Handle Repair Kit — Note: Repair Kit includes handle, washer, screw and lockwasher

3308060	H-1002-A	For all Exposed Wheel Handle Stops
5308059	H-1003-A	Screw and Lockwasher only – 12 per package

Bonnets

0308615	H-623	For 1" H-540, H-600 and H-700 WH Series Stops and 3/4" H-700 Series Stops
0308705	H-561	For 3/4" H-540 and H-600 Series Stops DISCONTINUED









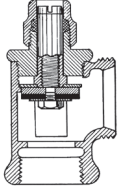

Seat only – 6 per package

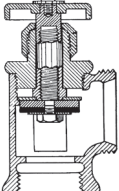
5308850	H-584	For 1" H-540, H-600 and H-700 WH Series Stops and 3/4" H-700 WH Series Stops
5308836	H-569	For 3/4" H-540 and H-600 Series Stops

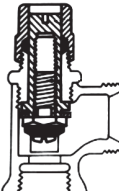
NOTE: 1" and 3/4" H-700 Series stops use "common stop" repair kits. 1" and 3/4" H-540 and H-600 Series stops use stop repair kits unique to each size. See the "common stop" on page 102 for more details.

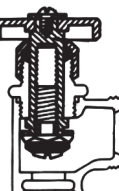
Control Stop

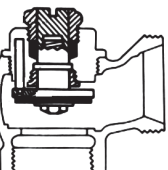
CONTROL STOP AND REPLACEMENT PARTS FOR OLDER CONTROL STOPS

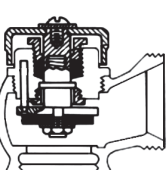
		Code No.	Part No.	Description
H-10-A 1" Screwdriver Angle Stop, (also fits H-15-A 1" Screwdriver Straight Stop) — used from 1920's through 1940's				
		5308077	H-12	Packing only – 12 per package
		—	—	Bonnet no longer available
H-10-A 1" Wheel Handle Angle Stop (also fits H-15-A 1" Wheel Handle Straight Stop) — Used from 1920's through 1940's				
		5308077	H-12	Packing only – 12 per package
		—	—	Bonnet no longer available
H-20-A 1/2" and 3/4" Screwdriver Angle Stop (also fits H-30-A Screwdriver Straight Stop) — Used from 1920's through 1950's				
		5308077	H-12	Packing only – 12 per package
		—	—	Bonnet no longer available
H-20-A 1/2" and 3/4" Wheel Handle Angle Stop (also fits H-30-A Wheel Handle Straight Stop) — Used from 1920's through 1950's				
		5308077	H-12	Packing only – 12 per package
		—	—	Bonnet no longer available
H-40-A 3/4" and 1" Screwdriver Angle Stop (also fits H-45-A Screwdriver Straight Stop) — Used from 1930's through 1960's				
		3308277	H-47-A-SD	Repair kit includes packing ring, key socket, lock shield, retaining ring, screw assembly, and packing
		0308176	H-39-A-SD	Bonnet assembly repair kit includes a bonnet assembled with packing ring, key socket, retaining ring, screw assembly, and packing plus our H-37 Vandal Resistant Stop Cap that replaces the lock shield
		5308077	H-12	Packing only – 12 per package
		0308167	H-39	Bonnet Only
H-40-A 3/4" and 1" Wheel Handle Angle Stop (also fits H-45-A Wheel Handle Straight Stop) — Used from 1930's through 1960's				
		3308278	H-47-A-WH	Repair kit includes packing ring, screw, wheel handle, key stem, gland for wheel handle, retaining gland, screw assembly, washer and packing
		0308175	H-39-A-WH	Bonnet assembly repair kit includes a bonnet assembled with packing ring, screw, wheel handle, key stem, gland for wheel handle, retaining gland, screw assembly, washer and packing
		5308077	H-12	Packing only – 12 per package
		0308170	H-39	Bonnet Only

NOTE: STOPS PRIOR TO 1964 WERE GROUND JOINT

Control Stop

CONTROL STOP AND REPLACEMENT PARTS

Code No.	Part No.	Description
----------	----------	-------------

H-340-A 3/4" and 1" Screwdriver and Wheel Handle Angle Stops — Used from 1940's through 1950's

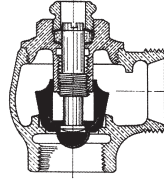

The only replacement part available for this stop is the rubber plug.

0308433	H-382-A	Rubber Plug
----------------	---------	-------------

H-440-A 3/4" Screwdriver Angle Stop — Used from 1950's through 1960's

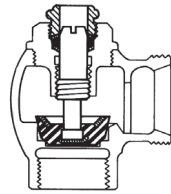

3308442	H-484-A-SD	Repair kit includes lock shield, packing, key stem, rubber plug, and packing ring
----------------	------------	---

0308432	H-439-AU	Bonnet assembly repair kit includes a bonnet assembled with packing, key stem, rubber plug, and packing ring plus our H-37 Vandal Resistant Stop Cap that replaces the lock shield
----------------	----------	--

0308434	H-439	Bonnet
----------------	-------	--------

0308490	H-484-A	Rubber Plug
----------------	---------	-------------

5308077	H-12	Packing only – 12 per package
----------------	------	-------------------------------

H-440-A 3/4" Wheel Handle Angle Stop — Used from 1950's through 1960's

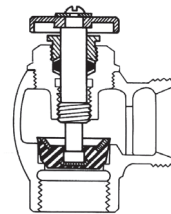

0308435	H-439	Bonnet
----------------	-------	--------

0308490	H-484-A	Rubber Plug
----------------	---------	-------------

5308077	H-12	Packing only – 12 per package
----------------	------	-------------------------------

H-440-A 1" Screwdriver Angle Stop (also fits H-445-A Screwdriver Straight Stop) — Used from 1950's through 1960's

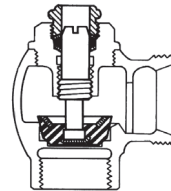

3308453	H-482-A-SD	Repair kit includes lock shield, packing, key stem, rubber plug, and packing ring
----------------	------------	---

0308428	H-439-A	Bonnet assembly repair kit includes a bonnet assembled with packing ring, key socket, retaining ring, screw assembly, and packing plus our H-37 Vandal Resistant Stop Cap that replaces the lock shield
----------------	---------	---

0308434	H-439	Bonnet
----------------	-------	--------

0308489	H-482-A	Rubber Plug
----------------	---------	-------------

5308077	H-12	Packing only – 12 per package
----------------	------	-------------------------------

H-440-A 1" Wheel Handle Angle Stop (also fits H-445-A Wheel Handle Straight Stop) — Used from 1950's through 1960's

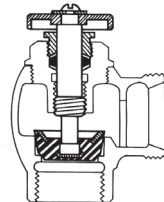

0308435	H-439	Bonnet
----------------	-------	--------

0308489	H-482-A	Rubber Plug
----------------	---------	-------------

5308077	H-12	Packing only – 12 per package
----------------	------	-------------------------------

NOTE: H-440 Series control stops were used with Sloan's "Quiet Flush" flushometer models.

NOTE: All obsolete control stops are for ground joint tailpiece connections.

NOTE: Sloan has made other stops up to 1964. If you have an older stop that is not listed on these two pages, the repair parts are obsolete. Prior to 1964, all stops were ground joint connections; the H-700-AG series stops, 3/4" and 1" angle stops, and 1" straight stops, are the current replacement.

Control Stop

THE "COMMON STOP"

In 1996, Sloan began using the H-700 series of control stops with all flushometers. This "common stop" offers 3/4" and 1" supply inlet size options, yet uses a single repair kit for both urinal and water closet stops. This change primarily affects the H-700 series 3/4" stops, which now use the same repair kit as 1" stops. Repair kits for the smaller H-540 and H-600 3/4" stops remain available and are included in this section.

The "common stop" body offers precise control over flow rates delivered through the valve. This feature is important, especially for 1-gallon urinal designs. This finite flow adjustment makes the difference between a proper flush and an ineffective flush that splashes and spills.

The "common stop" internal components are interchangeable with their counterparts in older H-600 and H-540 stops. The distinctively contoured seat plug in the "common stop" allows a finer flow rate adjustment similar to that of a needle valve. Unlike natural rubber components that can be destroyed by water treatment products, our synthetic Permex™ rubber seat plugs resist the effects of chloramines. Our stop spring, formerly brass, is now constructed of stainless steel. This helps prevent corrosion from the increasingly aggressive water supplies we see today.

All complete "common stops" now have bonnets stamped with an H-700 series number. Both exposed and concealed wheel handle stops are stamped H-700-WH series. The H-740 and H-780 stops that replace the H-540 series stops used with Regal valves are stamped H-740 series.

CONTROL STOP DESIGNS

Supply Inlets

Sloan supplies control stops in two basic inlet sizes:

1. 3/4" NPTF — For most urinal flushometers
2. 1" NPTF — For all water closet flushometers and blow-out urinal flushometers

Control stops are also available in some models with the following inlets for specialized and export applications:

1. 1" Whitworth thread
2. 1" BSP British Standard Pipe inlet
3. 1" NSPM Straight thread — for use with shipboard Sil-Braz fittings

Tailpiece Connections

The majority of flushometers supplied by Sloan since 1964 feature an adjustable tailpiece. Connection of the valve tailpiece to the control stop is made with a sliding O-ring seal.

Older valves (produced before 1964), and valves furnished for salt-water installations, and all straight stops utilized a metal-to-metal ground joint (G.J) connection.

When replacing an older stop, it is important to note which type of stop connection is required.

Stops for use with salt water must be made from Naval brass.

GENERAL INSTALLATION INSTRUCTIONS

Install the Sloan Bak-Chek® control stop to water supply line with outlet positioned as required. Tighten the control stop coupling with a wrench.

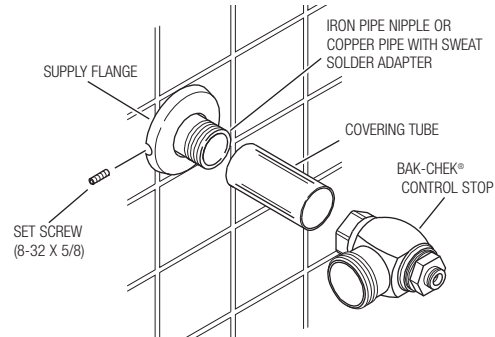

CONTROL STOP ADJUSTMENT

After installation or service, readjust the control stop to meet the flow rate required for the proper cleansing of the fixture. Open the control stop COUNTERCLOCKWISE one full turn from the closed position. Activate flushometer.

Adjust control stop after each flush until the rate of flow delivered properly cleanses the fixture. Turn the control stop adjustment screw (or wheel handle) COUNTERCLOCKWISE to increase the flow rate or CLOCKWISE to decrease the flow rate.

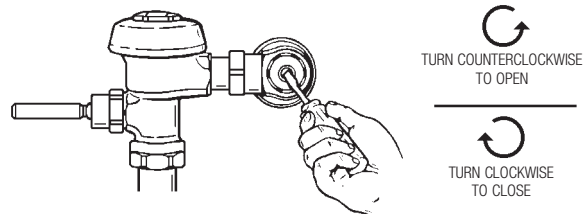

Important: A Sloan flushometer is engineered for quiet operation. Excessive water flow creates noise, while too little water flow may not satisfy the needs of the fixture. Proper adjustment is made when the plumbing fixture is cleansed after each flush without splashing water out from the lip AND a quiet flushing cycle is achieved.

The control stop should never be opened to the point where the flow from the valve exceeds the flow capability of the fixture. In the event of a valve failure, the fixture must be able to accommodate a continuous flow from the valve.

MAINTENANCE AND CLEANING

Control stops have moving parts that may wear over time. Deterioration of rubber parts may result in an incomplete seal. If you can not shut off the stop completely, or if leakage is visible at the adjustment screw, order one of our control stop repair kits and rebuild the control stop.

DO NOT USE abrasive or chemical cleaners to clean flushometers. These cleaners may dull the luster and attack the chrome or special decorative finishes. Use **ONLY** mild soap and water, and then wipe dry with a clean cloth or towel. While cleaning the bathroom tile, protect the flushometer from any splattering of cleaner. Acids and cleaning fluids can discolor or remove chrome plating.

Tailpiece

TAILPIECES



The tailpiece is the connection between the valve body and the control stop. Sloan adjustable and ground joint tailpieces are threaded into the valve body at the factory. Sloan tailpieces are available in a variety of lengths to accommodate installation rough-in errors and unique installation requirements.

Sloan flushometer brands feature three types of tailpiece connections:



H-551 ADJUSTABLE TAILPIECE



H-5 GROUND JOINT TAILPIECE



H-130-A ADJUSTABLE GROUND JOINT TAILPIECE

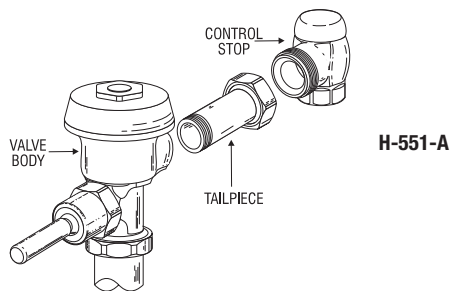

H-551-A

TAILPIECE REPLACEMENT

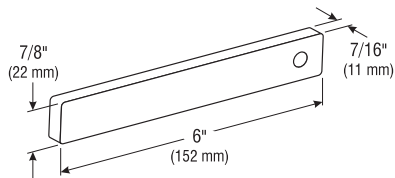

H-530 TAILPIECE REMOVAL BAR
0334014

Sloan adjustable and ground joint tailpieces are assembled into the valve body using a pipe thread. Significant force is used to drive the tailpiece into the valve body. As such, removal of the old tailpiece may be difficult.

For replacement, we recommend using the **H-530 tailpiece removal bar** (Code No. **0334014**). Remove the flushometer cover and interior parts. Secure the tailpiece removal bar vertically in a vice. Place the flushometer tailpiece over the bar. The cast lugs inside the tailpiece will catch on the bar. Insert a length of 3/4" pipe into the barrel of the valve body. Unscrew tailpiece from valve body.

Assemble the new tailpiece into the valve body in the reverse manner. Use teflon tape (or pipe sealant) on tailpiece pipe threads. Ensure that both the coupling and the locking ring (adjustable tailpiece only) are on the tailpiece before tightening the assembly. Do NOT use sealant on the first few threads of the tailpiece.

H-551-A ADJUSTABLE TAILPIECE CONNECTION

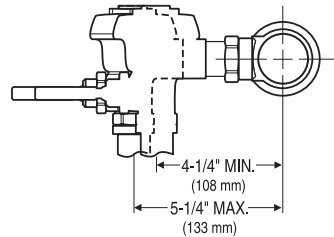

The majority of flushometers supplied by Sloan since 1964 feature the H-551-A adjustable tailpiece. The valve tailpiece connects to the control stop with a sliding O-ring seal. The H-551-A adjustable tailpiece standard length is 2-1/16" (54 mm). This is designed for a standard flushometer installation in which the distance between the centerline of the valve and the centerline of the water supply inlet is 4-3/4" (121 mm). The adjustable tailpiece allows for a variance of ±1/2" (13 mm) from this nominal dimension.

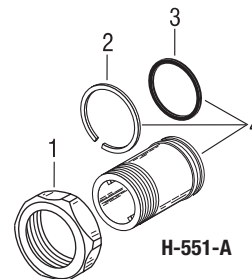

H-551-A

Item

Item No.	Code No.	Part No.	Description
1.	0308676	H-550	Coupling CP
	0308690	H-550	Coupling RB
2.	5308381	H-552	Locking Ring – 12 per package
3.	5308696	H-553	O-Ring – 24 per package
4.	0308801	H-551-A	2-1/16" (53 mm) Tailpiece Assembly† CP
	0308802	H-551-A	2-1/16" (53 mm) Tailpiece Assembly† RB
	0308803	H-551-A	3-1/16" (78 mm) Tailpiece Assembly† CP
	0308805	H-551-A	4-1/16" (103 mm) Tailpiece Assembly† CP
	0308807	H-551-A	5-1/16" (129 mm) Tailpiece Assembly† CP
	0308809	H-551-A	6-1/16" (154 mm) Tailpiece Assembly† CP

† Each tailpiece assembly includes an H-553 O-Ring and an H-552 locking ring.

Abbreviations: CP: chrome plated; RB: rough brass

Sloan Valve Company can also provide products not shown in our current catalog. For our special finishes, consult factory for part numbers.

Tailpiece

NH-5 GROUND JOINT TAILPIECE CONNECTION

Older valves (prior to 1964), valves furnished for salt-water installations, and all Sloan flushometers furnished with straight stops use a metal-to-metal ground joint (GJ) tailpiece connection. The standard length of the H-5 tailpiece is 1-3/4" (44 mm) for a standard 4-3/4" (121 mm) rough-in dimension; other lengths are available in 1/4" (6 mm) increments.

The ground joint tailpiece connection cannot be adjusted in the field, so rough-in must be exact. Replacement NH-5 tailpieces can compensate for rough-in errors.

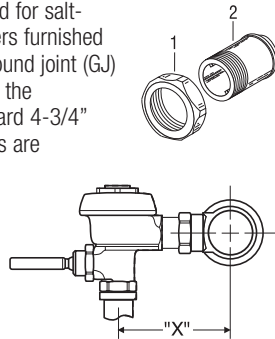

CHROME PLATED COMPONENTS

Item No.	Code No.	Description
1.	0308063	H-6 Coupling
2.	See below	NH-5 Ground Joint Tailpiece
	"X"	Tailpiece Length
	0308019	4-1/4" (108 mm) 1-1/4" (32 mm)
	0308023	4-1/2" (114 mm) 1-1/2" (38 mm)
	0308026	4-3/4" (121 mm) 1-3/4" (44 mm)
	0308030	5" (127 mm) 2" (51 mm)
	0308031	5-1/4" (133 mm) 2-1/4" (57 mm)
	0308033	5-1/2" (140 mm) 2-1/2" (64 mm)
	0308034	5-3/4" (146 mm) 2-3/4" (70 mm)
	0308035	6" (152 mm) 3" (76 mm)
	0308037	6-1/4" (159 mm) 3-1/4" (83 mm)
	0308038	6-1/2" (165 mm) 3-1/2" (89 mm)
	0308040	6-3/4" (171 mm) 3-3/4" (95 mm)
	0308041	7" (178 mm) 4" (102 mm)
	0308042	7-1/4" (184 mm) 4-1/4" (108 mm)
	0308043	7-1/2" (191 mm) 4-1/2" (114 mm)
	0308044	7-3/4" (197 mm) 4-3/4" (121 mm)
	0308045	8" (203 mm) 5" (127 mm)
	0308047	8-1/2" (216 mm) 5-1/2" (140 mm)
	0308050	9" (229 mm) 6" (152 mm)

ROUGH BRASS COMPONENTS

1.	0308063	H-6 Coupling
2.	See below	NH-5 Ground Joint Tailpiece
	"X"	Tailpiece Length
	0308028	4-3/4" (121 mm) 1-3/4" (44 mm)

NOTE: "X" indicates the distance between the centerline of valve and the centerline of the water supply. Ground joint couplings are notched for identification.

"XDT" FLUSHOMETER FOR CANADIAN TECK VALVES

Sloan can provide a flushometer with a tailpiece that can connect to a Cambridge Brass Teck (Wal-teck) supply stop. This special valve assembly is specified as our "-XDT" variation. This tailpiece cannot be replaced in the field.

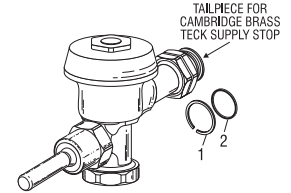

Item

No.	Code No.	Part No.	Description
1.	5308934	H-501	Locking Ring – 6 per package
2.	5308958	H-589	O-Ring – 6 per package

H-130-A ADJUSTABLE GROUND JOINT TAILPIECE CONNECTION

To accommodate adjustability in a ground joint connection, Sloan developed the H-130-A adjustable ground joint tailpiece connection. This is commonly supplied on valves used in retrofit applications where an existing ground joint supply stop (made by either Sloan or another manufacturer) is utilized. The H-130-A tailpiece is supplied as our "-XD" variation and requires a special valve body. It **cannot** be used to replace an H-551-A or an H-5 tailpiece.

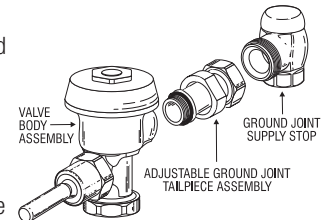

TO INSTALL THE ADJUSTABLE GROUND JOINT TAILPIECE:

NOTE: flushometer should be standing straight and not leaning to either side.

- Screw threaded end of the tailpiece into the flushometer body.
- Continue turning until tailpiece matches up to the end of the existing supply stop.
- Tighten the stop coupling to secure the valve to the supply stop.
- Using a flat-jawed wrench, tighten the valve coupling to secure the tailpiece to the valve.
- Continue flushometer installation according to the instructions packaged with the valve.

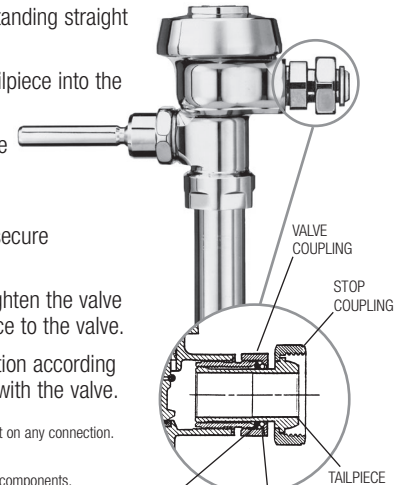

NOTE: DO NOT use pipe dope or thread sealant on any connection. Lubricate O-ring ONLY with water!

O-ring and stop ring are available as individual components. All other items are sold only in H-130-A tailpiece Retrofit Kit (see table below).

H-127 O-RING – 6 PER PACKAGE 5308973

H-128 STOP RING – 6 PER PACKAGE 5308974

TAILPIECE RETROFIT KIT

(WHEN USED WITH GROUND JOINT SUPPLY STOP)

Code No.	"X" †	Part No.
0308976	4-3/4" (121 mm)	H-130-A-1 †
0308983	5-3/4" (146 mm)	H-130-A-2
0308984	6-3/4" (171 mm)	H-130-A-3
0308979	7-3/4" (197 mm)	H-130-A-4

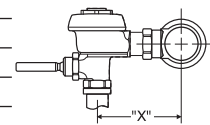

† When used with a Sloan ground joint supply stop, the tailpiece can be adjusted to a shorter or longer length (± 1/2" or 12 mm from the "X" dimension shown). When used with Delany ground joint supply stop, the tailpiece can be adjusted up to 1" (25 mm) longer from the "X" dimension shown.

‡ Unless otherwise specified, the H-130-A-1 tailpiece is furnished as standard with all "-XD" variation flushometer valves.

Flushometer Body Sub-assemblies

The tailpiece is the connection between the valve body and the control stop. Sloan adjustable tailpieces are threaded into the valve body at the factory. Sloan tailpieces are available in a variety of lengths to accommodate installation rough-in errors and unique installation requirements.

A3A CP FLUSHOMETER BODY ASSEMBLIES

A3A CP BODY SUB-ASM 2-1/16 ADJ TAIL
0301346PK

A3A CP BODY SUB-ASM 3-1/16 ADJ TAIL
0301629PK

A3A CP BODY SUB-ASM 4-1/16 ADJ TAIL
0301347PK

A3A CP BODY SUB-ASM 5-1/16 ADJ TAIL
0301348PK

A3A CP BODY SUB-ASM 6-1/16 ADJ TAIL
0301349PK

EBV36A CP FLUSHOMETER BODY ASSEMBLIES

EBV36A CP BODY SUB ASM 2-1/16 ADJ TAIL
0305381PK

EBV36A CP BODY SUB ASM 3-1/16 ADJ TAIL
0325075PK

EBV36A CP BODY SUB ASM 4-1/16 ADJ TAIL
0325179PK

The majority of flushometers supplied by Sloan since 1964 feature the H-551-A adjustable tailpiece. The valve tailpiece connects to the control stop with a sliding O-ring seal. The H-551-A adjustable tailpiece standard length is 2-1/16" (54 mm). This is designed for a standard flushometer installation in which the distance between the centerline of the valve and the centerline of the water supply inlet is 4-3/4" (121 mm). The adjustable tailpiece allows for a variance of ±1/2" (13 mm) from this nominal dimension.

A3A CP FLUSHOMETER

BODY ASSEMBLIES



A-3-A
2 1/16" Adjustable Tail (0301346PK)



A-3-A CP Body W 3-1/16"
Adjustable Tail (0301629PK)
For 5 1/4" - 6 1/4" Rough-in



A-3-A CP Body W 4-1/16" Adjustable Tail
(0301347PK)
For 6 1/4" - 7 1/4" Rough-in



A-3-A CP Body W 5-1/16" Adjustable Tail
(0301348PK)
For 7 1/4" - 8 1/4" Rough-in



A-3-A CP Body W 6-1/16" Adjustable Tail
(0301349PK)
For 8 1/4" - 9 1/4" Rough-in

EBV36A CP FLUSHOMETER

BODY ASSEMBLIES



EBV-36-A
2 1/16" Adjustable Tail (0305381PK)



EBV-36-A CP Body W 3-1/16"
Adjustable Tail (0325075PK)
For 5 1/4" - 6 1/4" Rough-in



EBV-36-A CP Body W 4-1/16"
Adjustable Tail (0325179PK)
For 6 1/4" - 7 1/4" Rough-in

Vacuum Breaker Trap Primer



ROYAL® FLUSHOMETER MODELS

- (Features high back pressure vacuum breaker)
- **VBF-72-A1**
- **VBF-73-A2** with 2" (50 mm) offset

REGAL® FLUSHOMETER MODELS

- **VBF-72-A2**
- **VBF-73-A2** with 2" (50 mm) offset

The Sloan vacuum breaker trap primer provides a constant water seal in a floor drain. Each time the flushometer is activated, a small amount of water is diverted to the floor drain to maintain the water seal. This seal prevents objectionable sewer gases from escaping into the air.

TABLE 1 †

Code No.	For Royal® or Regal® flushometer Model	"L" Length of Vacuum Breaker Flush Connection	"A" Centerline of Supply to Top of Bowl	"B" Centerline of Supply to Trap Primer Outlet	"C" Critical Line to Trap Primer Outlet
VBF-72-A1					
3396075	110/111 †	8-1/2" (216 mm)	11-1/2" (292 mm)	7" (178 mm)	2-1/4" (57 mm)
3396076	113/113-1.6	13" (330 mm)	16" (406 mm)	11" (280 mm)	6-1/4" (159 mm)
3396077	115/115-1.6	21" (533 mm)	24" (610 mm)	11" (280 mm)	6-1/4" (159 mm)
3396078	116/116-1.6	24" (610 mm)	27" (696 mm)	11" (280 mm)	6-1/4" (159 mm)
VBF-73-A2 With 2" (50 mm) Offset					
3396059	115/115-1.6	22-1/2" (572 mm)	25" (635 mm)	11" (280 mm)	6-1/4" (159 mm)

NOTE: For concealed style VB-75-A Trap Primer consult factory.
 † Refer to Figure A for dimensions "A," "B" and "C." Refer to Figure B for dimensions "L" and "C."
 ‡ Consult local codes for approval of the use of the VBF-72-A1 trap primer with flushometer models 110 and 111. Some codes require a minimum distance of 6" (153 mm) between the critical line of the vacuum breaker and the trap primer outlet. In these cases, specify models 113, 115 or 116.

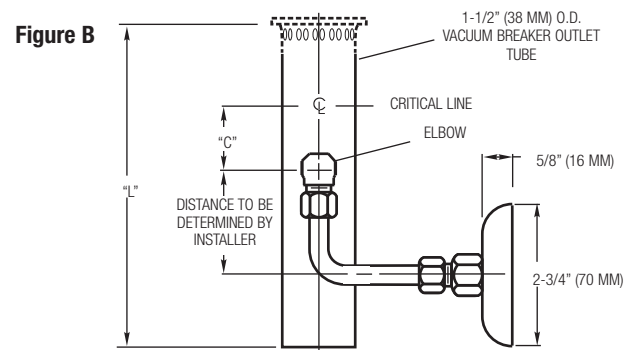
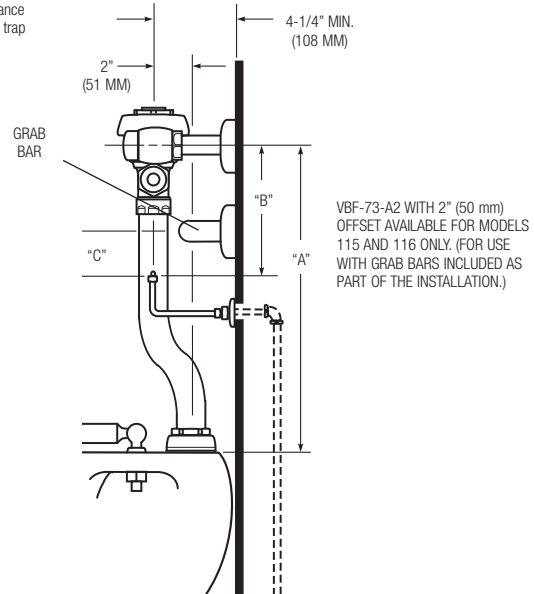
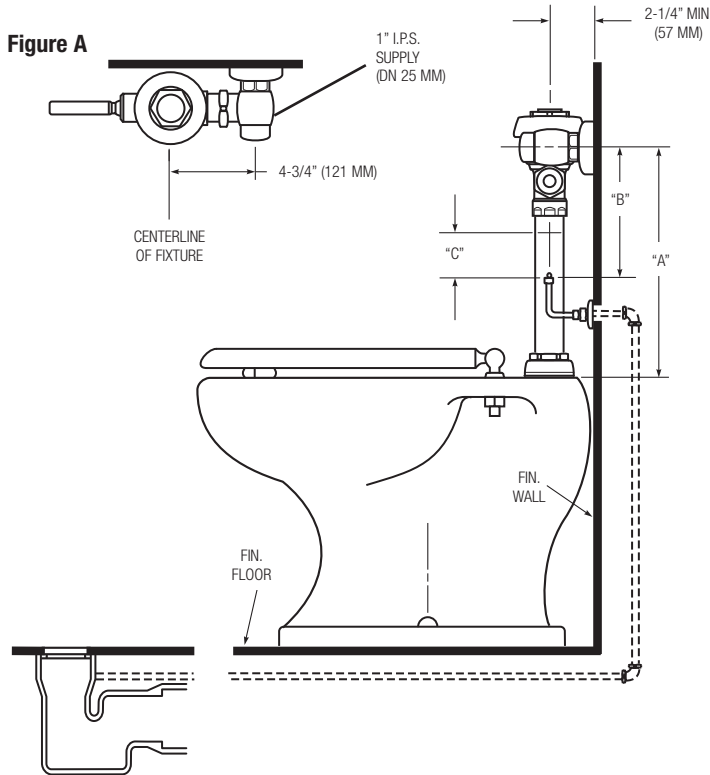

Vacuum Breaker Trap Primer

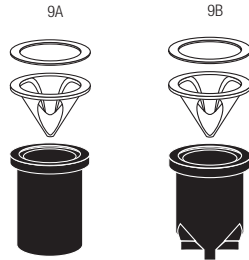
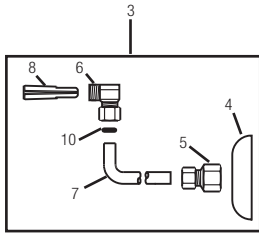
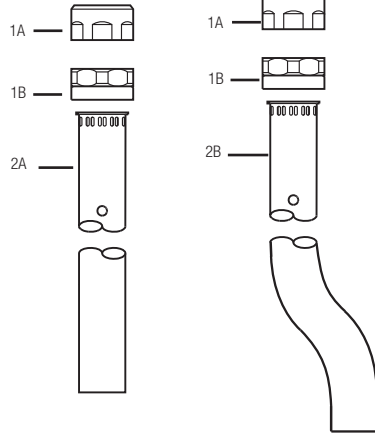
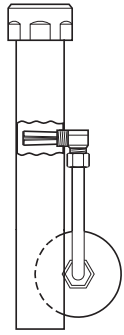

V-651 HIGH BACK PRESSURE VACUUM BREAKER REPAIR KIT



V-551 VACUUM BREAKER REPAIR KIT

PARTS LIST

Item No.	Code No.	Part No.	Description
1A.	0323304	V-579	Vacuum Breaker Coupling for Royal flushometers
1B.	0323120	V-553-A	Vacuum Breaker Coupling Assembly for Regal flushometers
2A.	—	VBF-2	1-1/2" (38 mm) x "L" Vacuum Breaker Outlet Tube (see Table 1 on page 102 for length)
2B.	—	VBF-4	1-1/2" (38 mm) x "L" Vacuum Breaker Outlet Tube with 2" (50 mm) Offset (see Table 1 on page 102 for length)
3.	0396067	F-75-AA	Assembly Kit for Trap Primer
4.	0306164	F-7	Wall Flange
5.	0396083	F-73-A	Tubing Fitting
6.	0396084	F-75-A	Elbow Compression Fitting
7.	0396085	F-76	3/8" (9 mm) x 12" (305 mm) Flexible Tubing
8.	0396089	F-88	Water Deflector
9A.	3323182	V- 651-A	High Back Pressure Vacuum Breaker Repair Kit (standard with Royal flushometers)
9B.	3323192	V- 551-A	Vacuum Breaker Repair Kit (standard with Sloan, Regal, GEM2, Dolphin & Naval flushometers)
10.	—	VBF-9	Restriction Washer

NOTE: For concealed style VB-75-A Trap Primer consult factory.

Vacuum Breaker Trap Primer

STEP 1 — INSTALL WATER DEFLECTOR AND ELBOW (FIGURE 1)

Insert the smaller end of the black plastic water deflector into the threaded end of the elbow fitting. The flat end of the elbow fitting will face outward from the vacuum breaker.

Place several drops of thread sealant on the threads of the elbow fitting. Insert the elbow fitting and water deflector into the threaded hole of the vacuum breaker tube. Screw the fitting into place. **DO NOT** overtighten this connection. The final position of the elbow should allow water flow from the vacuum breaker in a downward direction.

Figure 1

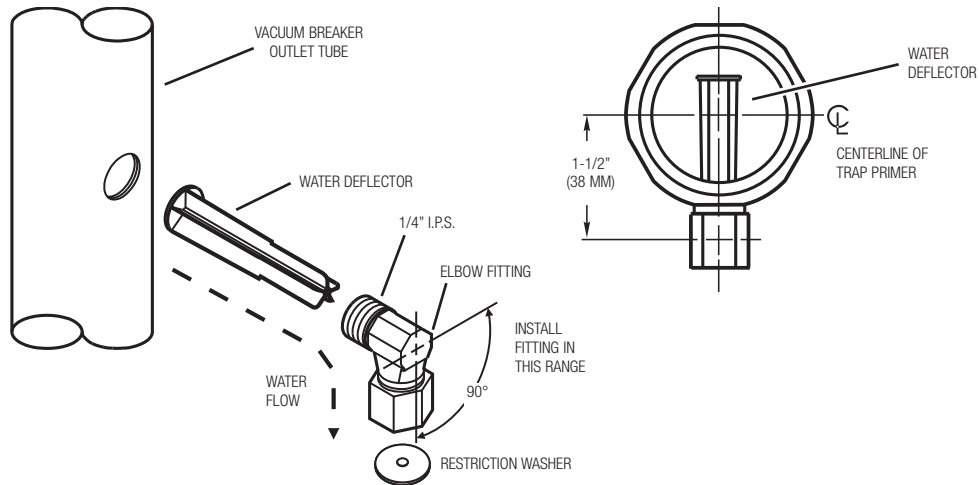

STEP 2 — INSTALL WALL FLANGE (FIGURE 2)

Place wall flange over the 1/2" (13 mm) NPT male pipe used as the trap primer outlet. Push wall flange until it is flush against the wall. Connect the 1/2" (13 mm) NPT female tube fitting to the pipe. The fitting will help keep the wall flange in position.

Figure 2

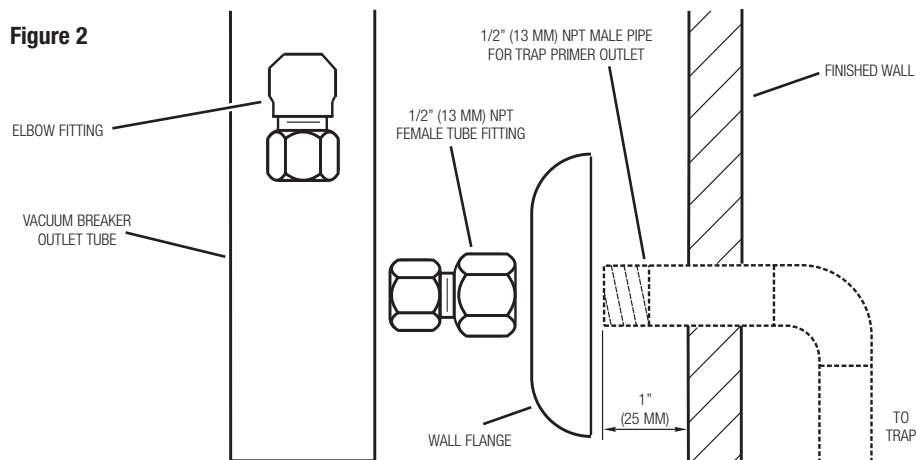

Vacuum Breaker Trap Primer

STEP 3 — INSTALL VACUUM BREAKER FLUSH CONNECTION (FIGURE 3)

Slide the spud coupling, nylon slip gasket, rubber gasket and spud flange (all supplied with a standard flushometer vacuum breaker) over the vacuum breaker tube and insert the tube into the fixture spud. Tighten the spud coupling onto the fixture spud by hand.

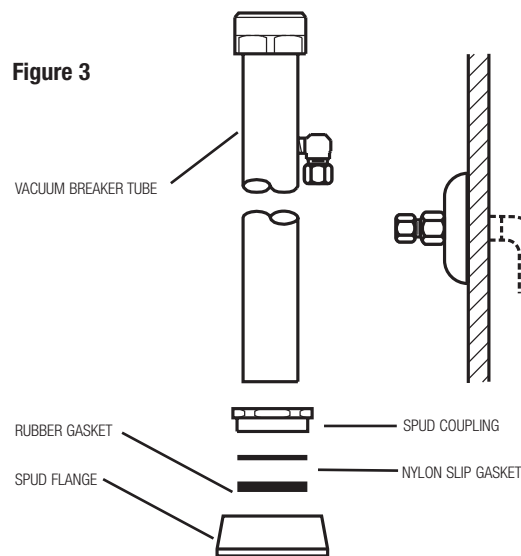

STEP 4 — INSTALL FLEXIBLE TUBING (FIGURE 4)

Use the 3/8" (9 mm) diameter flex tubing to connect the bottom of the elbow fitting with the restriction washer and the tube fitting at the wall flange. Sloan provides a 12" (305 mm) length of flex tubing. Cut tubing to appropriate length. Tighten compression fittings at both ends of the flex tubing. Complete the valve installation according to the installation instructions included with your Sloan flushometer valve.

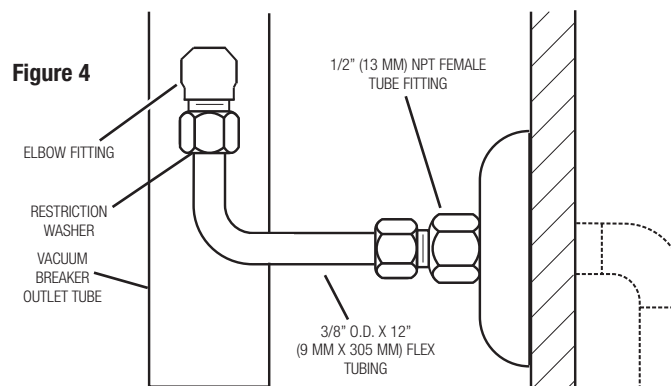

CARE AND CLEANING INSTRUCTIONS

DO NOT USE abrasive or chemical cleaners to clean flushometers, they may dull the luster and attack the chrome finish. Use **ONLY** mild soap and water, and then wipe dry with a clean towel or cloth. When cleaning, protect the exposed flushometer from any splattering of cleaner. Acids and cleaning fluids can discolor or remove chrome plating.

Small Vacuum Breaker Repair Kits

SMALL VACUUM BREAKER REPAIR KITS

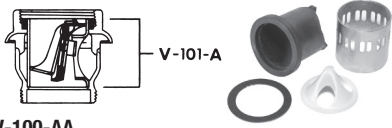
Code No.	Part No.	Description
		
For V-100-A & V-100-AA		
3322079	V-101-A	Repair Kit for V-101-A Vacuum Breaker with 1-1/2" Female IP Inlet and 1-1/2" Male IP Outlet

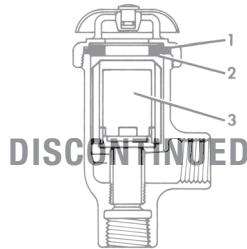

For V-300-A		
0322151	V-319-A	Repair Kit for V-300-A Vacuum Breaker includes Item Nos. 1-3

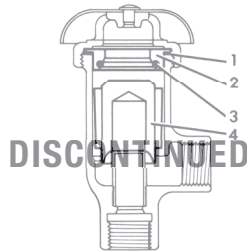

For V-350-A		
3322157	V-1000-A	Repair Kit for V-350-A Vacuum Breaker includes Item Nos. 1-4

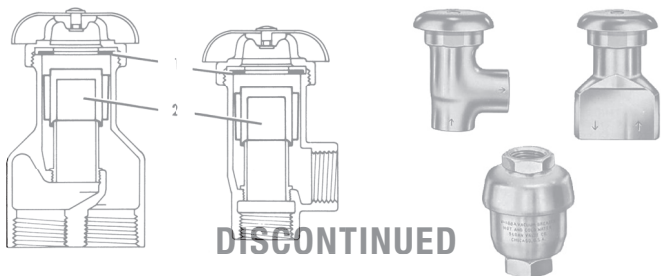
Code No.	Part No.	Description
		
DISCONTINUED		

For V-360-A & V-370-A		
3322284	V-382-A	Repair Kit for V-360-A & V-370-A 1/4" includes Item Nos. 1 & 2
3322277	V-362-A	Repair Kit for V-360-A & V-370-A 3/8" includes Item Nos. 1 & 2
3322294	V-388-A	Repair Kit for V-360-A & V-370-A 1/2" includes Item Nos. 1 & 2
3322302	V-392-A	Repair Kit for V-360-A & V-370-A 3/4" includes Item Nos. 1 & 2

NOTE: For suitable replacements, contact factory.

Push, Pull, Pedal Push, and Pedal Handle Push Button

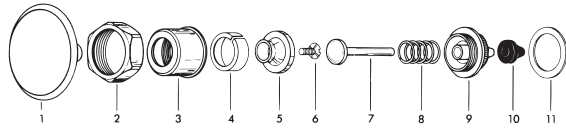

Item

No.	Code No.	Part No.	Description
Repair Kits			
	3303396	C-64-A	Push Button Repair Kit contains item nos. 7-11
	3303347	C-1000-A	Replacement Kit contains item nos. 1,5 & 6
Repair Parts			
1-11.	0303351	C-42-A	Push Button Assembly
1.	*	C-42	3" Push Button CP
2.	0301082	A-6	CP Coupling
3-4.	0302109	B-7-A	Socket
5.	*	C-41	Shank Head
6.	*	C-43	Screw RB
7.	*	B-8-A	Plunger
8.	0303019	C-7	Spring
9.	*	B-49	Bushing
10.	5302297	B-39	Seal
11.	5301139	A-31	Gasket

*Available in kit only.

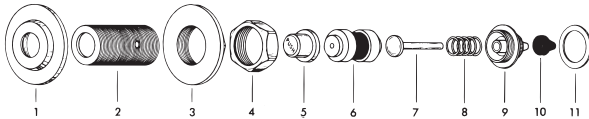

Push Button For Concealed Royal® & Crown®

No.	Code No.	Part No.	Description
Item			
Repair Kits			
	—	C-9-A	Complete Push Button Assembly. Items 1-11. Consult factory.
	3303399	C-77-A	Push Button Repair Kit contains item nos. 7-11
Repair Parts			
1.	0302248	B-23	CP Wall Flange 2-3/4" O.D.
	0302252	B-23	CP Wall Flange 2-3/4" O.D. w/Set Screw
2.	—	B-6/B-6-A	In-Wall Sleeve. If required, consult factory.
3.	0302260	B-24	RB Locknut
4.	0301082PO	A-6	RB Coupling
5.	0303002	C-2	Index Push Button
6.	—	B-15-A	N/A. Multiple lengths available. Consult factory.
7.	*	B-8-A	Plunger
8.	*	C-7	Spring
9.	*	B-41	Bushing
10.	—	B-85	Permex® Seal
11.	5301139	A-31	Gasket

*Available in kit only. †Wall Box Assembly for C-43-AWB/C-9-AWB/B-12-AWB

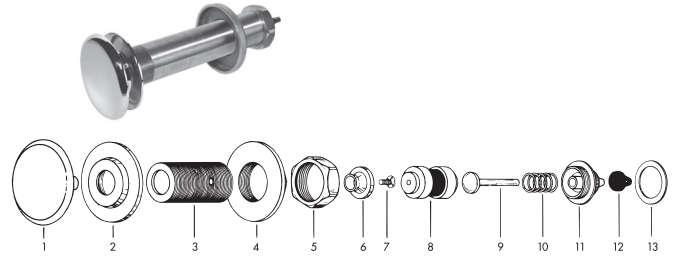

3" Push Button For Concealed Royal® & Crown®

No.	Code No.	Part No.	Description
Item			
Repair Kits			
	—	C-43-A	3" Push Button Assembly. Items 1-13. Consult factory.
	3303398	C-70-A	Push Button Repair Kit contains item nos. 9-13*
	3303399	C-77-A	Push Button Repair Kit contains item nos. 9-13 – Triple Seal Cone Seal*
	3303347	C-1000-A	Replacement Kit contains item nos. 1,6 & 7
Repair Parts			
1.	*	C-42	3" Push Button CP
2.	0302248	B-23	CP Wall Flange 2-3/4" O.D.
	0302252	B-23	CP Wall Flange 2-3/4" O.D. w/Set Screw for Wall Box Installation †
3.	—	B-6/B-6-A	In-Wall Sleeve. If required, consult factory.
4.	0302260	B-24	RB Locknut
5.	0301083	A-6	RB Coupling
6.	*	C-41	Shank Head
7.	*	C-43	RB Screw
8.	—	B-15-A	N/A. Multiple lengths available. Consult factory.
9.	*	B-8-A	Plunger
10.	0303019	C-7	Spring
11.	*	B-41	Bushing
12.	5302297	B-39	Seal
13.	5301139	A-31	Gasket

*Available in kit only.

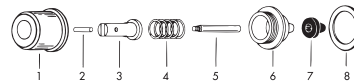

No.	Code No.	Part No.	Description
Item			
Repair Kit			
	3303393	C-61-A	Repair Kit contains item nos. 4-9
Repair Parts			
1.	0303174	C-25	Socket
2.	5303213	C-29	RB Pin
3.	0303155	C-23	CP Plunger Sleeve
4.	*	C-28	Spring
5.	*	C-24	Plunger Stem
6.	*	C-61	Bushing
7.	5302297	B-39	Seal
8.	5301139	A-31	Gasket

*Available in kit only.

Push, Pull, Pedal Push, and Pedal Handle Push Button

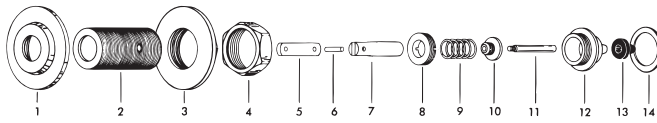

Pull Button For Concealed Royal® & Crown® (Seat Action)

Item

No.	Code No.	Part No.	Description
-----	----------	----------	-------------

Repair Kit

	3303394	C-62-A	Repair Kit contains item nos. 9-14
--	----------------	--------	------------------------------------

Repair Parts

1.	0302248	B-23	CP Wall Flange 2-3/4" O.D.
2.	—	C-30	In-Wall Sleeve. If required, consult factory.
3.	0302260	B-24	RB Locknut
4.	0301083	A-6	RB Coupling
5.	—	C-27	Link Available in Multiple Lengths. Consult factory.
6.	5303213	C-29	RB Pin
7.	—	C-31	Sleeve Available in Multiple Lengths. Consult factory.
8.	0203013	C-48	RB Sleeve Guide
9.	*	C-28	Spring
10.	*	C-32	Plunger Head
11.	*	C-24	Plunger Stem
12.	*	C-61	Special Bushing
13.	5302297	B-39	Seal
14.	5301139	A-31	Gasket

*Available in kit only.

Pedal Push Button For Exposed Royal® & Crown®

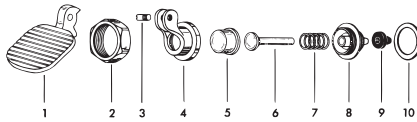

**Item No.
Code No.
Part No.**

Description

Repair Kit

	3302304	B-40-A	Repair Kit contains item nos. 4-10
--	----------------	--------	------------------------------------

Repair Parts

1-10.	0303289	C-33-A	Pedal RB Assembly
1.	0303293	C-34	CP Pedal
2.	0301082	A-6	Coupling
3.	5303298	C-35	CP Screw
4.	*	C-33	CP Socket
5.	*	C-37	CP Push Button
6.	*	B-8-A	Plunger (Special)
7.	0303019	C-7	Spring
8.	*	B-49	Bushing
9.	5302297	B-39	Seal
10.	5301140	A-31-P	Gasket

*Available in kit only.

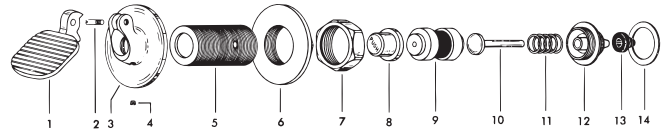

Pedal Push Button For Concealed Royal® & Crown®

Item

No.	Code No.	Part No.	Description
-----	----------	----------	-------------

Repair Kit

	—	C-40-A	Complete Pedal Push Button Assembly item nos. 1-14 LDIM required
	3303398	C-70-A	Push Button Repair Kit contains item nos. 10-14
	3303399	C-77-A	Push Button Repair Kit contains item nos. 10-14 – Triple Seal Cone Seal

Repair Parts

1.	0303293	C-34	CP Pedal
2.	5303298	C-35	CP Screw
3-4.	0303303	C-40	CP Flange w/Set Screw
5.	—	B-6	In-Wall Sleeve. If required, consult factory.
6.	0302260	B-24	RB Locknut
7.	0301082PO	A-6	RB Coupling
8.	0303002	C-2	Index Push Button
9.	—	B-15-A	N/A. Multiple lengths available. Consult factory.
10.	*	B-8-A	Plunger
11.	0303019	C-7	Spring
12.	*	B-41	Bushing
13.	5302297	B-39	Seal
14.	5301139	A-31	Gasket

*Available in kit only.

Pedal Handle Push Button For Exposed Royal® & Crown®

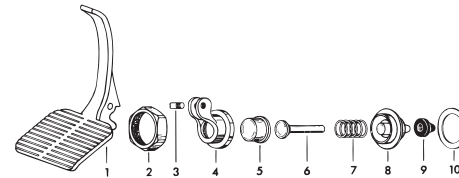

Item

No.	Code No.	Part No.	Description
-----	----------	----------	-------------

Repair Kit

	3302304	B-40-A	Repair Kit contains item nos. 4-10
--	----------------	--------	------------------------------------

Repair Parts

1-10.	0303290	C-33-A	Pedal Handle PB Assembly – DISCONTINUED
1.	0303295	C-34	CP Pedal Handle – DISCONTINUED
2.	0301082	A-6	Coupling
3.	5303298	C-35	CP Screw
4.	*	C-33	CP Socket
5.	*	C-37	CP Push Button
6.	*	B-8-A	Plunger (Special)
7.	0303019	C-7	Spring
8.	*	B-49	Bushing
9.	5302297	B-39	Seal
10.	5301140	A-31-P	Gasket

*Available in kit only.

Push, Pull, Pedal Push, and Pedal Handle Push Button

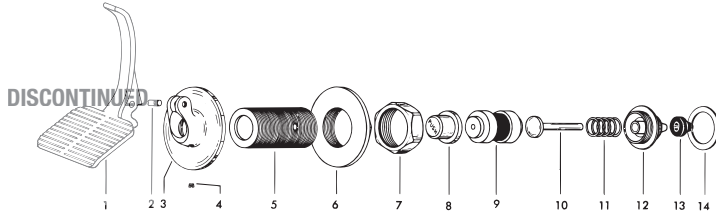

Pedal Handle Push Button For Concealed Royal® & Crown®

Item No.	Code No.	Part No.	Description
Repair Kit			
—	C-40-A	Complete Pedal Handle Push Button Assembly. Items 1-14. Consult factory – DISCONTINUED	
Repair Parts			
1.	0303295	C-34	CP Pedal Handle – DISCONTINUED
2.	5303298	C-35	CP Screw
3-4.	0303303	C-40	CP Flange w/Set Screw
5.	—	B-6/B-6-A	In-Wall Sleeve. If required, consult factory.
6.	0302260	B-24	RB Locknut
7.	0301082PO	A-6	RB Coupling
8.	0303002	C-2	Index Push Button
9.	—	B-15	N/A. Multiple lengths available. Consult factory.
10.	*	B-8-A	Plunger
11.	0303019	C-7	Spring
12.	*	B-41	Bushing
13.	5302297	B-39	Seal
14.	5301139	A-31	Gasket

*Available in kit only.

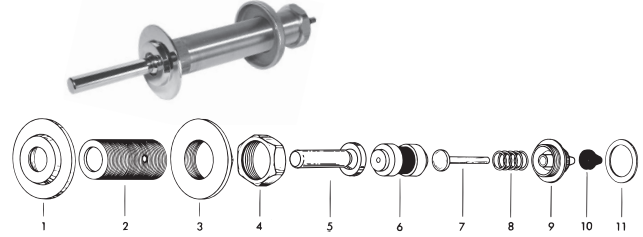

Handle For Concealed Royal® & Crown®

Item No.	Code No.	Part No.	Description
Repair Kit			
3303398	C-70-A	CP ADA-Compliant Triple Seal Handle Assembly	
Repair Parts			
1	0302248	B-23	CP Wall Flange 2-3/4" O.D.
	0302252	B-23	CP Wall Flange 2-3/4" O.D. w/Set Screw for Wall Box Installation †
2.	—	B-6/B-6-A	In-Wall Sleeve. If required, consult factory.
3.	0302260	B-24	RB Locknut
4.	0301082PO	A-6	RB Coupling
5.	0302389	B-74-A	CP ADA-Compliant Handle
6.	—	B-15-A	N/A. Multiple lengths available. Consult factory.
7.	*	B-8-A	Plunger
8.	*	C-7	Spring
9.	*	B-41	Bushing
10.	5302297	B-39	Seal
11.	5301139	A-31	Gasket

*Available in kit only. †Wall Box Assembly for C-43-AWB/C-9-AWB/B-12-AWB

"L" Dimension PUSH BUTTON ID CHART (All dimensions in inches)

Wall Thickness	1	2	3	4	5	6	7	8	9	10	11	12	13	14	15
"L" Dimension	3 3/4	4 3/4	5 3/4	6 3/4	7 3/4	8 3/4	9 3/4	10 3/4	11 3/4	12 3/4	13 3/4	14 3/4	15 3/4	16 3/4	17 3/4
"A" (B-15-A) Filler Rod	1 5/8	2 5/8	3 5/8	4 5/8	5 5/8	6 5/8	7 5/8	8 5/8	9 5/8	10 5/8	11 5/8	12 5/8	13 5/8	14 5/8	15 5/8
"B" (B-6-A) Socket Assembly	2 1/2	3 1/2	4 1/2	5 1/2	6 1/2	7 1/2	8 1/2	9 1/2	10 1/2	11 1/2	12 1/2	13 1/2	14 1/2	15 1/2	16 1/2

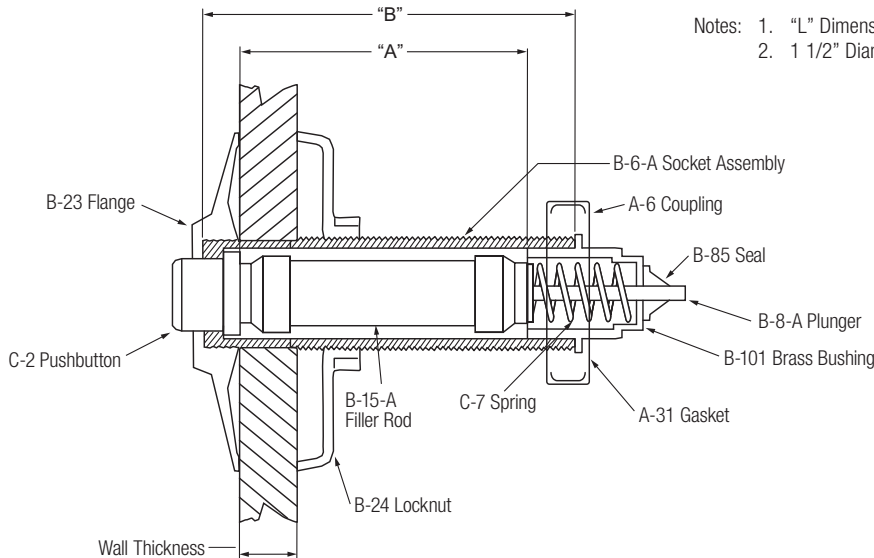

Notes: 1. "L" Dimension = Wall thickness (to nearest whole inch) + 2 3/4"
 2. 1 1/2" Diameter Hole Opening Required Through Wall



Push, Pull, Pedal Push, and Pedal Handle Push Button

REPAIR KIT AND BUSHING ID CHART

B-101 RB Bushing

Used in C-70-A repair kit & C-77-A repair kit. For concealed valve Actuators: B-12-A, C-9-A, C-43-A, B-17-A

Note: Can NOT be used on Institutional/Prison Lav valves where an inside thread is required.

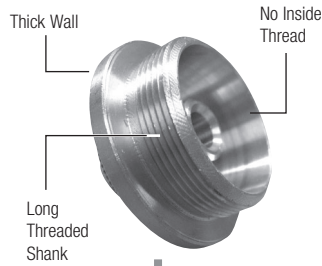

C-70-A Repair Kit

The C-70-A repair kit is for concealed valves using the B-12-A, C-9-A, C-43-A, C-40-A or B-17-A actuator assembly.

Note: Can NOT be used on Institutional/Prison Lav valves where an inside thread is required.

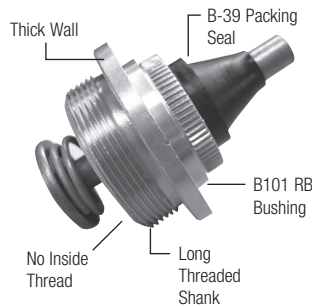

C-77-A Repair Kit (Royal)

The C-77-A repair Kit is the same as the C-70-A repair kit only it uses the B-85 Packing Seal (upgrade), not the B-39. It is a repair kit for concealed valves using B-12-A, C-9-A, C-43-A or B-17-A actuator assembly. It is also in the Concealed Royal Performance repair kit, A-1201-08-A series.

Note: Can NOT be used on Institutional/Prison Lav valves where an inside thread is required.

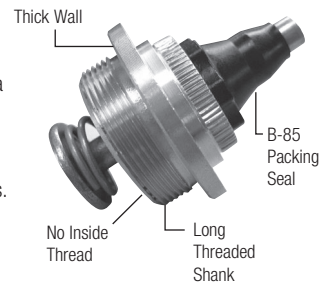

B-41 RB Bushing

Used on the C-69-A Assembly for Institutional/Prison Lav valves. Used in the C-63-A repair kit.

Note: MAIN USE IS THE INSIDE THREAD.

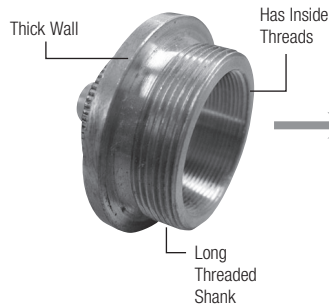

C-63-A Repair Kit

Used on the C-69-A Assembly for Institutional/Prison Lav valves. Used in the C-63-A repair kit.

Note: MAIN USE IS THE INSIDE THREAD.

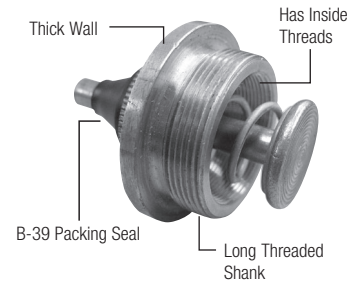

B-49 RB Bushing

Used only on exposed valves using C-42-A (3" push button) or C-33-A (pedal) actuators. Used in C-64-A repair kit for 3" push button only. C-64-A can NOT be used to repair C-33-A pedal valves, use B-40-A.

Note: CAN be used in a handle repair kit for heavy duty use.

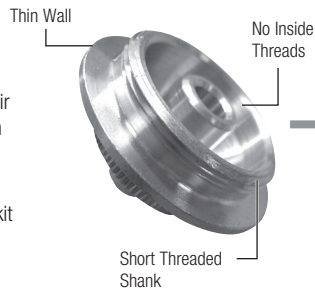

C-64-A Repair Kit

Used only on exposed valves using C-42-A (3" push button). Can NOT be used to repair C-33-A pedal valves, use B-40-A.

Note: CAN be used as a handle repair kit for heavy duty use, exposed valves.

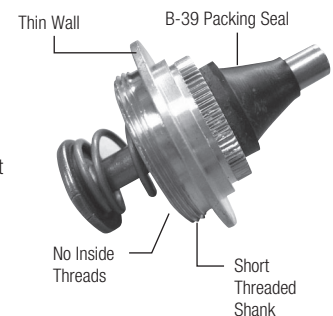

B-40-A Exposed Pedal Valve

Actuator repair kit.



Flush Connections and Flanges

Complete Flush Connection Assemblies Chrome Plate Finish for Exposed Installations

Code No.	Part No.	Description
----------	----------	-------------

For Models 110/111

0393007	V-600-AA	CP Vacuum Breaker 1-1/2" x 9"
0306146	F-5-AT	CP Spud Coupling 1-1/2" x 3"

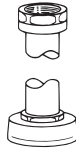

For Model 113

0393008	V-600-AA	CP Vacuum Breaker 1-1/2" x 13-1/2"
0306146	F-5-AT	CP Spud Coupling 1-1/2" x 3"

For Model 114

0393011	V-600-AA	CP Vacuum Breaker 1-1/2" x 32-1/2"
0306146	F-5-AT	CP Spud Coupling 1-1/2" x 3"

For Model 115

0393009	V-600-AA	CP Vacuum Breaker 1-1/2" x 21-1/2"
0306146	F-5-AT	CP Spud Coupling 1-1/2" x 3"

For Model 116

0393010	V-600-AA	CP Vacuum Breaker 1-1/2" x 24-1/2"
0306146	F-5-AT	CP Spud Coupling 1-1/2" x 3"

For Model 117

0393009	V-600-AA	CP Vacuum Breaker 1-1/2" x 21-1/2"
0306146	F-5-AT	CP Spud Coupling 1-1/2" x 3"

For Model 180

0393006	V-600-AA	CP Vacuum Breaker 1-1/4" x 9"
0306140	F-5-AU	CP Spud Coupling 1-1/4" x 3"

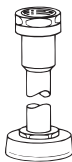

For Model 186

0393004	V-600-AA	CP Vacuum Breaker 3/4" x 9"
0306125	F-5-AW	CP Spud Coupling 3/4" x 2-1/2"

For Model 300/310

0306060	F-2-AU	CP Coupling 1-1/4"
0306146	F-5-AT	CP Spud Coupling 1-1/2" x 3"
0306196	F-7	CP Flange w//Prongs 1" x 2-3/4"
0306209	F-7	CP Flange Flat 1-1/4" x 3-1/8"
0306555	F-21-AA	Elbow 1-1/2" x 1-1/4" x 4"
0393007	V-600-AA	CP Vacuum Breaker 1-1/2" x 9"
0396009	F-43-A	CP Outlet & Street El 1"
0396093	F-101	CP Outlet

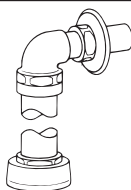

For Model 320

0301149	A-35	Reducer Bushing 1" NPT x 3/4 NPT
0306052	F-2-AW	CP Coupling Assembly 3/4"
0306125	F-5-AW	CP Spud Coupling 3/4" x 2-1/2"
0306188	F-7	CP Flange Flat 3/4" x 2-23/32"
0306343	F-15-A	CP Elbow Tail Assembly 3/4" x 4"
0393004	V-600-AA	Vacuum Breaker 3/4" x 9"
0396009	F-43-A	CP Outlet & Street El 1"
0396093	F-101	CP Outlet 1-1/2" x 4-1/2"

Complete Flush Connection Assemblies Chrome Plate Finish for Exposed Installations (continued)

Code No.	Part No.	Description
----------	----------	-------------

For Model 120

0306093	F-2-AT	CP Coupling 1-1/2"
0393003	V-600-A	CP Vacuum Breaker
0396293	F-109	CP Tube 1-1/2" x 8" x 5" Bend
0306146	F-5-AT	CP Spud Coupling 1-1/2" x 3"

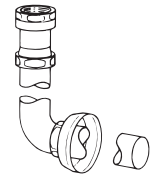

For Model 121

0306093	F-2-AT	CP Coupling 1-1/2"
0393003	V-600-A	CP Vacuum Breaker
0396316	F-109	CP Tube 1-1/2" x 13" x 5" Bend
0306146	F-5-AT	CP Spud Coupling 1-1/2" x 3"

For Model 122

0306093	F-2-AT	CP Coupling 1-1/2"
0393003	V-600-A	CP Vacuum Breaker
0396322	F-109	CP Tube 1-1/2" x 21" x 5" Bend
0306146	F-5-AT	CP Spud Coupling 1-1/2" x 3"

For Model 136

0393038	V-600-AA	CP Vacuum Breaker 1-1/2" x 36"
0306146	F-5-AT	CP Spud Coupling 1-1/2" x 3"

For Model 137

0306093	F-2-AT	CP Coupling 1-1/2"
0393003	V-600-A	CP Vacuum Breaker
0396339	F-109	CP Tube 1-1/2" x 36" x 5"
0306146	F-5-AT	CP Spud Coupling 1-1/2" x 3"

Drip Pocket Flush Connection Assemblies and Parts

DP-4-A Includes:

0330015	DP-4-A	Drip Pocket
0330026	DP-1002-A	Float & Seat Repair Kit For DP-4-A
0330002	DP-2-A	Drip Pocket Wall Support (Available upon request)

DP-6-A Includes:

0330021	DP-6-A	1-1/2" x 18-1/2" CP Outlet
----------------	--------	----------------------------

DP-7-A Includes:

0330002	DP-2-A	D.P. Wall Support
0330015	DP-4-A	Drip Pocket Assembly
0330021	DP-6-A	Drip Pocket Flush Connection
0330004	F-33	Extension Nipple

Use on the following flush valve: 118

Special F-33 Includes:

0330004	F-33	Extension for DP-4-A
----------------	------	----------------------

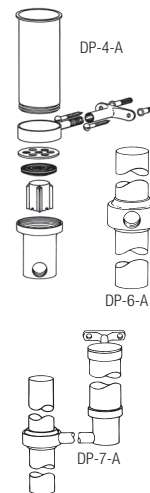

Flush Connections and Flanges

Complete Flush Connection Assemblies Rough Brass Finish for Concealed Installations

Code No.	Part No.	Description
For Model 150		
0323011	V-500-A	RB Vacuum Breaker
0306087	F-2-A	RB 1-1/2" Coupling w/S30
0306569	F-22	RB Outlet 1" NPT Female

For Model 152

0323177	V-500-AA	RB Vacuum Breaker 1-1/2" x 22" w/ 10-1/2" Score
0206146	F-21	RB 1-1/2" El Double Male Slip
0306091	F-2-A	RB 1-1/2" Coupling w/S21
0306619	F-2-AA	RB Two Sets F-2-A 1-1/2" Coupling
—	F-100	RB Outlet - Specify Size

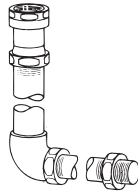

For Model 153/155

0206146	F-21	RB 1-1/2" El Double Male Slip
0306146	F-5-AT	CP Spud Coupling 1-1/2" x 3"
0306237	F-7	CP Flange w/Prongs 1-1/2" x 2-3/4"
0306400	F-15-A	CP Elbow 1-1/2" x 4"
0306619	F-2-AA	RB Two Sets F-2-A 1-1/2" SJ Coupling
0323176	V-500-AA	1-1/2" x 17-1/2" w/ 3" Score
—	F-102	CP Outlet - Specify Size

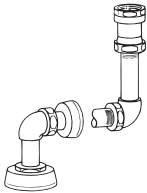

For Model 154

0206146	F-21	RB 1-1/2" El Double Male Slip
0306091	F-2-A	RB 1-1/2" Coupling w/S21
0306146	F-5-AT	CP Spud Coupling 1-1/2" x 3"
0306237	F-7	CP Flange 1-1/2" x 2-3/4" w/Prongs
0306619	F-2-AA	RB Two Sets F-2-A 1-1/2" SJ Coupling
0323177	V-500-AA	RB Vacuum Breaker 1-1/2" x 22" w/ 10-1/2" Score
—	F-102	CP Outlet - Specify Size

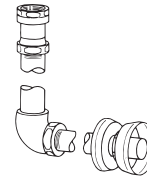

For Model 140

0206146	F-21	RB 1-1/2" El Double Male Slip
0306146	F-5-AT	CP Spud Coupling 1-1/2" x 3"
0306237	F-7	CP Flange w/Prongs 1-1/2" x 2-3/4"
0306619	F-2-AA	RB Two Sets F-2-A 1-1/2" SJ Coupling
0306688	F-25-A	RB Elbow/Tail 1-1/2" x 10" C/E w/ 3" Score
0323188	V-500-AA	RB Vacuum Breaker 1-1/2" x 11-1/2" w/ 3" Score
—	F-102	CP Outlet - Specify Size

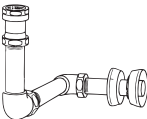

For Model 142

0206146	F-21	RB 1-1/2" El Double Male Slip
0306146	F-5-AT	CP Spud Coupling 1-1/2" x 3"
0306237	F-7	CP Flange w/Prongs 1-1/2" x 2-3/4"
0306400	F-15-A	CP Elbow 1-1/2" x 4"
0306619	F-2-AA	RB Two Sets F-2-A 1-1/2" SJ Coupling
0306688	F-25-A	RB Elbow/Tail 1-1/2" x 10 C/E w/ 3" Score
0323207	V-500-AA	RB Vacuum Breaker 1-1/2" x 6" w/ 3" Score
—	F-102	CP Outlet - Specify Size

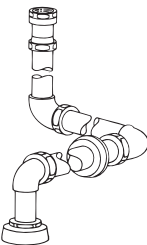

Complete Flush Connection Assemblies Rough Brass Finish for Concealed Installations (continued)

Code No.	Part No.	Description
For Model 143		
0206146	F-21	RB 1-1/2" El Double Male Slip
0306091	F-2-A	RB 1-1/2" Coupling w/S21
0306619	F-2-AA	RB Two Sets F-2-A 1-1/2" SJ Coupling
0306688	F-25-A	RB Elbow/Tail 1-1/2" x 10" C/E w/ 3" Score
0323188	V-500-AA	RB Vacuum Breaker 1-1/2" x 11-1/2" w/ 3" Score
—	F-100	RB Outlet - Specify Size

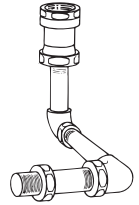

For Model 144

0206146	F-21	RB 1-1/2" El Double Male Slip
0306091	F-2-A	RB 1-1/2" Coupling w/S21
0306619	F-2-AA	RB Two Sets F-2-A 1-1/2" SJ Coupling
0306688	F-25-A	RB Elbow/Tail 1-1/2" x 10" C/E w/ 3" Score
0323208	V-500-AA	RB Vacuum Breaker 1-1/2" x 7-1/2" w/ 3" Score
—	F-100	RB Outlet - Specify Size

For Model 192

0206146	F-21	RB 1-1/2" El Double Male Slip
0306140	F-5-AU	CP Spud Coupling
0306237	F-7	CP Flange w/Prongs 1-1/2" x 2-3/4"
0306472	F-15-A	CP Elbow/Tail 1-1/2" x 1-1/4" x 4"
0306619	F-2-AA	RB Two Sets F-2-A 1-1/2" SJ Coupling
0323188	V-500-AA	RB Vacuum Breaker 1-1/2" x 11-1/2" w/ 3" Score
—	F-102	CP Outlet - Specify Size

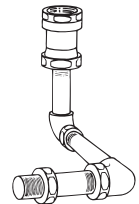

For Model 195

0306054	F-2-AW	RB Coupling 3/4"
—	F-15-A	Specify Size
0323003	V-500-AA	RB Vacuum Breaker 3/4" x 10-1/2"

For Model 197

0306125	F-5-AW	CP Spud Coupling 3/4" x 2-1/2"
0306186	F-7	CP Flange 3/4" x 2-3/4"
0306375	F-15-A	CP Elbow/Tail 3/4" x 5"
0306376	F-15-A	CP Elbow/Tail 3/4" x 14"
0323003	V-500-AA	RB Vacuum Breaker 3/4" x 10-1/2"

For Model 190

0206146	F-21	RB 1-1/2" El Double Male Slip
0306059	F-2-AU	RB Coupling 1-1/4"
0306088	F-2-AT	RB Coupling 1-1/2"
0306091	F-2-A	RB 1-1/2" Coupling w/S21
0323188	V-500-AA	RB Vacuum Breaker 1-1/2" x 11-1/2" w/3" Score
—	F-110	Specify Size

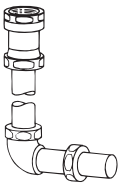

Flush Connections and Flanges

Complete Flush Connection Assemblies Rough Brass Finish for Concealed Installations (continued)

Code No.	Part No.	Description
For Model 312		
0306060	F-2-AU	CP Coupling 1-1/4"
0306087	F-2-A	RB 1-1/2" Coupling w/S30
0306146	F-5-AT	CP Spud Coupling 1-1/2" x 3"
0306209	F-7	CP Flange Flat 1-1/4" x 3-1/8"
0306555	F-21-AA	CP Elbow 1-1/2" x 1-1/4" x 4"
0306569	F-22	RB Outlet 1" NPT Female x 1-1/2"
0393007	V-600-AA	CP Vacuum Breaker 1-1/2" x 9"



For Model 313		
0206146	F-21	RB 1-1/2" EI Double Male Slip
0306087	F-2-A	RB 1-1/2" Coupling w/S30
0306091	F-2-A	RB 1-1/2" Coupling w/S21
0306569	F-22	RB Outlet 1" NPT Female x 1-1/2"
0306619	F-2-AA	RB Two Sets F-2-A 1-1/2" SJ Coupling
0322026	V-79	RB 1" Adapter
0323188	V-500-AA	RB Vacuum Breaker 1-1/2" x 11-1/2" w/3" Score
—	F-100	RB Outlet

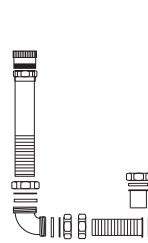

For Model 318		
0206146	F-21	RB 1-1/2" EI Double Male Slip
0306087	F-2-A	RB 1-1/2" Coupling w/S30
0306146	F-5-AT	CP Spud Coupling 1-1/2" x 3"
0306237	F-7	CP Flange w/Prongs 1-1/2" x 2-3/4"
0306569	F-22	RB Outlet 1" NPT Female x 1-1/2"
0306619	F-2-AA	RB Two Sets F-2-A 1-1/2" SJ Coupling
0322026	V-79	RB 1" Adapter
	F-102	CP Outlet - Specify Size
0323188	V-500-AA	RB Vacuum Breaker 1-1/2" x 11-1/2" w/3" Score

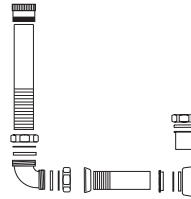

For Model 323		
0206160	F-22	RB 3/4" Outlet Female
0306054	F-2-AW	RB 3/4"
0306087	F-2-A	RB 1-1/2" Coupling w/S30
0306366	F-15-A	RB Elbow Tail Assembly 3/4" x 11"
0322021	V-79	RB 3/4" Adapter Inlet
0323003	V-500-AA	RB Vacuum Breaker 3/4" x 10-1/2"

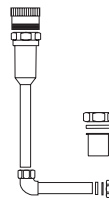

For Model 343		
0206146	F-21	RB 1-1/2" EI Double Male Slip
0306059	F-2-AU	RB Coupling 1-1/4"
0306087	F-2-A	RB 1-1/2" Coupling w/S30
0306091	F-2-A	RB 1-1/2" Coupling w/S21
0306569	F-22	RB Outlet 1" NPT Female x 1-1/2"
0322026	V-79	RB 1" Adapter
0323188	V-500-AA	RB Vacuum Breaker 1-1/2" x 11-1/2" w/ 3" Score
—	F-110	RB 1-1/2" Flange x 1-1/4" Tube w/Score

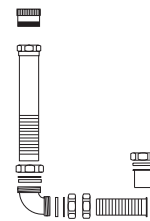

For Model 139		
0206146	F-21	RB 1-1/2" EI Double Male Slip
0306619	F-2-AA	RB Two Sets F-2-A 1-1/2" Coupling
0323312	V-500-AA	RB Vacuum Breaker 1-1/2" x 33-1/2" w/3" Score
0396210	F-102	RB Tube 1-1/2" x 10" w/Score

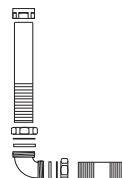

Flush Connections and Flanges

Couplings and Gaskets

Item No.	Code No.	Part No.	Description
F-2-A			
1-3.	0306052	F-2-A	3/4" CP Coupling Assembly
	0306054	F-2-A	3/4" RB Coupling Assembly
	0306077	F-2-A	1" CP Coupling Assembly
	0306060	F-2-A	1-1/4" CP Coupling Assembly
	0306059	F-2-A	1-1/4" RB Coupling Assembly
	0306093	F-2-A	1-1/2" CP Coupling Assembly
	0306088	F-2-A	1-1/2" RB Coupling Assembly
3-4	0306092	F-2-A	1-1/2" CP Coupling Assembly
	0306087	F-2-A	1-1/2" RB Coupling Assembly
1.	5306113	F-5	3/4" SJ Gasket
	5306115	F-5	1" SJ Gasket
	5322176	VPF-5	1-1/4" SJ Gasket
	5322001	VPF-5	1-1/2" SJ Gasket
2.	5306055	F-3	3/4" Friction Ring
	5306056	F-3	1" Friction Ring
	5306057	F-3	1-1/4" Friction Ring
	5306058	F-3	1-1/2" Friction Ring
3.	*	F-2	3/4" CP Coupling
	*	F-2	3/4" RB Coupling
	*	F-2	1" CP Coupling
	*	F-2	1-1/4" CP Coupling
	*	F-2	1-1/4" RB Coupling
	0306045PK	F-2	1-1/2" CP Coupling
	*	F-2	1-1/2" RB Coupling
4.	5319086	S-30	1-1/2" Gasket
5.	0319079	S-21	1-1/2" Rigid Seat
3-5.	0306091	F-2-A	1-1/2" with S-21 Seat

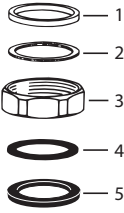

*N/A order appropriate F-2-A

NF-2-A

1.	0396264	F-105	1-1/2" x 1-1/4" SJ Gasket
1-3.	0314011	NF-2-A	1-1/2" x 1-1/4" SJ Reducing Coupling Assembly

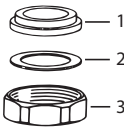

Spud Coupling Assemblies

Item No.	Code No.	Part No.	Description
F-5-A			
1-4.	0306125	F-5-A	3/4" CP Spud Coupling Assembly
	0306132	F-5-A	1" CP Spud Coupling Assembly
	0306140	F-5-A	1-1/4" CP Spud Coupling Assembly
	0306146	F-5-A	1-1/2" CP Spud Coupling Assembly
1-3.	0306516	F-20-AW	3/4" Spud Coupling
	0306524	F-20-AU	1-1/4" Spud Coupling
	0306526	F-20-AT	1-1/2" Spud Coupling
2.	5306055	F-3	3/4" Friction Ring
	5306056	F-3	1" Friction Ring
	5306057	F-3	1-1/4" Friction Ring
	5306058	F-3	1-1/2" Friction Ring
3.	5306113	F-5	3/4" SJ Gasket
	5306115	F-5	1" SJ Gasket
	5322176	VPF-5	1-1/4" Gasket
	5322001	VPF-5	1-1/2" Gasket
4.	0306189	F-7	3/4" Spud Flange
	0306197	F-7	1" Spud Flange
	0306214	F-7	1-1/4" Spud Flange
	0306238	F-7	1-1/2" Spud Flange

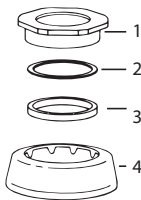

Note: 3-1/2" spud flange available in old style only.

The information contained in this document is subject to change without notice.

Wall Flange For Tubing

Code No.	Part No.	Description
F-7 (2-3/4" O.D. X 5/8" Deep)		
0306204	F-7	1-1/4" Tube Flange
0306237	F-7	1-1/2" Tube Flange



Supply Flange For Iron Pipe

Code No.	Part No.	Description
F-7 (2-3/4" O.D.)		
0306191	F-7	3/4" IPS CP Supply Flange
0306196	F-7	1" IPS CP Supply Flange
0306205	F-7	1-1/4" IPS CP Supply Flange



F-7 (2-3/4" O.D. Flat)

0306167	F-7	1/2" IPS CP Supply Flange
0306188	F-7	3/4" IPS CP Supply Flange
0306201	F-7	1" IPS CP Supply Flange
0306209	F-7	1-1/4" IPS CP Supply Flange



F-45-A

0396019	F-45-A	3/4" Heavy Supply Flange with Set Screw for IPS
0396020	F-45-A	1" Heavy Supply Flange with Set Screw for IPS



Outlets

Item No.	Code No.	Part No.	Description
F-1 (Flanged)			
1.	5319086	S-30	Gasket
2.	0306007	F-1	1-1/2" x 1-1/4" x 6" CP Flanged Outlet
	0306009	F-1	1-1/2" x 1-1/4" x 8" CP Flanged Outlet
	0306012	F-1	1-1/2" x 1-1/4" x 10" CP Flanged Outlet
	0306013	F-1	1-1/2" x 1-1/4" x 12" CP Flanged Outlet
	0306031	F-1	1-1/2" x 6" CP Flanged Outlet
	0306034	F-1	1-1/2" x 8" CP Flanged Outlet
	0306039	F-1	1-1/2" x 10" CP Flanged Outlet
	0306044	F-1	1-1/2" x 12" CP Flanged Outlet

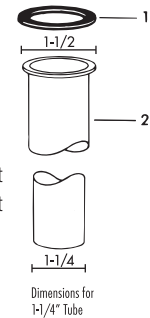

F-22

1.	5319086	S-30	Gasket
2.	0206159	F-22	1/2" IPS RB Female Outlet
	0206160	F-22	3/4" IPS RB Female Outlet
	0306569	F-22	1" IPS RB Female Outlet

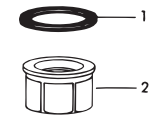

F-22-A

1-2.	0306574	F-22-A1-1/4" IPS RB Union Outlet Assembly	
	0306575	F-22-A1-1/4" IPS CP Union Outlet Assembly	
1.	5319086	S-30	Gasket

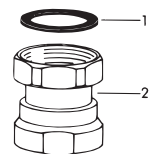

F-29-A

1.	5319086	S-30	Gasket
2.	0306767	F-29-A3/4" x 6" CP Outlet	
	0306769	F-29-A3/4" x 7-1/2" RB Outlet	
	0306773	F-29-A3/4" x 8-1/2" CP Outlet	
	0306791	F-29-A3/4" x 10-1/2" RB Outlet	

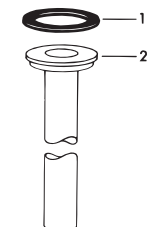

Flush Connections and Flanges

Outlets (continued)

Code No.	Part No.	Description
F-101		
0396060	F-101	3/4" x 4-1/2" CP Outlet
0396100	F-101	1-1/2" x 6" CP Outlet
0396113	F-101	1-1/2" x 9" CP Outlet
0396119	F-101	1-1/2" x 10-1/2" CP Outlet
0396127	F-101	1-1/2" x 13-1/2" CP Outlet
0396134	F-101	1-1/2" x 18-1/2" CP Outlet
0396142	F-101	1-1/2" x 21-1/2" CP Outlet
0396147	F-101	1-1/2" x 24-1/2" CP Outlet



F-102 (Scored - Both Ends)

0396175	F-102	1-1/4" x 5" RB Outlet, 3-3/4" "L" Dimension
0396176	F-102	1-1/4" x 6" RB Outlet, 4-3/4" "L" Dimension
0396177	F-102	1-1/4" x 7" RB Outlet, 5-3/4" "L" Dimension
0396178	F-102	1-1/4" x 8" RB Outlet, 6-3/4" "L" Dimension
0396179	F-102	1-1/4" x 9" RB Outlet, 7-3/4" "L" Dimension
0396180	F-102	1-1/4" x 10" RB Outlet, 8-3/4" "L" Dimension
0396181	F-102	1-1/4" x 11" RB Outlet, 9-3/4" "L" Dimension
0396182	F-102	1-1/4" x 12" RB Outlet, 10-3/4" "L" Dimension
0396183	F-102	1-1/4" x 13" RB Outlet, 11-3/4" "L" Dimension
0396184	F-102	1-1/4" x 14" RB Outlet, 12-3/4" "L" Dimension
0396185	F-102	1-1/4" x 15" RB Outlet, 13-3/4" "L" Dimension
0396186	F-102	1-1/4" x 16" RB Outlet, 14-3/4" "L" Dimension
0396678	F-102	1-1/2" x 5" RB Outlet, 3-3/4" "L" Dimension
0396674	F-102	1-1/2" x 6" RB Outlet, 4-3/4" "L" Dimension
0396194	F-102	1-1/2" x 7" RB Outlet, 5-3/4" "L" Dimension
0396201	F-102	1-1/2" x 8" RB Outlet, 6-3/4" "L" Dimension
0396206	F-102	1-1/2" x 9" RB Outlet, 7-3/4" "L" Dimension
0396210	F-102	1-1/2" x 10" RB Outlet, 8-3/4" "L" Dimension
0396214	F-102	1-1/2" x 11" RB Outlet, 9-3/4" "L" Dimension
0396217	F-102	1-1/2" x 12" RB Outlet, 10-3/4" "L" Dimension
0396220	F-102	1-1/2" x 13" RB Outlet, 11-3/4" "L" Dimension
0396221	F-102	1-1/2" x 14" RB Outlet, 12-3/4" "L" Dimension
0396224	F-102	1-1/2" x 15" RB Outlet, 13-3/4" "L" Dimension
0396715	F-102	1-1/2" x 16" RB Outlet, 14-3/4" "L" Dimension



Outlets (continued)

Code No.	Part No.	Description
Special F-102 (Scored - One End)		
0396163	F-102	1-1/4" x 8" CP Outlet, 3-3/4" "L" Dimension
0396164	F-102	1-1/4" x 9" CP Outlet, 4-3/4" "L" Dimension
0396171	F-102	1-1/4" x 15" CP Outlet, 10-3/4" "L" Dimension
0396669	F-102	1-1/2" x 8" CP Outlet, 3-3/4" "L" Dimension
0396670	F-102	1-1/2" x 9" CP Outlet, 4-3/4" "L" Dimension
0396671	F-102	1-1/2" x 10" CP Outlet, 5-3/4" "L" Dimension
0396679	F-102	1-1/2" x 11" CP Outlet, 6-3/4" "L" Dimension
0396672	F-102	1-1/2" x 12" CP Outlet, 7-3/4" "L" Dimension
0396673	F-102	1-1/2" x 13" CP Outlet, 8-3/4" "L" Dimension
0396713	F-102	1-1/2" x 14" CP Outlet, 9-3/4" "L" Dimension
0396714	F-102	1-1/2" x 15" CP Outlet, 10-3/4" "L" Dimension
0396716	F-102	1-1/2" x 16" CP Outlet, 11-3/4" "L" Dimension

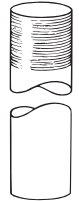

F-201

0396455	F-201	1-1/2" x 1-1/4" x 9" CP Outlet
0396456PK	F-201	1-1/2" x 1-1/4" x 11" CP Outlet
0396461	F-201	1-1/2" x 1-1/4" x 11" CP Outlet
0396464	F-201	1-1/2" x 1-1/4" x 21-1/2" CP Outlet
0396468PK	F-201	1-1/2" x 1-1/4" x 10" CP Outlet



Offset Outlet Tubes

0396202	F-66-A	3/4" x 1" Offset x 13-1/4"
0396203	F-67-A	3/4" x 1-1/2" Offset x 13-1/4"
0396204	F-68-A	3/4" x 2" Offset x 13-1/4"
0396530	F-188	1-1/2" x 1" Offset x 13-1/4"
0396532PK	F-189	1-1/2" x 1-1/2" Offset x 13-1/4"
0396534	F-190	1-1/2" x 2" Offset x 13-1/4"

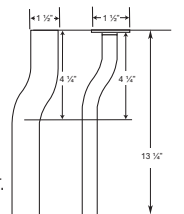

Designed for use with V-600-A or V-500-A "short" Vacuum Breaker. Each tube is 13-1/4" in length.

For 3/4" tubes, and "short" Vacuum Breaker, use F-2-A Coupling S-30 Gasket (Code No. **0306092**).

For 1-1/2" tubes, and "short" Vacuum Breaker, use F-2-A Coupling with Slip Gasket (Code No. **0306093**)

F-31-AA (For High Clearance Offset and Rigid Application)

0306919	F-31-AA	1-1/2" x 8-1/4" CP Flanged and Coupling Outlet ASM W/1" Offset
0306921	F-31-AA	1-1/2" x 8-1/4" CP Flanged and Coupling Outlet ASM W/2" Offset
0306922	F-31-AA	1-1/2" x 9-3/4" CP Flanged and Coupling Outlet ASM W/2" Offset

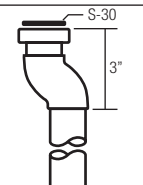

F-182 Flanged Outlet Tube w/Offset

0396525	F-182	1-1/2" x 8" x 1-1/2" Offset
---------	-------	-----------------------------

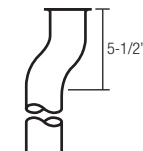

Flush Connections and Flanges

Elbows

Code No.	Part No.	Description
F-15-A		
0306341	F-15-A	3/4" CP SJ Ell with Tail 4-5/8" C to E
0306472	F-15-A	1-1/4" CP SJ Ell with Tail 4-5/8" C to E
0306340	F-15-A	3/4" RB SJ Ell & Tail F/ 3-3/4" L Dimension
0306344	F-15-A	3/4" RB SJ Ell & Tail F/ 5-3/4" L Dimension
0306350	F-15-A	3/4" RB SJ Ell & Tail F/ 6-3/4" L Dimension
0306355	F-15-A	3/4" RB SJ Ell & Tail F/ 7-3/4" L Dimension
0306358	F-15-A	3/4" RB SJ Ell & Tail F/ 8-3/4" L Dimension
0306362	F-15-A	3/4" RB SJ Ell & Tail F/ 9-3/4" L Dimension
0306366	F-15-A	3/4" RB SJ Ell & Tail F/ 10-3/4" L Dimension

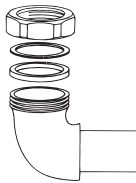

F-21-AA

0306555	F-21-AA	1-1/2" x 1-1/4" CP Ell with Tail 5 C to E
0306558	F-21-AA	1-1/2" x 1-1/4" CP Ell with Tail 8 C to E

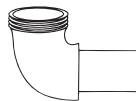

F-25-A

0306671	F-25-A	1-1/2" RB SJ Ell with Tail 4-3/4" C to E W/2" Score
0306678	F-25-A	1-1/2" RB SJ Ell with Tail 5-1/2" C to E
0306682	F-25-A	1-1/2" RB SJ Ell with Tail 8" C to E W/2" Score
0306683	F-25-A	1-1/2" RB SJ Ell with Tail 8" C to E W/4" Score
0306687	F-25-A	1-1/2" RB SJ Ell with Tail 9" C to E
0306688	F-25-A	1-1/2" RB SJ Ell with Tail 10" C to E W/3 Score
0306712	F-25-A	1-1/2" RB SJ Ell with Tail 14" C to E W/3 Score
0306737	F-25-A	1-1/2" RB SJ Ell with Tail 19" C to E W/3 Score
0306719	F-25-A	1-1/2" RB SJ Ell with Tail 21" C to E W/3 Score

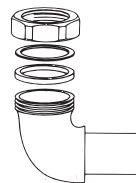

F-43-A

0396009	F-43-A	1" CP Outlet A7 Street Ell (Royal®)
0396010	F-43-A	1" CP Outlet A7 Street Ell (Crown®)

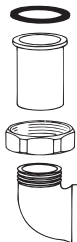

Tube Ends

Code No.	Part No.	Description
F-109		
0396265	F-109	1-1/4" x 5" x 8-1/2" CP Tube Bend
0396283	F-109	1-1/4" x 5" x 11-1/2" CP Tube Bend
0396288	F-109	1-1/4" x 5" x 13-1/2" CP Tube Bend
0396289	F-109	1-1/4" x 5" x 16" CP Tube Bend
0396290	F-109	1-1/4" x 5" x 21" CP Tube Bend
0396291	F-109	1-1/4" x 5" x 24" CP Tube Bend
0396293	F-109	1-1/2" x 5" x 8-1/2" CP Tube Bend
0396310	F-109	1-1/2" x 5" x 11-1/2" CP Tube Bend
0396316	F-109	1-1/2" x 5" x 13-1/2" CP Tube Bend
0396320	F-109	1-1/2" x 5" x 16" CP Tube Bend
0396322	F-109	1-1/2" x 5" x 21" CP Tube Bend
0396326	F-109	1-1/2" x 5" x 24" CP Tube Bend

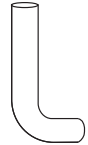

Miscellaneous

V-75

0322013	V-75	Inlet Adaptor for old style Royal®
0322015	V-75	Inlet Adaptor for old style Crown®



Special V-79

0322021	Spl V-79	3/4" RB Inlet Adaptor
0322026	Spl V-79	1" RB Inlet Adaptor



Offset Vacuum Breaker Outlet Tubes

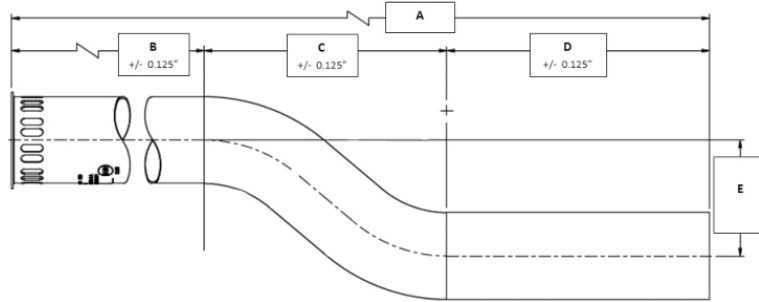

Part no.	Code no	Description	Vacuum Breaker Length A	Offset E	Approx. Length Above Offset B	Approx. Length of Offset C	Approx. Length After Offset D
V-600AA V500AA	0393029 0323229	1½" x 22½" x 2" Offset	1½" x 22½"	2"	13 ¼"	4 ½"	4 ¾"
V-600AA V500AA	0393025 0323225	1½" x 22 13/16" x 1" Offset	1½" x 22 13/16"	1"	13 ¼"	4 ¼"	5 ¼"
V-600AA V500AA	0393027 0323227	1½" x 22 5/8" x 1½" Offset	1½" x 22 5/8"	1½"	13 ¼"	4 ½"	5 ½"
V-600AA V500AA	0393030 0323230	1½" x 25½" x 2" Offset	1½" x 25½"	2"	16 ¼"	4 ½"	4 ¾"
V-600AA V500AA	0393026 0323226	1½" x 25 13/16" x 1" Offset	1½" x 25 13/16"	1"	16 ¼"	4 ¼"	5 ¼"
V-600AA V500AA	0393028 0323228	1½" x 25 5/8" x 1½" Offset	1½" x 25 5/8"	1½"	16 ¼"	4 ½"	5 ½"

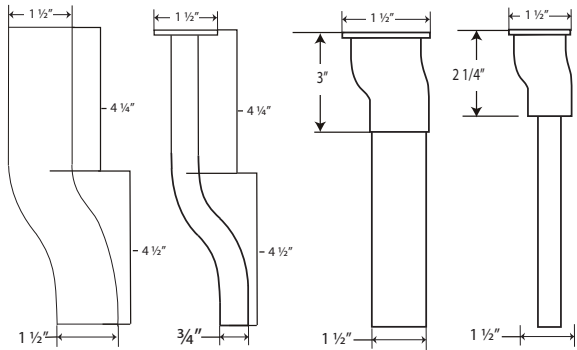
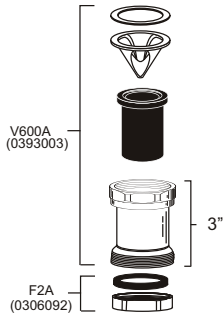

F188
F-189
F-190

F66A
F67A
F68A

F31AA

F29A

Part no.	Dimensions	Code no
F188	1½" x 13¼" x 1" Offset	0396530PK
F189	1½" x 13¼" x 1½" Offset	0396532PK
F190	1½" x 13¼" x 2" Offset	0396534PK
Part no.	Dimensions	Code no
F66A	1½" x 13¼" x 1" Offset	0396530
F67A	1½" x 13¼" x 1½" Offset	0396203
F68A	1½" x 13¼" x 2" Offset	0396204
Part no.	Dimensions	Code no
F31AA	1½" x 8 ¼" x 1" Offset	0306919
F31AA	1½" x 8 ¼" x 2" Offset	0306921
F31AA	1½" x 9 ¾" x 1½" Offset	0306922
Part no.	Dimensions	Code no
F29A	¾" x 7" x ½" Offset	0306787
F29A	¾" x 6" x 1" Offset	0306851
F29A	¾" x 13¼" x ½" Offset	0306762

Bumpers, Pipe, and Tube Supports



BUMPERS

Item No.	Code No.	Part No.	Description
----------	----------	----------	-------------

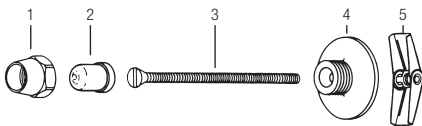

1-5	0310001	J-1-A	Flat Wall Bumper CP - Complete
1-2	5310034	J-2/J-7	Ferrule with White Plastic Bumper

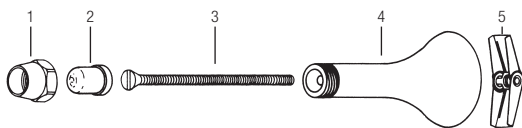

1-5	0310004	J-5-A	Wall Bumper Extension CP - Complete
1-2	5310034	J-2/J-7	Ferrule with White Plastic Bumper

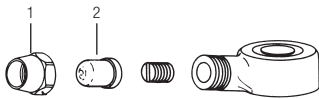

	0310018	J-9-A	Cover Bumper for Old Style Royal – OBSOLETE
1-2	5310034	J-2/J-7	Ferrule with White Plastic Bumper

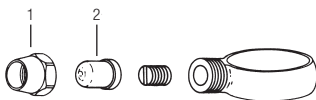

	0310038	J-12-A	1-1/2" Pipe Strap Bumper CP – OBSOLETE
1-2	5310034	J-2/J-7	Ferrule with White Plastic Bumper

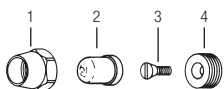

1-4	0310045	J-13-A	Wheel Handle Angle Stop Bumper CP - Complete
1-2	5310034	J-2/J-7	Ferrule with White Plastic Bumper

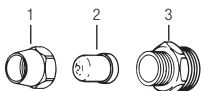

1-3	0310054	J-18-A	Old Style Screw Driver Stop Bumper CP - Complete
1-2	5310034	J-2/J-7	Ferrule with White Plastic Bumper
3	0310052	J-18	CP Lock Shield

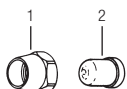

1-2	5310034	J-2/J-7	Ferrule with White Plastic Bumper
1	0310016PK	J-7	CP Ferrule for Plastic Bumper
2	5310003	J-2	White Plastic Bumper

PIPE AND TUBE SUPPORTS

Item No.	Code No.	Part No.	Description
----------	----------	----------	-------------

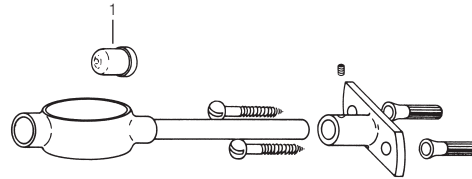

	0310081	J-112-A	1-1/2" Tube Support with Bumper 5 C/E - Complete
1	0310003	J-2	White Plastic Bumper

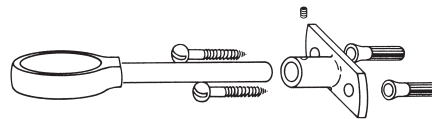

	0310083	J-212-A	1-1/2" Solid Ring Tube Support CP 5 C/E – Complete
	0310087	J-212-A	1-1/2" Solid Ring Tube Support CP 6 C/E – Complete
	0310097	J-212-A	CP Pipe Support 1" IPS 5 C/E – For Iron Supply Pipe

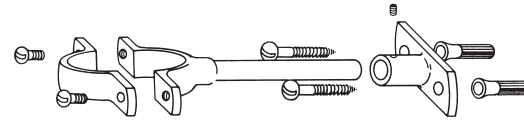

	0310090	J-312-A	1-1/2" Split Ring Tube Support CP 5 C/E – Complete
	0310092	J-312-A	1-1/2" Split Ring Tube Pipe Support CP 6 C/E – Complete
	0310095	J-312-AV	1" Split Ring Pipe Support CP 5 C/E – Complete – For Iron Supply Pipe

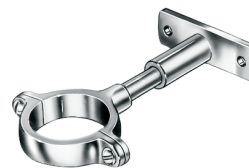

Split Ring Pipe Support J-312-A



Solid Ring Pipe Support J-212-A



Solid Ring Pipe Support with Seat Bumper J-112-A

Floor Valves

1/2" FLOOR VALVE

Item			
No.	Code No.	Part No.	Description
	3316042	P-1000-A	1/2" Floor Valve Repair Kit (Includes Packing, Cotter Pin, Gasket, Leather Cup and Seats – DISCONTINUED)

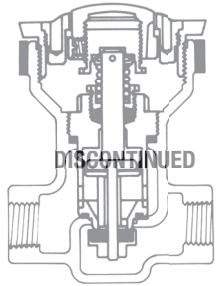

1/2 inch Floor Valve



Sweat Solder Kits

SWEAT SOLDER KITS

Item			
No.	Code No.	Part No.	Description
H-533-A			
1	3308603	H-532	1" Adapter*
1, 2, 5	3308780	H-533-AS	Sweat Solder Kit W/Stamped Wall Flange for 1" Supply-Closet & Urinal
1-4	3308794	H-533-AC	Sweat Solder Kit W/Cast Wall Flange for 1" Supply-Closet & Urinal
2.		H-534	1 3/8" Casing Tube for 1" Copper
	0308605PK	H-534	1 3/8" x 3" Casing Tube for 1" Copper
	0308606PK	H-534	1 3/8" x 6" Casing Tube for 1" Copper
	0308593PK	H-534	1 3/8" x 22-1/4" Casing Tube for 1" Copper
	0308587PK	H-534	1 3/8" x 36" Casing Tube for 1" Copper
H-534-A			
1	3308603	H-532	1" Adapter*
1, 2, 5	3308783	H-534-AS	Sweat Solder Kit W/Stamped Wall Flange for 1" Supply-Closet & Urinal 3" Tube
1-4	3308796	H-534-AC	Sweat Solder Kit W/Cast Wall Flange for 1" Supply-Closet & Urinal
2	—	H-534	Casing Tube for 1" Copper
H-536-A			
1	3308607	H-535-A	3/4" Adapter*
1, 2, 5	3308786	H-536-AS	Sweat Solder Kit W/Stamped Wall Flange for 3/4" Supply-Closet & Urinal
1-4	3308798	H-536-AC	Sweat Solder Kit W/Cast Wall Flange for 3/4" Supply-Closet & Urinal
2	—	H-537	1 1/8" Casing Tube for 3/4" Copper

Note: H-532-AS, H-533-AS, H-534-AS, H-535-AS and H-536-AS are also identified as suffix YB when furnished with flush valve.

All Tube lengths- 2"

*Furnished separate for concealed installations.

Item			
No.	Code No.	Part No.	Description
H-633-AA			
1	3308603	H-532	1" Adapter
1-4	3308782	H-633-AA	Sweat Solder Kit for 1" Supply – Urinal 3" Tube
2	—	H-534	Casing Tube for 1" Copper
H-634-AA			
1	3308603	H-532	1" Adapter
1-4	3308785	H-634-AA	Sweat Solder Kit for 1" Supply – Closet 6" Tube
2	—	H-534	Casing Tube for 1" Copper
H-636-AA			
1	0308607	H-535	3/4" Adapter
1-4	3308788	H-636-AA	Sweat Solder Kit for 3/4" Supply – Urinal
2	—	H-537	Casing Tube for 3/4" Copper

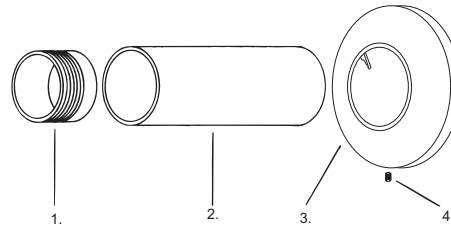
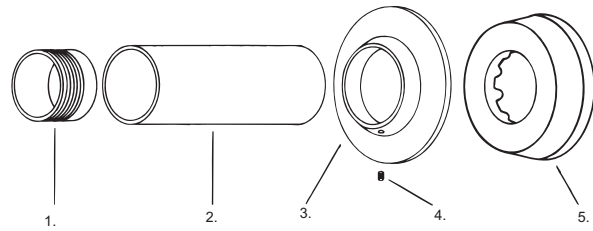

Flushometer Parts Quick Reference Guide

V-500-AA VACUUM BREAKER FLUSH CONNECTION

Code No.	Part No.	Description
5323006	V-500-AA	CP Vacuum Breaker 1-1/4" x 9"
5323005	V-500-AA	CP Vacuum Breaker 3/4" x 9"
5323007	V-500-AA	CP Vacuum Breaker 1-1/2" x 9"
0323229	V-500-AA	CP Vacuum Breaker 1-1/2" x 22-1/2" w/2" Offset
0323225	V-500-AA	CP Vacuum Breaker 1-1/2" x 22-13/16" w/1" Offset
0323227	V-500-AA	CP Vacuum Breaker 1-1/2" x 22-5/8" w/1-1/2" Offset
0323230	V-500-AA	CP Vacuum Breaker 1-1/2" x 25-1/2" w/2" Offset
0323226	V-500-AA	CP Vacuum Breaker 1-1/2" x 25-13/16" w/1" Offset
0323228	V-500-AA	CP Vacuum Breaker 1-1/2" x 25-5/8" w/1-1/2" Offset
0323013	V-500-AA	CP Vacuum Breaker 1-1/2" x 10-1/2"
0323014	V-500-AA	CP Vacuum Breaker 1-1/2" x 13-1/2"
0323017	V-500-AA	CP Vacuum Breaker 1-1/2" x 15"
0323015	V-500-AA	CP Vacuum Breaker 1-1/2" x 21-1/2"
0323016	V-500-AA	CP Vacuum Breaker 1-1/2" x 24-1/2"
0323021	V-500-AA	CP Vacuum Breaker 1-1/2" x 26"
0323057	V-500-AA	CP Vacuum Breaker 1-1/2" x 32"
0323002	V-500-AA	CP Vacuum Breaker 1-1/4" x 10-1/2"
0323018	V-500-AA	CP Vacuum Breaker 1-1/4" x 13-1/2"
0323026	V-500-AA	CP Vacuum Breaker 1-1/4" x 15"
0323020	V-500-AA	CP Vacuum Breaker 1-1/4" x 21-1/2"
0323012	V-500-AA	CP Vacuum Breaker 1" x 9"
0323004	V-500-AA	CP Vacuum Breaker 3/4" x 10-1/2"
0323210	V-500-AA	CP Vacuum Breaker 3/4" x 15"
0323188	V-500-AA	RB Vacuum Breaker 1-1/2" x 11-1/2" w/3" Score
0323142	V-500-AA	RB Vacuum Breaker 1-1/2" x 13-1/2" w/3" Score
0323176	V-500-AA	RB Vacuum Breaker 1-1/2" x 17-1/2" w/3" Score
0323177	V-500-AA	RB Vacuum Breaker 1-1/2" x 22" w/3" Score
0323209	V-500-AA	RB Vacuum Breaker 1-1/2" x 30-1/2" w/3" Score
0323207	V-500-AA	RB Vacuum Breaker 1-1/2" x 6" w/3" Score
0323208	V-500-AA	RB Vacuum Breaker 1-1/2" x 7-1/2" w/3" Score

V-600-AA VACUUM BREAKER FLUSH CONNECTION

Code No.	Part No.	Description
0393029	V-600-AA	CP Vacuum Breaker 1-1/2" x 22-1/2" w/2" Offset
0393025	V-600-AA	CP Vacuum Breaker 1-1/2" x 22-13/16" w/1" Offset
0393027	V-600-AA	CP Vacuum Breaker 1-1/2" x 22-5/8" w/1-1/2" Offset
0393030	V-600-AA	CP Vacuum Breaker 1-1/2" x 25-1/2" w/2" Offset
0393026	V-600-AA	CP Vacuum Breaker 1-1/2" x 25-13/16" w/1" Offset
0393028	V-600-AA	CP Vacuum Breaker 1-1/2" x 25-5/8" w/1-1/2" Offset
0393008	V-600-AA	CP Vacuum Breaker 1-1/2" x 13-1/2"
0393031	V-600-AA	CP Vacuum Breaker 1-1/2" x 15"
0393009	V-600-AA	CP Vacuum Breaker 1-1/2" x 21-1/2"
0393010	V-600-AA	CP Vacuum Breaker 1-1/2" x 24-1/2"
0393038	V-600-AA	CP Vacuum Breaker 1-1/2" x 36"
3393007	V-600-AA	CP Vacuum Breaker 1-1/2" x 9" package
0393039	V-600-AA	CP Vacuum Breaker 1-1/4" x 13-1/2"
0393045	V-600-AA	CP Vacuum Breaker 1-1/4" x 21-1/2"
3393006	V-600-AA	CP Vacuum Breaker 1-1/4" x 9" package
0393046	V-600-AA	CP Vacuum Breaker 3/4" x 10-1/2"
0393047	V-600-AA	CP Vacuum Breaker 3/4" x 15"
3393004	V-600-AA	CP Vacuum Breaker 3/4" x 9" package

F-7 SUPPLY FLANGE

0306167	F-7	CP Flange Flat 1/2" IPS x 2-23/32"
0306188	F-7	CP Flange Flat 3/4" x 2-23/32"
0306238	F-7	CP Flange Spud 1-1/2" x 3" w/Prongs
0306214	F-7	CP Flange Spud 1-1/4" x 3" w/Prongs
0306197	F-7	CP Flange Spud 1" x 2-1/2" w/Prongs
0306189	F-7	CP Flange Spud 3/4" x 2-1/2" w/Prongs
0306205	F-7	CP Flange Supply 1-1/4" x 3"
0306196	F-7	CP Flange Supply 1" x 2-3/4" w/Prongs
0306191	F-7	CP Flange Supply 3/4" x 2-3/4" w/Prongs
0306209	F-7	CP Flange Supply Flat 1-1/4" x 3-1/8"
0306201	F-7	CP Flange Supply Flat 1" x 3-1/8"
0306204	F-7	CP Flange Tube 1-1/4" x 2-3/4" w/Prongs
0306237	F-7	CP Flange Tube 1-1/2" x 2-3/4" w/Prongs

F-15-A ELBOW FLUSH CONNECTION

0306341	F-15-A	CP Elbow Tail Assembly SJ 3/4" x 4"
0306362	F-15-A	RB Elbow Tail Assembly SJ 3/4" x 10"
0306366	F-15-A	RB Elbow Tail Assembly SJ 3/4" x 11"
0306340	F-15-A	RB Elbow Tail Assembly SJ 3/4" x 4"
0306344	F-15-A	RB Elbow Tail Assembly SJ 3/4" x 6"
0306350	F-15-A	RB Elbow Tail Assembly SJ 3/4" x 7"
0306355	F-15-A	RB Elbow Tail Assembly SJ 3/4" x 8"
0306358	F-15-A	RB Elbow Tail Assembly SJ 3/4" x 9"

F-109 TUBE BEND

Code No.	Part No.	Description
0396310	F-109	CP Tube Outlet 1-1/2" x 11-1/2" x 5" Bends
0396283	F-109	CP Tube Outlet 1-1/4" x 11-1/2" x 5" Bends
0396288	F-109	CP Tube Outlet 1-1/4" x 13-1/2" x 5" Bends
0396293	F-109	CP Tube Outlet 1-1/2" x 8-1/2" x 5" Bends
0396265	F-109	CP Tube Outlet 1-1/4" x 8-1/2" x 5" Bends
0396316	F-109	CP Tube Outlet 1-1/2" x 13" x 5" Bends
0396320	F-109	CP Tube Outlet 1-1/2" x 16" x 5" Bends
0396322	F-109	CP Tube Outlet 1-1/2" x 21" x 5" Bends
0396326	F-109	CP Tube Outlet 1-1/2" x 24" x 5" Bends
0396289	F-109	CP Tube Outlet 1-1/4" x 16" x 5" Bends
0396290	F-109	CP Tube Outlet 1-1/4" x 21" x 5" Bends
0396291	F-109	CP Tube Outlet 1-1/4" x 24" x 5" Bends

F-100 FLARED END FLUSH CONNECTION

Code No.	Part No.	Description
0396160	F-100	RB Outlet 1-1/2" x 11-1/2" w/3" Score
0396167	F-100	RB Outlet 1-1/2" x 13-1/2" w/3" Score
0396168	F-100	RB Outlet 1-1/2" x 19-1/2" w/3" Score
0396169	F-100	RB Outlet 1-1/2" x 23-1/2" w/3" Score
0396156	F-100	RB Outlet 1-1/2" x 3-1/4" w/3" Score
0396157	F-100	RB Outlet 1-1/2" x 5-1/2" w/3" Score
0396158	F-100	RB Outlet 1-1/2" x 7-1/2" w/3" Score
0396159	F-100	RB Outlet 1-1/2" x 9-1/2" w/3" Score
0396161	F-100	RB Outlet 1-1/2" x 9-1/2" w/9" Score

BASYS® Faucet Infrared Sensor Activated

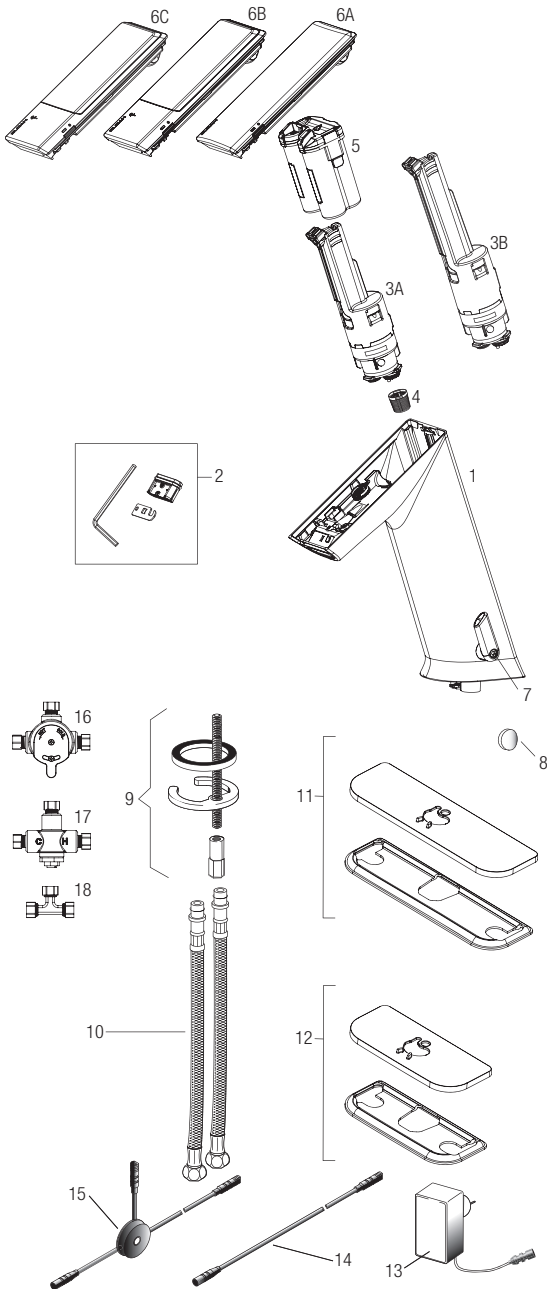

PARTS LIST—BASYS FAUCETS

Item No.	Code No.	Part No.	Description
1.	—	—	Mid Mount Faucet Assembly
	—	—	Mid Mount Faucet Assembly with Mixer
	—	—	High Mount Faucet Assembly
	—	—	High Mount Faucet Assembly with Mixer
2.	3324104	EFX-1002-A	0.5 gpm/1.9 Lpm Multi-Lam Insert (includes insert, o-ring, 2.5 mm allen key and removal tool)
	3324103	EFX-1001-A	1.5 gpm/5.7 Lpm Aerated Stream Insert (includes insert, o-ring, 2.5 mm allen key and removal tool)
	3324102	EFX-1000-A	1.5 gpm/5.7 Lpm Laminar Stream Insert (includes insert, o-ring, 2.5 mm allen key and removal tool)
3A.	3324122	EFX-15-A	0.5 gpm/1.9 Lpm Solenoid Valve Caddy Assembly – Mid Mount (Green)
	3324123	EFX-16-A	1.5 gpm/5.7 Lpm Solenoid Valve Caddy Assembly – Mid Mount (Blue)
3B.	3324124	EFX-17-A	0.5 gpm/1.9 Lpm Solenoid Valve Caddy Assembly – High Mount (Green)
	3324125	EFX-18-A	1.5 gpm/5.7 Lpm Solenoid Valve Caddy Assembly – High Mount (Blue)
4.	0324019	EFX-19	Strainer (Filter)
5.	3324128	EFX-7-A	Battery Pack Assembly (includes 4 "AA" batteries)
6A.	3324118	EFX-1-A	Crown Assembly
6B.	3324119	EFX-3-A	Solar Crown Assembly
6C.	3324120	EFX-4-A	Solar Crown with LCD Assembly
7.	3324133	EFX-24-A	Mixer Handle Assembly
8.	3324134	EFX-25A	Handle Cap Kit (bag of 5)
9.	0335000	EAJ-1	Faucet Mounting Kit (Pedestal)
10.	3335023	EAJ-1008	13" (330 mm) Flexible Supply Hose (1)
11.	3324101	EFX-26-A	Trim Plate for 8" Centerset Sink
12.	3324100	EFX-20-A	Trim Plate for 4" Centerset Sink
13.	0335009	EAJ-11	Plug-in Voltage Adapter (US)
	0335041	EAJ-41	Plug-in Voltage Adapter (EU)
	0335039	EAJ-39	Plug-in Voltage Adapter (UK)
	0335037	EAJ-37	Box Type Voltage Adapter
14.	0335024	EAJ-24-A	11-13/16" (300 mm) Extension Cable
	0335025	EAJ-25-A	47-1/4" (1200 mm) Extension Cable
	0335015	EAJ-17-A	126" (3200 mm) Extension Cable
15.	0335023	EAJ-23-A	Splitter
16.	3326009	MIX-60-A	Mechanical, Below Deck Mixing Valve
17.	0326045	MIX-135-A	Thermostatic, Below Deck Mixing Valve
18.	3365461	ETF-617-A	Bak-Chek Tee

NOTE: If changing flow rate caddy and spray insert must be changed in conjunction.
 — in Item No. column = Not shown in illustration
 — in Code No. and Part No. column = Not sold separately

Electrical Connection for up to Six (6) Faucets Using One (1) Adapter

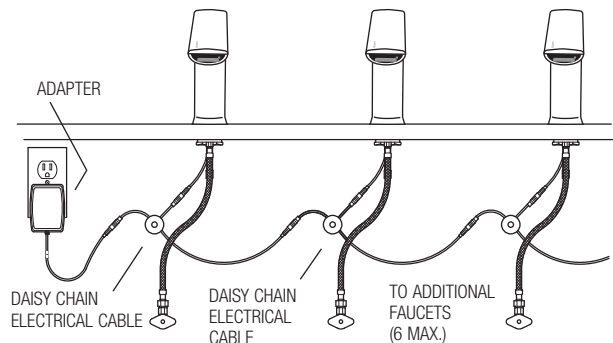

BASYS® Faucet Infrared Sensor Activated

OPERATION

As the user's hands enter the beam's effective range, the beam is reflected back into the sensor receiver and activates the solenoid valve allowing water to flow from the faucet. Water will flow until the hands are removed or until the faucet reaches its automatic time out limit setting.

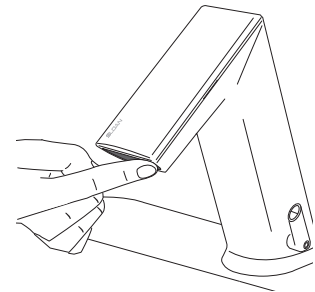
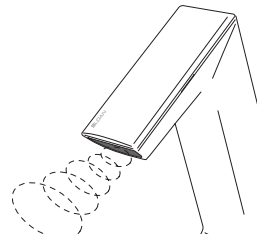

SET AND FIX TEMPERATURE AND ADJUST HOT LIMIT STOP

Adjust lever to set temperature.

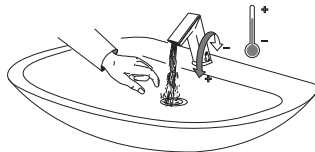

Optional — To fix temperature, set lever to the desired position, then remove lever and plug hole with Cap.

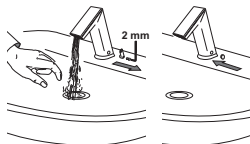

Optional Hot Limit Stop Adjustment — To adjust the hot/cold mix (factory set at 50/50) remove the lever.

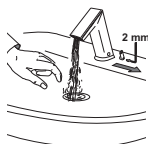

Check to make sure dot is in center position before beginning adjustment.

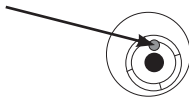

Faucet may be adjusted in 10° increments.

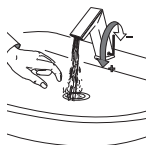

Function	Steps to Activate Function	Default Setting	IR Clic
IR Activation	Cover IR clic approximately for 2 sec. until LED will flash GREEN 1x - then remove finger from IR clic (Active for 5 sec.)	—	—
Cleaning Mode	IR activation; Cover IR clic 2x - confirmation of the function is active by a couple flashes by the LED; to return to normal operation cover IR clic 1x or the faucet will automatically return to normal function after 2 min.	2 min.	—
12/24 Line Purge Feature	See below.	Off	Off 12HR 24HR
Sensor Range Adjustment	See page 152.	6	1-8
Reset Electronics	IR activation; Cover IR clic 2x; LED will flash 5x Cover IR clic 1x for 5 sec. until LED flashes 4x, then remove finger from IR clic Wait for 20 sec. (After 10 sec. water will flow for 6 sec. and automatically adjust to environment)	Manually	—
Security Off	After 90 seconds (max) of hand and/or object within sensor appears permanent, waterflow will stop and will remeasure environment	On	—

Please contact factory for more extensive programming options.

12/24 LINE PURGE FEATURE

This feature will operate the faucet every 12 or 24 hours since last use, if not used to prevent stagnant water conditions.

Default purge duration is two minutes.

Consult factory regarding other timing options.

IR activation (see above). Cover IR clic approximately 24 sec. (ignore LED indications during this period). Release when requested program is reached. (See diagram to right). Programming mode will time out after 2 minutes if no changes are made.

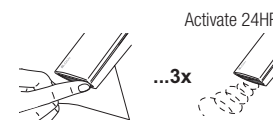
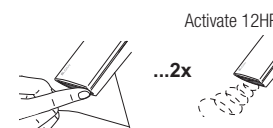
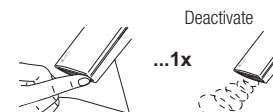
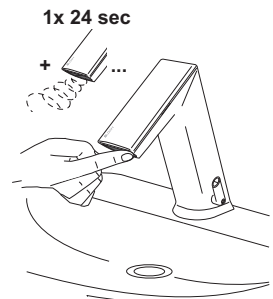

BASYS® Faucet Infrared Sensor Activated

SENSOR RANGE ADJUSTMENT

Factory setting is appropriate for the majority of applications and should not require resetting unless under extreme situations.

IR Activation (see previous page). To enter programming mode place finger on IR clic 2 times then remove. Light on side of crown should blink to indicate programming mode.

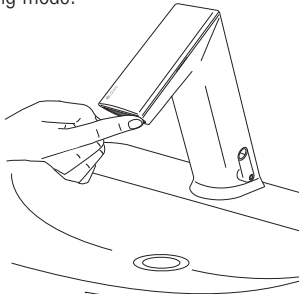

Cover IR clic until LED flashes 4x - hold until LED flashes 1x to 8x, from minimum to maximum. See diagram below. Release when requested range is reached.

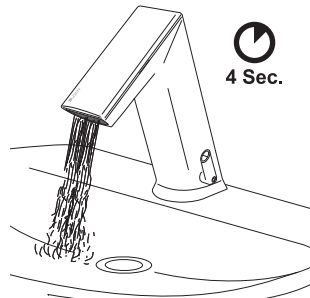
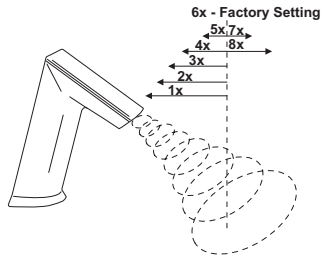

Wait, until LED flashes GREEN.

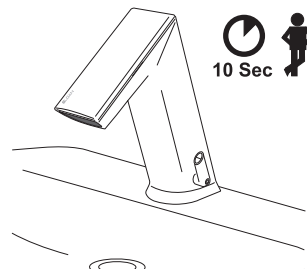

BATTERY REPLACEMENT

NOTE: Replace Battery when LED1 indicator flashes red each time faucet is in use or when faucet stops functioning. LED1 is identified by the battery symbol.

NOTE: Turning off water is not necessary.

Remove crown by loosening hex screw located on underside of spout and slide crown down and lift off.

NOTE: Screw is captive within faucet body and will not fall out.

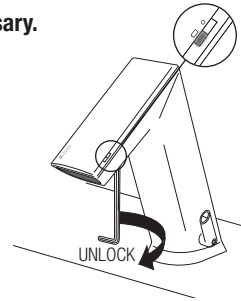

Remove battery pack assembly by lifting out of spout.

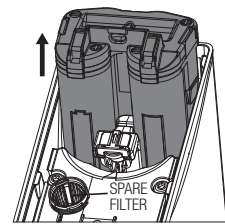

Open battery pack assembly by pushing in tabs on side of assembly.

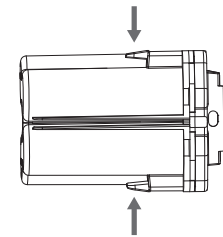

Remove (4) AA-cell batteries from battery pack.

Insert four (4) NEW AA-cell batteries into battery pack assembly cartridge.

NOTE: Insure batteries are installed with proper polarity. The cover of the case indicates polarity of batteries. Improper polarity will not harm the faucet. Improper polarity will cause the faucet not to operate.

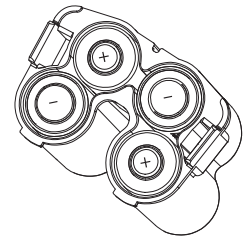

Replace cover of the battery pack assembly and reinsert assembly into faucet.

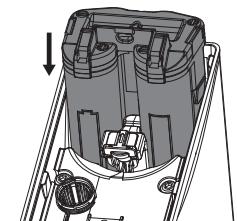

Slide on crown and secure.

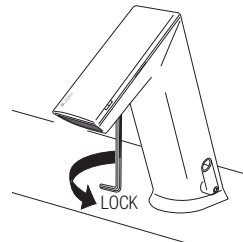

BASYS® Faucet Infrared Sensor Activated

REPLACE SPRAY INSERT

NOTE: Turning off water is not necessary, due to integrated automatic stop valve.

Remove crown by loosening hex screw located on underside of spout and slide crown down and lift off.

NOTE: Screw is captive within faucet body and will NOT fall out.

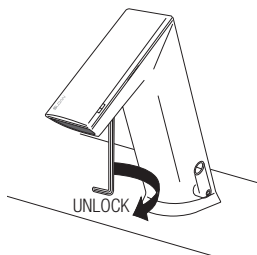

Retrieve spray removal tool located near the spray insert.

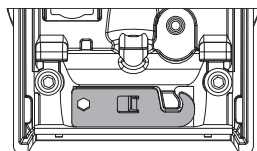

Insert spray removal tool into spray slot by sliding hook end of key between faucet spout and insert. Pull insert out of faucet once hooked.

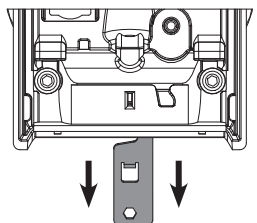

Install new insert.

NOTE: If changing to a different flow rate solenoid caddy must be changed in conjunction.

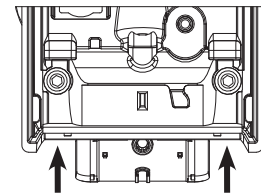

Return spray removal tool to storage location.

NOTE: This can only be done once spray head is installed. This will lock the spray head in place.

NOTE: If spray head is inserted incorrectly – key will not lock in properly. Turn faucet on to push insert out and re-install.

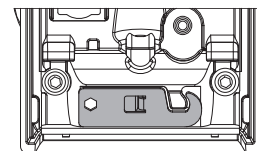

Slide on crown and secure.

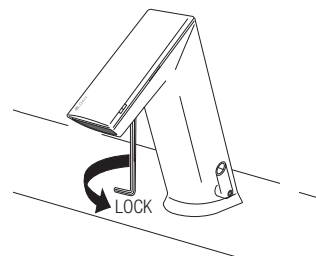

BASYS® Faucet Infrared Sensor Activated

TROUBLESHOOTING GUIDE

1. Red LED in spout does not blink 2 sec after battery installation.

- Battery placement incorrect or batteries have been discharged.
- Ensure batteries are installed properly. Check the orientation of each battery matches the positive (+) and negative (-) symbols shown on the battery compartment.

2. Faucet DOES NOT function.

- Adhesive packaging label affixed over sensor eye.
- Remove adhesive label from sensor eye.

3. Faucet delivers water in an uncontrolled manner.

- Clean sensor window. If continually not working contact Sloan Tech Support.

4. Faucet DOES NOT deliver any water when sensor is activated.

- INDICATOR: Solenoid valve produces an audible "CLICK".
- Water supply stop(s) closed.
Open water supply stop(s).
 - Strainer is clogged.
Remove, clean, and reinstall strainer. Replace strainer, if needed (refer to page 157).
- INDICATOR: Solenoid valve DOES NOT produce an audible "CLICK".
- Batteries low (battery-powered models).
Replace batteries (refer to battery replacement on page 157).
 - Power failure (hardwire models).
Check power supply.

5. Faucet delivers only a slow flow or dribble when sensor is activated.

- Water supply stop(s) are partially closed.
Completely open water supply stop(s).

6. Faucet DOES NOT stop delivering water or continues to drip after user is no longer detected.

- Clean sensor window. If continually not working contact Sloan's Technical Support (see below).

7. LED indicator blinks RED when faucet is in use.

- Batteries low (battery-powered models).
- Replace batteries (refer to battery replacement on page 157).

8. The water temperature is too hot or too cold on a faucet connected to hot and cold water supply lines.

- Supply stops are not adjusted properly.
Adjust supply stops.
- For models with integral side mixing valve—mixing valve is set improperly for the water temperature desired.
Rotate mixing valve handle clockwise to decrease water temperature or counterclockwise to increase water temperature.
- Inadequate hot water supply.
Adjust supply stops.

CARE AND CLEANING

DO NOT USE abrasive or chemical cleaners (including chlorine bleach) to clean Faucets that may dull the luster and attack the chrome or special decorative finishes. Use **ONLY** mild soap and water, then wipe dry with clean cloth or towel.

While cleaning the bathroom tile, protect the Faucet from any splattering of cleaner. Acids and cleaning fluids will discolor or remove chrome plating.

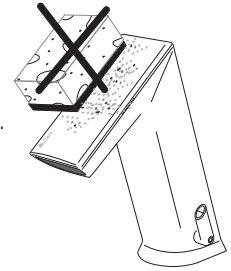

**When assistance is required, please contact
Sloan Technical Support at: 1-888-SLOAN-14 (1-888-756-2614).**

BASYS® Faucet Infrared Sensor Activated

UPGRADE FAUCET FUNCTIONALITY

Remove crown by loosening hex screw located on underside of spout and slide crown down and lift off.

NOTE: Screw is captive within faucet body and will NOT fall out.

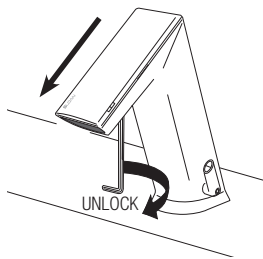

Place new crown on faucet by sliding onto spout and tightening hex screw on underside of spout.

NOTE: All electronics are fully encapsulated in the crown and thus protected from the environment and easy to replace or upgrade.

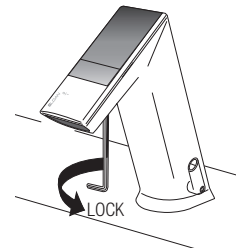
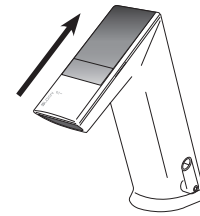

LED DISPLAY DIAGNOSTIC CODES

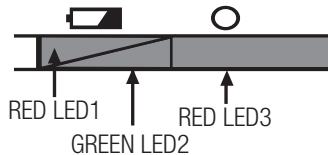

Function	LED1	LED2	LED3	Description 1	Description 2
Start Up Boot	RED	GREEN		LED1 and LED2 alternate blinking	Fast Toggle
Battery Check after Start Up	RED			LED1 on for 2 sec, if battery greater than 3.5V	
Line Power Check after Start Up			RED	LED3 on for 2 sec, if line power greater than 3.5V	
IR Adjust Process	RED			LED1 blinking while IR adjusts	Few seconds
IR Adjust IR		GREEN		LED2 on for 2 sec, if adjustment OK	
Battery Low	RED			LED1 blinks 3x, if battery is less than warning level	Only while in detection mode
Battery Empty	RED			LED1 double flashes 3x, if battery is less than empty level	Only while in detection mode
Valve Error			RED	LED3 double flashes 3x, if valve current error; flash after the 3rd error, off after the 3rd good operation	Flashes after the 3rd error, off after the 3rd good operation
IR Activation		GREEN		LED2 on for 2 sec, if IR-clic has been activated	After 5 sec. automatically back to operating mode
Cleaning Mode	RED			LED1 4-in-1 flash, if cleaning mode is activated	During "Cleaning Mode" is activated Permanent 4-in-1 flashes



BASYS® Faucet Infrared Sensor Activated



EFX-3XX SERIES

EFX-6XX SERIES

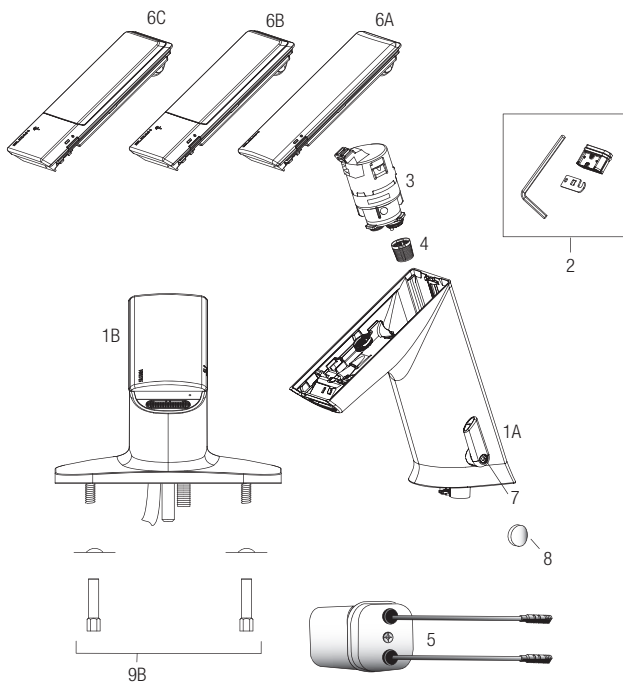

PARTS LIST—BASYS FAUCETS

Item No.	Code No.	Part No.	Description
1A.	—	—	Low Pedestal Faucet Assembly*
	—	—	Low Pedestal Faucet Assembly with Mixer*
1B.	—	—	Low Integrated Base Faucet Assembly†
2.	3324104	EFX-1002-A	0.5 gpm/1.9 Lpm Multi-Lam Spray Head (includes insert, o-ring, 2.5 mm allen key, and removal tool)
	3324103	EFX-1001-A	1.5 gpm/5.7 Lpm Aerated Stream Insert (includes insert, o-ring, 2.5 mm allen key, and removal tool)
	3324102	EFX-1000-A	1.5 gpm/5.7 Lpm Laminar Stream Insert (includes insert, o-ring, 2.5 mm allen key, and removal tool)
3.	—	EFX-37	0.5 gpm/1.9 Lpm Solenoid Valve Caddy Assembly — Low (Green)
	—	EFX-38	1.5 gpm/5.7 Lpm Solenoid Valve Caddy Assembly — Low (Blue)
4.	0324019	EFX-19	Strainer (Filter)
5.	3324117	EFX-23-A	Battery Pack Assembly
6A.	3324118	EFX-1-A	Crown Assembly
6B.	3324119	EFX-3-A	Solar Crown Assembly
6C.	3324120	EFX-4-A	Solar Crown with LCD Assembly
7.	—	—	Mixer Handle Assembly (for EFX-3 IR models only)
8.	—	EFX-25	Handle Cap (for EFX-3 IR models only)
9A.	0335000	EAF-1	Faucet Mounting Kit (for pedestal model only)
9B.	—	EFX-21-A	Faucet Mounting Kit (for integrated base model only)
10.	3335023	EAF-1008	13" (330 mm) Flexible Supply Hose (1)
11.	3324101	EFX-26-A	Trim Plate for 8" Centerset Sink
12.	3324100	EFX-20-A	Trim Plate for 4" Centerset Sink
13.	0335009	EAF-11	Plug-in Voltage Adapter (US)
	0335041	EAF-41	Plug-in Voltage Adapter (EU)
	0335039	EAF-39	Plug-in Voltage Adapter (UK)
	0335037	EAF-37	Box Type Voltage Adapter
14.	0335024	EAF-24-A	11-13/16" (300 mm) Extension Cable
	0335025	EAF-25-A	47-1/4" (1200 mm) Extension Cable
	0335015	EAF-17-A	126" (3200 mm) Extension Cable
15.	0335023	EAF-23-A	Splitter
16.	3326009	MIX-60-A	Mechanical, Below Deck Mixing Valve
17.	0326045	MIX-135-A	Thermostatic, Below Deck Mixing Valve
18.	3365461	ETF-617-A	Bak-Chek Tee

NOTE: If changing flow rate caddy and spray insert must be changed in conjunction.

† Single Supply faucets include Bak-Chek®

*Integral Base model not available with integral to faucet side mixer; single supply faucets include Bak-Chek®

— in Item No. column = Not shown in illustration

— in Code No. and Part No. column = Not sold separately

Electrical Connection for up to Six (6) Faucets Using One (1) Adapter

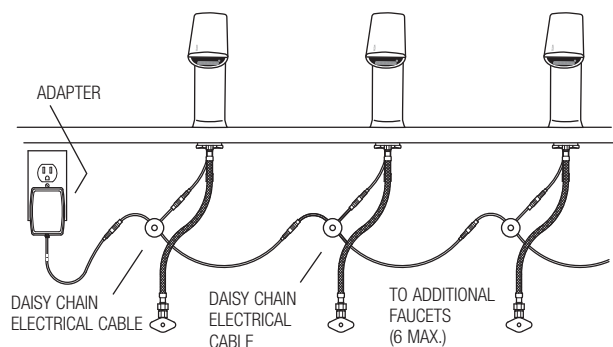

BASYS® Faucet Infrared Sensor Activated

REPLACING THE SOLENOID STRAINER (FILTER)

NOTE: Turning off water is not necessary, due to integrated automatic stop valve.

Remove crown by loosening hex screw located on underside of spout and slide crown down and lift off.

NOTE: Screw is captive within faucet body and will not fall out.

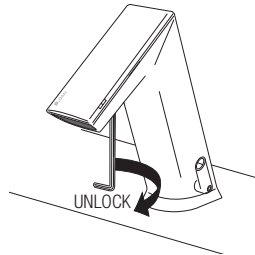

Remove battery pack assembly by lifting out of spout.

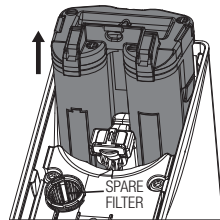

Rotate solenoid assembly counter-clockwise through a 45° angle.

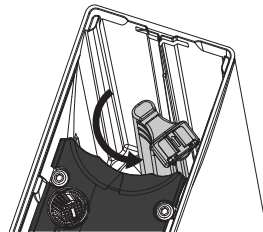

Pull solenoid caddy from faucet.

NOTE: STRAINER (FILTER) CAN BE REMOVED, CLEANED AND REPLACED AT THIS TIME.

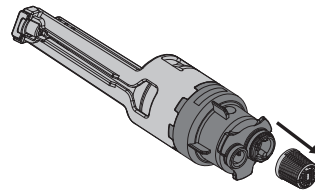

Insert new solenoid caddy at a 45° angle.

Rotate solenoid caddy clockwise to align with arrow, locking the unit and opening water path.

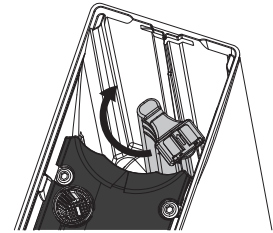

Reinsert battery pack assembly.

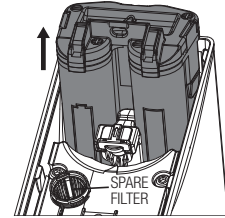

Slide on crown and secure.

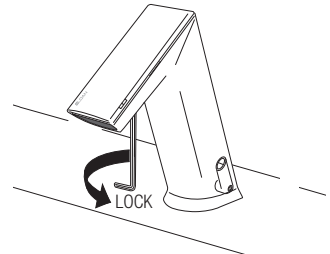

BASYS® Faucet Infrared Sensor Activated

SENSOR RANGE ADJUSTMENT

Factory setting is appropriate for the majority of applications and should not require resetting unless under extreme situations.

IR Activation

To enter programming mode place finger on IR clic 2 times then remove. Light on side of crown should blink red to indicate programming mode.

Cover IR clic until LED flashes 4x - hold on until LED flashes 1x to 8x, from minimum to maximum range. See diagram below. Release when requested range is reached.

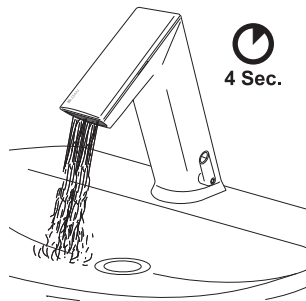
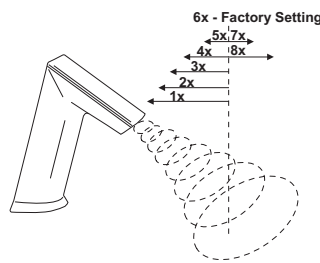
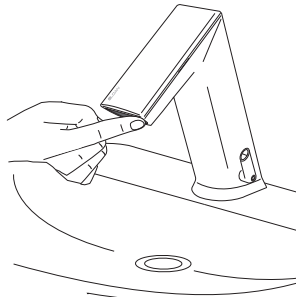

Wait until LED flashes GREEN.

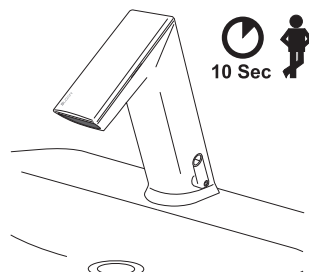

BATTERY REPLACEMENT

NOTE: Replace Battery when LED1 indicator flashes red each time faucet is in use or when faucet stops functioning. LED1 is identified by the battery symbol.

NOTE: Turning off water is not necessary.

Loosen cover screw and remove cover from battery pack.

Install four (4) AA-size batteries (supplied) as indicated by the (+) and (-) symbols inside the battery compartment.

Replace battery pack lid and tighten with screwdriver.

NOTE: Make sure batteries are installed with proper polarity. The cover of the case indicates polarity of batteries. Improper polarity will not harm the faucet. Improper polarity will cause the faucet not to operate.

*Replace all at once.

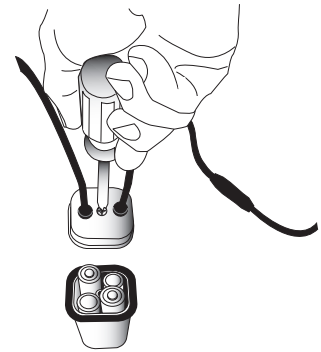

BASYS® Faucet Infrared Sensor Activated

OPERATION

As the user's hands enter the beam's effective range, the beam is reflected back into the sensor receiver and activates the solenoid valve allowing water to flow from the faucet. Water will flow until the hands are removed or until the faucet reaches its automatic time out limit setting.

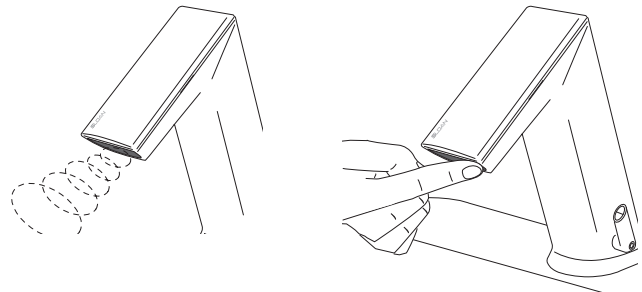

SET AND FIX TEMPERATURE AND ADJUST HOT LIMIT STOP

Adjust lever to set temperature.

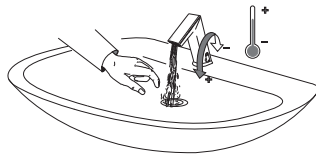

OPTIONAL – To fix temperature, set lever to the desired position, then remove lever and plug hole with cap.

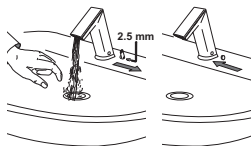

Optional Hot Limit Stop Adjustment – To adjust the hot/cold mix (factory set at 50/50) remove the lever.

Check to make sure dot is in center position before beginning adjustment.

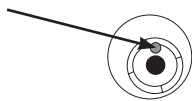
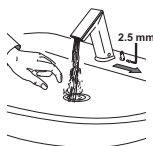

Faucet may be adjusted in 10° increments.



Function	Steps to Activate Function	Default Setting	IR Clic
IR Activation	Cover IR clic approximately for 2 sec. until LED will flash GREEN 1x - then remove finger from IR clic (Active for 5 sec.)	—	—
Cleaning Mode	IR activation; Cover IR clic 2x - confirmation of the function is active by a couple flashes by the LED; to return to normal operation cover IR clic 1x or the faucet will automatically return to normal function after 2 min.	2 min.	—
12/24 Line Purge Feature	See below.	Off	Off 12HR 24HR
Sensor Range Adjustment	See page 158.	6	1-8
Reset Electronics	IR activation; Cover IR clic 2x; LED will flash 5x Cover IR clic 1x for 5 sec. until LED flashes 4x, then remove finger from IR clic Wait for 20 sec. (After 10 sec. water will flow for 6 sec. and automatically adjust to environment)	Manually	—
Security Off	After 90 seconds (max) of hand and/or object within sensor appears permanent, waterflow will stop and will remeasure environment	On	—

Please contact factory for more extensive programming options.

12/24 LINE PURGE FEATURE

This feature will operate the faucet every 12 or 24 hours since last use, if not used to prevent stagnant water conditions.

Default purge duration is two minutes.

Consult factory regarding other timing options.

IR activation (see above). Cover IR clic approximately 24 sec. (ignore LED indications during this period). Release when requested program is reached. (See diagram to right). Programming mode will time out after 2 minutes if no changes are made.

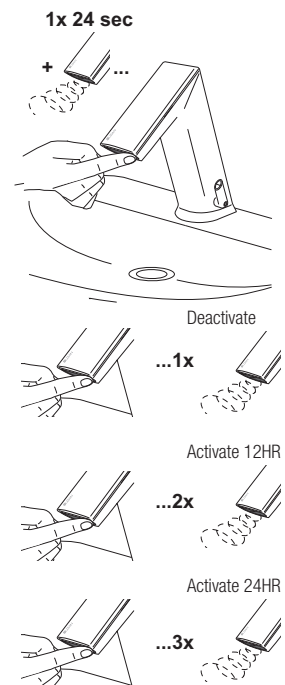

BASYS® Faucet Infrared Sensor Activated

UPGRADE FAUCET FUNCTIONALITY

Remove crown by loosening hex screw located on underside of spout and slide crown down and lift off.

NOTE: Screw is captive within faucet body and will not fall out.

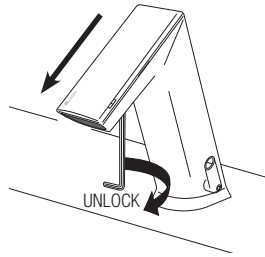

Place new crown on faucet by sliding onto spout and tightening hex screw on underside of spout.

NOTE: All electronics are fully encapsulated in the crown and thus protected from the environment and easy to replace or upgrade.

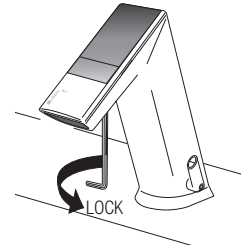
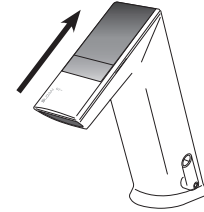

LED DISPLAY DIAGNOSTIC CODES

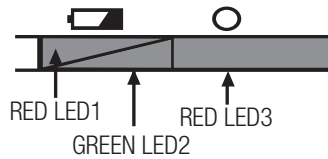

RED **GREEN** COLOR LEDs BLINKING

RED **GREEN** COLOR LEDs ON

Function	LED1	LED2	LED3	Description 1	Description 2
Start Up Boot	RED	GREEN		LED1 and LED2 alternate blinking	Fast Toggle
Battery Check after Start Up	RED			LED1 on for 2 sec, if battery greater than 3.5V	
Line Power Check after Start Up			RED	LED3 on for 2 sec, if line power greater than 3.5V	
IR Adjust Process	RED			LED1 blinking while IR adjusts	Few seconds
IR Adjust IR		GREEN		LED2 on for 2 sec, if adjustment OK	
Battery Low	RED			LED1 blinks 3x, if battery is less than warning level	Only while in detection mode
Battery Empty	RED			LED1 double flashes 3x, if battery is less than empty level	Only while in detection mode
Valve Error			RED	LED3 double flashes 3x, if valve current error; flash after the 3rd error, off after the 3rd good operation	Flashes after the 3rd error, off after the 3rd good operation
IR Activation		GREEN		LED2 on for 2 sec, if IR-clic has been activated	After 5 sec. automatically back to operating mode
Cleaning Mode	RED			LED1 4-in-1 flash, if cleaning mode is activated	During "Cleaning Mode" is activated Permanent 4-in-1 flashes



BASYS® Faucet Infrared Sensor Activated

REPLACING THE SOLENOID STRAINER (FILTER)

NOTE: Turning off water is not necessary, due to integrated automatic stop valve.

Remove crown by loosening hex screw located on underside of spout and slide crown down and lift off.

NOTE: Screw is captive within faucet body and will not fall out.

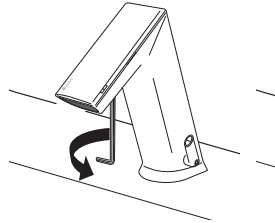

Rotate solenoid assembly counter-clockwise through a 45° angle.

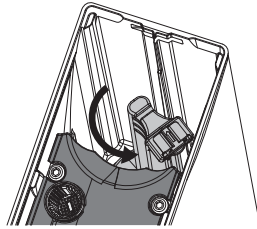

Pull solenoid caddy from faucet.

NOTE: Strainer can be removed, cleaned and replaced at this time.

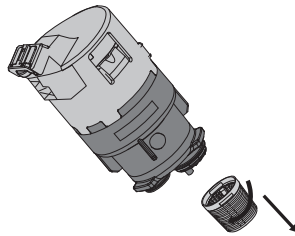

Insert new solenoid caddy at a 45° angle.

Rotate solenoid caddy clockwise to align with arrow, locking the unit and opening water path.

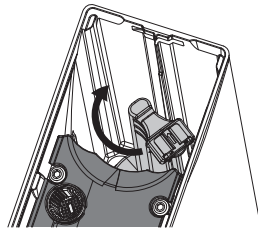

Slide on crown and secure.

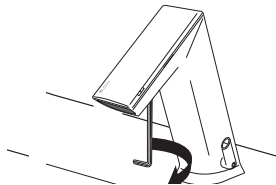

REPLACE SPRAY INSERT

NOTE: Turning off water is not necessary, due to integrated automatic stop valve.

Remove crown by loosening hex screw located on underside of spout and slide crown down and lift off.

NOTE: Screw is captive within faucet body and will not fall out.

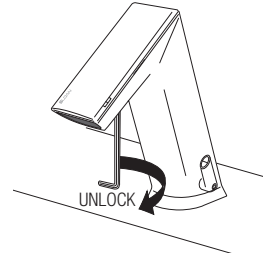

Retrieve spray removal tool located near the spray insert.

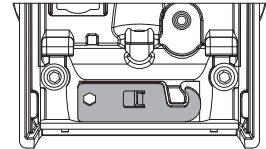

Insert spray removal tool into spray slot by sliding hook end of key between faucet spout and insert. Pull insert out of faucet once hooked.

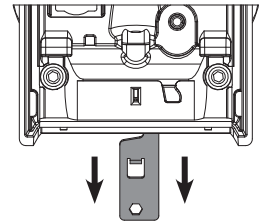

Install new insert.

NOTE: If changing to a different flow rate solenoid caddy must be changed in conjunction.

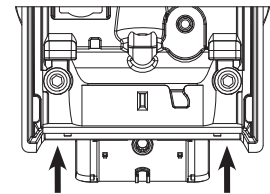

Return spray removal tool to storage location.

NOTE: This can only be done once spray head is installed. This will lock the spray head in place.

NOTE: If spray head is inserted incorrectly – key will not lock in properly. Turn faucet on to push insert out and re-install.

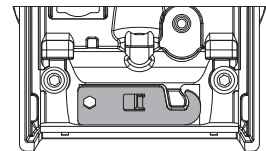

Slide on crown and secure.

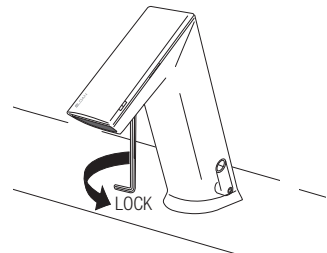

BASYS® Faucet Infrared Sensor Activated

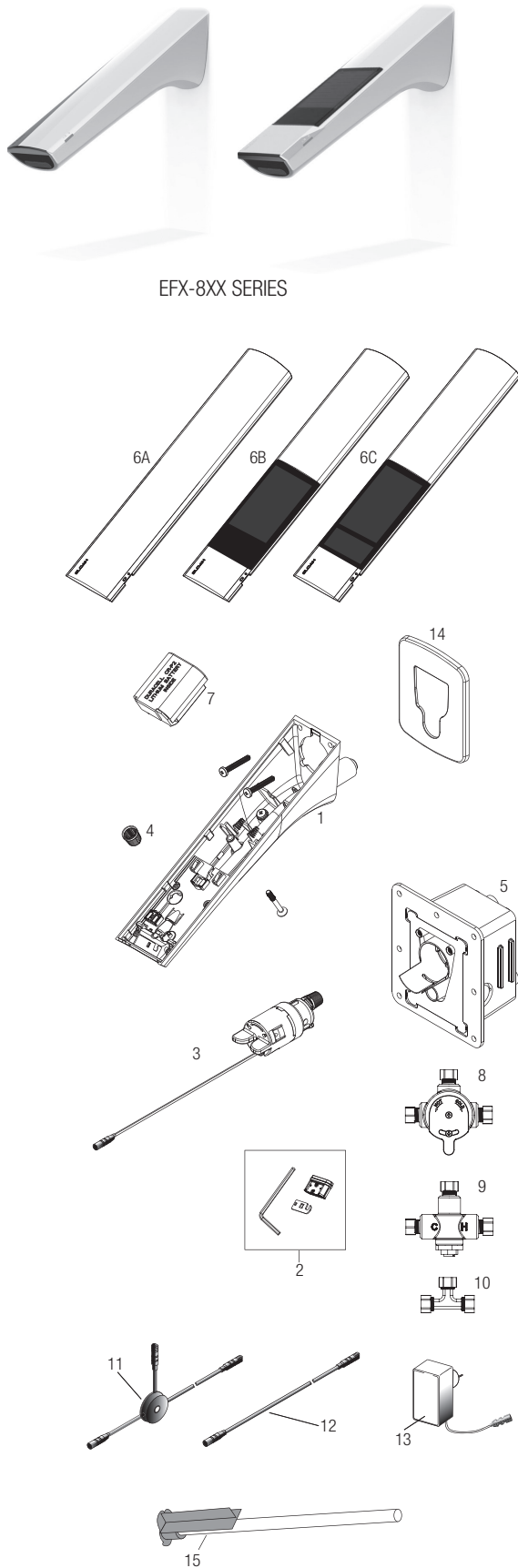

PARTS LIST—BASYS FAUCETS

Item No.	Code No.	Part No.	Description
1.	—	—	Wall Mount Faucet Assembly
2.	3324104	EFX-1002-A	0.5 gpm/1.9 Lpm Multi-Lam Spray Head (includes insert, o-ring, 2.5 mm allen key, and removal tool)
	3324103	EFX-1001-A	1.5 gpm/5.7 Lpm Aerated Stream Insert (includes insert, o-ring, 2.5 mm allen key, and removal tool)
	3324102	EFX-1000-A	1.5 gpm/5.7 Lpm Laminar Stream Insert (includes insert, o-ring, 2.5 mm allen key, and removal tool)
3.	3324162	EFX-1011-A	0.5 gpm/1.9 Lpm Solenoid Valve Caddy Assembly – Wall (Green) ‡
	3324163	EFX-1012-A	1.5 gpm/5.7 Lpm Solenoid Valve Caddy Assembly – Wall (Blue) ‡
4.	0324019	EFX-19	Strainer (Filter)
5.	—	EFX-1013-A	Mounting Assembly
6A.	3324160	EFX-1009-A	Bowed Crown Assembly
6B.	3324138	EFX-1010-A	Solar Crown Assembly
6C.	3324139	EFX-1018-A	Solar Crown with LCD Assembly
7.	—	—	CR-P2 Lithium Battery
8.	3326009	MIX-60-A	Mechanical, Below Deck Mixing Valve
9.	0326045	MIX-135-A	Thermostatic, Below Deck Mixing Valve
10.	3365461	ETF-617-A	Bak-Chek Tee Assembly
11.	0335023	EAF-23-A	Splitter
12.	0335024	EAF-24-A	11-13/16" (300 mm) Extension Cable
	0335025	EAF-25-A	47-1/4" (1200 mm) Extension Cable
	0335015	EAF-17-A	126" (3200 mm) Extension Cable
13.	0335009	EAF-11	Plug-in Voltage Adapter (US)
	0335041	EAF-41	Plug-in Voltage Adapter (EU)
	0335039	EAF-39	Plug-in Voltage Adapter (UK)
	0335037	EAF-37	Box Type Voltage Adapter
14.	3324165	EFX-1014-A	Wall Flange
15.	—	—	Purge Tool

NOTE: If changing flow rate caddy and spray insert must be changed in conjunction.

† Single Supply faucets include Bak-Chek®

— in Item No. column = Not shown in illustration

— in Code No. and Part No. column = Not sold separately

‡ Old style / T-shaped contact.

New style / Plug contact

Electrical Connection for up to Six (6) Faucets Using One (1) Adapter

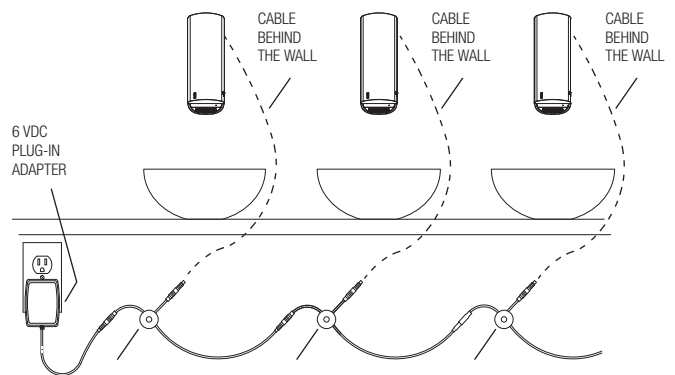

BASYS® Faucet Infrared Sensor Activated

TROUBLESHOOTING GUIDE

1. Red LED in spout does not blink 2 seconds after battery installation.

- Battery placement incorrect or batteries have been discharged.
- Ensure batteries are installed properly. Check the orientation of each battery matches the positive (+) and negative (-) symbols shown on the battery compartment.

2. Faucet DOES NOT function.

- Adhesive packaging label affixed over sensor eye.
- Remove adhesive label from sensor eye.

3. Faucet delivers water in an uncontrolled manner.

- Clean sensor window; if problem persists contact Sloan Tech Support.

4. Faucet DOES NOT deliver any water when sensor is activated.

INDICATOR: Solenoid valve produces an audible "CLICK".

- Water supply stop(s) closed.
Open water supply stop(s).
- Strainer is clogged.
Remove, clean, and reinstall strainer. Replace strainer, if needed (refer to page 164).

5. Solenoid valve DOES NOT produce an audible "CLICK".

- Batteries low (battery powered models).
Replace batteries.
- Power failure (hardwire models). Check power supply.

6. Faucet delivers only a slow flow or dribble when sensor is activated.

- Water supply stop(s) are partially closed. Completely open water supply stop(s).

7. Faucet DOES NOT stop delivering water or continues to drip after user is no longer detected.

- Faucet is not working properly.
- Clean sensor window; if problem persists contact Sloan Tech Support.

8. LED indicator blinks RED when faucet is in use.

- Batteries low (battery powered models).
- Replace batteries (refer to battery replacement on page 164).

9. The water temperature is too hot or too cold on a faucet connected to hot and cold water supply lines.

- Supply stops are not adjusted properly. Adjust supply stops.
- For models with integral side mixing valve—Mixing valve is set improperly for the water temperature desired. Rotate mixing valve handle clockwise to decrease water temperature or counterclockwise to increase water temperature.
- Inadequate hot water supply. Adjust supply stops.

CARE AND CLEANING

DO NOT USE abrasive or chemical cleaners (including chlorine bleach) to clean faucets that may dull the luster and attack the chrome or special decorative finishes. Use **ONLY** mild soap and water, then wipe dry with clean cloth or towel.

While cleaning the bathroom sink, protect the faucet from any splattering of cleaner. Acids and cleaning fluids will discolor or remove chrome plating.

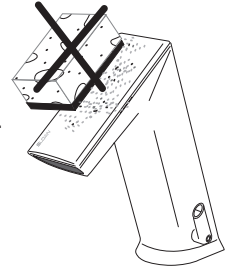

When assistance is required, please contact Sloan Technical Support at: 1-888-SLOAN-14 (1-888-756-2614).

BASYS® Faucet Infrared Sensor Activated

SENSOR RANGE ADJUSTMENT

Factory setting is appropriate for the majority of applications and should not require resetting unless under extreme situations: high reflection or low light.

IR Activation (see previous page). To enter programming mode place finger on IR clic 2 times then remove. Light on side of crown should blink to indicate programming mode.

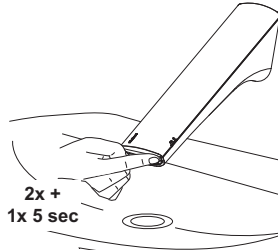

Cover IR clic until LED flashes RED 4 times - hold IR clic on until LED flashes 1 time to 8 times from minimum to maximum range. See diagram below. Release when requested range is reached.

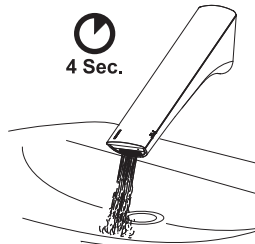
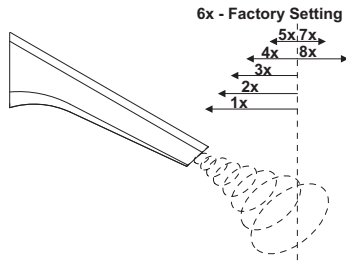

Wait, until LED flashes GREEN.



BATTERY REPLACEMENT

NOTE: Replace battery when LED1 indicator flashes RED each time faucet is in use or when faucet stops functioning. LED1 is identified by the battery symbol.

NOTE: Turning off water is not necessary.

Remove crown by loosening 2 hex screws located on underside of spout and slide crown down and lift off.

NOTE: Screw is captive within faucet body and will NOT fall out.

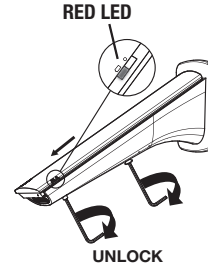

Remove red cover over the battery. Remove battery holder from the faucet body. Replace battery in the holder. Holder drops into the faucet body. Place the red cover over the battery.

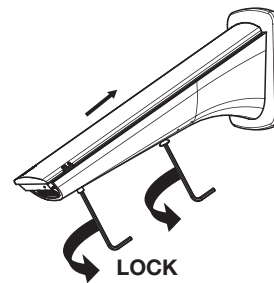
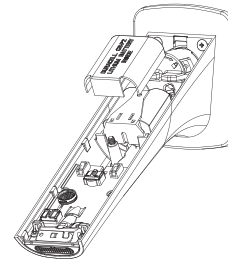

Slide on crown and secure in 2 places.

BASYS® Faucet

Infrared Sensor Activated

OPERATION

As the user's hands enter the beam's effective range, the beam is reflected back into the sensor receiver and activates the solenoid valve allowing water to flow from the faucet. Water will flow until the hands are removed or until the faucet reaches its automatic time out limit setting.

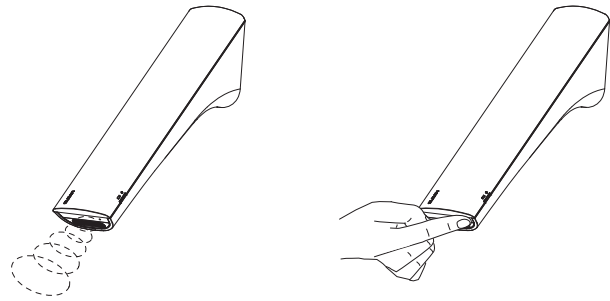
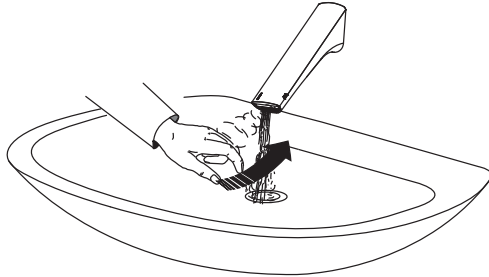

Function	Steps to Activate Function	Default Setting	IR Clic
IR Activation	Cover IR clic approximately for 2 sec. until LED will flash GREEN 1x - then remove finger from IR clic (Active for 5 sec.)	—	—
Cleaning Mode	IR activation; Cover IR clic 2x - confirmation of the function is active by a couple flashes by the LED; to return to normal operation cover IR clic 1x or the faucet will automatically return to normal function after 2 min.	2 min.	—
12/24 Line Purge Feature	See below.	Off	Off 12HR 24HR
Sensor Range Adjustment	See next page.	6	1-8
Reset Electronics	IR activation; Cover IR clic 2x; LED will flash 5x Cover IR clic 1x for 5 sec. until LED flashes 4x, then remove finger from IR clic Wait for 20 sec. (After 10 sec. water will flow for 6 sec. and automatically adjust to environment)	Manually	—
Security Off	After 90 seconds (max) of hand and/or object within sensor appears permanent, waterflow will stop and will remeasure environment	On	—

Please contact factory for more extensive programming options.

12/24 LINE PURGE FEATURE

This feature will operate the faucet every 12 or 24 hours since last use, if not used to prevent stagnant water conditions.

Default purge duration is two minutes.

Consult factory regarding other timing options.

IR activation (see above). Cover IR clic approximately 24 sec. (ignore LED indications during this period). Release when requested program is reached. (See diagram to right). Programming mode will time out after 2 minutes if no changes are made.

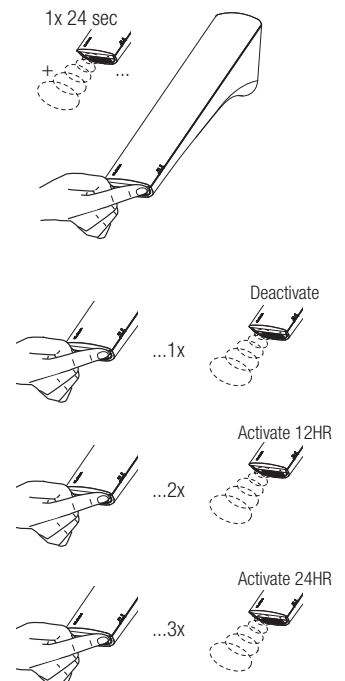

BASYS® Faucet Infrared Sensor Activated

UPGRADE FAUCET FUNCTIONALITY

Remove crown by loosening hex screw located on underside of spout and slide crown down and lift off.

NOTE: Screw is captive within faucet body and will NOT fall out.



Place new crown on faucet by sliding onto spout and tightening hex screw on underside of spout.

NOTE: All electronics are fully encapsulated in the crown and thus protected from the environment and easy to replace or upgrade.

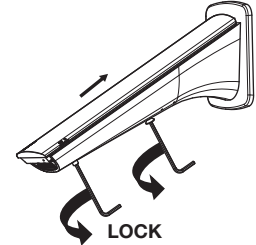

LED DISPLAY DIAGNOSTIC CODES

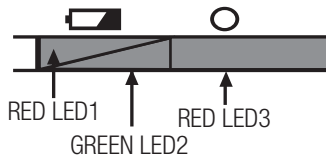

RED **GREEN** COLOR LEDs BLINKING

RED **GREEN** COLOR LEDs ON

Function	LED1	LED2	LED3	Description 1	Description 2
Start Up Boot	RED GREEN			LED1 and LED2 alternate blinking	Fast Toggle
Battery Check after Start Up	RED			LED1 on for 2 sec, if battery greater than 3.5V	
Line Power Check after Start Up			RED	LED3 on for 2 sec, if line power greater than 3.5V	
IR Adjust Process	RED			LED1 blinking while IR adjusts	Few seconds
IR Adjust IR		GREEN		LED2 on for 2 sec, if adjustment OK	
Battery Low	RED			LED1 blinks 3x, if battery is less than warning level	Only while in detection mode
Battery Empty	RED			LED1 double flashes 3x, if battery is less than empty level	Only while in detection mode
Valve Error			RED	LED3 double flashes 3x, if valve current error; flash after the 3rd error, off after the 3rd good operation	Flashes after the 3rd error, off after the 3rd good operation
IR Activation		GREEN		LED2 on for 2 sec, if IR-clic has been activated	After 5 sec. automatically back to operating mode
Cleaning Mode	RED			LED1 4-in-1 flash, if cleaning mode is activated	During "Cleaning Mode" is activated Permanent 4-in-1 flashes



BASYS® Faucet Infrared Sensor Activated

REPLACING THE SOLENOID STRAINER (FILTER)

NOTE: Turning off water is not necessary, due to integrated automatic stop valve.

Remove crown by loosening hex screw located on underside of spout and slide crown down and lift off.

NOTE: Screw is captive within faucet body and will NOT fall out.



Rotate solenoid assembly counter-clockwise through a 45° angle.

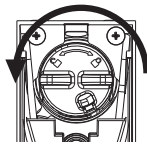

Pull solenoid caddy from faucet.
NOTE: Strainer can be removed, cleaned, and replaced at this time.

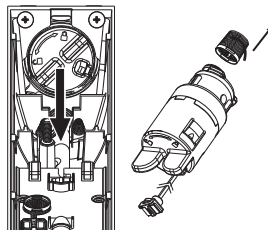

Insert new solenoid caddy at a 45° angle.

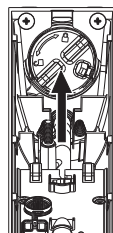

Rotate solenoid caddy clockwise to align with arrow, locking the unit and opening water path.

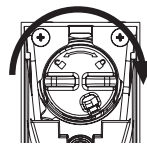

Slide on crown and secure in 2 places.

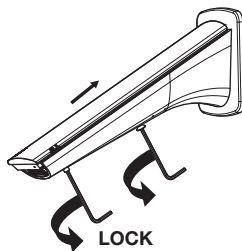

REPLACE SPRAY INSERT

NOTE: Turning off water is not necessary, due to integrated automatic stop valve.

Remove crown by loosening hex screw located on underside of spout and slide crown down and lift off.

NOTE: Screw is captive within faucet body and will NOT fall out.



Retrieve spray removal tool located near the spray insert.

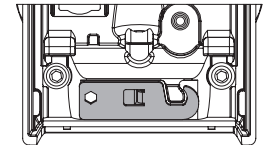

Insert spray removal tool into spray slot by sliding hook end of key between faucet spout and insert. Pull insert out of faucet once hooked.

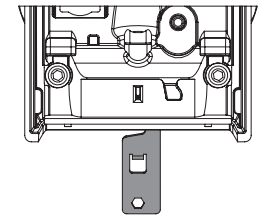

Install new insert.

NOTE: If changing to a different flow rate, solenoid caddy must be changed in conjunction.

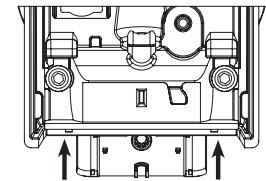

Return spray removal tool to storage location.

NOTE: This can only be done once spray head is installed. This will lock the spray head in place.

NOTE: If spray head is inserted incorrectly, key will not lock in properly. Turn faucet on to push insert out and re-install.

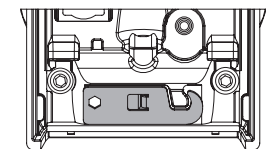

Slide on crown and secure.

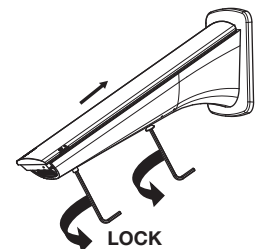

BASYS® Faucet

Capacitance Sensing Activated

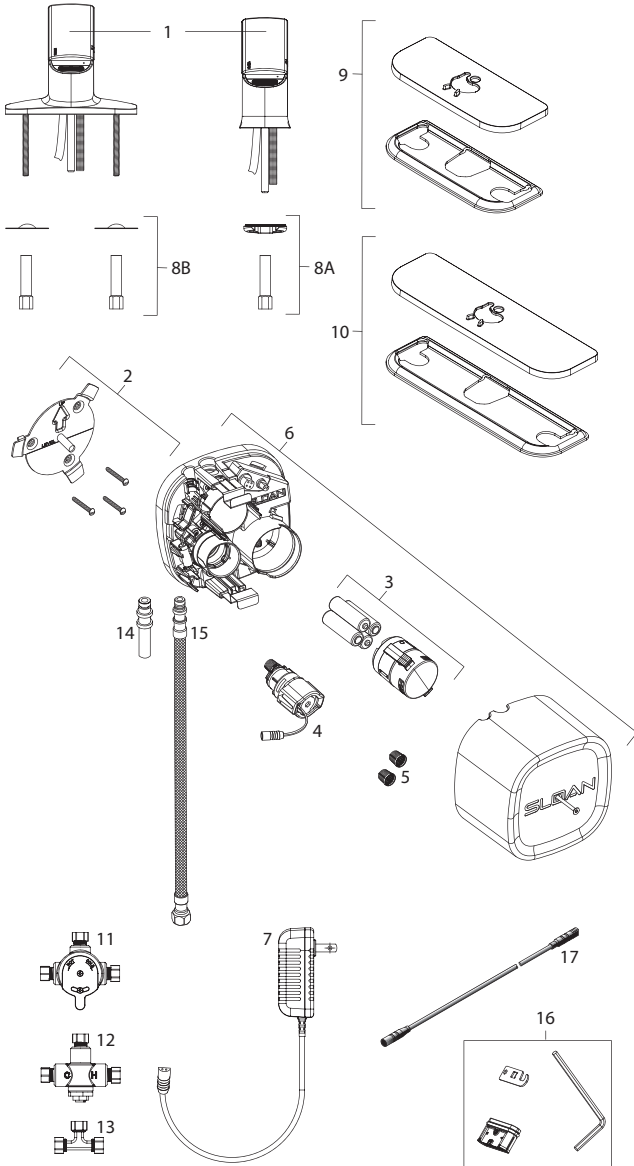

PARTS LIST—BASYS FAUCETS

Item No.	Code No.	Part No.	Description
1.	3324112	EFX-2-A	Standard Crown (Capacitance)
2.	0324036	EFX-36	Control Module Mounting Kit
3.	3324113	EFX-8	Battery Pack
4.	3324114	EFX-13-A	Solenoid Valve Caddy 0.5 gpm (1.9 Lpm)
	3324115	EFX-14-A	Solenoid Valve Caddy 1.5 gpm (5.7 Lpm)
5.	0324019	EFX-19	Filter / Strainers
6.	3324105	EFX-1003-A	Control Module Assembly – 0.5 gpm (1.9 Lpm)
	3324106	EFX-1004-A	Control Module Assembly with Turbine – 0.5 gpm (1.9 Lpm)
	3324107	EFX-1005-A	Control Module Assembly – 1.5 gpm (5.7 Lpm)
	3324108	EFX-1006-A	Control Module Assembly with Turbine – 1.5 gpm (5.7 Lpm)
7.	0324031	EFX-31	120 VAC/6.75 VDC Plug-in Voltage Adapter
8A.	0335000	EAF-1	Faucet Spout Mounting Kit (Pedestal)
8B.	0324021	EFX-21-A	Faucet Spout Mounting Kit (Integrated Base)
9.	3324100	EFX-20-A	4-inch (102 mm) Centerset Base Plate Kit
10.	3324101	EFX-26-A	8-inch (203 mm) Centerset Base Plate Kit
11.	3326009	MIX-60-A	Below Deck Mechanical Mixing Valve
12.	0326045	MIX-135-A	Below Deck Thermostatic Mixing Valve
13.	0324033	ETF-617-A	Bak-Chek® Tee
14.	0324034	EFX-33	Inlet Hose Fitting
15.	3324102	EFX-34	Flexible Supply Hose 18" (45 mm)
16.	3324104	EFX-1002-A	0.5 gpm (1.9 Lpm) Multi-Lam Spray Insert, includes: insert, o-ring, insert removal tool, and hex key
	3324103	EFX-1001-A	1.5 gpm (5.7 Lpm) Aerated Stream Insert includes: insert, o-ring, insert removal tool, and hex key
	3324102	EFX-1000-A	1.5 gpm (5.7 Lpm) Laminar Stream Insert includes: insert, o-ring, insert removal tool, and hex key
17.	0335024	EAF-24-A	11-13/16" (300 mm) Extension Cable
	0335025	EFX-25-A	47-1/4" (1200 mm) Extension Cable
	0335015	EFX-17-A	126" (3200 mm) Extension Cable

NOTE: If changing flow rate, caddy and spray insert must be changed in conjunction. Manufactured by Sloan Valve Company under one or more of the following U.S. Patents: 7,690,623; 7,069,941; 6,619,320.
 — in Item No. column = Not shown in illustration
 — in Code No. and Part No. column = Not sold separately

IMPORTANT
 Not for installation on a metal sink or deck (i.e. stainless steel or cast metal).

BASYS® Faucet

Capacitance Sensing Activated

TROUBLESHOOTING GUIDE

1. RED LED in spout DOES NOT blink 2 seconds after battery installation.

- A. Battery placement incorrect or batteries have been discharged. Ensure batteries are installed properly. Check the orientation of each battery matches the positive (+) and negative (–) symbols shown on the battery compartment.

2. Faucet DOES NOT function.

- A. Adhesive packaging label affixed over sensor eye. Remove adhesive label from sensor eye.

3. Faucet delivers water in an uncontrolled manner.

- A. Clean sensor window; if problem persists, contact Sloan Technical Support).

4. Faucet DOES NOT deliver any water when sensor is activated.

INDICATOR: Solenoid valve produces an audible “CLICK”.

- A. Water supply stop(s) closed. Open water supply stop(s).
- B. Strainer is clogged. Remove, clean, and reinstall strainer. Replace strainer (filter), if needed (refer to page 166).

INDICATOR: Solenoid valve DOES NOT produce an audible “CLICK”.

- A. Batteries low (battery-powered models). Replace batteries (refer to battery replacement on page 163).
- B. Power failure (hardwire models). Check power supply.

5. Faucet delivers only a slow flow or dribble when sensor is activated.

- A. Water supply stop(s) are partially closed. Completely open water supply stop(s).

6. Faucet DOES NOT stop delivering water or continues to drip after user is no longer detected.

- A. Clean sensor window; if problem persists, contact Sloan Technical Support.

7. LED indicator blinks RED when faucet is in use.

- A. Batteries low (battery-powered models). Replace batteries (refer to battery replacement on page 166).

8. The water temperature is too hot or too cold on a faucet connected to hot and cold water supply lines.

- A. Supply stops are not adjusted properly. Adjust supply stops.
- B. For models with integral side mixing valve—mixing valve is set improperly for the water temperature desired. Rotate mixing valve handle clockwise to decrease water temperature or counterclockwise to increase water temperature.
- C. Inadequate hot water supply. Adjust supply stops.

CARE AND CLEANING

DO NOT USE abrasive or chemical cleaners (including chlorine bleach) to clean faucets that may dull the luster and attack the chrome or special decorative finishes. Use **ONLY** mild soap and water, then wipe dry with clean cloth or towel.

While cleaning the bathroom sink, protect the faucet from any splattering of cleaner. Acids and cleaning fluids will discolor or remove chrome plating.

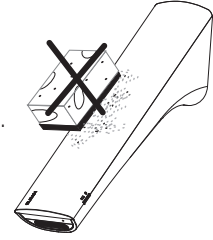

When assistance is required, please contact Sloan Technical Support at: 1-888-SLOAN-14 (1-888-756-2614).

BASYS® Faucet Capacitance Sensing Activated

REPLACE FILTER

Disconnect solenoid wire from control module.

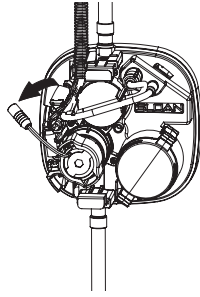

Remove new filter from control module cover.

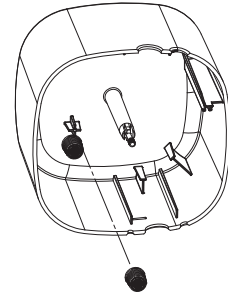

Turn solenoid caddy counterclockwise, lining up arrows on control module and solenoid caddy assembly.

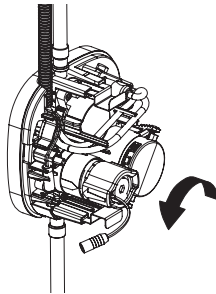

Snap new filter onto solenoid caddy assembly.

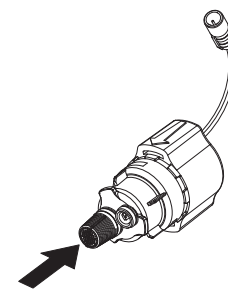

Remove solenoid caddy assembly from control module by pulling straight out.

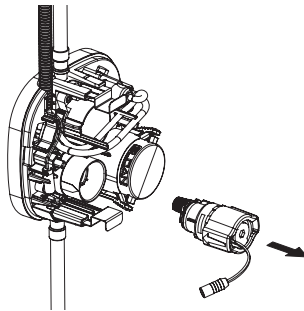

Insert solenoid caddy assembly into control module lining up arrows. Turn solenoid caddy assembly clockwise 45°.

Reconnect solenoid caddy wire to control module.

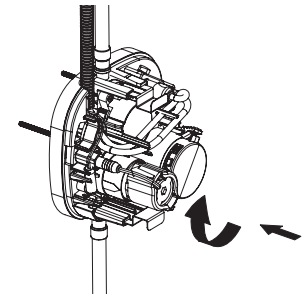

Remove filter from solenoid caddy assembly.

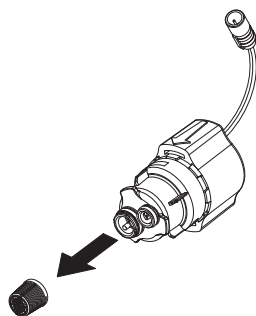

BASYS® Faucet Capacitance Sensing Activated

OPERATION OF FAUCET

A continuous ambient field is emitted and monitored by the faucet system. As the user's hands enter the effective range, the sensor activates the solenoid valve allowing tempered water to flow from the faucet. Water will flow until the hands are removed or until the faucet reaches its automatic time out setting. When hands are moved away from the faucet, the capacitance sensor deactivates the solenoid valve, shutting off the water flow. The system automatically resets and is ready for the next user.

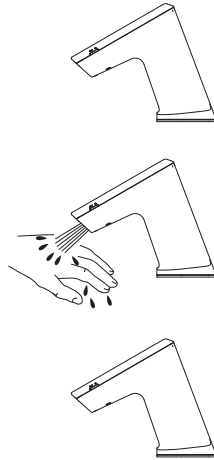

Twist top of battery pack counter-clockwise to open. Remove batteries and replace batteries with four (4) new "AA" batteries. Twist top of battery pack clockwise to close.

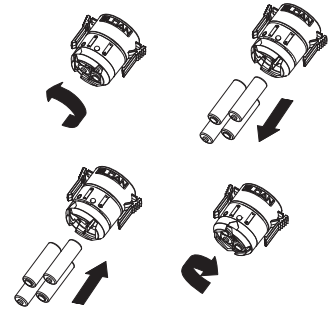

Replace cover.

BATTERY REPLACEMENT

NOTE: REPLACE BATTERY WHEN RED BATTERY INDICATOR LED FLASHES 4 TIMES EACH TIME FAUCET IS IN USE OR WHEN FAUCET STOPS FUNCTIONING.

No need to turn off water.

Loosen screw with hex wrench and remove cover.

NOTE: IT IS POSSIBLE FOR THE FAUCET TO ACTIVATE WHEN THE CAP WIRE OR SOLENOID IS TOUCHED OR WHEN THE CONTROL MODULE COVER IS BEING SCREWED ONTO THE MANIFOLD.

Slide cover forward and lift off.

Remove battery case.

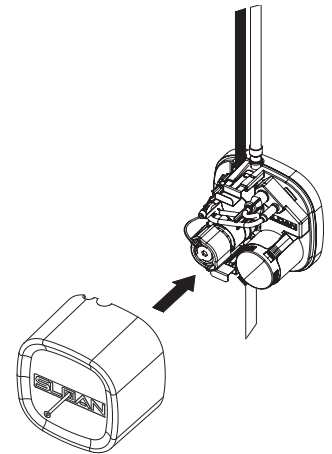
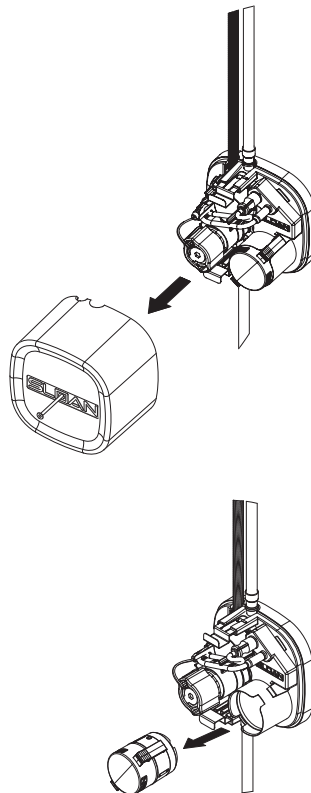

BASYS® Faucet

Capacitance Sensing Activated

LED DISPLAY DIAGNOSTIC CODES

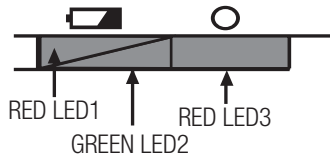

NOTE: LED1 and LED2 are for battery and programming related items. LED3 is for solenoid service.

Function	LED1	LED2	LED3	Notes
Power Up Success (Battery Only Models)		Blinks 5x		Blinks 1 every second (5 seconds); for battery power
Power Up Success (Adapter Models)	Blinks 3-5x	Blinks 3-5x		Blinks 1 every second (5 seconds); for adapter power
Low Battery	Blinks 4x			Battery power is low; During hand detection
Clean Mode		Blinks		Once every 2 seconds; Touch faucet body more than 8 seconds, water hold for 2 minutes
Water Hold		Blinks		Once every 1 second; If water turns on/off 5 times in 20 seconds, faucet turns off for 1 minute
Solenoid Latch Failure			Blinks	Two LED blinks; After hand removed from detection zone
Cap Sensor Fails to Calibrate		Blinks		4 times per second; Before first water burst detection for cable is not installed correctly
Ambient Electrical Noise Too High		Blinks		4 times per seconds; After first water burst

TROUBLESHOOTING GUIDE

1. Faucet DOES NOT function.

- Batteries not installed.
Install batteries.
- Capacitance cable not connected.
Connect cable.

2. Faucet delivers water in an uncontrolled manner.

- Contact Sloan Technical Support.

3. Faucet DOES NOT deliver any water when sensor is activated. Solenoid valve produces an audible "CLICK."

- Water supply stop(s) closed.
Open water supply stop(s).
- Water supply stop strainer(s) clogged.
Remove, clean, and reinstall water supply stop strainer(s). Replace strainer(s), if required.

Solenoid valve DOES NOT produce an audible "CLICK."

- Battery low (battery powered models).
Replace battery (refer to Battery Replacement section of guide).
- Power failure.
Check power supply.

4. Faucet DOES NOT stop delivering water or continues to drip after user is no longer detected.

- Contact Sloan Technical Support.

5. Faucet delivers only a slow flow or dribble when sensor is activated.

- Water supply stop(s) are partially closed.
Completely open water supply stop(s).
- Water supply stop strainer(s) clogged.
Remove, clean, and reinstall water supply stop strainer(s). Replace strainer(s), if required.
- Spray head is clogged.
Remove, clean, and reinstall spray head. Replace spray head, if required.
- Contact Sloan Technical Support.

6. LED indicator blinks when faucet is in use.

- Battery low (battery powered models).
Replace battery (refer to Battery Replacement section of guide).

7. The water temperature is too hot or too cold on a faucet connected to hot and cold supply lines.

- Supply stops are not adjusted properly.
Adjust supply stops.

CARE AND CLEANING

DO NOT USE abrasive or chemical cleaners (including chlorine bleach) to clean faucets that may dull the luster and attack the chrome or special decorative finishes. Use **ONLY** mild soap and water, then wipe dry with clean cloth or towel. While cleaning the bathroom sink, protect the faucet from any splattering of cleaner. Acids and cleaning fluids will discolor or remove chrome plating.

When assistance is required, please contact Sloan Technical Support at: 1-888-SLOAN-14 (1-888-756-2614).

Optima® EBF-85/EBF-187/ETF-80/ETF-880 Faucets Parts & Accessories



EBF-85 Deck mount, battery
ETF-80 Deck mount, hardwired



EBF-187 Deck mount, battery
ETF-880 Deck mount, hardwired

EFP61A (BLACK)
EFP62A (METAL)

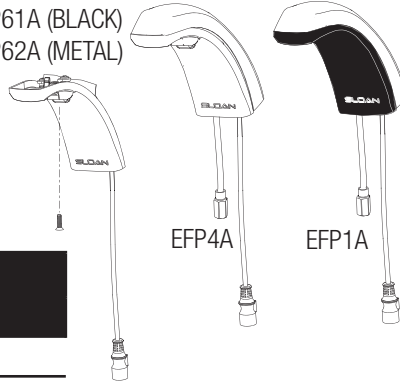

EFP4A

EFP1A

ETF1038A
ETF1021A
ETF1041A
ETF1028A
ETF1022A

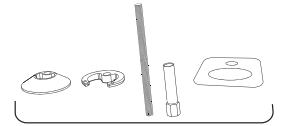

EFP37A

SPOUT ASSEMBLY

Description	Code No.	Part No.
Spout Assembly EBF-85/ETF-80	0367001	EFP1A
Spout Assembly EBF187/ETF-880	0367004	EFP4A
Sensor & Cable Assembly-EBF-85/ETF-80	0367061	EFP61A
Sensor & Cable Assembly-EBF-187/ETF-880	0367062	EFP62A
Sensor Mounting Kit	0367037	EFP37A

SPRAYHEAD OPTIONS

Description	Type	Code No.	Part No.
0.35 GPM/1.3 Lpm	MLM	3365755	ETF1038A
0.5 GPM/1.9 Lpm	MLM	3365091	ETF1021A
1.0 GPM/3.8 Lpm	MLM	3365557	ETF1041A
1.5 GPM/5.7 Lpm	LAM	3365161	ETF1028A
2.2 GPM/8.3 Lpm	LAM	3365160	ETF1027A
2.2 GPM/8.3 Lpm	AER	3365090	ETF1022A

TRIMPLATE OPTIONS

Description	Code No.	Part No.
4"	3365468	ETF312A
8"	3365024	ETF510A
4" Centerset (ETF-80/EBF-85)	3365466	ETF662A
4" Centerset (EBF-187/ETF-880)	3365603	ETF433A

BELOW DECK ASSEMBLIES

Description	Code No.	Part No.
Control Box No Turbine	0367039	EFP39A
Control Box Turbine 0.5 gpm	0367040	EFP40A
Control Box Turbine 1.5 gpm	0367011	EFP11A
Quick Connect Spout Hose 24"	0367025	EFP25
Control Box Cover w/Screw	0367010	EFP10A
Solenoid Assembly	0367103	EFP103A
Battery Pack	3324113	EFX8A
Double Inlet Tee Filter Assembly	0367028	EFP28A
BDM & Single Inlet Tee Filter Assembly Kit	0367099	EFP99A
BDT & Single Inlet Tee Filter Assembly Kit	0367100	EFP100A
Replacement Filter Pack-(5) Filter (5) Large O-rings (5) Small O-rings	0367101	EFP101A
24 VAC Power Harness Assembly	0367098	EFP98A
110V/6 VDC Power Supply	0362006	SFP6
100-240 VAC/6 VDC Power Supply	0362016	SFP36
120/24 VAC Power Supply	0365534PK	ETF-233
120/24 VAC Power Supply (Canada) Plug-in	0365879	ETF-416
120/24 VAC Power Supply (Box Mount)	0345370PK	EL-248-40
Extension Cable	0362017	SFP37
Splitter Cable	0362018	SFP38
Gang Adapter Kit	0362035	SFP35A
Faucet to Module Ext. Cable*	0367113	EFP-113-A



NOTE: Some parts and accessories must be ordered separately
* Not shown

Optima® EBF-85/EBF-187/ETF-80/ETF-880 Faucets Parts & Accessories

TROUBLESHOOTING INSTRUCTIONS FOR OPTIMA SENSOR ACTIVATED LAVATORY FAUCETS WITH THE NEW OPTIMA CONTROL BOXES AND THE SLOAN CONNECT SMARTPHONE APP.

NOTE: To automatically check battery strength, troubleshoot, diagnose and report faucet issues with a wireless device, use the Sloan SmartPhone APP. The APP is available free-of-charge at the Apple iPhone APP store for iOS devices or the Google Play APP store for Android devices. For more information about the APP and its capabilities please visit www.Sloan.com.

FAUCET TROUBLESHOOTING GUIDE

LED indicator light in the IR (infrared) sensor is red.

- A. Battery power is low.
Install four (4) new AA sized alkaline batteries. Check that the orientation of each battery matches the positive (+) and negative (-) symbols shown in the bottom of the battery compartment.
Re-attach battery compartment to control module. Green LED will illuminate. If the Green LED does not illuminate, remove battery compartment for 10 seconds and return into place.

Faucet DOES NOT function.

- A. Batteries not installed or are exhausted.
Install four (4) AA sized alkaline batteries. Check that the orientation of each battery matches the positive (+) and negative (-) symbols shown in the bottom of the battery compartment. Reattach battery compartment to control module. Green LED will illuminate. If the Green LED does not illuminate, remove battery compartment for 10 seconds and return into place.
- B. Power Cable not installed (Hardwire models).
Install power cable and check connection.
- C. Sensor Cable not installed.
Install sensor cable and check connection. Confirm connection guide markings are aligned.
- D. Sensor range is set too short and is not detecting the target.
Increase sensor detection range.

Sensor is activated but faucet DOES NOT deliver water.

- A. Faucet has initiated its adaptive sensing calibration program.
Wait 60 seconds before activating faucet.
- B. Solenoid Cable not connected.
Check solenoid cable connection. Confirm connection guide markings are aligned.

Sensor Range Requires Manual Adjustment.

Sensor Range is measured in units from 1 to 5, with 1 being closest to the faucet and 5 being farthest from the faucet. The factory default Sensor Range is 3.

- A. To determine what the current Sensor Range setting is, press the red "Sensor" button on the upper right hand corner of the Optima Control Box for 1 second. Five seconds after pressing the button, the green LED beside it will blink to indicate the Sensor Range setting. For example, if it is set at 2, the green LED will blink 2 times.
- B. To adjust the Sensor Range, press and hold the red "Sensor" button for three seconds and release once the green LED comes on to indicate that you are in Sensor Range adjustment mode. Then press the "Sensor" button one second at a time for however many times you wish to increase the range. For example, if the Sensor Range is set at 2 and you wish to increase it to 4, press the "Sensor" button two times for one second each time..
- C. If you wish to decrease the Sensor Range, follow the same procedure to enter into Sensor Range adjustment mode, and then press the "Sensor" button one second at a time. The button is designed to go up to 5 units and then back down to 1 unit. For example, if the Sensor Range is set at 4 and you wish to decrease it to 2, press the "Sensor" button three times for one second each time.
- D. To conform your changes, wait 5 seconds and then press the red "Sensor" button on the upper right hand corner of the Optima Control Box for 1 second. Five seconds after pressing the button, the green LED beside it will blink to indicate the Sensor Range setting. For example, if it is now set at 2, the green LED will blink 2 times.

Solenoid produces an audible "CLICK" when an object is placed in the detection zone of the sensor but NO water flows.

- A. Water supply to faucet is not open.
Open supply stop(s).
- B. Inlet fitting filter is clogged.
Remove, clean, and reinsert. Replace with EBF1004 solenoid filter kit if necessary.
- C. Aerator or spray head is clogged.
Remove, clean, and reinsert.

Optima® EBF-85/EBF-187/ETF-80/ETF-880 Faucets Parts & Accessories

Solenoid valve DOES NOT produce an audible “CLICK” and NO water flows. Green LED illuminates when batteries installed.

- A. Replace EFP103A solenoid valve module.

Faucet delivers only a slow flow or dribble when sensor is activated.

- A. Water supply valve is partially closed.
Open the supply stop(s) completely.
- B. Inlet fitting filter is clogged.
Remove, clean, and reinsert. Replace with EFP101A replacement filter kit if necessary.
- C. Aerator or spray head is clogged.
Remove, clean, and reinsert.

Faucet DOES NOT stop delivering water or continues to drip after user is no longer detected (automatic shut-off fails even when batteries are removed).

- A. Solenoid valve seat is dirty.
Remove, clean, and reinsert solenoid filter. Activate faucet several times to flush out dirt.
- B. Sensor range is set too long and is detecting the sink or some other object.
Reduce sensor detection range.
- C. Solenoid valve module is not working properly.
Replace EFP103A solenoid valve module.

The water temperature is too hot or too cold on a faucet connected to hot and cold supply lines with inlet filter fitting.

- A. Supply stops are not adjusted properly.
Adjust supply stops.

NOTE: For some systems, a thermostatic mixing valve may be required

SLOAN CONNECT APP FAQs

How do I connect my faucet to the Sloan mobile app?

To connect your faucet to the Sloan mobile App, you must complete the following steps:

1. Turn on your smartphone's Bluetooth.
2. Open the Sloan mobile app.
3. Complete all Sign In fields and agree to the End User License Agreement and Terms of Use.
4. Activate your faucets Bluetooth transmitter by slowly waving your hand underneath the faucet three (3) times within ten (10) seconds. Note: water will run during this process.
5. When your faucet's Bluetooth transmitter is activated, the Sloan mobile app will display your faucet.
6. Select your faucet to confirm and connect to the Sloan mobile app.

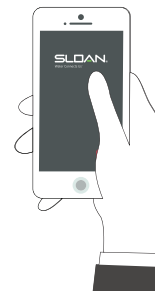

Can I still use my app and faucet if there is no internet connection?

Yes. The Sloan Connect App and faucet are designed to work in offline mode. All connectivity occurs via Bluetooth, which does not require an internet connection. If your phone is running Android 7, there is a built-in feature to prevent abusive BLE scanning. This change prevents an app from stopping and starting BLE scans more than 5 times in a window of 30 seconds. If this app does not detect any faucet and your phone is running Android 7, just exit the app and restart the app 30 seconds later.

My faucet is not showing in advertised devices.

Please be sure your Sloan Optima Control Box has power. To do this, remove the cover with the single screw in the center. Check there are no loose or disconnected wires and ensure the batteries are properly installed. Then repeat the connection process. If you are still experiencing issues, contact Sloan.

How do I save and load settings?

Each time you update settings on a faucet, they are stored in the app. If you would like to load the settings from a previous faucet to a new faucet, connect to that faucet and select the "Load Previous Settings". This will display a dialogue box showing the previous settings. Click "Confirm" to load those settings into the app, then select "Apply Settings To Faucet" button at the bottom of your dashboard.

Why is the dashboard photo of my faucet not correct?

Each Sloan faucet type has several images associated with it. Use the left and right arrows to view the different faucet images.

How can I use the Sloan Connect App to save information about a specific faucet, like its location?

Select the "Notes" option from the main App screen and use this feature to include up to 120 characters worth of information.

When assistance is required, please contact Sloan Technical Support at:

1-888-SLOAN-14 (1-888-756-2614) (USA only) or +1-847-671-4300 (all other locations),
or visit sloan.com

Optima® EBF-650/ETF-600 Faucets

Parts & Accessories



ETF-600 Low-height, hardwired
EBF-650 Low-height, battery

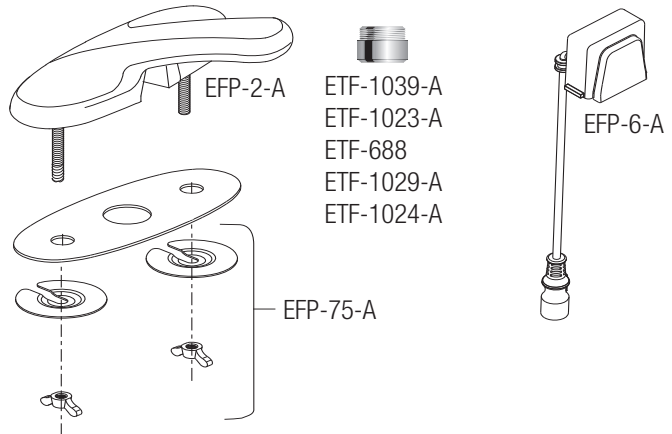

ETF-1039-A
 ETF-1023-A
 ETF-688
 ETF-1029-A
 ETF-1024-A

ETP-6-A

ETP-75-A

SPOUT ASSEMBLY

Description	Code No.	Part No.
Spout Assembly	0367002	EFP-2-A
Sensor & Cable Assembly	0367006	EFP-6-A
Sensor & Cable Assembly	0367075	EFP-75-A

SPRAYHEAD OPTIONS

Description	Type	Code No.	Part No.
0.35 GPM/1.3 Lpm	MLM	3365756	ETF-1039-A
0.5 GPM/1.9 Lpm	MLM	3365092	ETF-1023-A
1.5 GPM/5.7 Lpm	LAM	0365395	ETF-688
2.2 GPM/8.3 Lpm	LAM	3365162	ETF-1029-A
2.2 GPM/8.3 Lpm	AER	3365093	ETF-1024-A

TRIMPLATE OPTIONS

Description	Code No.	Part No.
8"	3365114	ETF-578-A

BELOW DECK ASSEMBLIES

Description	Code No.	Part No.
Control Box No Turbine	0367039	EFP-39-A
Control Box Turbine 0.5 gpm	0367040	EFP-40-A
Control Box Turbine 1.5 gpm	0367011	EFP-11-A
Quick Connect Spout Hose 24"	0367025	EFP-25
Control Box Cover w/Screw	0367010	EFP-10-A
Solenoid Assembly	0367103	EFP-103-A
Battery Pack	3324113	EFX-8-A
Double Inlet Tee Filter Assembly	0367028	EFP-28-A
BDM & Single Inlet Tee Filter Assembly Kit	0367099	EFP-99-A
BDT & Single Inlet Tee Filter Assembly Kit	0367100	EFP-100-A
Replacement Filter Pack-(5) Filter (5) Large O-rings (5) Small O-rings	0367101	EFP-101-A
24 VAC Power Harness Assembly	0367098	EFP-98-A
110V/6 VDC Power Supply	0362006	SFP-6
100/240VAC/6 VDC Power Supply	0362016	SFP-36
120/24 VAC Power Supply	0365534PK	ETF-233
120/24 VAC Power Supply (Canada) Plug-in	0365879	ETF-416
120/24 VAC Power Supply (Box Mount)	0345370PK	EL-248-40
Extension Cable	0362017	SFP-37
Splitter Cable	0362018	SFP-38
Gang Adapter Kit	0362035	SFP-35-A
Faucet to Module Ext. Cable*	0367113	EFP-113-A

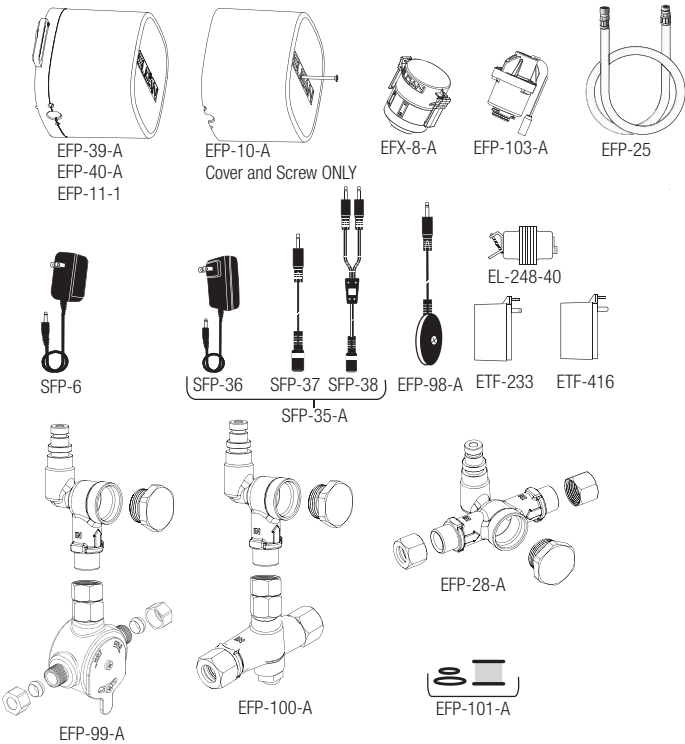

EFP-39-A
 EFP-40-A
 EFP-11-1

EFP-10-A
 Cover and Screw ONLY

EFX-8-A

EFP-103-A

EFP-25

SFP-6

SFP-36

SFP-37

SFP-38

EFP-98-A

ETF-233

ETF-416

SFP-35-A

EFP-28-A

EFP-99-A

EFP-100-A

EFP-101-A

NOTE: Some parts and accessories must be ordered separately.

* Not shown

Optima® EBF-650/ETF-600 Faucets

Parts & Accessories

TROUBLESHOOTING INSTRUCTIONS FOR OPTIMA SENSOR ACTIVATED LAVATORY FAUCETS WITH THE NEW OPTIMA CONTROL BOXES AND THE SLOAN CONNECT SMARTPHONE APP.

NOTE: To automatically check battery strength, troubleshoot, diagnose and report faucet issues with a wireless device, use the Sloan SmartPhone APP. The APP is available free-of-charge at the Apple iPhone APP store for iOS devices or the Google Play APP store for Android devices. For more information about the APP and its capabilities please visit www.Sloan.com.

FAUCET TROUBLESHOOTING GUIDE

LED indicator light in the IR (infrared) sensor is red.

- A. Battery power is low.
Install four (4) new AA sized alkaline batteries. Check that the orientation of each battery matches the positive (+) and negative (-) symbols shown in the bottom of the battery compartment.
Re-attach battery compartment to control module. Green LED will illuminate. If the Green LED does not illuminate, remove battery compartment for 10 seconds and return into place.

Faucet DOES NOT function.

- A. Batteries not installed or are exhausted.
Install four (4) AA sized alkaline batteries. Check that the orientation of each battery matches the positive (+) and negative (-) symbols shown in the bottom of the battery compartment. Reattach battery compartment to control module. Green LED will illuminate. If the Green LED does not illuminate, remove battery compartment for 10 seconds and return into place.
- B. Power Cable not installed (Hardwire models).
Install power cable and check connection.
- C. Sensor Cable not installed.
Install sensor cable and check connection. Confirm connection guide markings are aligned.
- D. Sensor range is set too short and is not detecting the target.
Increase sensor detection range.

Sensor is activated but faucet DOES NOT deliver water.

- A. Faucet has initiated its adaptive sensing calibration program.
Wait 60 seconds before activating faucet.
- B. Solenoid Cable not connected.
Check solenoid cable connection. Confirm connection guide markings are aligned.

Sensor Range Requires Manual Adjustment.

Sensor Range is measured in units from 1 to 5, with 1 being closest to the faucet and 5 being farthest from the faucet. The factory default Sensor Range is 3.

- A. To determine what the current Sensor Range setting is, press the red "Sensor" button on the upper right hand corner of the Optima Control Box for 1 second. Five seconds after pressing the button, the green LED beside it will blink to indicate the Sensor Range setting. For example, if it is set at 2, the green LED will blink 2 times.
- B. To adjust the Sensor Range, press and hold the red "Sensor" button for three seconds and release once the green LED comes on to indicate that you are in Sensor Range adjustment mode. Then press the "Sensor" button one second at a time for however many times you wish to increase the range. For example, if the Sensor Range is set at 2 and you wish to increase it to 4, press the "Sensor" button two times for one second each time..
- C. If you wish to decrease the Sensor Range, follow the same procedure to enter into Sensor Range adjustment mode, and then press the "Sensor" button one second at a time. The button is designed to go up to 5 units and then back down to 1 unit. For example, if the Sensor Range is set at 4 and you wish to decrease it to 2, press the "Sensor" button three times for one second each time.
- D. To conform your changes, wait 5 seconds and then press the red "Sensor" button on the upper right hand corner of the Optima Control Box for 1 second. Five seconds after pressing the button, the green LED beside it will blink to indicate the Sensor Range setting. For example, if it is now set at 2, the green LED will blink 2 times.

Solenoid produces an audible "CLICK" when an object is placed in the detection zone of the sensor but NO water flows.

- A. Water supply to faucet is not open.
Open supply stop(s).
- B. Inlet fitting filter is clogged.
Remove, clean, and reinsert. Replace with EBF1004 solenoid filter kit if necessary.
- C. Aerator or spray head is clogged.
Remove, clean, and reinsert.

Optima® EBF-650/ETF-600 Faucets

Parts & Accessories

Solenoid valve DOES NOT produce an audible “CLICK” and NO water flows. Green LED illuminates when batteries installed.

- A. Replace EFP103A solenoid valve module.

Faucet delivers only a slow flow or dribble when sensor is activated.

- A. Water supply valve is partially closed.
Open the supply stop(s) completely.
- B. Inlet fitting filter is clogged.
Remove, clean, and reinsert. Replace with EFP101A replacement filter kit if necessary.
- C. Aerator or spray head is clogged.
Remove, clean, and reinsert.

Faucet DOES NOT stop delivering water or continues to drip after user is no longer detected (automatic shut-off fails even when batteries are removed).

- A. Solenoid valve seat is dirty.
Remove, clean, and reinsert solenoid filter. Activate faucet several times to flush out dirt.
- B. Sensor range is set too long and is detecting the sink or some other object.
Reduce sensor detection range.
- C. Solenoid valve module is not working properly.
Replace EFP103A solenoid valve module.

The water temperature is too hot or too cold on a faucet connected to hot and cold supply lines with inlet filter fitting.

- A. Supply stops are not adjusted properly.
Adjust supply stops.

NOTE: For some systems, a thermostatic mixing valve may be required

SLOAN CONNECT APP FAQs

How do I connect my faucet to the Sloan mobile app?

To connect your faucet to the Sloan mobile App, you must complete the following steps:

1. Turn on your smartphone's Bluetooth.
2. Open the Sloan mobile app.
3. Complete all Sign In fields and agree to the End User License Agreement and Terms of Use.
4. Activate your faucets Bluetooth transmitter by slowly waving your hand underneath the faucet three (3) times within ten (10) seconds. Note: water will run during this process.
5. When your faucet's Bluetooth transmitter is activated, the Sloan mobile app will display your faucet.
6. Select your faucet to confirm and connect to the Sloan mobile app.

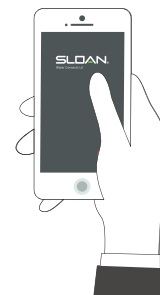

Can I still use my app and faucet if there is no internet connection?

Yes. The Sloan Connect App and faucet are designed to work in offline mode. All connectivity occurs via Bluetooth, which does not require an internet connection. If your phone is running Android 7, there is a built-in feature to prevent abusive BLE scanning. This change prevents an app from stopping and starting BLE scans more than 5 times in a window of 30 seconds. If this app does not detect any faucet and your phone is running Android 7, just exit the app and restart the app 30 seconds later.

My faucet is not showing in advertised devices.

Please be sure your Sloan Optima Control Box has power. To do this, remove the cover with the single screw in the center. Check there are no loose or disconnected wires and ensure the batteries are properly installed. Then repeat the connection process. If you are still experiencing issues, contact Sloan.

How do I save and load settings?

Each time you update settings on a faucet, they are stored in the app. If you would like to load the settings from a previous faucet to a new faucet, connect to that faucet and select the “Load Previous Settings”. This will display a dialogue box showing the previous settings. Click “Confirm” to load those settings into the app, then select “Apply Settings To Faucet” button at the bottom of your dashboard.

Why is the dashboard photo of my faucet not correct?

Each Sloan faucet type has several images associated with it. Use the left and right arrows to view the different faucet images.

How can I use the Sloan Connect App to save information about a specific faucet, like its location?

Select the “Notes” option from the main App screen and use this feature to include up to 120 characters worth of information.

When assistance is required, please contact Sloan Technical Support at:
1-888-SLOAN-14 (1-888-756-2614) (USA only) or +1-847-671-4300 (all other locations),
or visit sloan.com

Optima® EBF-615/ETF-610 Faucets

Parts & Accessories



ETF-610 Low-height, hardwired
EBF-615 Low-height, battery

SPOUT ASSEMBLY

Description	Code No.	Part No.
Spout Assembly ETF-610/EBF-615	0367003	EFP-3-A
Sensor & Cable Assembly	0367006	EFP-6-A
Spout Mounting Kit	0367074	EFP-74-A

SPRAYHEAD OPTIONS

Description	Type	Code No.	Part No.
0.35 GPM/1.3 Lpm	MLM	3365756	ETF-1039-A
0.5 GPM/1.9 Lpm	MLM	3365092	ETF-1023-A
1.5 GPM/5.7 Lpm	LAM	0365395	ETF-688
2.2 GPM/8.3 Lpm	LAM	3365162	ETF-1029-A
2.2 GPM/8.3 Lpm	AER	3365162	ETF-1024-A

TRIMPLATE OPTIONS

Description	Code No.	Part No.
4"	3365302	ETF-607-A
8"	3365303	ETF-608-A

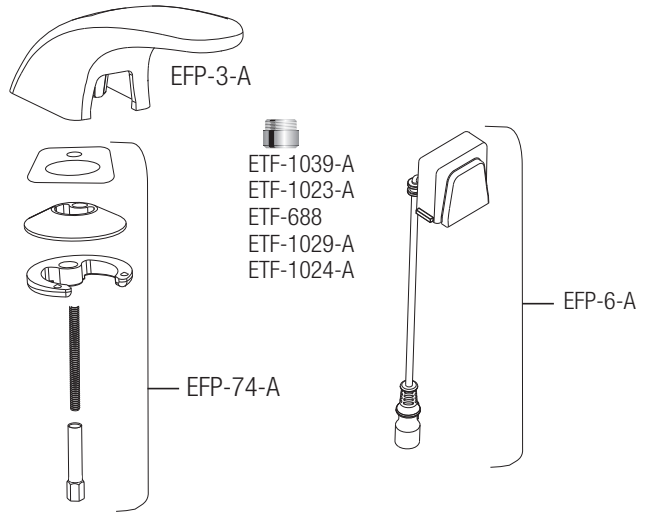

BELOW DECK ASSEMBLIES

Description	Code No.	Part No.
Control Box No Turbine	0367039	EFP-39-A
Control Box Turbine 0.5 gpm	0367040	EFP-40-A
Control Box Turbine 1.5 gpm	0367011	EFP-11-A
Quick Connect Spout Hose 24"	0367025	EFP-25-A
Control Box Cover w/Screw	0367010	EFP-10-A
Solenoid Assembly	0367103	EFP-103-A
Battery Pack	3324113	EFX-8-A
Double Inlet Tee Filter Assembly	0367028	EFP-28-A
BDM & Single Inlet Tee Filter Assembly Kit	0367099	EFP-99-A
BDT & Single Inlet Tee Filter Assembly Kit	0367100	EFP-100-A
Replacement Filter Pack-(5) Filter (5) Large O-rings (5) Small O-rings	0367101	EFP-101-A
24 VAC Power Harness Assembly	0367098	EFP-98-A
110V/6 VDC Power Supply	0362006	SFP-6
100-240 VAC/6VDC Power Supply	0362016	SFP-36
120/24 VAC Power Supply	0365534PK	ETF-233
120/24 VAC Power Supply (Canada) Plug-in	0365879	ETF-416
120/24 VAC Power Supply (Box Mount)	0345370PK	EL-248-40
Extension Cable	0362017	SFP-37
Splitter Cable	0362018	SFP-38
Gang Adapter Kit	0362035	SFP-35-A
Faucet to Module Ext. Cable*	0367113	EFP-113-A

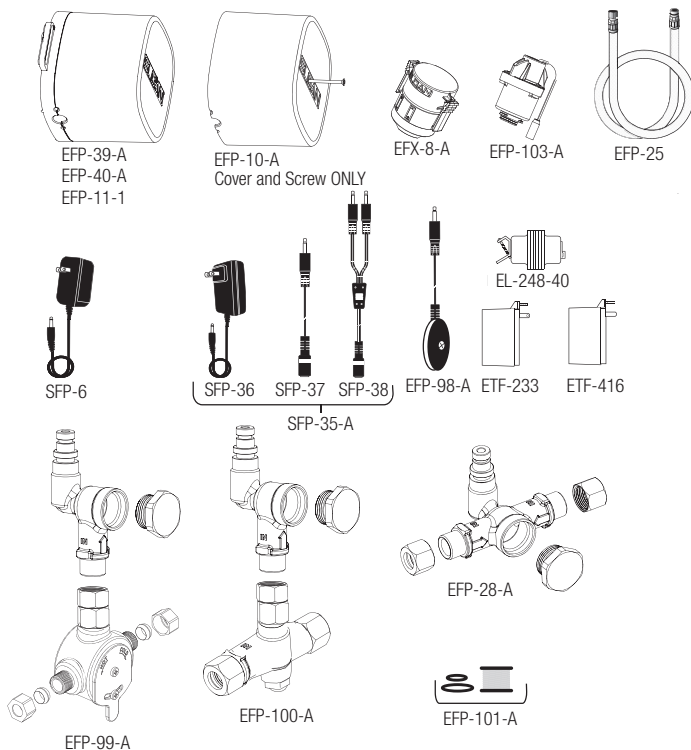

NOTE: Some parts and accessories must be ordered separately.

* Not shown

Optima® EBF-615/ETF-610 Faucets

Parts & Accessories

TROUBLESHOOTING INSTRUCTIONS FOR OPTIMA SENSOR ACTIVATED LAVATORY FAUCETS WITH THE NEW OPTIMA CONTROL BOXES AND THE SLOAN CONNECT SMARTPHONE APP.

NOTE: To automatically check battery strength, troubleshoot, diagnose and report faucet issues with a wireless device, use the Sloan SmartPhone APP. The APP is available free-of-charge at the Apple iPhone APP store for iOS devices or the Google Play APP store for Android devices. For more information about the APP and its capabilities please visit www.Sloan.com.

FAUCET TROUBLESHOOTING GUIDE

LED indicator light in the IR (infrared) sensor is red.

- A. Battery power is low.
Install four (4) new AA sized alkaline batteries. Check that the orientation of each battery matches the positive (+) and negative (-) symbols shown in the bottom of the battery compartment.
Re-attach battery compartment to control module. Green LED will illuminate. If the Green LED does not illuminate, remove battery compartment for 10 seconds and return into place.

Faucet DOES NOT function.

- A. Batteries not installed or are exhausted.
Install four (4) AA sized alkaline batteries. Check that the orientation of each battery matches the positive (+) and negative (-) symbols shown in the bottom of the battery compartment. Reattach battery compartment to control module. Green LED will illuminate. If the Green LED does not illuminate, remove battery compartment for 10 seconds and return into place.
- B. Power Cable not installed (Hardwire models).
Install power cable and check connection.
- C. Sensor Cable not installed.
Install sensor cable and check connection. Confirm connection guide markings are aligned.
- D. Sensor range is set too short and is not detecting the target.
Increase sensor detection range.

Sensor is activated but faucet DOES NOT deliver water.

- A. Faucet has initiated its adaptive sensing calibration program.
Wait 60 seconds before activating faucet.
- B. Solenoid Cable not connected.
Check solenoid cable connection. Confirm connection guide markings are aligned.

Sensor Range Requires Manual Adjustment.

Sensor Range is measured in units from 1 to 5, with 1 being closest to the faucet and 5 being farthest from the faucet. The factory default Sensor Range is 3.

- A. To determine what the current Sensor Range setting is, press the red "Sensor" button on the upper right hand corner of the Optima Control Box for 1 second. Five seconds after pressing the button, the green LED beside it will blink to indicate the Sensor Range setting. For example, if it is set at 2, the green LED will blink 2 times.
- B. To adjust the Sensor Range, press and hold the red "Sensor" button for three seconds and release once the green LED comes on to indicate that you are in Sensor Range adjustment mode. Then press the "Sensor" button one second at a time for however many times you wish to increase the range. For example, if the Sensor Range is set at 2 and you wish to increase it to 4, press the "Sensor" button two times for one second each time..
- C. If you wish to decrease the Sensor Range, follow the same procedure to enter into Sensor Range adjustment mode, and then press the "Sensor" button one second at a time. The button is designed to go up to 5 units and then back down to 1 unit. For example, if the Sensor Range is set at 4 and you wish to decrease it to 2, press the "Sensor" button three times for one second each time.
- D. To conform your changes, wait 5 seconds and then press the red "Sensor" button on the upper right hand corner of the Optima Control Box for 1 second. Five seconds after pressing the button, the green LED beside it will blink to indicate the Sensor Range setting. For example, if it is now set at 2, the green LED will blink 2 times.

Solenoid produces an audible "CLICK" when an object is placed in the detection zone of the sensor but NO water flows.

- A. Water supply to faucet is not open.
Open supply stop(s).
- B. Inlet fitting filter is clogged.
Remove, clean, and reinsert. Replace with EBF1004 solenoid filter kit if necessary.
- C. Aerator or spray head is clogged.
Remove, clean, and reinsert.

Optima® EBF-615/ETF-610 Faucets

Parts & Accessories

Solenoid valve DOES NOT produce an audible “CLICK” and NO water flows. Green LED illuminates when batteries installed.

- A. Solenoid valve module is not working properly.
Replace EFP103A solenoid valve module.

Faucet delivers only a slow flow or dribble when sensor is activated.

- A. Water supply valve is partially closed.
Open the supply stop(s) completely.
- B. Inlet fitting filter is clogged.
Remove, clean, and reinsert. Replace with EFP101A replacement filter kit if necessary.
- C. Aerator or spray head is clogged.
Remove, clean, and reinsert.

Faucet DOES NOT stop delivering water or continues to drip after user is no longer detected (automatic shut-off fails even when batteries are removed).

- A. Solenoid valve seat is dirty.
Remove, clean, and reinsert solenoid filter. Activate faucet several times to flush out dirt.
- B. Sensor range is set too long and is detecting the sink or some other object.
Reduce sensor detection range.
- C. Solenoid valve module is not working properly.
Replace EFP103A solenoid valve module.

The water temperature is too hot or too cold on a faucet connected to hot and cold supply lines with inlet filter fitting.

- A. Supply stops are not adjusted properly.
Adjust supply stops.

NOTE: For some systems, a thermostatic mixing valve may be required

SLOAN CONNECT APP FAQs

How do I connect my faucet to the Sloan mobile app?

To connect your faucet to the Sloan mobile App, you must complete the following steps:

1. Turn on your smartphone's Bluetooth.
2. Open the Sloan mobile app.
3. Complete all Sign In fields and agree to the End User License Agreement and Terms of Use.
4. Activate your faucets Bluetooth transmitter by slowly waving your hand underneath the faucet three (3) times within ten (10) seconds. Note: water will run during this process.
5. When your faucets Bluetooth transmitter is activated, the Sloan mobile app will display your faucet.
6. Select your faucet to confirm and connect to the Sloan mobile app.

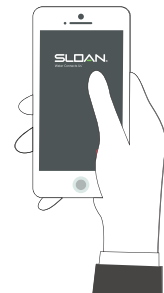

Can I still use my app and faucet if there is no internet connection?

Yes. The Sloan Connect App and faucet are designed to work in offline mode. All connectivity occurs via Bluetooth, which does not require an internet connection. If your phone is running Android 7, there is a built-in feature to prevent abusive BLE scanning. This change prevents an app from stopping and starting BLE scans more than 5 times in a window of 30 seconds. If this app does not detect any faucet and your phone is running Android 7, just exit the app and restart the app 30 seconds later.

My faucet is not showing in advertised devices.

Please be sure your Sloan Optima Control Box has power. To do this, remove the cover with the single screw in the center. Check there are no loose or disconnected wires and ensure the batteries are properly installed. Then repeat the connection process. If you are still experiencing issues, contact Sloan.

How do I save and load settings?

Each time you update settings on a faucet, they are stored in the app. If you would like to load the settings from a previous faucet to a new faucet, connect to that faucet and select the “Load Previous Settings”. This will display a dialogue box showing the previous settings. Click “Confirm” to load those settings into the app, then select “Apply Settings To Faucet” button at the bottom of your dashboard.

Why is the dashboard photo of my faucet not correct?

Each Sloan faucet type has several images associated with it. Use the left and right arrows to view the different faucet images.

How can I use the Sloan Connect App to save information about a specific faucet, like its location?

Select the “Notes” option from the main App screen and use this feature to include up to 120 characters worth of information.

When assistance is required, please contact Sloan Technical Support at:
1-888-SLOAN-14 (1-888-756-2614) (USA only) or +1-847-671-4300 (all other locations),
or visit sloan.com

Optima® EBF-750/EBF-750-S/ETF-700

ETF-700-S Faucets Parts & Accessories



ETF-700 Deck mount, hardwired
ETF-700-S Deck mount, hardwired
EBF-750 Deck mount, battery
EBF-750-S Deck mount, battery

SPOUT ASSEMBLY

Description	Code No	Part No.
Spout Assembly ETF-700/EBF-750	0367085	EFP-85-A
Spout Assembly ETF-700-S/EBF-750-S	0367094	EFP-94-A
Sensor & Cable Assembly	0367081	EFP-81-A
Spout Mounting Assembly	0365110	ETF-503-A

SPRAYHEAD OPTIONS

Description	Type	Code	Part No.
0.35 GPM/1.3 Lpm	MLM	0365793	ETF-839
0.5 GPM/1.9 Lpm	MLM	0365420	ETF-801
1.0 GPM/3.8 Lpm	MLM	0365454	ETF-852
1.5 GPM/5.7 Lpm	LAM	0365387	ETF-687
1.5 GPM/5.7 Lpm	Shower	0328134	AC-55-A
2.2 GPM/8.3 Lpm	LAM	0365147	ETF-621
Aerator Adapter (not required for shower spray head)		0305784	ETF-178

TRIMPLATE OPTIONS

Description	Code No.	Part No.
4"	3365302	ETF-607-A
8"	3365303	ETF-608-A

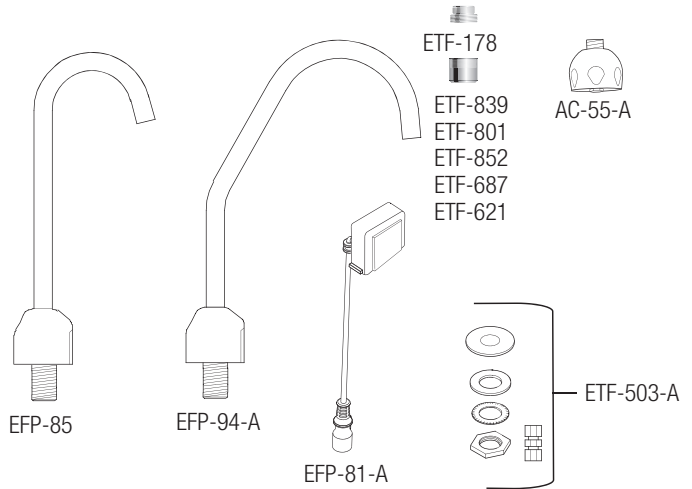
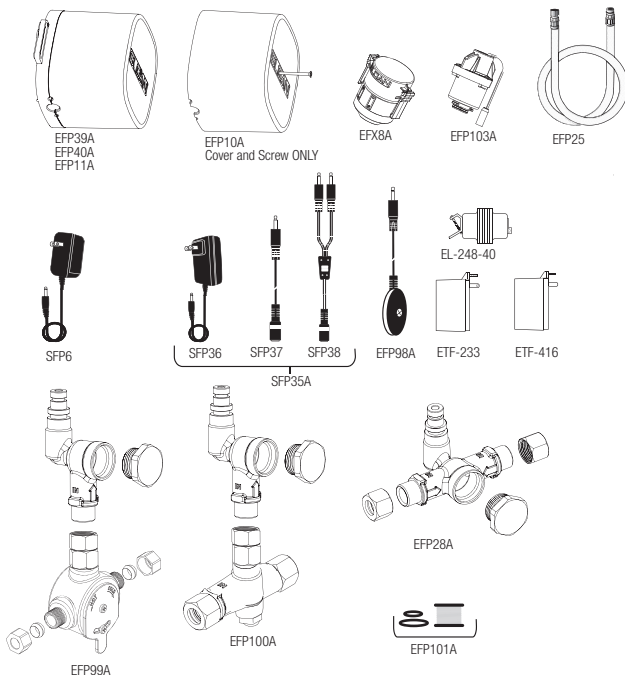

BELOW DECK ASSEMBLIES

Description	Code No.	Part No.
Control Box No Turbine	0367039	EFP-39-A
Control Box Turbine 0.5 gpm	0367040	EFP-40-A
Control Box Turbine 1.5 gpm	0367011	EFP-11-A
Quick Connect Spout Hose 18"	0324034	EFX-34
Control Box Cover w/Screw	0367010	EFP-10-A
Solenoid Assembly	0367103	EFP-103-A
Battery Pack	3324113	EFX-8-A
Double Inlet Tee Filter Assembly	0367028	EFP-28-A
BDM & Single Inlet Tee Filter Assembly Kit	0367099	EFP-99-A
BDT & Single Inlet Tee Filter Assembly Kit	0367100	EFP-100-A
Replacement Filter Pack-(5) Filter (5) Large O-rings (5) Small O-rings	0367101	EFP-101-A
24 VAC Power Harness Assembly	0367098	EFP-98-A
110V/6VDC Power Supply	0362006	SFP-6
100/240VAC/6 VDC Power Supply	0362016	SFP-36
120/24 VAC Power Supply	0365534PK	ETF-233
120/24 VAC Power Supply (Canada) Plug-in	0365879	ETF-416
120/24 VAC Power Supply (Box Mount)	0345370PK	EL-248-40
Extension Cable	0362017	SFP-37
Splitter Cable	0362018	SFP-38
Gang Adapter Kit	0362035	SFP-35-A
Faucet to Module Ext. Cable*	0367113	EFP-113-A

NOTE: Some parts and accessories must be ordered separately.

* Not shown

Optima® EBF-750/EBF-750-S/ETF-700**ETF 700-S Faucets Parts & Accessories****TROUBLESHOOTING INSTRUCTIONS FOR OPTIMA SENSOR ACTIVATED LAVATORY FAUCETS
WITH THE NEW OPTIMA CONTROL BOXES AND THE SLOAN CONNECT SMARTPHONE APP.**

NOTE: To automatically check battery strength, troubleshoot, diagnose and report faucet issues with a wireless device, use the Sloan SmartPhone APP. The APP is available free-of-charge at the Apple iPhone APP store for iOS devices or the Google Play APP store for Android devices. For more information about the APP and its capabilities please visit www.Sloan.com.

FAUCET TROUBLESHOOTING GUIDE**LED indicator light in the IR (infrared) sensor is red.**

- A. Battery power is low.
Install four (4) new AA sized alkaline batteries. Check that the orientation of each battery matches the positive (+) and negative (-) symbols shown in the bottom of the battery compartment.
Re-attach battery compartment to control module. Green LED will illuminate. If the Green LED does not illuminate, remove battery compartment for 10 seconds and return into place.

Faucet DOES NOT function.

- A. Batteries not installed or are exhausted.
Install four (4) AA sized alkaline batteries. Check that the orientation of each battery matches the positive (+) and negative (-) symbols shown in the bottom of the battery compartment. Reattach battery compartment to control module. Green LED will illuminate. If the Green LED does not illuminate, remove battery compartment for 10 seconds and return into place.
- B. Power Cable not installed (Hardwire models).
Install power cable and check connection.
- C. Sensor Cable not installed.
Install sensor cable and check connection. Confirm connection guide markings are aligned.
- D. Sensor range is set too short and is not detecting the target.
Increase sensor detection range.

Sensor is activated but faucet DOES NOT deliver water.

- A. Faucet has initiated its adaptive sensing calibration program.
Wait 60 seconds before activating faucet.
- B. Solenoid Cable not connected.
Check solenoid cable connection. Confirm connection guide markings are aligned.

Sensor Range Requires Manual Adjustment.

Sensor Range is measured in units from 1 to 5, with 1 being closest to the faucet and 5 being farthest from the faucet. The factory default Sensor Range is 3.

- A. To determine what the current Sensor Range setting is, press the red "Sensor" button on the upper right hand corner of the Optima Control Box for 1 second. Five seconds after pressing the button, the green LED beside it will blink to indicate the Sensor Range setting. For example, if it is set at 2, the green LED will blink 2 times.
- B. To adjust the Sensor Range, press and hold the red "Sensor" button for three seconds and release once the green LED comes on to indicate that you are in Sensor Range adjustment mode. Then press the "Sensor" button one second at a time for however many times you wish to increase the range. For example, if the Sensor Range is set at 2 and you wish to increase it to 4, press the "Sensor" button two times for one second each time..
- C. If you wish to decrease the Sensor Range, follow the same procedure to enter into Sensor Range adjustment mode, and then press the "Sensor" button one second at a time. The button is designed to go up to 5 units and then back down to 1 unit. For example, if the Sensor Range is set at 4 and you wish to decrease it to 2, press the "Sensor" button three times for one second each time.
- D. To conform your changes, wait 5 seconds and then press the red "Sensor" button on the upper right hand corner of the Optima Control Box for 1 second. Five seconds after pressing the button, the green LED beside it will blink to indicate the Sensor Range setting. For example, if it is now set at 2, the green LED will blink 2 times.

**Solenoid produces an audible "CLICK" when an object is placed in the detection zone of the sensor but
NO water flows.**

- A. Water supply to faucet is not open.
Open supply stop(s).
- B. Inlet fitting filter is clogged.
Remove, clean, and reinsert. Replace with EBF1004 solenoid filter kit if necessary.
- C. Aerator or spray head is clogged.
Remove, clean, and reinsert.

Optima® EBF-750/EBF-750-S/ETF-700**ETF 700-S Faucets Parts & Accessories**

Solenoid valve DOES NOT produce an audible “CLICK” and NO water flows. Green LED illuminates when batteries installed.

- A. Solenoid valve module is not working properly.
Replace EFP103A solenoid valve module.

Faucet delivers only a slow flow or dribble when sensor is activated.

- A. Water supply valve is partially closed.
Open the supply stop(s) completely.
- B. Inlet fitting filter is clogged.
Remove, clean, and reinsert. Replace with EFP101A replacement filter kit if necessary.
- C. Aerator or spray head is clogged.
Remove, clean, and reinsert.

Faucet DOES NOT stop delivering water or continues to drip after user is no longer detected (automatic shut-off fails even when batteries are removed).

- A. Solenoid valve seat is dirty.
Remove, clean, and reinsert solenoid filter. Activate faucet several times to flush out dirt.
- B. Sensor range is set too long and is detecting the sink or some other object.
Reduce sensor detection range.
- C. Solenoid valve module is not working properly.
Replace EFP103A solenoid valve module.

The water temperature is too hot or too cold on a faucet connected to hot and cold supply lines with inlet filter fitting.

- A. Supply stops are not adjusted properly.
Adjust supply stops.

NOTE: For some systems, a thermostatic mixing valve may be required

SLOAN CONNECT APP FAQs

How do I connect my faucet to the Sloan mobile app?

To connect your faucet to the Sloan mobile App, you must complete the following steps:

1. Turn on your smartphone's Bluetooth.
2. Open the Sloan mobile app.
3. Complete all Sign In fields and agree to the End User License Agreement and Terms of Use.
4. Activate your faucets Bluetooth transmitter by slowly waving your hand underneath the faucet three (3) times within ten (10) seconds. Note: water will run during this process.
5. When your faucets Bluetooth transmitter is activated, the Sloan mobile app will display your faucet.
6. Select your faucet to confirm and connect to the Sloan mobile app.

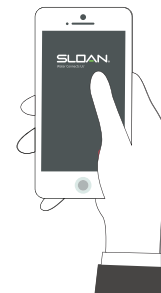

Can I still use my app and faucet if there is no internet connection?

Yes. The Sloan Connect App and faucet are designed to work in offline mode. All connectivity occurs via Bluetooth, which does not require an internet connection. If your phone is running Android 7, there is a built-in feature to prevent abusive BLE scanning. This change prevents an app from stopping and starting BLE scans more than 5 times in a window of 30 seconds. If this app does not detect any faucet and your phone is running Android 7, just exit the app and restart the app 30 seconds later.

My faucet is not showing in advertised devices.

Please be sure your Sloan Optima Control Box has power. To do this, remove the cover with the single screw in the center. Check there are no loose or disconnected wires and ensure the batteries are properly installed. Then repeat the connection process. If you are still experiencing issues, contact Sloan.

How do I save and load settings?

Each time you update settings on a faucet, they are stored in the app. If you would like to load the settings from a previous faucet to a new faucet, connect to that faucet and select the “Load Previous Settings”. This will display a dialogue box showing the previous settings. Click “Confirm” to load those settings into the app, then select “Apply Settings To Faucet” button at the bottom of your dashboard.

Why is the dashboard photo of my faucet not correct?

Each Sloan faucet type has several images associated with it. Use the left and right arrows to view the different faucet images.

How can I use the Sloan Connect App to save information about a specific faucet, like its location?

Select the “Notes” option from the main App screen and use this feature to include up to 120 characters worth of information.

When assistance is required, please contact Sloan Technical Support at:

1-888-SLOAN-14 (1-888-756-2614) (USA only) or +1-847-671-4300 (all other locations), or visit sloan.com

Optima® EBF-550/EBF-550-S/ETF-500

ETF-500-S Faucets Parts & Accessories



ETF-500 Wall mount, hardwired
ETF-500-S Wall mount, hardwired
EBF-550 Wall mount, battery
EBF-550-S Wall mount, battery

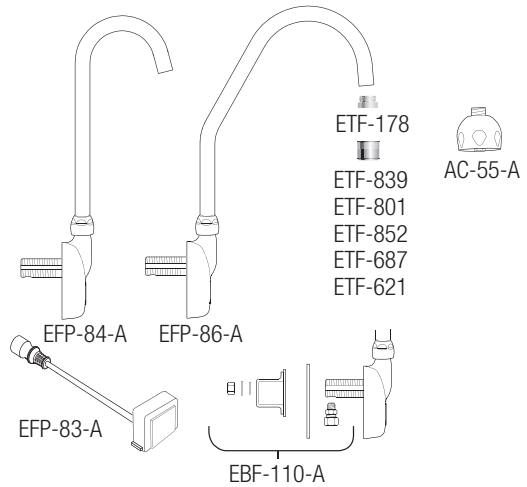

SPOUT ASSEMBLY

Description	Code No.	Part No.
Spout Assembly ETF-500/EBF-550	0367084	EFP-84-A
Spout Assembly ETF-500-S/EBF-550-S	0367086	EFP-86-A
Sensor & Cable Assembly	0367083	EFP-83-A
Spout Mounting Assembly	0315060	EBF-110-A

SPRAYHEAD OPTIONS

Description	Type	Code No.	Part No.
0.35 GPM/1.3 Lpm	MLM	0365793	ETF-839
0.5 GPM/1.9 Lpm	MLM	0365420	ETF-801
1.0 GPM/3.8 Lpm	MLM	0365454	ETF-852
1.5 GPM/5.7 Lpm	LAM	0365387	ETF-687
1.5 GPM/5.7 Lpm	Shower	0328134	AC-55-A
2.2 GPM/8.3 Lpm	LAM	0365147	ETF-621
Aerator Adapter (not required for shower spray head)		0305784	ETF-178

BELOW DECK ASSEMBLIES

Description	Code No.	Part No.
Control Box No Turbine	0367039	EFP-39-A
Control Box Turbine 0.5 gpm	0367040	EFP-40-A
Control Box Turbine 1.5 gpm	0367011	EFP-11-A
Quick Connect Spout Hose 36"	0367104	EFP-104-A
Control Box Cover w/Screw	0367010	EFP-10-A
Solenoid Assembly	0367103	EFP-103-A
Battery Pack	3324113	EFX-8-A
Double Inlet Tee Filter Assembly	0367028	EFP-28-A
BDM & Single Inlet Tee Filter Assembly Kit	0367099	EFP-99-A
BDT & Single Inlet Tee Filter Assembly Kit	0367100	EFP-100-A
Replacement Filter Pack-(5) Filter (5) Large O-rings (5) Small O-rings	0367101	EFP-101-A
24 VAC Power Harness Assembly	0367098	EFP-98-A
110V/6 VDC Power Supply	0362006	SFP-6
100-240 VAC/6 VDC Power Supply	0362016	SFP-36
120/24 VAC Power Supply	0365534PK	ETF-233
120/24 VAC Power Supply (Canada) Plug-in	0365879	ETF-416
120/24 VAC Power Supply (Box Mount)	0345370PK	EL-248-40
Extension Cable	0362017	SFP-37
Splitter Cable	0362018	SFP-38
Gang Adapter Kit	0362035	SFP-35-A
Faucet to Module Ext. Cable*	0367113	EFP-113-A

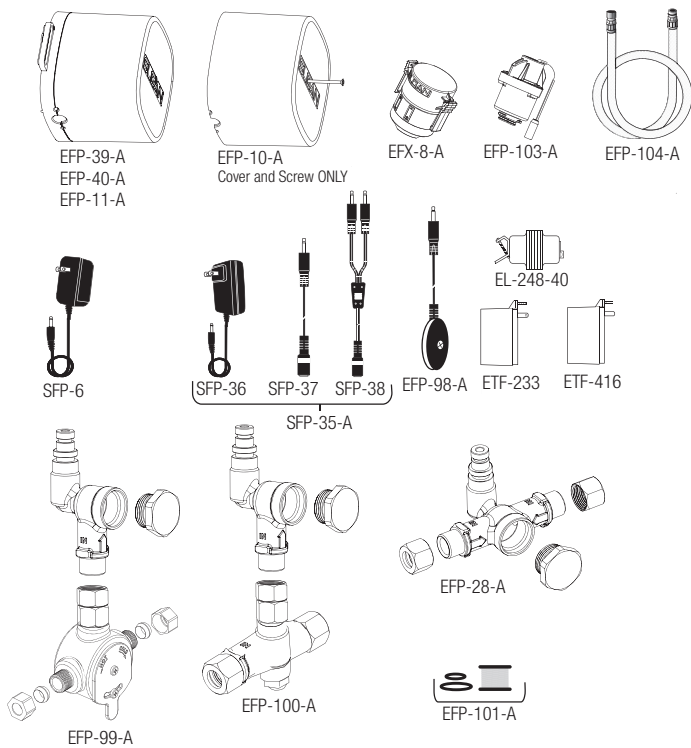

NOTE: Some parts and accessories must be ordered separately.

*Not Shown

Optima® EBF-550/EBF-550-S/ETF-500**ETF-500-S Faucets Parts & Accessories****TROUBLESHOOTING INSTRUCTIONS FOR OPTIMA SENSOR ACTIVATED LAVATORY FAUCETS
WITH THE NEW OPTIMA CONTROL BOXES AND THE SLOAN CONNECT SMARTPHONE APP.**

NOTE: To automatically check battery strength, troubleshoot, diagnose and report faucet issues with a wireless device, use the Sloan SmartPhone APP. The APP is available free-of-charge at the Apple iPhone APP store for iOS devices or the Google Play APP store for Android devices. For more information about the APP and its capabilities please visit Sloan.com.

FAUCET TROUBLESHOOTING GUIDE**LED indicator light in the IR (infrared) sensor is red.**

- A. Battery power is low.
Install four (4) new AA sized alkaline batteries. Check that the orientation of each battery matches the positive (+) and negative (-) symbols shown in the bottom of the battery compartment.
Re-attach battery compartment to control module. Green LED will illuminate. If the Green LED does not illuminate, remove battery compartment for 10 seconds and return into place.

Faucet DOES NOT function.

- A. Batteries not installed or are exhausted.
Install four (4) AA sized alkaline batteries. Check that the orientation of each battery matches the positive (+) and negative (-) symbols shown in the bottom of the battery compartment. Reattach battery compartment to control module. Green LED will illuminate. If the Green LED does not illuminate, remove battery compartment for 10 seconds and return into place.
- B. Power Cable not installed (Hardwire models).
Install power cable and check connection.
- C. Sensor Cable not installed.
Install sensor cable and check connection. Confirm connection guide markings are aligned.
- D. Sensor range is set too short and is not detecting the target.
Increase sensor detection range.

Sensor is activated but faucet DOES NOT deliver water.

- A. Faucet has initiated its adaptive sensing calibration program.
Wait 60 seconds before activating faucet.
- B. Solenoid Cable not connected.
Check solenoid cable connection. Confirm connection guide markings are aligned.

Sensor Range Requires Manual Adjustment.

Sensor Range is measured in units from 1 to 5, with 1 being closest to the faucet and 5 being farthest from the faucet. The factory default Sensor Range is 3.

- A. To determine what the current Sensor Range setting is, press the red "Sensor" button on the upper right hand corner of the Optima Control Box for 1 second. Five seconds after pressing the button, the green LED beside it will blink to indicate the Sensor Range setting. For example, if it is set at 2, the green LED will blink 2 times.
- B. To adjust the Sensor Range, press and hold the red "Sensor" button for three seconds and release once the green LED comes on to indicate that you are in Sensor Range adjustment mode. Then press the "Sensor" button one second at a time for however many times you wish to increase the range. For example, if the Sensor Range is set at 2 and you wish to increase it to 4, press the "Sensor" button two times for one second each time..
- C. If you wish to decrease the Sensor Range, follow the same procedure to enter into Sensor Range adjustment mode, and then press the "Sensor" button one second at a time. The button is designed to go up to 5 units and then back down to 1 unit. For example, if the Sensor Range is set at 4 and you wish to decrease it to 2, press the "Sensor" button three times for one second each time.
- D. To conform your changes, wait 5 seconds and then press the red "Sensor" button on the upper right hand corner of the Optima Control Box for 1 second. Five seconds after pressing the button, the green LED beside it will blink to indicate the Sensor Range setting. For example, if it is now set at 2, the green LED will blink 2 times.

Solenoid produces an audible "CLICK" when an object is placed in the detection zone of the sensor but NO water flows.

- A. Water supply to faucet is not open.
Open supply stop(s).
- B. Inlet fitting filter is clogged.
Remove, clean, and reinsert. Replace with EBF1004 solenoid filter kit if necessary.
- C. Aerator or spray head is clogged.
Remove, clean, and reinsert.

Optima® EBF-550/EBF-550-S/ETF-500**ETF-500-S Faucets Parts & Accessories**

Solenoid valve DOES NOT produce an audible “CLICK” and NO water flows. Green LED illuminates when batteries installed.

- A. Solenoid valve module is not working properly.
Replace EFP103A solenoid valve module.

Faucet delivers only a slow flow or dribble when sensor is activated.

- A. Water supply valve is partially closed.
Open the supply stop(s) completely.
- B. Inlet fitting filter is clogged.
Remove, clean, and reinsert. Replace with EFP101A replacement filter kit if necessary.
- C. Aerator or spray head is clogged.
Remove, clean, and reinsert.

Faucet DOES NOT stop delivering water or continues to drip after user is no longer detected (automatic shut-off fails even when batteries are removed).

- A. Solenoid valve seat is dirty.
Remove, clean, and reinsert solenoid filter. Activate faucet several times to flush out dirt.
- B. Sensor range is set too long and is detecting the sink or some other object.
Reduce sensor detection range.
- C. Solenoid valve module is not working properly.
Replace EFP103A solenoid valve module.

The water temperature is too hot or too cold on a faucet connected to hot and cold supply lines with inlet filter fitting.

- A. Supply stops are not adjusted properly.
Adjust supply stops.

NOTE: For some systems, a thermostatic mixing valve may be required

SLOAN CONNECT APP FAQs

How do I connect my faucet to the Sloan mobile app?

To connect your faucet to the Sloan mobile App, you must complete the following steps:

1. Turn on your smartphone's Bluetooth.
2. Open the Sloan mobile app.
3. Complete all Sign In fields and agree to the End User License Agreement and Terms of Use.
4. Activate your faucets Bluetooth transmitter by slowly waving your hand underneath the faucet three (3) times within ten (10) seconds. Note: water will run during this process.
5. When your faucets Bluetooth transmitter is activated, the Sloan mobile app will display your faucet.
6. Select your faucet to confirm and connect to the Sloan mobile app.

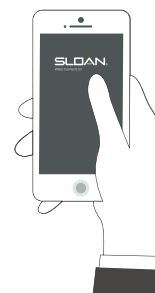

Can I still use my app and faucet if there is no internet connection?

Yes. The Sloan Connect App and faucet are designed to work in offline mode. All connectivity occurs via Bluetooth, which does not require an internet connection. If your phone is running Android 7, there is a built-in feature to prevent abusive BLE scanning. This change prevents an app from stopping and starting BLE scans more than 5 times in a window of 30 seconds. If this app does not detect any faucet and your phone is running Android 7, just exit the app and restart the app 30 seconds later.

My faucet is not showing in advertised devices.

Please be sure your Sloan Optima Control Box has power. To do this, remove the cover with the single screw in the center. Check there are no loose or disconnected wires and ensure the batteries are properly installed. Then repeat the connection process. If you are still experiencing issues, contact Sloan.

How do I save and load settings?

Each time you update settings on a faucet, they are stored in the app. If you would like to load the settings from a previous faucet to a new faucet, connect to that faucet and select the “Load Previous Settings”. This will display a dialogue box showing the previous settings. Click “Confirm” to load those settings into the app, then select “Apply Settings To Faucet” button at the bottom of your dashboard.

Why is the dashboard photo of my faucet not correct?

Each Sloan faucet type has several images associated with it. Use the left and right arrows to view the different faucet images.

How can I use the Sloan Connect App to save information about a specific faucet, like its location?

Select the “Notes” option from the main App screen and use this feature to include up to 120 characters worth of information.

When assistance is required, please contact Sloan Technical Support at:

1-888-SLOAN-14 (1-888-756-2614) (USA only) or +1-847-671-4300 (all other locations),
or visit sloan.com

Optima® EBF-665/ETF-660 Faucets

Parts & Accessories



EBF-665 Deck mount, battery
ETF-660 Deck mount, hardwired

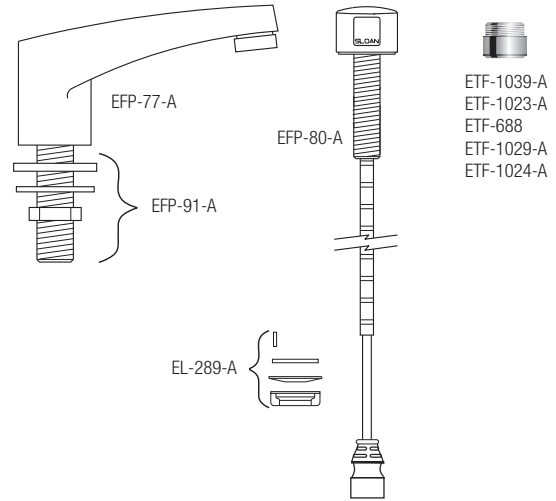

SPOUT ASSEMBLY

Description	Code No.	Part No.
Spout Assembly ETF-660/EBF-665	0367077	EFP-77-A
Spout Mounting Kit	0367091	EFP-91-A
Sensor & Cable Assembly	0367080	EFP-80-A
Sensor Mounting Kit	0305528	EL-289-A

SPRAYHEAD OPTIONS

Description	Type	Code No.	Part No.
0.35 GPM/1.3 Lpm	MLM	3365756	ETF-1039-A
0.5 GPM/1.9 Lpm	MLM	3365092	ETF-1023-A
1.5 GPM/5.7 Lpm	LAM	0365395	ETF-688
2.2 GPM/8.3 Lpm	LAM	3365162	ETF-1029-A
2.2 GPM/8.3 Lpm	AER	3365093	ETF-1024-A

TRIMPLATE OPTIONS

Description	Code No.	Part No.
4"	3365469	ETF-313-A
8"	3365602	ETF-432-A
4" ADM	3365470	ETF-314-A
8" ADM	3365603	ETF-433-A

BELOW DECK ASSEMBLIES

Description	Code No.	Part No.
Control Box No Turbine	0367039	EFP-39-A
Control Box Turbine 0.5 gpm	0367040	EFP-40-A
Control Box Turbine 1.5 gpm	0367011	EFP-11-A
Quick Connect Spout Hose 24"	0367025	EFP-25
Control Box Cover w/Screw	0367010	EFP-10-A
Solenoid Assembly	0367103	EFP-103-A
Battery Pack	3324113	EFX-8-A
Double Inlet Tee Filter Assembly	0367028	EFP-28-A
BDM & Single Inlet Tee Filter Assembly Kit	0367099	EFP-99-A
BDT & Single Inlet Tee Filter Assembly Kit	0367100	EFP-100-A
Replacement Filter Pack-(5) Filter (5) Large O-rings (5) Small O-rings	0367101	EFP-101-A
24 VAC Power Harness Assembly	0367098	EFP-98-A
110V/6VDC Power Supply	0362006	SFP-6
100-240 VAC/6 VDC Power Supply	0362016	SFP-36
120/24 VAC Power Supply	0365534PK	ETF-233
120/24 VAC Power Supply (Canada) Plug-in	0365879	ETF-416
120/24 VAC Power Supply (Box Mount)	0345370PK	EL-248-40
Extension Cable	0362017	SFP-37
Splitter Cable	0362018	SFP-38
Gang Adapter Kit	0362035	SFP-35-A
Faucet to Module Ext. Cable*	0367113	EFP-113-A

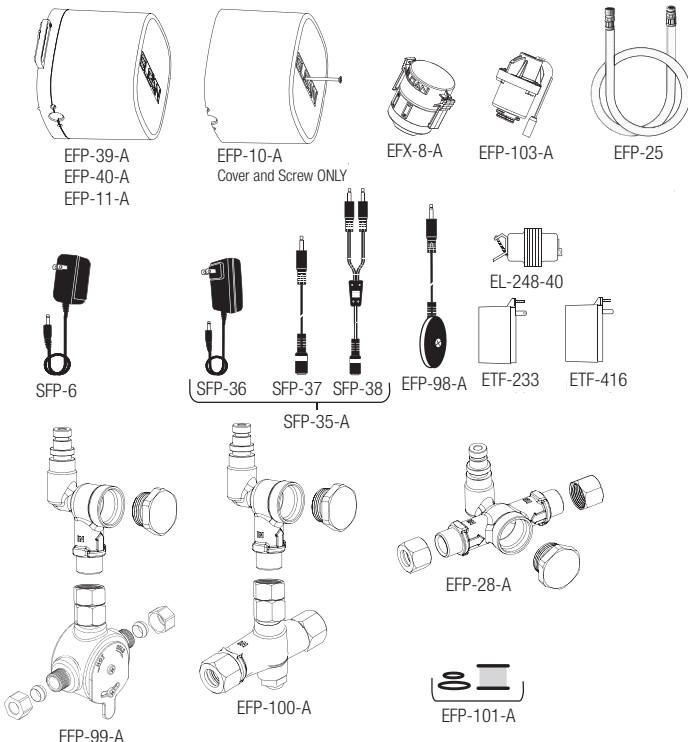

NOTE: Some parts and accessories must be ordered separately
 * Not shown

Optima® EBF-665/ETF-660 Faucets

Parts & Accessories

TROUBLESHOOTING INSTRUCTIONS FOR OPTIMA SENSOR ACTIVATED LAVATORY FAUCETS WITH THE NEW OPTIMA CONTROL BOXES AND THE SLOAN CONNECT SMARTPHONE APP.

NOTE: To automatically check battery strength, troubleshoot, diagnose and report faucet issues with a wireless device, use the Sloan SmartPhone APP. The APP is available free-of-charge at the Apple iPhone APP store for iOS devices or the Google Play APP store for Android devices. For more information about the APP and its capabilities please visit sloan.com.

FAUCET TROUBLESHOOTING GUIDE

LED indicator light in the IR (infrared) sensor is red.

- A. Battery power is low.
Install four (4) new AA sized alkaline batteries. Check that the orientation of each battery matches the positive (+) and negative (-) symbols shown in the bottom of the battery compartment.
Re-attach battery compartment to control module. Green LED will illuminate. If the Green LED does not illuminate, remove battery compartment for 10 seconds and return into place.

Faucet DOES NOT function.

- A. Batteries not installed or are exhausted.
Install four (4) AA sized alkaline batteries. Check that the orientation of each battery matches the positive (+) and negative (-) symbols shown in the bottom of the battery compartment. Reattach battery compartment to control module. Green LED will illuminate. If the Green LED does not illuminate, remove battery compartment for 10 seconds and return into place.
- B. Power Cable not installed (Hardwire models).
Install power cable and check connection.
- C. Sensor Cable not installed.
Install sensor cable and check connection. Confirm connection guide markings are aligned.
- D. Sensor range is set too short and is not detecting the target.
Increase sensor detection range.

Sensor is activated but faucet DOES NOT deliver water.

- A. Faucet has initiated its adaptive sensing calibration program.
Wait 60 seconds before activating faucet.
- B. Solenoid Cable not connected.
Check solenoid cable connection. Confirm connection guide markings are aligned.

Sensor Range Requires Manual Adjustment.

Sensor Range is measured in units from 1 to 5, with 1 being closest to the faucet and 5 being farthest from the faucet. The factory default Sensor Range is 3.

- A. To determine what the current Sensor Range setting is, press the red "Sensor" button on the upper right hand corner of the Optima Control Box for 1 second. Five seconds after pressing the button, the green LED beside it will blink to indicate the Sensor Range setting. For example, if it is set at 2, the green LED will blink 2 times.
- B. To adjust the Sensor Range, press and hold the red "Sensor" button for three seconds and release once the green LED comes on to indicate that you are in Sensor Range adjustment mode. Then press the "Sensor" button one second at a time for however many times you wish to increase the range. For example, if the Sensor Range is set at 2 and you wish to increase it to 4, press the "Sensor" button two times for one second each time..
- C. If you wish to decrease the Sensor Range, follow the same procedure to enter into Sensor Range adjustment mode, and then press the "Sensor" button one second at a time. The button is designed to go up to 5 units and then back down to 1 unit. For example, if the Sensor Range is set at 4 and you wish to decrease it to 2, press the "Sensor" button three times for one second each time.
- D. To conform your changes, wait 5 seconds and then press the red "Sensor" button on the upper right hand corner of the Optima Control Box for 1 second. Five seconds after pressing the button, the green LED beside it will blink to indicate the Sensor Range setting. For example, if it is now set at 2, the green LED will blink 2 times.

Solenoid produces an audible "CLICK" when an object is placed in the detection zone of the sensor but NO water flows.

- A. Water supply to faucet is not open.
Open supply stop(s).
- B. Inlet fitting filter is clogged.
Remove, clean, and reinsert. Replace with EBF1004 solenoid filter kit if necessary.
- C. Aerator or spray head is clogged.
Remove, clean, and reinsert.

Optima® EBF-655/ETF-660 Faucets Parts & Accessories

Solenoid valve DOES NOT produce an audible “CLICK” and NO water flows. Green LED illuminates when batteries installed.

- A. Solenoid valve module is not working properly.
Replace EFP103A solenoid valve module.

Faucet delivers only a slow flow or dribble when sensor is activated.

- A. Water supply valve is partially closed.
Open the supply stop(s) completely.
- B. Inlet fitting filter is clogged.
Remove, clean, and reinsert. Replace with EFP101A replacement filter kit if necessary.
- C. Aerator or spray head is clogged.
Remove, clean, and reinsert.

Faucet DOES NOT stop delivering water or continues to drip after user is no longer detected (automatic shut-off fails even when batteries are removed).

- A. Solenoid valve seat is dirty.
Remove, clean, and reinsert solenoid filter. Activate faucet several times to flush out dirt.
- B. Sensor range is set too long and is detecting the sink or some other object.
Reduce sensor detection range.
- C. Solenoid valve module is not working properly.
Replace EFP103A solenoid valve module.

The water temperature is too hot or too cold on a faucet connected to hot and cold supply lines with inlet filter fitting.

- A. Supply stops are not adjusted properly.
Adjust supply stops.

NOTE: For some systems, a thermostatic mixing valve may be required

SLOAN CONNECT APP FAQs

How do I connect my faucet to the Sloan mobile app?

To connect your faucet to the Sloan mobile App, you must complete the following steps:

1. Turn on your smartphone's Bluetooth.
2. Open the Sloan mobile app.
3. Complete all Sign In fields and agree to the End User License Agreement and Terms of Use.
4. Activate your faucets Bluetooth transmitter by slowly waving your hand underneath the faucet three (3) times within ten (10) seconds. Note: water will run during this process.
5. When your faucets Bluetooth transmitter is activated, the Sloan mobile app will display your faucet.
6. Select your faucet to confirm and connect to the Sloan mobile app.

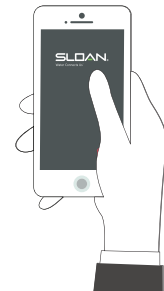

Can I still use my app and faucet if there is no internet connection?

Yes. The Sloan Connect App and faucet are designed to work in offline mode. All connectivity occurs via Bluetooth, which does not require an internet connection. If your phone is running Android 7, there is a built-in feature to prevent abusive BLE scanning. This change prevents an app from stopping and starting BLE scans more than 5 times in a window of 30 seconds. If this app does not detect any faucet and your phone is running Android 7, just exit the app and restart the app 30 seconds later.

My faucet is not showing in advertised devices.

Please be sure your Sloan Optima Control Box has power. To do this, remove the cover with the single screw in the center. Check there are no loose or disconnected wires and ensure the batteries are properly installed. Then repeat the connection process. If you are still experiencing issues, contact Sloan.

How do I save and load settings?

Each time you update settings on a faucet, they are stored in the app. If you would like to load the settings from a previous faucet to a new faucet, connect to that faucet and select the “Load Previous Settings”. This will display a dialogue box showing the previous settings. Click “Confirm” to load those settings into the app, then select “Apply Settings To Faucet” button at the bottom of your dashboard.

Why is the dashboard photo of my faucet not correct?

Each Sloan faucet type has several images associated with it. Use the left and right arrows to view the different faucet images.

How can I use the Sloan Connect App to save information about a specific faucet, like its location?

Select the “Notes” option from the main App screen and use this feature to include up to 120 characters worth of information.

When assistance is required, please contact Sloan Technical Support at:

1-888-SLOAN-14 (1-888-756-2614) (USA only) or +1-847-671-4300 (all other locations), or visit sloan.com

Optima® EBF-775/ETF-770 Faucets

Parts & Accessories



EBF-775 Deck mount, battery
ETF-770 Deck mount, hardwired

SPOUT ASSEMBLY

Description	Code No.	Part No.
Spout Assembly ETF-770/EBF-775	0367078	EFP-78-A
Spout Mounting Kit	0367091	EFP-91-A
Sensor & Cable Assembly	0367080	EFP-80-A
Sensor Mounting Kit	0305528	EL-289-A

SPRAYHEAD OPTIONS

Description	Type	Code No.	Part No.
0.35 GPM/1.3 Lpm	MLM	3365755	ETF-1038-A
0.5 GPM/1.9 Lpm	MLM	3365091	ETF-1021-A
1.0 GPM/3.8 Lpm	MLM	3365557	ETF-1041-A
1.5 GPM/5.7 Lpm	LAM	3365161	ETF-1028-A
2.2 GPM/8.3 Lpm	LAM	3365160	ETF-1027-A

TRIMPLATE OPTIONS

Description	Code No.	Part No.
4"	3365469	ETF-313-A
8"	3365602	ETF-432-A
4" ADM	3365470	ETF-314-A
8" ADM	3365603	ETF-433-A

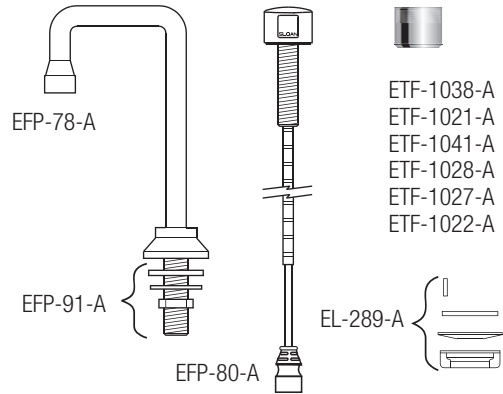

- ETF-1038-A
- ETF-1021-A
- ETF-1041-A
- ETF-1028-A
- ETF-1027-A
- ETF-1022-A

BELOW DECK ASSEMBLIES

Description	Code No.	Part No.
Control Box No Turbine	0367039	EFP-39-A
Control Box Turbine 0.5 gpm	0367040	EFP-40-A
Control Box Turbine 1.5 gpm	0367011	EFP-11-A
Quick Connect Spout Hose 24"	0367025	EFP-25
Control Box Cover w/Screw	0367010	EFP-10-A
Solenoid Assembly	0367103	EFP-103-A
Battery Pack	3324113	EFX-8-A
Double Inlet Tee Filter Assembly	0367028	EFP-28-A
BDM & Single Inlet Tee Filter Assembly Kit	0367099	EFP-99-A
BDT & Single Inlet Tee Filter Assembly Kit	0367100	EFP-100-A
Replacement Filter Pack (5) Filter (5) Large O-rings (5) Small O-rings	0367101	EFP-101-A
24 VAC Power Harness Assembly	0367098	EFP-98-A
110V/6VDC Power Supply	0362006	SFP-6
100-240 VAC/6 VDC Power Supply	0362016	SFP-36
120/24 VAC Power Supply	0365534PK	ETF-233
120/24 VAC Power Supply (Canada) Plug-in	0365879	ETF-416
120/24 VAC Power Supply (Box Mount)	0345370PK	EL-248-40
Extension Cable	0362017	SFP-37
Splitter Cable	0362018	SFP-38
Gang Adapter Kit	0362035	SFP-35-A
Faucet to Module Ext. Cable*	0367113	EFP-113-A

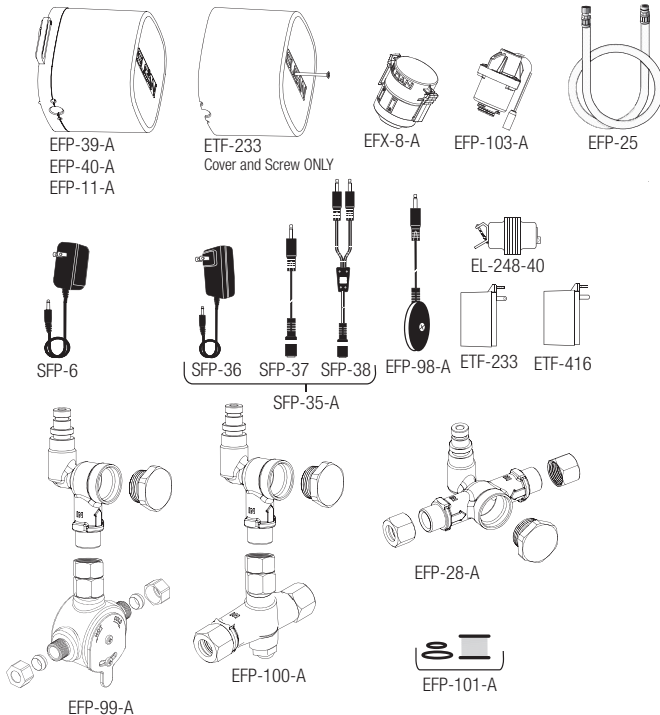

NOTE: Some parts and accessories must be ordered separately
 * Not Shown

Optima® EBF-775/ETF-770 Faucets

Parts & Accessories

TROUBLESHOOTING INSTRUCTIONS FOR OPTIMA SENSOR ACTIVATED LAVATORY FAUCETS WITH THE NEW OPTIMA CONTROL BOXES AND THE SLOAN CONNECT SMARTPHONE APP.

NOTE: To automatically check battery strength, troubleshoot, diagnose and report faucet issues with a wireless device, use the Sloan SmartPhone APP. The APP is available free-of-charge at the Apple iPhone APP store for iOS devices or the Google Play APP store for Android devices. For more information about the APP and its capabilities please visit Sloan.com.

FAUCET TROUBLESHOOTING GUIDE

LED indicator light in the IR (infrared) sensor is red.

- A. Battery power is low.
Install four (4) new AA sized alkaline batteries. Check that the orientation of each battery matches the positive (+) and negative (-) symbols shown in the bottom of the battery compartment.
Re-attach battery compartment to control module. Green LED will illuminate. If the Green LED does not illuminate, remove battery compartment for 10 seconds and return into place.

Faucet DOES NOT function.

- A. Batteries not installed or are exhausted.
Install four (4) AA sized alkaline batteries. Check that the orientation of each battery matches the positive (+) and negative (-) symbols shown in the bottom of the battery compartment. Reattach battery compartment to control module. Green LED will illuminate. If the Green LED does not illuminate, remove battery compartment for 10 seconds and return into place.
- B. Power Cable not installed (Hardwire models).
Install power cable and check connection.
- C. Sensor Cable not installed.
Install sensor cable and check connection. Confirm connection guide markings are aligned.
- D. Sensor range is set too short and is not detecting the target.
Increase sensor detection range.

Sensor is activated but faucet DOES NOT deliver water.

- A. Faucet has initiated its adaptive sensing calibration program.
Wait 60 seconds before activating faucet.
- B. Solenoid Cable not connected.
Check solenoid cable connection. Confirm connection guide markings are aligned.

Sensor Range Requires Manual Adjustment.

Sensor Range is measured in units from 1 to 5, with 1 being closest to the faucet and 5 being farthest from the faucet. The factory default Sensor Range is 3.

- A. To determine what the current Sensor Range setting is, press the red "Sensor" button on the upper right hand corner of the Optima Control Box for 1 second. Five seconds after pressing the button, the green LED beside it will blink to indicate the Sensor Range setting. For example, if it is set at 2, the green LED will blink 2 times.
- B. To adjust the Sensor Range, press and hold the red "Sensor" button for three seconds and release once the green LED comes on to indicate that you are in Sensor Range adjustment mode. Then press the "Sensor" button one second at a time for however many times you wish to increase the range. For example, if the Sensor Range is set at 2 and you wish to increase it to 4, press the "Sensor" button two times for one second each time..
- C. If you wish to decrease the Sensor Range, follow the same procedure to enter into Sensor Range adjustment mode, and then press the "Sensor" button one second at a time. The button is designed to go up to 5 units and then back down to 1 unit. For example, if the Sensor Range is set at 4 and you wish to decrease it to 2, press the "Sensor" button three times for one second each time.
- D. To conform your changes, wait 5 seconds and then press the red "Sensor" button on the upper right hand corner of the Optima Control Box for 1 second. Five seconds after pressing the button, the green LED beside it will blink to indicate the Sensor Range setting. For example, if it is now set at 2, the green LED will blink 2 times.

Solenoid produces an audible "CLICK" when an object is placed in the detection zone of the sensor but NO water flows.

- A. Water supply to faucet is not open.
Open supply stop(s).
- B. Inlet fitting filter is clogged.
Remove, clean, and reinsert. Replace with EBF1004 solenoid filter kit if necessary.
- C. Aerator or spray head is clogged.
Remove, clean, and reinsert.

Optima® EBF-775/ETF-770 Faucets

Parts & Accessories

Solenoid valve DOES NOT produce an audible “CLICK” and NO water flows. Green LED illuminates when batteries installed.

- A. Solenoid valve module is not working properly.
Replace EFP103A solenoid valve module.

Faucet delivers only a slow flow or dribble when sensor is activated.

- A. Water supply valve is partially closed.
Open the supply stop(s) completely.
- B. Inlet fitting filter is clogged.
Remove, clean, and reinsert. Replace with EFP101A replacement filter kit if necessary.
- C. Aerator or spray head is clogged.
Remove, clean, and reinsert.

Faucet DOES NOT stop delivering water or continues to drip after user is no longer detected (automatic shut-off fails even when batteries are removed).

- A. Solenoid valve seat is dirty.
Remove, clean, and reinsert solenoid filter. Activate faucet several times to flush out dirt.
- B. Sensor range is set too long and is detecting the sink or some other object.
Reduce sensor detection range.
- C. Solenoid valve module is not working properly.
Replace EFP103A solenoid valve module.

The water temperature is too hot or too cold on a faucet connected to hot and cold supply lines with inlet filter fitting.

- A. Supply stops are not adjusted properly.
Adjust supply stops.

NOTE: For some systems, a thermostatic mixing valve may be required

SLOAN CONNECT APP FAQs

How do I connect my faucet to the Sloan mobile app?

To connect your faucet to the Sloan mobile App, you must complete the following steps:

1. Turn on your smartphone's Bluetooth.
2. Open the Sloan mobile app.
3. Complete all Sign In fields and agree to the End User License Agreement and Terms of Use.
4. Activate your faucets Bluetooth transmitter by slowly waving your hand underneath the faucet three (3) times within ten (10) seconds. Note: water will run during this process.
5. When your faucets Bluetooth transmitter is activated, the Sloan mobile app will display your faucet.
6. Select your faucet to confirm and connect to the Sloan mobile app.



Can I still use my app and faucet if there is no internet connection?

Yes. The Sloan Connect App and faucet are designed to work in offline mode. All connectivity occurs via Bluetooth, which does not require an internet connection. If your phone is running Android 7, there is a built-in feature to prevent abusive BLE scanning. This change prevents an app from stopping and starting BLE scans more than 5 times in a window of 30 seconds. If this app does not detect any faucet and your phone is running Android 7, just exit the app and restart the app 30 seconds later.

My faucet is not showing in advertised devices.

Please be sure your Sloan Optima Control Box has power. To do this, remove the cover with the single screw in the center. Check there are no loose or disconnected wires and ensure the batteries are properly installed. Then repeat the connection process. If you are still experiencing issues, contact Sloan.

How do I save and load settings?

Each time you update settings on a faucet, they are stored in the app. If you would like to load the settings from a previous faucet to a new faucet, connect to that faucet and select the “Load Previous Settings”. This will display a dialogue box showing the previous settings. Click “Confirm” to load those settings into the app, then select “Apply Settings To Faucet” button at the bottom of your dashboard.

Why is the dashboard photo of my faucet not correct?

Each Sloan faucet type has several images associated with it. Use the left and right arrows to view the different faucet images.

How can I use the Sloan Connect App to save information about a specific faucet, like its location?

Select the “Notes” option from the main App screen and use this feature to include up to 120 characters worth of information.

When assistance is required, please contact Sloan Technical Support at:

1-888-SLOAN-14 (1-888-756-2614) (USA only) or +1-847-671-4300 (all other locations), or visit sloan.com

Optima® EBF-850/ETF-800 Faucets

Parts & Accessories

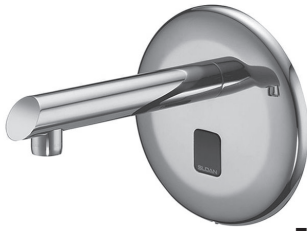

EBF-850 Wall mount, battery
ETF-800 Wall mount, hardwired

SPOUT ASSEMBLY

Description	Code No.	Part No.
Spout Assembly ETF-800/EBF-850	0367082	EFP-82-A
Sensor & Cable Assembly	0367083	EFP-83-A
Spout Mounting Assembly	0365498PK	ETF-798-A

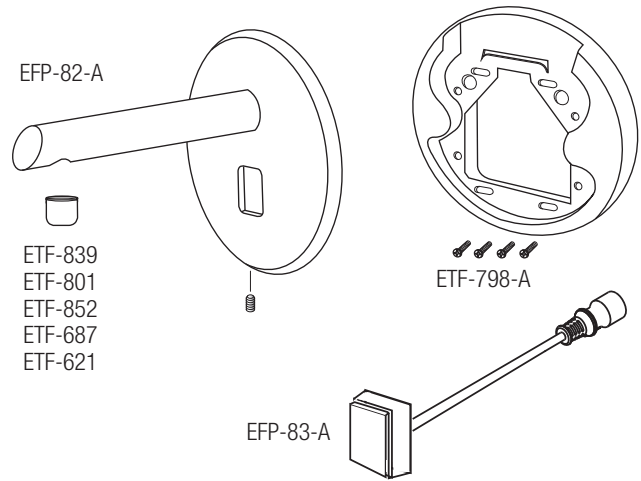

SPRAYHEAD OPTIONS

Description	Type	Code No.	Part No.
0.35 GPM/1.3 Lpm	MLM	0365793	ETF-839
0.5 GPM/1.9 Lpm	MLM	0365420	ETF-801
1.0 GPM/3.8 Lpm	MLM	0365454	ETF-852
1.5 GPM/5.7 Lpm	LAM	0365387	ETF-687
2.2 GPM/8.3 Lpm	LAM	0365147	ETF-621

BELOW DECK ASSEMBLIES

Description	Code No.	Part No.
Control Box No Turbine	0367039	EFP-39-A
Control Box Turbine 0.5 gpm	0367040	EFP-40-A
Control Box Turbine 1.5 gpm	0367011	EFP-11-A
Quick Connect Spout Hose 36"	0367104	EFP-104-A
Control Box Cover w/Screw	0367010	EFP-10-A
Solenoid Assembly	0367103	EFP-103-A
Battery Pack	3324113	EFX-8-A
Double Inlet Tee Filter Assembly	0367028	EFP-28-A
BDM & Single Inlet Tee Filter Assembly Kit	0367099	EFP-99-A
BDT & Single Inlet Tee Filter Assembly Kit	0367100	EFP-100-A
Replacement Filter Pack-(5) Filter (5) Large O-rings (5) Small O-rings	0367101	EFP-101-A
24 VAC Power Harness Assembly	0367098	EFP-98-A
110V/6 VDC Power Supply	0362006	SFP-6
100-240 VAC/6 VDC Power Supply	0362016	SFP-36
120/24 VAC Power Supply	0365534PK	ETF-233
120/24 VAC Power Supply (Canada) Plug-in	0365879	ETF-416
120/24 VAC Power Supply (Box Mount)	0345370PK	EL-248-40
Extension Cable	0362017	SFP-37
Splitter Cable	0362018	SFP-38
Gang Adapter Kit	0362035	SFP-35-A
Faucet to Module Ext. Cable*	0367113	EFP-113-A

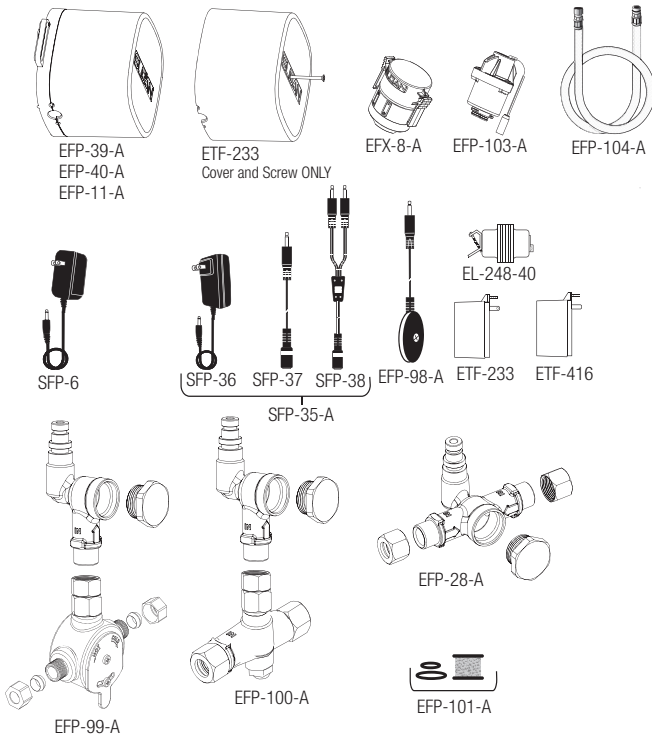

NOTE: Some parts and accessories must be ordered separately.
 *Not Shown

Optima® EBF-850/ETF-800 Faucets

Parts & Accessories

TROUBLESHOOTING INSTRUCTIONS FOR OPTIMA SENSOR ACTIVATED LAVATORY FAUCETS WITH THE NEW OPTIMA CONTROL BOXES AND THE SLOAN CONNECT SMARTPHONE APP.

NOTE: To automatically check battery strength, troubleshoot, diagnose and report faucet issues with a wireless device, use the Sloan SmartPhone APP. The APP is available free-of-charge at the Apple iPhone APP store for iOS devices or the Google Play APP store for Android devices. For more information about the APP and its capabilities please visit sloan.com.

FAUCET TROUBLESHOOTING GUIDE

LED indicator light in the IR (infrared) sensor is red.

- A. Battery power is low.
Install four (4) new AA sized alkaline batteries. Check that the orientation of each battery matches the positive (+) and negative (-) symbols shown in the bottom of the battery compartment.
Re-attach battery compartment to control module. Green LED will illuminate. If the Green LED does not illuminate, remove battery compartment for 10 seconds and return into place.

Faucet DOES NOT function.

- A. Batteries not installed or are exhausted.
Install four (4) AA sized alkaline batteries. Check that the orientation of each battery matches the positive (+) and negative (-) symbols shown in the bottom of the battery compartment. Reattach battery compartment to control module. Green LED will illuminate. If the Green LED does not illuminate, remove battery compartment for 10 seconds and return into place.
- B. Power Cable not installed (Hardwire models).
Install power cable and check connection.
- C. Sensor Cable not installed.
Install sensor cable and check connection. Confirm connection guide markings are aligned.
- D. Sensor range is set too short and is not detecting the target.
Increase sensor detection range.

Sensor is activated but faucet DOES NOT deliver water.

- A. Faucet has initiated its adaptive sensing calibration program.
Wait 60 seconds before activating faucet.
- B. Solenoid Cable not connected.
Check solenoid cable connection. Confirm connection guide markings are aligned.

Sensor Range Requires Manual Adjustment.

Sensor Range is measured in units from 1 to 5, with 1 being closest to the faucet and 5 being farthest from the faucet. The factory default Sensor Range is 3.

- A. To determine what the current Sensor Range setting is, press the red "Sensor" button on the upper right hand corner of the Optima Control Box for 1 second. Five seconds after pressing the button, the green LED beside it will blink to indicate the Sensor Range setting. For example, if it is set at 2, the green LED will blink 2 times.
- B. To adjust the Sensor Range, press and hold the red "Sensor" button for three seconds and release once the green LED comes on to indicate that you are in Sensor Range adjustment mode. Then press the "Sensor" button one second at a time for however many times you wish to increase the range. For example, if the Sensor Range is set at 2 and you wish to increase it to 4, press the "Sensor" button two times for one second each time..
- C. If you wish to decrease the Sensor Range, follow the same procedure to enter into Sensor Range adjustment mode, and then press the "Sensor" button one second at a time. The button is designed to go up to 5 units and then back down to 1 unit. For example, if the Sensor Range is set at 4 and you wish to decrease it to 2, press the "Sensor" button three times for one second each time.
- D. To conform your changes, wait 5 seconds and then press the red "Sensor" button on the upper right hand corner of the Optima Control Box for 1 second. Five seconds after pressing the button, the green LED beside it will blink to indicate the Sensor Range setting. For example, if it is now set at 2, the green LED will blink 2 times.

Solenoid produces an audible "CLICK" when an object is placed in the detection zone of the sensor but NO water flows.

- A. Water supply to faucet is not open.
Open supply stop(s).
- B. Inlet fitting filter is clogged.
Remove, clean, and reinsert. Replace with EBF1004 solenoid filter kit if necessary.
- C. Aerator or spray head is clogged.
Remove, clean, and reinsert.

Optima® EBF-850/ETF-800 Faucets

Parts & Accessories

Solenoid valve DOES NOT produce an audible “CLICK” and NO water flows. Green LED illuminates when batteries installed.

- A. Solenoid valve module is not working properly.
Replace EFP103A solenoid valve module.

Faucet delivers only a slow flow or dribble when sensor is activated.

- A. Water supply valve is partially closed.
Open the supply stop(s) completely.
- B. Inlet fitting filter is clogged.
Remove, clean, and reinsert. Replace with EFP101A replacement filter kit if necessary.
- C. Aerator or spray head is clogged.
Remove, clean, and reinsert.

Faucet DOES NOT stop delivering water or continues to drip after user is no longer detected (automatic shut-off fails even when batteries are removed).

- A. Solenoid valve seat is dirty.
Remove, clean, and reinsert solenoid filter. Activate faucet several times to flush out dirt.
- B. Sensor range is set too long and is detecting the sink or some other object.
Reduce sensor detection range.
- C. Solenoid valve module is not working properly.
Replace EFP103A solenoid valve module.

The water temperature is too hot or too cold on a faucet connected to hot and cold supply lines with inlet filter fitting.

- A. Supply stops are not adjusted properly.
Adjust supply stops.

NOTE: For some systems, a thermostatic mixing valve may be required

SLOAN CONNECT APP FAQs

How do I connect my faucet to the Sloan mobile app?

To connect your faucet to the Sloan mobile App, you must complete the following steps:

1. Turn on your smartphone's Bluetooth.
2. Open the Sloan mobile app.
3. Complete all Sign In fields and agree to the End User License Agreement and Terms of Use.
4. Activate your faucets Bluetooth transmitter by slowly waving your hand underneath the faucet three (3) times within ten (10) seconds. Note: water will run during this process.
5. When your faucets Bluetooth transmitter is activated, the Sloan mobile app will display your faucet.
6. Select your faucet to confirm and connect to the Sloan mobile app.



Can I still use my app and faucet if there is no internet connection?

Yes. The Sloan Connect App and faucet are designed to work in offline mode. All connectivity occurs via Bluetooth, which does not require an internet connection. If your phone is running Android 7, there is a built-in feature to prevent abusive BLE scanning. This change prevents an app from stopping and starting BLE scans more than 5 times in a window of 30 seconds. If this app does not detect any faucet and your phone is running Android 7, just exit the app and restart the app 30 seconds later.

My faucet is not showing in advertised devices.

Please be sure your Sloan Optima Control Box has power. To do this, remove the cover with the single screw in the center. Check there are no loose or disconnected wires and ensure the batteries are properly installed. Then repeat the connection process. If you are still experiencing issues, contact Sloan.

How do I save and load settings?

Each time you update settings on a faucet, they are stored in the app. If you would like to load the settings from a previous faucet to a new faucet, connect to that faucet and select the “Load Previous Settings”. This will display a dialogue box showing the previous settings. Click “Confirm” to load those settings into the app, then select “Apply Settings To Faucet” button at the bottom of your dashboard.

Why is the dashboard photo of my faucet not correct?

Each Sloan faucet type has several images associated with it. Use the left and right arrows to view the different faucet images.

How can I use the Sloan Connect App to save information about a specific faucet, like its location?

Select the “Notes” option from the main App screen and use this feature to include up to 120 characters worth of information.

When assistance is required, please contact Sloan Technical Support at:

1-888-SLOAN-14 (1-888-756-2614) (USA only) or +1-847-671-4300 (all other locations), or visit sloan.com

Optima® EBF-425/ETF-420 Faucets Parts & Accessories



EBF-425 Deck mount, battery
ETF-420 Deck mount, hardwired

SPOUT ASSEMBLY		
Description	Code No.	Part No.
Spout Assembly EBF-425 /ETF-420	0315301	EFP-1016-A
Sensor & Cable Assembly	3315382	EFP-116-A
Sprayhead Carrier Assembly	0315265	EFP-1032-A
Spout Mounting Kit	0315273	EFP-118-A

TRIMPLATE OPTIONS		
Description	Code No.	Part No.
4"	3365468	ETF-312-A
8"	3365024	ETF-510-A

SPRAYHEAD OPTIONS			
Description	Type	Code No.	Part No.
0.35 GPM/1.3 Lpm	MLM	3362005	EFP-119
0.5 GPM/1.9 Lpm	MLM	33620001	EFP-120

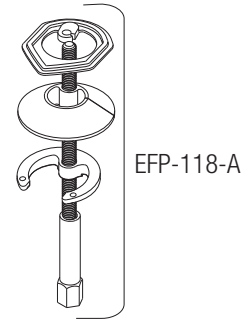
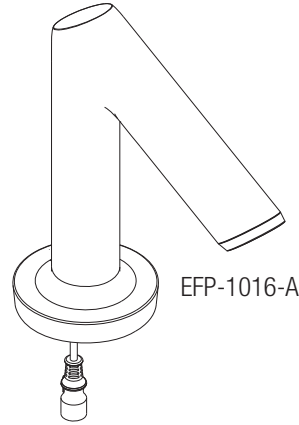

BELOW DECK ASSEMBLIES		
Description	Code No	Part No.
Control Box No Turbine	0367039	EFP-39-A
Control Box Turbine 0.5 gpm	0367040	EFP-40-A
Control Box Turbine 1.5 gpm	0367011	EFP-11-A
Quick Connect Spout Hose 24"	0315251	EFP-1022
Control Box Cover w/Screw	0367010	EFP-10-A
Solenoid Assembly	0367103	EFP-103-A
Battery Pack	3324113	EFX-8-A
Double Inlet Tee Filter Assembly	0367028	EFP-28-A
BDM & Single Inlet Tee Filter Assembly Kit	0367099	EFP-99-A
BDT & Single Inlet Tee Filter Assembly Kit	0367100	EFP-100-A
Replacement Filter Pack-(5) Filter (5) Large O-rings (5) Small O-rings	0367101	EFP-101-A
24 VAC Power Harness Assembly	0367098	EFP-98-A
110V/6 VDC Power Supply	0362006	SFP-6
100-240 VAC/6 VDC Power Supply	0362016	SFP-36
120/24 VAC Power Supply	0365534PK	ETF-233
120/24 VAC Power Supply (Canada) Plug-in	0365879	ETF-416
120/24 VAC Power Supply (Box Mount)	0345370PK	EL-248-40
Extension Cable	0362017	SFP-37
Splitter Cable	0362018	SFP-38
Gang Adapter Kit	0362035	SFP-35-A
Faucet to Module Ext. Cable*	0367113	EFP-113-A

NOTE: Some parts and accessories must be ordered separately * not shown

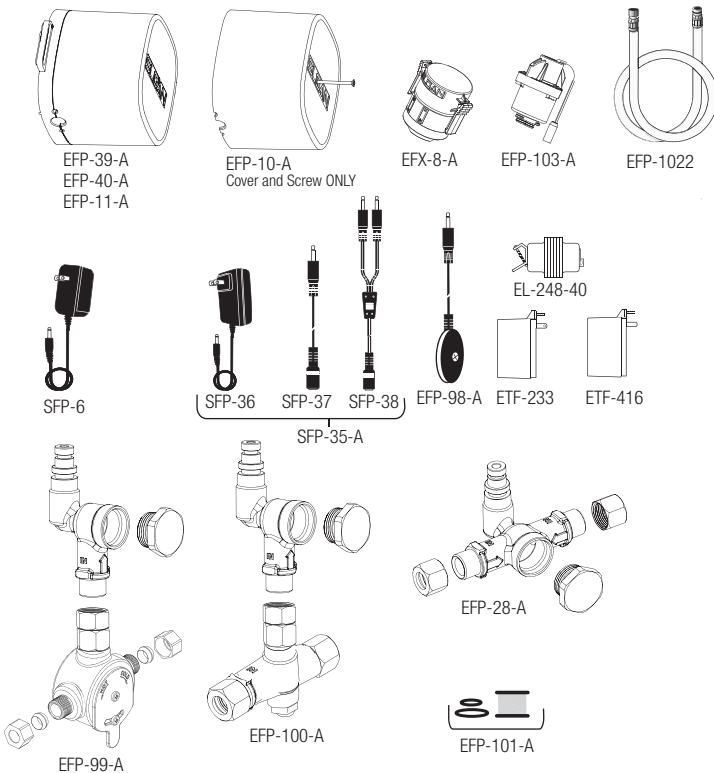

Optima® EBF-425/ETF-420 Faucets

Parts & Accessories

TROUBLESHOOTING INSTRUCTIONS FOR OPTIMA SENSOR ACTIVATED LAVATORY FAUCETS WITH THE NEW OPTIMA CONTROL BOXES AND THE SLOAN CONNECT SMARTPHONE APP.

NOTE: To automatically check battery strength, troubleshoot, diagnose and report faucet issues with a wireless device, use the Sloan SmartPhone APP. The APP is available free-of-charge at the Apple iPhone APP store for iOS devices or the Google Play APP store for Android devices. For more information about the APP and its capabilities please visit Sloan.com.

FAUCET TROUBLESHOOTING GUIDE

LED indicator light in the IR (infrared) sensor is red.

- A. Battery power is low.
Install four (4) new AA sized alkaline batteries. Check that the orientation of each battery matches the positive (+) and negative (-) symbols shown in the bottom of the battery compartment.
Re-attach battery compartment to control module. Green LED will illuminate. If the Green LED does not illuminate, remove battery compartment for 10 seconds and return into place.

Faucet DOES NOT function.

- A. Batteries not installed or are exhausted.
Install four (4) AA sized alkaline batteries. Check that the orientation of each battery matches the positive (+) and negative (-) symbols shown in the bottom of the battery compartment. Reattach battery compartment to control module. Green LED will illuminate. If the Green LED does not illuminate, remove battery compartment for 10 seconds and return into place.
- B. Power Cable not installed (Hardwire models).
Install power cable and check connection.
- C. Sensor Cable not installed.
Install sensor cable and check connection. Confirm connection guide markings are aligned.
- D. Sensor range is set too short and is not detecting the target.
Increase sensor detection range.

Sensor is activated but faucet DOES NOT deliver water.

- A. Faucet has initiated its adaptive sensing calibration program.
Wait 60 seconds before activating faucet.
- B. Solenoid Cable not connected.
Check solenoid cable connection. Confirm connection guide markings are aligned.

Sensor Range Requires Manual Adjustment.

Sensor Range is measured in units from 1 to 5, with 1 being closest to the faucet and 5 being farthest from the faucet. The factory default Sensor Range is 3.

- A. To determine what the current Sensor Range setting is, press the red "Sensor" button on the upper right hand corner of the Optima Control Box for 1 second. Five seconds after pressing the button, the green LED beside it will blink to indicate the Sensor Range setting. For example, if it is set at 2, the green LED will blink 2 times.
- B. To adjust the Sensor Range, press and hold the red "Sensor" button for three seconds and release once the green LED comes on to indicate that you are in Sensor Range adjustment mode. Then press the "Sensor" button one second at a time for however many times you wish to increase the range. For example, if the Sensor Range is set at 2 and you wish to increase it to 4, press the "Sensor" button two times for one second each time..
- C. If you wish to decrease the Sensor Range, follow the same procedure to enter into Sensor Range adjustment mode, and then press the "Sensor" button one second at a time. The button is designed to go up to 5 units and then back down to 1 unit. For example, if the Sensor Range is set at 4 and you wish to decrease it to 2, press the "Sensor" button three times for one second each time.
- D. To conform your changes, wait 5 seconds and then press the red "Sensor" button on the upper right hand corner of the Optima Control Box for 1 second. Five seconds after pressing the button, the green LED beside it will blink to indicate the Sensor Range setting. For example, if it is now set at 2, the green LED will blink 2 times.

Solenoid produces an audible "CLICK" when an object is placed in the detection zone of the sensor but NO water flows.

- A. Water supply to faucet is not open.
Open supply stop(s).
- B. Inlet fitting filter is clogged.
Remove, clean, and reinsert. Replace with EBF1004 solenoid filter kit if necessary.
- C. Aerator or spray head is clogged.
Remove, clean, and reinsert.

Optima® EBF-425/ETF-420 Faucets

Parts & Accessories

Solenoid valve DOES NOT produce an audible “CLICK” and NO water flows. Green LED illuminates when batteries installed.

- A. Solenoid valve module is not working properly.
Replace EFP103A solenoid valve module.

Faucet delivers only a slow flow or dribble when sensor is activated.

- A. Water supply valve is partially closed.
Open the supply stop(s) completely.
- B. Inlet fitting filter is clogged.
Remove, clean, and reinsert. Replace with EFP101A replacement filter kit if necessary.
- C. Aerator or spray head is clogged.
Remove, clean, and reinsert.

Faucet DOES NOT stop delivering water or continues to drip after user is no longer detected (automatic shut-off fails even when batteries are removed).

- A. Solenoid valve seat is dirty.
Remove, clean, and reinsert solenoid filter. Activate faucet several times to flush out dirt.
- B. Sensor range is set too long and is detecting the sink or some other object.
Reduce sensor detection range.
- C. Solenoid valve module is not working properly.
Replace EFP103A solenoid valve module.

The water temperature is too hot or too cold on a faucet connected to hot and cold supply lines with inlet filter fitting.

- A. Supply stops are not adjusted properly.
Adjust supply stops.

NOTE: For some systems, a thermostatic mixing valve may be required

SLOAN CONNECT APP FAQs

How do I connect my faucet to the Sloan mobile app?

To connect your faucet to the Sloan mobile App, you must complete the following steps:

1. Turn on your smartphone's Bluetooth.
2. Open the Sloan mobile app.
3. Complete all Sign In fields and agree to the End User License Agreement and Terms of Use.
4. Activate your faucets Bluetooth transmitter by slowly waving your hand underneath the faucet three (3) times within ten (10) seconds. Note: water will run during this process.
5. When your faucets Bluetooth transmitter is activated, the Sloan mobile app will display your faucet.
6. Select your faucet to confirm and connect to the Sloan mobile app.

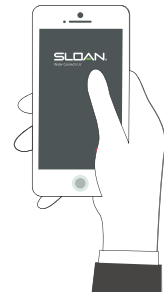

Can I still use my app and faucet if there is no internet connection?

Yes. The Sloan Connect App and faucet are designed to work in offline mode. All connectivity occurs via Bluetooth, which does not require an internet connection. If your phone is running Android 7, there is a built-in feature to prevent abusive BLE scanning. This change prevents an app from stopping and starting BLE scans more than 5 times in a window of 30 seconds. If this app does not detect any faucet and your phone is running Android 7, just exit the app and restart the app 30 seconds later.

My faucet is not showing in advertised devices.

Please be sure your Sloan Optima Control Box has power. To do this, remove the cover with the single screw in the center. Check there are no loose or disconnected wires and ensure the batteries are properly installed. Then repeat the connection process. If you are still experiencing issues, contact Sloan.

How do I save and load settings?

Each time you update settings on a faucet, they are stored in the app. If you would like to load the settings from a previous faucet to a new faucet, connect to that faucet and select the “Load Previous Settings”. This will display a dialogue box showing the previous settings. Click “Confirm” to load those settings into the app, then select “Apply Settings To Faucet” button at the bottom of your dashboard.

Why is the dashboard photo of my faucet not correct?

Each Sloan faucet type has several images associated with it. Use the left and right arrows to view the different faucet images.

How can I use the Sloan Connect App to save information about a specific faucet, like its location?

Select the “Notes” option from the main App screen and use this feature to include up to 120 characters worth of information.

When assistance is required, please contact Sloan Technical Support at:

1-888-SLOAN-14 (1-888-756-2614) (USA only) or +1-847-671-4300 (all other locations), or visit sloan.com

Optima® EBF-415/ETF-410 Faucets

Parts & Accessories



EBF-415 Deck mount, battery
ETF-410 Deck mount, hardwired

SPOUT ASSEMBLY		
Description	Code No.	Part No.
Spout Assembly EBF-415/ETF-410	0315250	EFP-1019-A
Sensor & Cable Assembly	3315431	EFP-114-A
Spout Mounting Kit	0315311	EFP-117-A

TRIMPLATE OPTIONS		
Description	Code No.	Part No.
4"	3365468	ETF-312-A
8"	3365024	ETF-510-A

SPRAYHEAD OPTIONS			
Description	Type	Code No.	Part No.
0.35 GPM/1.3 Lpm	MLM	3362005	EFP-119
0.5 GPM/1.9 Lpm	MLM	3362001	EFP-120

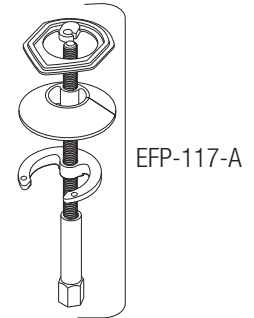
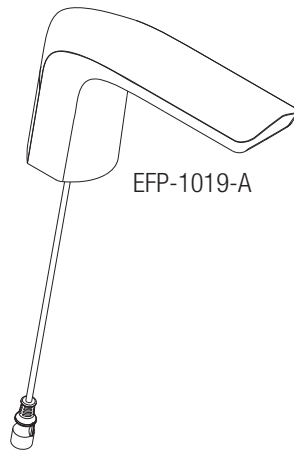

BELOW DECK ASSEMBLIES		
Description	Code No.	Part No.
Control Box No Turbine	0367039	EFP-39-A
Control Box Turbine 0.5 gpm	0367040	EFP-40-A
Control Box Turbine 1.5 gpm	0367011	EFP-11-A
Quick Connect Spout Hose 24"	0367025	EFP-25
Control Box Cover w/Screw	0367010	EFP-10-A
Solenoid Assembly	0367103	EFP-103-A
Battery Pack	3324113	EFX-8-A
Double Inlet Tee Filter Assembly	0367028	EFP-28-A
BDM & Single Inlet Tee Filter Assembly Kit	0367099	EFP-99-A
BDT & Single Inlet Tee Filter Assembly Kit	0367100	EFP-100-A
Replacement Filter Pack-(5) Filter (5) Large O-rings (5) Small O-rings	0367101	EFP-101-A
24 VAC Power Harness Assembly	0367098	EFP-98-A
110V/6 VDC Power Supply	0362006	SFP-6
100-240 VAC/6 VDC Power Supply	0362016	SFP-36
120/24 VAC Power Supply	0365534PK	ETF-233
120/24 VAC Power Supply (Canada) Plug-in	0365879	ETF-416
120/24 VAC Power Supply (Box Mount)	0345370PK	EL-248-40
Extension Cable	0362017	SFP-37
Splitter Cable	0362018	SFP-38
Gang Adapter Kit	0362035	SFP-35-A
Faucet to Module Ext. Cable*	0367113	EFP-113-A

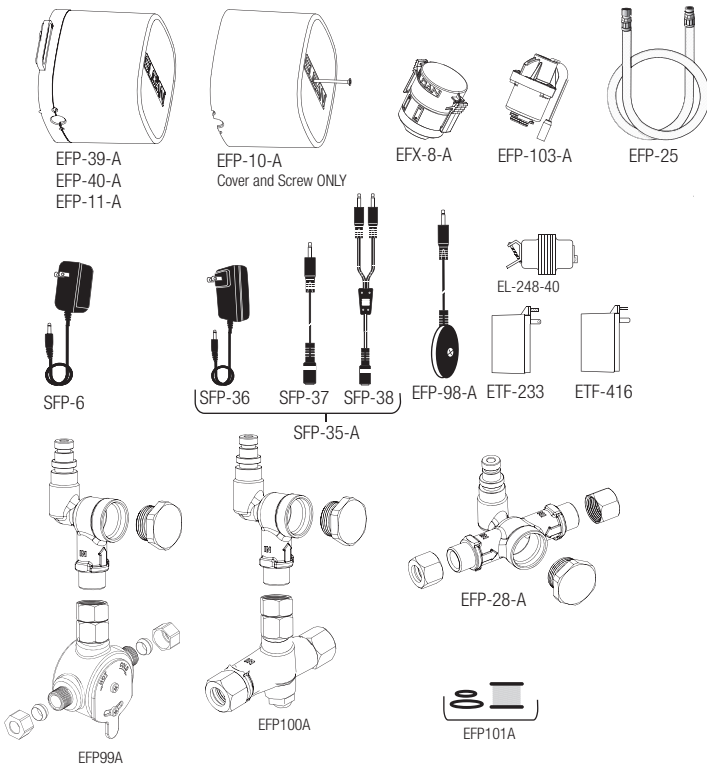

NOTE: Some parts and accessories must be ordered separately
 * not shown

Optima® EBF-415/ETF-410 Faucets

Parts & Accessories

TROUBLESHOOTING INSTRUCTIONS FOR OPTIMA SENSOR ACTIVATED LAVATORY FAUCETS WITH THE NEW OPTIMA CONTROL BOXES AND THE SLOAN CONNECT SMARTPHONE APP.

NOTE: To automatically check battery strength, troubleshoot, diagnose and report faucet issues with a wireless device, use the Sloan SmartPhone APP. The APP is available free-of-charge at the Apple iPhone APP store for iOS devices or the Google Play APP store for Android devices. For more information about the APP and its capabilities please visit Sloan.com.

FAUCET TROUBLESHOOTING GUIDE

LED indicator light in the IR (infrared) sensor is red.

- A. Battery power is low.
Install four (4) new AA sized alkaline batteries. Check that the orientation of each battery matches the positive (+) and negative (-) symbols shown in the bottom of the battery compartment.
Re-attach battery compartment to control module. Green LED will illuminate. If the Green LED does not illuminate, remove battery compartment for 10 seconds and return into place.

Faucet DOES NOT function.

- A. Batteries not installed or are exhausted.
Install four (4) AA sized alkaline batteries. Check that the orientation of each battery matches the positive (+) and negative (-) symbols shown in the bottom of the battery compartment. Reattach battery compartment to control module. Green LED will illuminate. If the Green LED does not illuminate, remove battery compartment for 10 seconds and return into place.
- B. Power Cable not installed (Hardwire models).
Install power cable and check connection.
- C. Sensor Cable not installed.
Install sensor cable and check connection. Confirm connection guide markings are aligned.
- D. Sensor range is set too short and is not detecting the target.
Increase sensor detection range.

Sensor is activated but faucet DOES NOT deliver water.

- A. Faucet has initiated its adaptive sensing calibration program.
Wait 60 seconds before activating faucet.
- B. Solenoid Cable not connected.
Check solenoid cable connection. Confirm connection guide markings are aligned.

Sensor Range Requires Manual Adjustment.

Sensor Range is measured in units from 1 to 5, with 1 being closest to the faucet and 5 being farthest from the faucet. The factory default Sensor Range is 3.

- A. To determine what the current Sensor Range setting is, press the red "Sensor" button on the upper right hand corner of the Optima Control Box for 1 second. Five seconds after pressing the button, the green LED beside it will blink to indicate the Sensor Range setting. For example, if it is set at 2, the green LED will blink 2 times.
- B. To adjust the Sensor Range, press and hold the red "Sensor" button for three seconds and release once the green LED comes on to indicate that you are in Sensor Range adjustment mode. Then press the "Sensor" button one second at a time for however many times you wish to increase the range. For example, if the Sensor Range is set at 2 and you wish to increase it to 4, press the "Sensor" button two times for one second each time..
- C. If you wish to decrease the Sensor Range, follow the same procedure to enter into Sensor Range adjustment mode, and then press the "Sensor" button one second at a time. The button is designed to go up to 5 units and then back down to 1 unit. For example, if the Sensor Range is set at 4 and you wish to decrease it to 2, press the "Sensor" button three times for one second each time.
- D. To conform your changes, wait 5 seconds and then press the red "Sensor" button on the upper right hand corner of the Optima Control Box for 1 second. Five seconds after pressing the button, the green LED beside it will blink to indicate the Sensor Range setting. For example, if it is now set at 2, the green LED will blink 2 times.

Solenoid produces an audible "CLICK" when an object is placed in the detection zone of the sensor but NO water flows.

- A. Water supply to faucet is not open.
Open supply stop(s).
- B. Inlet fitting filter is clogged.
Remove, clean, and reinsert. Replace with EBF1004 solenoid filter kit if necessary.
- C. Aerator or spray head is clogged.
Remove, clean, and reinsert.

Optima® EBF-415/ETF-410 Faucets Parts & Accessories

Solenoid valve DOES NOT produce an audible “CLICK” and NO water flows. Green LED illuminates when batteries installed.

- A. Solenoid valve module is not working properly.
Replace EFP103A solenoid valve module.

Faucet delivers only a slow flow or dribble when sensor is activated.

- A. Water supply valve is partially closed.
Open the supply stop(s) completely.
- B. Inlet fitting filter is clogged.
Remove, clean, and reinsert. Replace with EFP101A replacement filter kit if necessary.
- C. Aerator or spray head is clogged.
Remove, clean, and reinsert.

Faucet DOES NOT stop delivering water or continues to drip after user is no longer detected (automatic shut-off fails even when batteries are removed).

- A. Solenoid valve seat is dirty.
Remove, clean, and reinsert solenoid filter. Activate faucet several times to flush out dirt.
- B. Sensor range is set too long and is detecting the sink or some other object.
Reduce sensor detection range.
- C. Solenoid valve module is not working properly.
Replace EFP103A solenoid valve module.

The water temperature is too hot or too cold on a faucet connected to hot and cold supply lines with inlet filter fitting.

- A. Supply stops are not adjusted properly.
Adjust supply stops.

NOTE: For some systems, a thermostatic mixing valve may be required

SLOAN CONNECT APP FAQs

How do I connect my faucet to the Sloan mobile app?

To connect your faucet to the Sloan mobile App, you must complete the following steps:

1. Turn on your smartphone's Bluetooth.
2. Open the Sloan mobile app.
3. Complete all Sign In fields and agree to the End User License Agreement and Terms of Use.
4. Activate your faucets Bluetooth transmitter by slowly waving your hand underneath the faucet three (3) times within ten (10) seconds. Note: water will run during this process.
5. When your faucets Bluetooth transmitter is activated, the Sloan mobile app will display your faucet.
6. Select your faucet to confirm and connect to the Sloan mobile app.



Can I still use my app and faucet if there is no internet connection?

Yes. The Sloan Connect App and faucet are designed to work in offline mode. All connectivity occurs via Bluetooth, which does not require an internet connection. If your phone is running Android 7, there is a built-in feature to prevent abusive BLE scanning. This change prevents an app from stopping and starting BLE scans more than 5 times in a window of 30 seconds. If this app does not detect any faucet and your phone is running Android 7, just exit the app and restart the app 30 seconds later.

My faucet is not showing in advertised devices.

Please be sure your Sloan Optima Control Box has power. To do this, remove the cover with the single screw in the center. Check there are no loose or disconnected wires and ensure the batteries are properly installed. Then repeat the connection process. If you are still experiencing issues, contact Sloan.

How do I save and load settings?

Each time you update settings on a faucet, they are stored in the app. If you would like to load the settings from a previous faucet to a new faucet, connect to that faucet and select the “Load Previous Settings”. This will display a dialogue box showing the previous settings. Click “Confirm” to load those settings into the app, then select “Apply Settings To Faucet” button at the bottom of your dashboard.

Why is the dashboard photo of my faucet not correct?

Each Sloan faucet type has several images associated with it. Use the left and right arrows to view the different faucet images.

How can I use the Sloan Connect App to save information about a specific faucet, like its location?

Select the “Notes” option from the main App screen and use this feature to include up to 120 characters worth of information.

When assistance is required, please contact Sloan Technical Support at:

1-888-SLOAN-14 (1-888-756-2614) (USA only) or +1-847-671-4300 (all other locations), or visit sloan.com

Optima® EBF-815/ETF-810 Faucets

Parts & Accessories



EBF-815 Wall mount, battery
ETF-810 Wall mount, hardwired

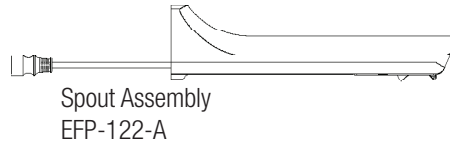

Spout Assembly
EFP-122-A



EFP-114-A

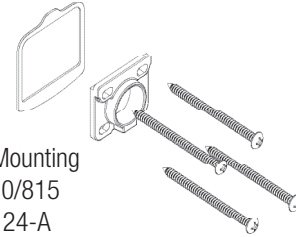

Wall Mounting
Kit 810/815
EFP-124-A

SPOUT ASSEMBLY

Description	Code No.	Part No.
Spout Assembly EBF-815 /ETF-810	03150019	EFP-122A
Wall Mounting Kit 815/810	33620004	EFP-124A
Sensor and Cable Assembly	3315431	EFP-114A

SPRAYHEAD OPTIONS

Description	Type	Code No.	Part No.
0.35 GPM/1.3 Lpm	MLM	3362005	EFP-119
0.5 GPM/1.9 Lpm	MLM	3362001	EFP-120

Description	Code No.	Part No.
Control Box No Turbine	0367039	EFP-39-A
Control Box Turbine 0.5 gpm	0367040	EFP-40-A
Control Box Turbine 1.5 gpm	0367011	EFP-11-A
Quick Connect Spout Hose 36"	0315322	EFP-1018
Control Box Cover w/Screw	0367010	EFP-10-A
Solenoid Assembly	0367103	EFP-103-A
Battery Pack	3324113	EFX-8-A
Double Inlet Tee Filter Assembly	0367028	EFP-28-A
BDM & Single Inlet Tee Filter Assembly Kit	0367099	EFP-99-A
BDT & Single Inlet Tee Filter Assembly Kit	0367100	EFP-100-A
Replacement Filter Pack-(5) Filter (5) Large O-rings (5) Small O-rings	0367101	EFP-101-A
24 VAC Power Harness Assembly	0367098	EFP-98-A
110V/6 VDC Power Supply	0362006	SFP-6
100-240 VAC/6 VDC Power Supply	0362016	SFP-36
120/24 VAC Power Supply	0365534PK	ETF-233
120/24 VAC Power Supply (Canada) Plug-in	0365879	ETF-416
120/24 VAC Power Supply (Box Mount)	0345370PK	EL-248-40
Extension Cable	0362017	SFP-37
Splitter Cable	0362018	SFP-38
Gang Adapter Kit	0362035	SFP-35-A
Faucet to Module Ext. Cable*	0367113	EFP-113-A

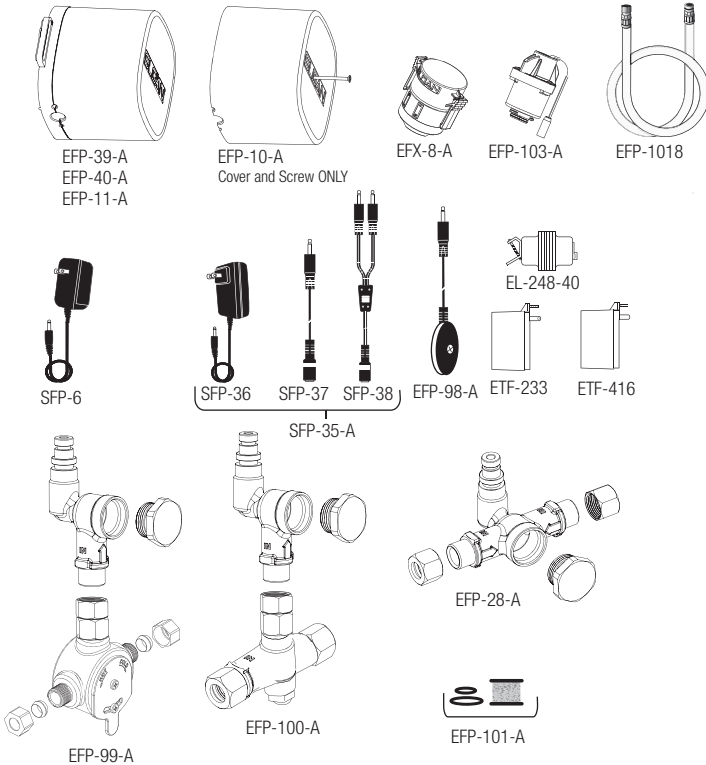

NOTE: Some parts and accessories must be ordered separately
 * not shown

Optima® EBF-815/ETF-810 Faucets

Parts & Accessories

TROUBLESHOOTING INSTRUCTIONS FOR OPTIMA SENSOR ACTIVATED LAVATORY FAUCETS WITH THE NEW OPTIMA CONTROL BOXES AND THE SLOAN CONNECT SMARTPHONE APP.

NOTE: To automatically check battery strength, troubleshoot, diagnose and report faucet issues with a wireless device, use the Sloan SmartPhone APP. The APP is available free-of-charge at the Apple iPhone APP store for iOS devices or the Google Play APP store for Android devices. For more information about the APP and its capabilities please visit Sloan.com.

FAUCET TROUBLESHOOTING GUIDE

LED indicator light in the IR (infrared) sensor is red.

- A. Battery power is low.
Install four (4) new AA sized alkaline batteries. Check that the orientation of each battery matches the positive (+) and negative (-) symbols shown in the bottom of the battery compartment.
Re-attach battery compartment to control module. Green LED will illuminate. If the Green LED does not illuminate, remove battery compartment for 10 seconds and return into place.

Faucet DOES NOT function.

- A. Batteries not installed or are exhausted.
Install four (4) AA sized alkaline batteries. Check that the orientation of each battery matches the positive (+) and negative (-) symbols shown in the bottom of the battery compartment. Reattach battery compartment to control module. Green LED will illuminate. If the Green LED does not illuminate, remove battery compartment for 10 seconds and return into place.
- B. Power Cable not installed (Hardwire models).
Install power cable and check connection.
- C. Sensor Cable not installed.
Install sensor cable and check connection. Confirm connection guide markings are aligned.
- D. Sensor range is set too short and is not detecting the target.
Increase sensor detection range.

Sensor is activated but faucet DOES NOT deliver water.

- A. Faucet has initiated its adaptive sensing calibration program.
Wait 60 seconds before activating faucet.
- B. Solenoid Cable not connected.
Check solenoid cable connection. Confirm connection guide markings are aligned.

Sensor Range Requires Manual Adjustment.

Sensor Range is measured in units from 1 to 5, with 1 being closest to the faucet and 5 being farthest from the faucet. The factory default Sensor Range is 3.

- A. To determine what the current Sensor Range setting is, press the red "Sensor" button on the upper right hand corner of the Optima Control Box for 1 second. Five seconds after pressing the button, the green LED beside it will blink to indicate the Sensor Range setting. For example, if it is set at 2, the green LED will blink 2 times.
- B. To adjust the Sensor Range, press and hold the red "Sensor" button for three seconds and release once the green LED comes on to indicate that you are in Sensor Range adjustment mode. Then press the "Sensor" button one second at a time for however many times you wish to increase the range. For example, if the Sensor Range is set at 2 and you wish to increase it to 4, press the "Sensor" button two times for one second each time..
- C. If you wish to decrease the Sensor Range, follow the same procedure to enter into Sensor Range adjustment mode, and then press the "Sensor" button one second at a time. The button is designed to go up to 5 units and then back down to 1 unit. For example, if the Sensor Range is set at 4 and you wish to decrease it to 2, press the "Sensor" button three times for one second each time.
- D. To conform your changes, wait 5 seconds and then press the red "Sensor" button on the upper right hand corner of the Optima Control Box for 1 second. Five seconds after pressing the button, the green LED beside it will blink to indicate the Sensor Range setting. For example, if it is now set at 2, the green LED will blink 2 times.

Solenoid produces an audible "CLICK" when an object is placed in the detection zone of the sensor but NO water flows.

- A. Water supply to faucet is not open.
Open supply stop(s).
- B. Inlet fitting filter is clogged.
Remove, clean, and reinsert. Replace with EBF1004 solenoid filter kit if necessary.
- C. Aerator or spray head is clogged.
Remove, clean, and reinsert.

Optima® EBF-815/ETF-810 Faucets

Parts & Accessories

Solenoid valve DOES NOT produce an audible “CLICK” and NO water flows. Green LED illuminates when batteries installed.

- A. Solenoid valve module is not working properly.
Replace EFP103A solenoid valve module.

Faucet delivers only a slow flow or dribble when sensor is activated.

- A. Water supply valve is partially closed.
Open the supply stop(s) completely.
- B. Inlet fitting filter is clogged.
Remove, clean, and reinsert. Replace with EFP101A replacement filter kit if necessary.
- C. Aerator or spray head is clogged.
Remove, clean, and reinsert.

Faucet DOES NOT stop delivering water or continues to drip after user is no longer detected (automatic shut-off fails even when batteries are removed).

- A. Solenoid valve seat is dirty.
Remove, clean, and reinsert solenoid filter. Activate faucet several times to flush out dirt.
- B. Sensor range is set too long and is detecting the sink or some other object.
Reduce sensor detection range.
- C. Solenoid valve module is not working properly.
Replace EFP103A solenoid valve module.

The water temperature is too hot or too cold on a faucet connected to hot and cold supply lines with inlet filter fitting.

- A. Supply stops are not adjusted properly.
Adjust supply stops.

NOTE: For some systems, a thermostatic mixing valve may be required

SLOAN CONNECT APP FAQs

How do I connect my faucet to the Sloan mobile app?

To connect your faucet to the Sloan mobile App, you must complete the following steps:

1. Turn on your smartphone's Bluetooth.
2. Open the Sloan mobile app.
3. Complete all Sign In fields and agree to the End User License Agreement and Terms of Use.
4. Activate your faucets Bluetooth transmitter by slowly waving your hand underneath the faucet three (3) times within ten (10) seconds. Note: water will run during this process.
5. When your faucets Bluetooth transmitter is activated, the Sloan mobile app will display your faucet.
6. Select your faucet to confirm and connect to the Sloan mobile app.

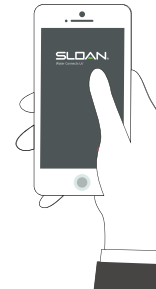

Can I still use my app and faucet if there is no internet connection?

Yes. The Sloan Connect App and faucet are designed to work in offline mode. All connectivity occurs via Bluetooth, which does not require an internet connection. If your phone is running Android 7, there is a built-in feature to prevent abusive BLE scanning. This change prevents an app from stopping and starting BLE scans more than 5 times in a window of 30 seconds. If this app does not detect any faucet and your phone is running Android 7, just exit the app and restart the app 30 seconds later.

My faucet is not showing in advertised devices.

Please be sure your Sloan Optima Control Box has power. To do this, remove the cover with the single screw in the center. Check there are no loose or disconnected wires and ensure the batteries are properly installed. Then repeat the connection process. If you are still experiencing issues, contact Sloan.

How do I save and load settings?

Each time you update settings on a faucet, they are stored in the app. If you would like to load the settings from a previous faucet to a new faucet, connect to that faucet and select the “Load Previous Settings”. This will display a dialogue box showing the previous settings. Click “Confirm” to load those settings into the app, then select “Apply Settings To Faucet” button at the bottom of your dashboard.

Why is the dashboard photo of my faucet not correct?

Each Sloan faucet type has several images associated with it. Use the left and right arrows to view the different faucet images.

How can I use the Sloan Connect App to save information about a specific faucet, like its location?

Select the “Notes” option from the main App screen and use this feature to include up to 120 characters worth of information.

When assistance is required, please contact Sloan Technical Support at:

1-888-SLOAN-14 (1-888-756-2614) (USA only) or +1-847-671-4300 (all other locations), or visit sloan.com

Optima® EBF-825/ETF-820 Faucets

Parts & Accessories



EBF-825 Wall mount, battery
ETF-820 Wall mount, hardwired

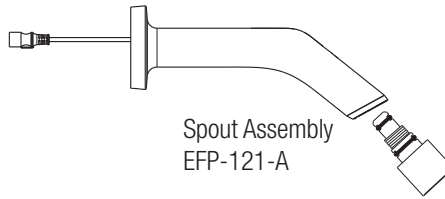

Spout Assembly
EFP-121-A

Spray Head
Carrier
EFP-1032-A



EBF-116-A

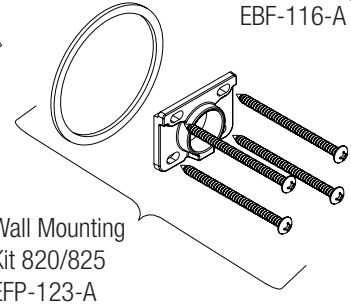

Wall Mounting
Kit 820/825
EFP-123-A

SPOUT ASSEMBLY

Description	Code No.	Part No.
Spout Assembly EBF-825 /ETF-820	03150015	EFP-121A
Sprayhead Carrier Assembly CP	0315265	EFP-1032A
Wall Mounting Kit 825/820	33620005	EFP-123A
Sensor and Cable Assembly	3315382	EFP-116A

SPRAYHEAD OPTIONS

Description	Type	Code No.	Part No.
0.35 GPM/1.3 Lpm	MLM	3362005	EFP-119
0.5 GPM/1.9 Lpm	MLM	3362001	EFP-120

BELOW DECK ASSEMBLIES

Description	Code No.	Part No.
Control Box No Turbine	0367039	EFP-39-A
Control Box Turbine 0.5 gpm	0367040	EFP-40-A
Control Box Turbine 1.5 gpm	0367011	EFP-11-A
Quick Connect Spout Hose 36"	0315322	EFP-1022
Control Box Cover w/Screw	0367010	EFP-10-A
Solenoid Assembly	0367103	EFP-103-A
Battery Pack	3324113	EFX-8-A
Double Inlet Tee Filter Assembly	0367028	EFP-28-A
BDM & Single Inlet Tee Filter Assembly Kit	0367099	EFP-99-A
BDT & Single Inlet Tee Filter Assembly Kit	0367100	EFP-100-A
Replacement Filter Pack-(5) Filter (5) Large O-rings (5) Small O-rings	0367101	EFP-101-A
24 VAC Power Harness Assembly	0367098	EFP-98-A
110V/6 VDC Power Supply	0362006	SFP-6
100-240 VAC/6 VDC Power Supply	0362016	SFP-36
120/24 VAC Power Supply	0365534PK	ETF-233
120/24 VAC Power Supply (Canada) Plug-in	0365879	ETF-416
120/24 VAC Power Supply (Box Mount)	0345370PK	EL-248-40
Extension Cable	0362017	SFP-37
Splitter Cable	0362018	SFP-38
Gang Adapter Kit	0362035	SFP-35-A
Faucet to Module Ext. Cable*	0367113	EFP-113-A



EFP-39-A
EFP-40-A
EFP-11-A

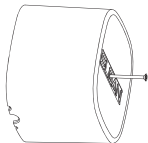

EFP-10-A
Cover and Screw ONLY



EFX-8-A



EFP-103-A

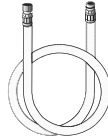

EFP-1022



SFP-6



SFP-36



SFP-37



SFP-38



EFP-98-A



EL-248-40



ETF-233



ETF-416

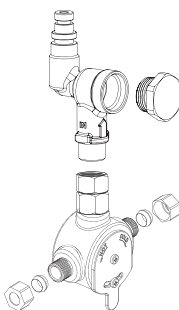

EFP-99-A

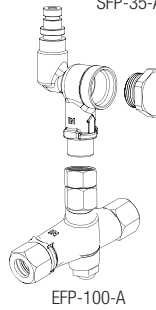

EFP-100-A

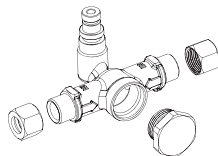

EFP-28-A



EFP-101-A

Optima® EBF-825/ETF-820 Faucets

Parts & Accessories

TROUBLESHOOTING INSTRUCTIONS FOR OPTIMA SENSOR ACTIVATED LAVATORY FAUCETS WITH THE NEW OPTIMA CONTROL BOXES AND THE SLOAN CONNECT SMARTPHONE APP.

NOTE: To automatically check battery strength, troubleshoot, diagnose and report faucet issues with a wireless device, use the Sloan SmartPhone APP. The APP is available free-of-charge at the Apple iPhone APP store for iOS devices or the Google Play APP store for Android devices. For more information about the APP and its capabilities please visit Sloan.com.

FAUCET TROUBLESHOOTING GUIDE

LED indicator light in the IR (infrared) sensor is red.

- A. Battery power is low.
Install four (4) new AA sized alkaline batteries. Check that the orientation of each battery matches the positive (+) and negative (-) symbols shown in the bottom of the battery compartment. Re-attach battery compartment to control module. Green LED will illuminate. If the Green LED does not illuminate, remove battery compartment for 10 seconds and return into place.

Faucet DOES NOT function.

- A. Batteries not installed or are exhausted.
Install four (4) AA sized alkaline batteries. Check that the orientation of each battery matches the positive (+) and negative (-) symbols shown in the bottom of the battery compartment. Reattach battery compartment to control module. Green LED will illuminate. If the Green LED does not illuminate, remove battery compartment for 10 seconds and return into place.
- B. Power Cable not installed (Hardwire models).
Install power cable and check connection.
- C. Sensor Cable not installed.
Install sensor cable and check connection. Confirm connection guide markings are aligned.
- D. Sensor range is set too short and is not detecting the target.
Increase sensor detection range.

Sensor is activated but faucet DOES NOT deliver water.

- A. Faucet has initiated its adaptive sensing calibration program.
Wait 60 seconds before activating faucet.
- B. Solenoid Cable not connected.
Check solenoid cable connection. Confirm connection guide markings are aligned.

Sensor Range Requires Manual Adjustment.

Sensor Range is measured in units from 1 to 5, with 1 being closest to the faucet and 5 being farthest from the faucet. The factory default Sensor Range is 3.

- A. To determine what the current Sensor Range setting is, press the red "Sensor" button on the upper right hand corner of the Optima Control Box for 1 second. Five seconds after pressing the button, the green LED beside it will blink to indicate the Sensor Range setting. For example, if it is set at 2, the green LED will blink 2 times.
- B. To adjust the Sensor Range, press and hold the red "Sensor" button for three seconds and release once the green LED comes on to indicate that you are in Sensor Range adjustment mode. Then press the "Sensor" button one second at a time for however many times you wish to increase the range. For example, if the Sensor Range is set at 2 and you wish to increase it to 4, press the "Sensor" button two times for one second each time..
- C. If you wish to decrease the Sensor Range, follow the same procedure to enter into Sensor Range adjustment mode, and then press the "Sensor" button one second at a time. The button is designed to go up to 5 units and then back down to 1 unit. For example, if the Sensor Range is set at 4 and you wish to decrease it to 2, press the "Sensor" button three times for one second each time.
- D. To conform your changes, wait 5 seconds and then press the red "Sensor" button on the upper right hand corner of the Optima Control Box for 1 second. Five seconds after pressing the button, the green LED beside it will blink to indicate the Sensor Range setting. For example, if it is now set at 2, the green LED will blink 2 times.

Solenoid produces an audible "CLICK" when an object is placed in the detection zone of the sensor but NO water flows.

- A. Water supply to faucet is not open.
Open supply stop(s).
- B. Inlet fitting filter is clogged.
Remove, clean, and reinsert. Replace with EBF1004 solenoid filter kit if necessary.
- C. Aerator or spray head is clogged.
Remove, clean, and reinsert.

Optima® EBF-825/ETF-820 Faucets

Parts & Accessories

Solenoid valve DOES NOT produce an audible “CLICK” and NO water flows. Green LED illuminates when batteries installed.

- A. Solenoid valve module is not working properly.
Replace EFP103A solenoid valve module.

Faucet delivers only a slow flow or dribble when sensor is activated.

- A. Water supply valve is partially closed.
Open the supply stop(s) completely.
- B. Inlet fitting filter is clogged.
Remove, clean, and reinsert. Replace with EFP101A replacement filter kit if necessary.
- C. Aerator or spray head is clogged.
Remove, clean, and reinsert.

Faucet DOES NOT stop delivering water or continues to drip after user is no longer detected (automatic shut-off fails even when batteries are removed).

- A. Solenoid valve seat is dirty.
Remove, clean, and reinsert solenoid filter. Activate faucet several times to flush out dirt.
- B. Sensor range is set too long and is detecting the sink or some other object.
Reduce sensor detection range.
- C. Solenoid valve module is not working properly.
Replace EFP103A solenoid valve module.

The water temperature is too hot or too cold on a faucet connected to hot and cold supply lines with inlet filter fitting.

- A. Supply stops are not adjusted properly.
Adjust supply stops.

NOTE: For some systems, a thermostatic mixing valve may be required

SLOAN CONNECT APP FAQs

How do I connect my faucet to the Sloan mobile app?

To connect your faucet to the Sloan mobile App, you must complete the following steps:

1. Turn on your smartphone's Bluetooth.
2. Open the Sloan mobile app.
3. Complete all Sign In fields and agree to the End User License Agreement and Terms of Use.
4. Activate your faucets Bluetooth transmitter by slowly waving your hand underneath the faucet three (3) times within ten (10) seconds. Note: water will run during this process.
5. When your faucets Bluetooth transmitter is activated, the Sloan mobile app will display your faucet.
6. Select your faucet to confirm and connect to the Sloan mobile app.

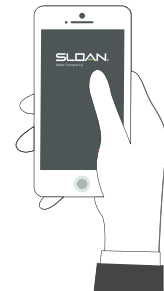

Can I still use my app and faucet if there is no internet connection?

Yes. The Sloan Connect App and faucet are designed to work in offline mode. All connectivity occurs via Bluetooth, which does not require an internet connection. If your phone is running Android 7, there is a built-in feature to prevent abusive BLE scanning. This change prevents an app from stopping and starting BLE scans more than 5 times in a window of 30 seconds. If this app does not detect any faucet and your phone is running Android 7, just exit the app and restart the app 30 seconds later.

My faucet is not showing in advertised devices.

Please be sure your Sloan Optima Control Box has power. To do this, remove the cover with the single screw in the center. Check there are no loose or disconnected wires and ensure the batteries are properly installed. Then repeat the connection process. If you are still experiencing issues, contact Sloan.

How do I save and load settings?

Each time you update settings on a faucet, they are stored in the app. If you would like to load the settings from a previous faucet to a new faucet, connect to that faucet and select the “Load Previous Settings”. This will display a dialogue box showing the previous settings. Click “Confirm” to load those settings into the app, then select “Apply Settings To Faucet” button at the bottom of your dashboard.

Why is the dashboard photo of my faucet not correct?

Each Sloan faucet type has several images associated with it. Use the left and right arrows to view the different faucet images.

How can I use the Sloan Connect App to save information about a specific faucet, like its location?

Select the “Notes” option from the main App screen and use this feature to include up to 120 characters worth of information.

When assistance is required, please contact Sloan Technical Support at:

1-888-SLOAN-14 (1-888-756-2614) (USA only) or +1-847-671-4300 (all other locations), or visit sloan.com

OLD Optima® EBF-85/EBF-187 Faucets
(Prior to 8-1-2018)

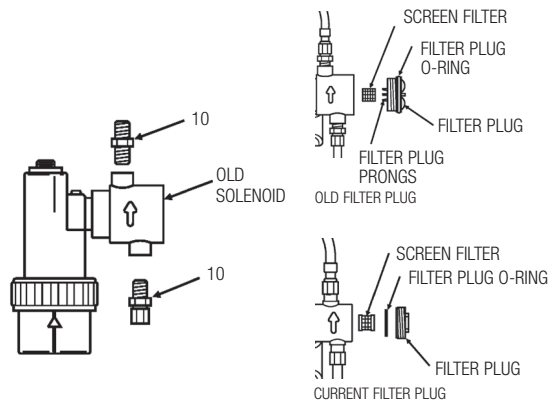
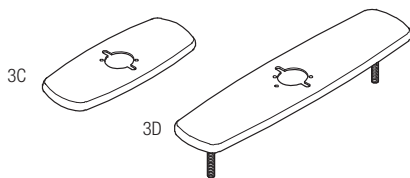
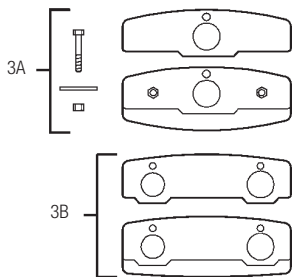
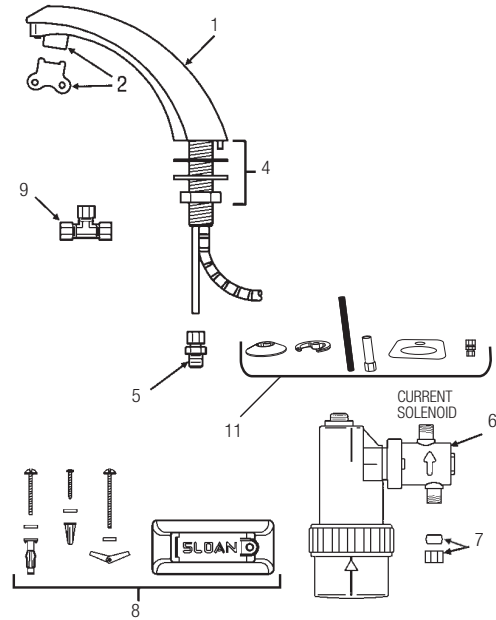

PARTS LIST—EBF-85/EBF-187 FAUCET

Item No.	Code No.	Part No.	Description
1.	3315016	EBF-10-A	Faucet and Sensor Assembly (EBF-85)
	0315112PK	EBF-170-A	Faucet and Sensor Assembly (EBF-187 with CP Metal Throat Plate)
	3315122	EBF-1009-A	Fiber Optic Sensor Cable Assembly Only (replaces EBF-12-A and EBF-179-A includes lens holder)
2.	3365091	ETF-1021-A	0.5 gpm (1.9 Lpm) Spray Head with Key (female thread)
	3365090	ETF-1022-A	2.2 gpm (8.3 Lpm) Aerator Spray Head with Key (female thread)
	3365161	ETF-1028-A	1.5 gpm (5.7 Lpm) Laminar Flow Spray Head with Key (female thread)
	3365755	ETF-1038-A	0.35 gpm (1.3 Lpm) Multi-Lam Spray Head VR
	0305927	ETF-435	Replacement Key ONLY
3A.	3365466	ETF-295-A	4" (102 mm) Centerset Trim Plate Kit for Faucet (Faucet Only) includes two (2) Nuts, two (2) Hex Screws, two (2) Flat Washers, Single Hole Cover Plate, and CP Base Plate
3B.	3365467	ETF-299-A	4" (102 mm) Centerset Trim Plate Kit for Faucet with Optional Mixing Valve includes two (2) Nuts, two (2) Hex Screws, two (2) Flat Washers, Dual Hole Cover Plate, and CP Base Plate
3C.	3365468	ETF-312-A	4" (102 mm) Centerset Trim Plate Kit for EBF-187 Faucet includes Back-up Spacer, Self-tapping Screw and CP Single Hole Trim Plate Assembly
3D.	3365024	ETF-510-A	8" (203 mm) Centerset Trim Plate Kit for EBF-85 or EBF-187 Faucet; includes two (2) Finger Nuts, two (2) Washer Gaskets, two (2) Fender Washers, Base Gasket, Back-up Spacer and CP Single Hole Trim Plate Assembly
4.	0305626	ETF-290-A	Faucet Mounting Kit includes Rubber Gasket, Mounting Washer, Mounting Nut, and Compression Fitting Connector
5.	0305736	ETF-297	1/4" to 3/8" Compression Fitting Connector
6.	3315111	EBF-11-A	Solenoid Valve Module Assembly includes Solenoid Enclosure, Solenoid Body, and Filter Cap - 4 "C" batteries (not included)
	3315009	EBF-1001-A	Solenoid Filter Replacement Kit for old solenoid includes Filter Screen Assembly and O-ring
	3315028	EBF-1004-A	Solenoid Filter Replacement Kit for current solenoid includes Filter Screen Assembly and O-ring
	3315051	EBF-1005-A	Filter Cap Assembly for old solenoid includes metal Filter Cover and O-ring - DISCONTINUED
7.	3315029	EBF-113	Single Supply Solenoid Kit
	3315001	EBF-16-A	Single Supply Solenoid Kit with Ferrule Compression Nut DISCONTINUED
8.	3315014	EBF-25-A	Mounting Bracket Kit includes Base Plate, Wall Bracket Base, Wall Bracket, Mounting Screw, Self-tapping Screw, two (2) Wood Screws plus Washers and Plastic Anchors, two (2) Screws plus Washers and Toggle Nuts, two (2) Screws plus Washers and Hollow Wall Anchors
9.	3365461	ETF-617-A	Bak-Chek® "T" Assembly
10.	0315004	EBF-17	3/8" to 1/4" Compression Fitting Connector - DISCONTINUED
11.	0365457	ETF-806A	Mounting HW Kit — = Not shown in illustration

OLD Optima® EBF-85/EBF-187 Faucets (Prior to 8-1-2018)

TROUBLESHOOTING GUIDE

1. Module emits audible “BEEPS” when activated.

- A. Battery power is nearly exhausted. To ensure proper operation, insert four (4) new C-size batteries. Check that the orientation of each battery matches the positive (+) and negative (–) symbols shown in the bottom of the battery compartment. Reattach battery compartment to control module.

2. Sensor is activated but faucet DOES NOT deliver water.

INDICATOR: Module DOES NOT produce audible “BEEPs”.

- A. Battery power is fully exhausted. To ensure proper operation, insert four (4) new C-size batteries. Check that the orientation of each battery matches the positive (+) and negative (–) symbols shown in the bottom of the battery compartment. Reattach battery compartment to control module.
- B. Batteries are not installed properly. Check that the orientation of the batteries match the positive (+) and negative (–) symbols shown in the bottom of the battery compartment. Reattach the battery compartment to the control module.
- C. Solenoid valve module is not working properly. Replace EBF-11-A solenoid valve module.

INDICATOR: Module produces audible “BEEPs” when batteries are installed and after 30-second calibration procedure, but NOT when a target is placed in the detection zone of the Sensor.

- D. Fiber optic cable is not connected correctly to solenoid valve module or was not connected when batteries were installed. Reconnect fiber optic cable to solenoid valve module. Open battery compartment to reset electrical system. Check that the orientation of each battery matches the positive (+) and negative (–) symbols shown in the bottom of the battery compartment. Reattach the battery compartment to the control module.
- E. Fiber optic cable is not working properly. Replace EBF-1009-A sensor cable, or EBF-10-A faucet/sensor assembly.
- F. Solenoid valve module is not working properly. Replace EBF-11-A solenoid valve module.

INDICATOR: Module produces audible “BEEPs” when a target is placed in the detection zone of the sensor and solenoid valve produces an audible “CLICK”, but NO water flows.

- G. Water supply to faucet is not open. Open supply stop(s).
- H. Bak-Chek® is installed backwards. Reinstall Bak-Chek(s).
- I. Solenoid filter is clogged. Remove, clean, and reinsert. Replace with EBF-1001-A or EBF-1004-A solenoid filter kit if necessary.
- J. Aerator or spray head is clogged. Remove, clean, and reinsert.

INDICATOR: Module produces audible “BEEPs” when a target is placed in the detection zone of the sensor, but solenoid valve DOES NOT produce an audible “CLICK” and NO water flows.

- K. Solenoid valve module is not working properly. Replace EBF-11-A solenoid valve module.

3. Faucet delivers only a slow flow or dribble when sensor is activated.

- A. Water supply valve is partially closed. Open the supply stop(s) completely.
- B. Solenoid filter is clogged. Remove, clean, and reinsert. Replace with EBF-1001-A or EBF-1004-A solenoid filter if necessary.
- C. Aerator or spray head is clogged. Remove, clean, and reinsert.

4. Faucet DOES NOT stop delivering water or continues to drip after user is no longer detected (automatic shut-off fails even when batteries are removed).

- A. Solenoid valve has been connected backwards. Disassemble solenoid valve compression fittings at the inlet and outlet positions. Water should flow from inlet through the solenoid valve to outlet according to the direction shown by the arrow on the side of the solenoid valve. Reconnect the fittings in the correct orientation.
- B. Solenoid valve seat is dirty. Remove, clean, and reinsert solenoid filter. Activate faucet several times to flush out dirt.
- C. Solenoid valve is dirty. Backflush by reversing water flow (opposite to the direction shown by the arrow on the side of the solenoid valve) through the solenoid valve. Reconnect the compression fittings in the correct orientation. Activate faucet.
- D. Solenoid valve module is not working properly. Replace EBF-11-A solenoid valve module.

5. The water temperature is too hot or too cold on a faucet connected to hot and cold supply lines with two Bak-Chek's.

- A. Supply stops are not adjusted properly. Adjust supply stops.
- B. One Bak-Chek is installed backwards. Reinstall Bak-Chek.

NOTE: For some systems, a thermostatic mixing valve may be required.

BATTERY REPLACEMENT

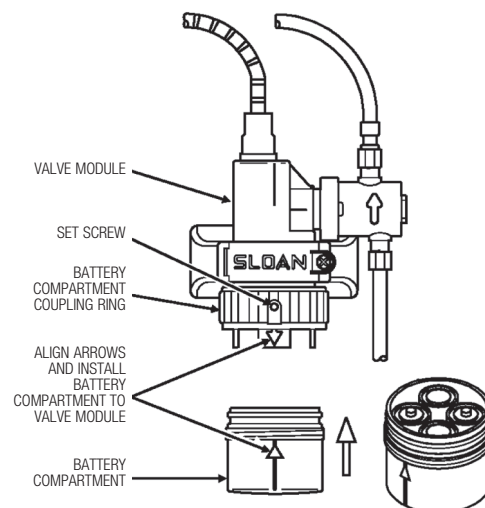

SOLENOID VALVE CHANGES

The current solenoid (in production since May 1998) has MALE inlet and outlet connections. The current style filter plug has a metal filter cap that can be removed with a 5/8" wrench. The older solenoid valve (shown on the left) can be identified by FEMALE inlet and outlet connections. These require EBF-17 compression fittings (part 10 shown on the left). This older style solenoid has either a plastic or a replacement brass filter cap. Remove the older brass filter cap with a 7/16" or 1/2" hex wrench. Replace the old style filter cap.

OLD Optima® ETF-80/ETF-880 Faucets

(Prior to 8-1-2018)

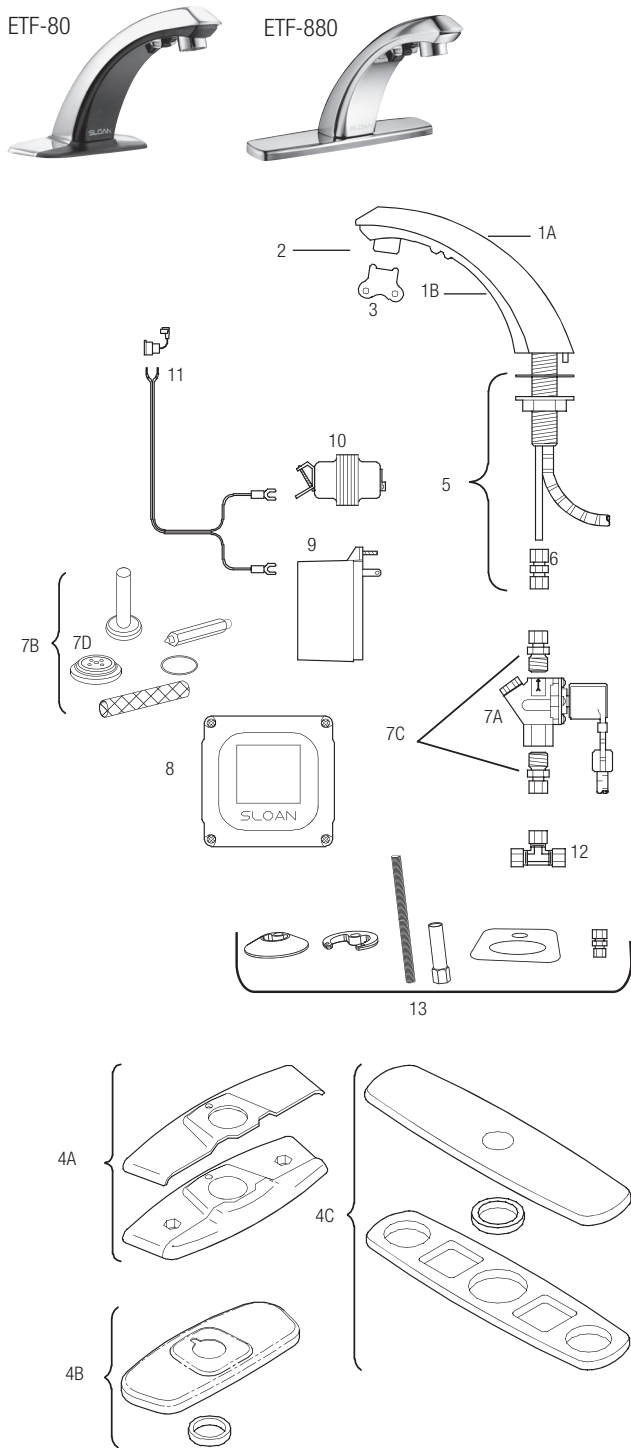

PARTS LIST—ETF-80 AND ETF-880 FAUCETS

Item No.	Code No.	Part No.	Description
1A.	0305613	ETF-250-A	Faucet/Sensor Assembly (ETF-80)
	0365054	ETF-625-A	Faucet/Sensor Assembly (ETF-880)
1B.	3365523	ETF-631-A	Sensor Assembly Only (for Faucets manufactured after 10/2003, identified by an all white Sloan name on throat plate) (ETF-80). For ETF-80 faucets prior to 10/2003 (identified by a white and red Sloan name on throat plate) sensor assembly discontinued. Use ETF-250 faucet/sensor assembly.
DISCONTINUED/ETF-1031 Repair Kit Throat Plate and Sensor (ETF-880)			
2.	3365091	ETF-1021-A	0.5 gpm (1.9 Lpm) Spray Head with Key (female thread)
	3365090	ETF-1022-A	2.2 gpm (8.3 Lpm) Aerator Spray Head with Key (female thread)
	3365161	ETF-1028-A	1.5 gpm (5.7 Lpm) Laminar Flow Spray Head with Key (female thread)
	3365755	ETF-1038-A	0.35 gpm (1.3 Lpm) Multi-Lam Spray Head VR
3.	0305927	ETF-435	Replacement Key ONLY
4A.	3365466	ETF-295-A	4" (102 mm) Centerset Trim Plate Kit for Faucet (Faucet Only) includes two (2) Nuts, two (2) Hex Screws, two (2) Flat Washers, Single Hole Cover Plate, and CP Base Plate (ETF-80)
—	3365467	ETF-299-A	4" (102 mm) Centerset Trim Plate Kit for Faucet with Optional Mixing Valve includes two (2) Nuts, two (2) Hex Screws, two (2) Flat Washers, Dual Hole Cover Plate, and CP Base Plate (ETF-80)
4B.	3365473	ETF-662-A	4" (102 mm) Centerset Trim Plate Kit (CP) (ETF-880)
4C.	3365024	ETF-510-A	8" (203 mm) Centerset Trim Plate Kit includes two (2) Finger Nuts, two (2) Washer Gaskets, two (2) Fender Washers, Base Gasket, Back-up Spacer and CP Single Hole Trim Plate Assembly (CP) (ETF-880)
5.	0305626	ETF-290-A	Faucet Mounting Kit includes Rubber Gasket, Mounting Washer, Mounting Nut, and 4439071 Compression Fitting Connector
6.	0305736	ETF-297	1/4" to 3/8" Compression Fitting Connector
7A.	0305849	ETF-370-A	24 VAC Solenoid Valve Assembly includes 18" (457 mm) armored Cable and two (2) Terminal Housings
7B.	3305577	ETF-1009-A	Solenoid Valve Repair Kit includes Replacement Filter, Guide, Armature Spring, Diaphragm and Washer
7C.	3365676	ETF-437-A	Single Solenoid Supply Kit includes, two (2) Compression Fittings (Supplied only with complete faucet)
7D.	3375003	MCR-1003-A	Diaphragm only
8.	3365000	ETF-450-A	Control Module Assembly includes splashproof Junction Box and Junction Box Mounting Kit
9.	0365534	ETF-233	120V/35VA Plug-In Transformer
10.	0345370	EL-248-40	24V/40 VA Box Mount Transformer
11.	0365001	ETF-458-A	Input Power Cable (Transformer to Control Module) includes Strain Relief and two (2) Terminal Crimp Connectors
12.	3365461	ETF-617-A	Bak-Chek® Tee Assembly
13.	0365457	ETF-806A	Mounting HW Kit
—	3305560	ETF-1006-A	Repair Kit for old-style ETF-80 Faucets (manufactured before 1992) includes Hex Screw, 5/64" Hex Wrench, Cable Assembly, Hose Clamp, 5-connector Housing, Key for Spray Heads, Access Plate/Sensor Assembly, and Control Module Assembly – DISCONTINUED

OLD-STYLE FAUCETS

ETF-80 faucets manufactured before 1992 had all their electronic circuitry located within the body of the spout.

Replacement parts (including sensor components) are available in repair kits ETF-1006-A. – **DISCONTINUED**

OLD Optima® ETF-80/ETF-880 Faucets (Prior to 8-1-2018)

TROUBLESHOOTING GUIDE

1. No water is delivered when faucet is activated.

INDICATOR: If no LED lights illuminate:

- A. No electricity is being supplied to faucet. Ensure that the main power is turned "ON". Check all transformer, sensor, solenoid, and cable connections. Make sure that transformer is supplying 24 VAC (Volts AC). If no voltage is detected, replace transformer.
- B. There is an electrical system malfunction. Reset electrical system. Unplug Sensor connection. Disconnect power to circuit for ten (10) seconds. Reconnect.

INDICATOR: If the GREEN LED illuminates when power is reconnected:

- C. There is a short in the sensor. Replace sensor. Refer to individual faucet parts diagram for appropriate sensor assembly. **NOTE:** GREEN LED may illuminate immediately after sensor disconnection.
- D. There is a short in the solenoid or solenoid cable. Replace ETF-370-A solenoid.

INDICATOR: If the GREEN LED does NOT illuminate when power is reconnected:

- E. There is an electrical system malfunction. Reset electrical system. Unplug sensor connection. Disconnect power to circuit for ten (10) seconds. Reconnect.
- F. The control module circuit is not working properly. Replace ETF-450-A control module.

INDICATOR: If GREEN LED illuminates AND changes to RED when hands are in the sensor's detection zone AND the RED solenoid LED illuminates:

- G. Water supply stop(s) may be partially closed. Open stop(s) if closed.
- H. Debris is clogging solenoid filter. Shut off water supply. Remove, clean and reinstall solenoid filter.

INDICATOR: If GREEN LED illuminates AND changes to RED when hands are placed in the sensor's detection zone AND the RED solenoid LED flickers with a vibrating/clicking noise heard inside the module: Note: Applies only to REVISION 2 MODULES.

- I. There is a direct short in the solenoid or solenoid cable. Replace with ETF-370-A solenoid.

INDICATOR: If GREEN/RED LED illuminates AND changes to RED when hands are NOT located in the sensor's detection zone BUT the RED solenoid LED (in upper left corner of circuit) does NOT illuminate:

- J. Sensor range is set too long and is detecting the sink. Reduce sensor detection range.
- K. Sensor is not working properly. Replace sensor. Refer to individual faucet parts diagram for appropriate sensor assembly.

INDICATOR: If GREEN LED illuminates BUT does NOT change to red when hands are placed in the sensor's detection zone:

- L. Sensor range is set too short. Increase sensor detection range.
- M. Sensor is not working properly. Replace sensor. Refer to individual faucet parts diagram for appropriate sensor assembly.

2. Sensing range is too short.

- A. Extended range sensitivity is required. Dip switch number 4 should be in the "DOWN" (extended range sensitivity) position. Increase range

by adjusting range potentiometer clockwise (yellow phillips screw in blue base).

- B. Faucet has surgical bend gooseneck spout. For long range use (recommended for surgical bend gooseneck spout faucet models), remove range jumper from upper right hand corner of circuit board. Adjust range potentiometer. **NOTE:** Applies only to REVISION 2 MODULES.

3. Faucet activates by itself (false triggers).

- A. Sensor range is set too long. Decrease range by adjusting range potentiometer counterclockwise. If necessary, flip dip switch number 4 into the "UP" (reduced range sensitivity) position. Check surroundings for factors that contribute to sensor range detection problems (bright lights, highly reflective surfaces, sunlight, etc.).

4. Faucet delivers very low flow or just a dribble.

- A. Water supply stop(s) may be partially closed. Open stop(s).
- B. Debris is clogging solenoid filter. Shut off water. Remove, clean, and reinstall solenoid filter.
- C. Solenoid is worn or not working properly. Rebuild with ETF-1009-A solenoid repair kit or replace ETF-370-A solenoid.
- D. Debris is clogging faucet aerator or spray head. Shut off water. Use key if required to remove. Then clean and reinstall aerator or spray head.

5. Faucet DOES NOT stop delivering water or continues to drip after user is no longer detected (even after power to the module has been disconnected).

- A. Solenoid valve is installed backward. Disconnect solenoid. Reconnect solenoid with water flow towards the faucet (see arrow on solenoid).
- B. Debris is clogging solenoid. Remove and clean solenoid operator. If necessary, rebuild with ETF-1009-A repair kit.
- C. Seat in solenoid valve body is damaged or pitted. Replace with ETF-370-A solenoid.

**When assistance is required, please contact
Sloan Technical Support at: 1-888-SLOAN-14 (1-888-756-2614).**

OLD Optima® EBF-615/EBF-650 Faucets
(Prior to 8-1-2018)



EBF-615

EBF-650

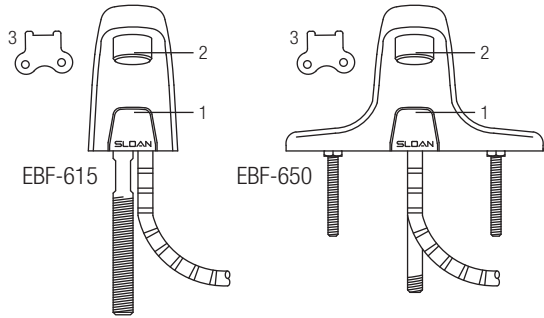

EBF-615

EBF-650

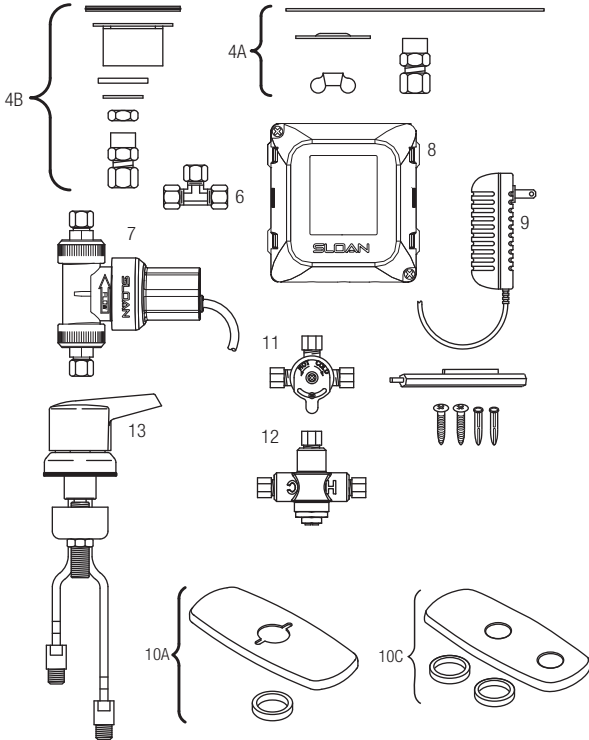

10B
10E

10D

PARTS LIST—EBF-615 AND EBF-650 FAUCETS

Item No.	Code No.	Part No.	Description
1.	0365400	ETF-749-A	Sensor Only
2.	3365092	ETF-1023-A	0.5 gpm (1.9 Lpm) Spray Head with Key (male thread)
	3365093	ETF-1024-A	2.2 gpm (8.3 Lpm) Aerator Spray Head with Key (male thread)
	3365162	ETF-1029-A	2.2 gpm (8.3 Lpm) Laminar Flow (male thread)
	3365756	ETF-1039-A	0.35 gpm (1.3 Lpm) Multi-Lam Spray Head VR
3.	0305927	ETF-435	Replacement Key Only for ETF-1023-A 0.5 gpm (1.9 Lpm) Spray Head and ETF-1024-A 2.2 gpm (8.3 Lpm) Aerator Spray Head
4A.	3365088	ETF-546-A	Faucet Mounting Kit for EBF-650 includes Base Gasket, two (2) Slotted Mounting Washers, two (2) Wing Nuts and ETF-547 Compression Fitting Connector
4B.	0315085	EBF-123-A	Faucet Mounting Kit for EBF-615 includes Base Gasket, Spacer, Washer, 9/16" Lockwasher, 1/4" NPSM Hex Nut and ETF-547 Compression Fitting Connector
5.	0365058	ETF-547	1/8" NPT Pipe to 3/8" Tube Compression Fitting Connector (female)
6.	3365461	ETF-617-A	3/8" Bak-Chek® Tee Compression Fitting
7.	0365758	ETF-740-A	6 VDC Solenoid Valve Assembly
7A.	0365774	ETF-742-A	Solenoid with armored cable and wire only (no valve assembly)
8.	0365752	ETF-735-A	Control Module - 4 "AA" Batteries (not included)
9.	0362006	SFP-6	110 VAC/6 VDC Plug-In Adapter
—	0365838	ETF-1003	36" Extension Cable (Optional)
OPTIONAL TRIM PLATES			
10A.	3365302	ETF-607-A	4" (102 mm) Centerset Trim plate for EBF-625
10B.	3365303	ETF-608-A	8" (204 mm) Centerset Trim Plate for EBF-625
10C.	3326012	MIX-101-A	4" (102 mm) Centerset Trim plate for EBF-625 with optional mixing Valve
10D.	3326017	MIX-106-A	8" (204 mm) Centerset Trim plate for EBF-625
10E.	3365119	ETF-578-A	8" (204 mm) Centerset Trim plate for EBF-655
OPTIONAL MIXING VALVES			
11.	3326009	MIX-60-A	Below Deck Mechanical Water Mixing Valve (BDM Variation)
12.	0326045	MIX-135-A	Below Deck Thermostatic Water Mixing Valve (BDT Variation)
13.	3326018	MIX-110-AA	Optimix® Deck Mounted Water Mixing Valve (only available for EBF-615 faucets)

— Not shown in illustration

For parts prior to September 2008 (Old Style) (EBF-625 & EBF-655).

OLD Optima® EBF-615/EBF-650 Faucets

(Prior to 8-1-2018)

TROUBLESHOOTING GUIDE

1. Sensor LED DOES NOT function (sensor indicator light does not flash during initial 10 minute set-up mode).

A. There is no visible indicator light. Normal operation. This is a normal operating feature of the faucet.

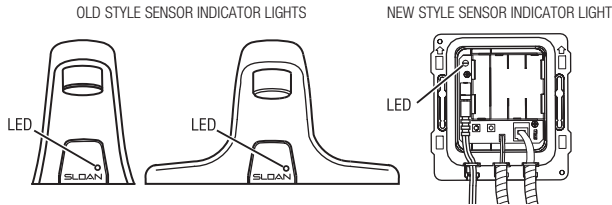

2. Faucet DOES NOT deliver any water when Sensor is activated.

INDICATOR: Solenoid valve produces audible “CLICK.”

A. Water supply stop(s) closed. Open supply stop(s) completely.

INDICATOR: Solenoid valve DOES NOT produce an audible “CLICK.”

B. Solenoid lead is not properly connected to the control module. Disconnect and reconnect solenoid lead to the control module.

C. No battery or adapter (optional) power is being supplied to sensor. Ensure that the batteries are installed properly. Check that the orientation of each battery matches the positive (+) and negative (–) symbols shown on the bottom of the battery compartment. Reinsert the batteries into the control module. Adapter (optional) is unplugged or wall receptacle has no power.

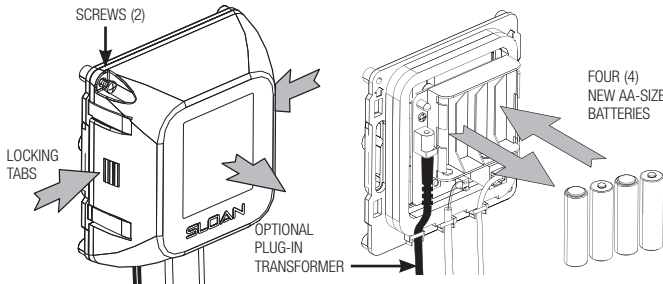

D. Sensor cable is not properly connected to the control module. Disconnect and reconnect sensor cable to the control module.

E. Sensor range is set at minimum distance. Increase sensor range. Refer to Step 9, Range adjustment in your installation instructions.

F. Control module assembly is not working properly. Replace control module assembly.

3. Faucet delivers only a slow flow or dribble when sensor is activated.

A. Water supply stop(s) partially closed. Open supply stop(s) completely.

B. Solenoid filter is clogged. Remove, clean and reinstall filter. Turn off water supply at supply stop(s). Activate faucet to relieve system pressure. Remove water supply line from inlet side of solenoid valve. Remove cap, water line fitting, gasket, filter housing and filter from solenoid valve housing. Slide filter off filter housing. Clean filter using fresh tap water only. If necessary, use a small brush to clean. Use caution while cleaning to prevent damage to filter. If any filter components are damaged, replace as necessary. Examine the gasket for wear or damage; replace if necessary. Reinstall filter on filter housing. Install filter housing, gasket, water line fitting and cap onto solenoid valve housing. Tighten cap securely. Reinstall water supply line to inlet side of solenoid valve.

C. Aerator is clogged. Remove, clean and reinstall aerator.

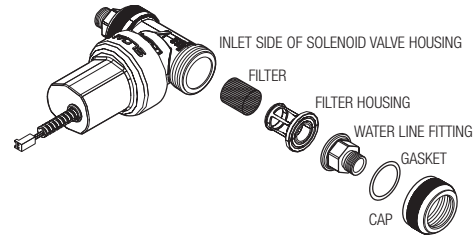

4. Faucet DOES NOT stop delivering water or continues to drip after user is no longer detected (automatic shut-off fails even when batteries are removed).

A. Solenoid valve has been connected backwards. Disconnect solenoid valve compression fittings at both the inlet and outlet positions. The water should flow from inlet through the solenoid valve to the outlet according to the direction of the arrow shown on the side of the solenoid valve. Reconnect the compression fittings in the correct orientation.

B. Solenoid valve is dirty. Backflush by reversing water flow (opposite to the direction shown by the arrow on the side of the solenoid valve) through the solenoid valve. Reconnect the compression fittings in the correct orientation. Activate faucet.

C. Solenoid valve module is not working properly. Replace solenoid valve module.

5. The water temperature is too hot or too cold on a faucet connected to hot and cold supply lines with Bak-Chek Tee.

A. Supply stops are not adjusted properly. Adjust supply stops.

NOTE: For some systems, a thermostatic mixing valve may be required.

6. The RED LED turns on in the control module (below deck).

A. One (or more) of the batteries is “dead”. To ensure proper operation, insert four (4) new AA-size batteries. Check that the orientation of each battery matches the positive (+) and negative (–) symbols shown on the bottom of the battery compartment. Reinsert batteries into the control module.

B. Upon start-up mode the control module circuitry also tests the batteries and the RED LED turns on if the battery voltage is low, no RED LED light indicates normal battery voltage.

C. If reset (initiates start up mode) button is pressed, the battery voltage is checked. If voltage is too low, product is stopped from operating and RED LED will turn on. No RED LED light indicates normal battery voltage.

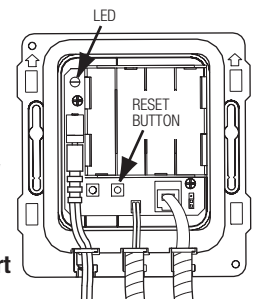

7. The GREEN LED initially turns on in the control module (below deck) during start up mode, then will not appear again.

INDICATOR: For the 1st ten minutes of operation (batteries inserted or reset button pressed) the GREEN LED will turn on when there is a target present (hands in front of sensor). After ten minutes, the GREEN LED will no longer turn on.

A. This is a normal operating feature of the faucet.

OLD Optima® EBF-625/EBF-655 Faucets

(Prior to 8-1-2018)

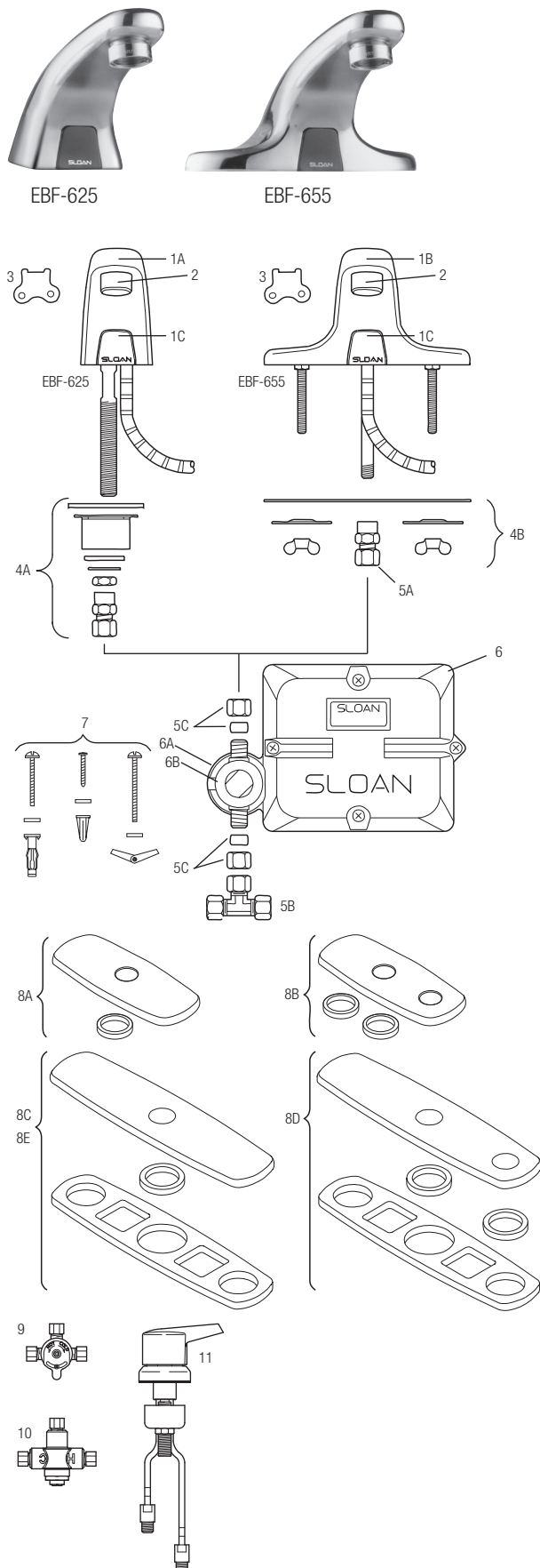

PARTS LIST—EBF-625 AND EBF-655 FAUCETS

(Known as EBF-615-/EBF-650 Prior to September 2008)

Item No.	Code No.	Part No.	Description
1A.	0315083	EBF-120-A	Pedestal Faucet Spout and Sensor assembly (EBF-625)
1B.	0315054PK	EBF-81-A	Faucet Spout and Sensor assembly (EBF-655)
1C.	0315040PK	EBF-80-A	Sensor Assembly
2.	3365092	ETF-1023-A	0.5 gpm (1.9 lpm) Spray head with Key
	3365093	ETF-1024-A	2.2 gpm (8.3 lpm) aerator Spray head with Key
	3365756	ETF-1039-A	0.35 gpm (1.3 Lpm) Multi-Lam Spray Head VR
	—	F-175-L	2.2 gpm (8.3 lpm) Laminar Flow Spray head
3.	0305927	ETF-435	Replacement Key only for ETF-1023-A and ETF-1024-A
4A.	0315085	EBF-123-A	Faucet mounting Kit for EBF-625
4B.	3365088	ETF-546-A	Faucet mounting Kit for EBF-655
5A.	0365058	ETF-547	1/8" NPT pipe to 3/8" Tube Compression Fitting Connection
5B.	3365461	ETF-617	3/8" Bak-Chek Tee Compression Fitting
5C.	3315029	EBF-113-A	Single Solenoid Supply Kit
6.	0315104	EBF-60-A	Control module assembly - 4 "C" batteries (not included)
6A.	3315254	EBF-1011-A	Solenoid replacement Kit
6B.	3315028	EBF-1004-A	Solenoid Filter replacement Kit (includes filter Screen and o-ring)
7.	3315018	EBF-79-A	Mounting hardware Kit for Control module assembly
8A.	3365302	ETF-607-A	4" (102 mm) Centerset Trim plate for EBF-625
8B.	3326012	MIX-101-A	4" (102 mm) Centerset Trim plate for EBF-625 with optional mixing Valve
8C.	3365303	ETF-608-A	8" (204 mm) Centerset Trim plate for EBF-625
8D.	3326017	MIX-106-A	8" (204 mm) Centerset Trim plate for EBF-625
8E.	3365119	ETF-578-A	8" (204 mm) Centerset Trim plate for EBF-655
OPTIONAL MIXING VALVES			
9.	3326009	MIX-60-A	Below Deck Mechanical Water Mixing Valve (BDM Variation)
10.	0326045	MIX-135-A	Below Deck Thermostatic Water Mixing Valve (BDT Variation)
11.	3326018	MIX-110-AA	Optimix® Deck Mounted Water Mixing Valve (only available for EBF-625 faucets)

— in Item No. column = Not shown in illustration
 — in Code No. and Part No. column = Not sold separately

OLD Optima® EBF-625/EBF-655 Faucets

(Prior to 8-1-2018)

TROUBLESHOOTING GUIDE

1. Faucet DOES NOT stop delivering water or continues to drip after user is no longer detected (automatic shut-off fails even when batteries are removed).

- Solenoid valve has been connected backwards. Disassemble solenoid valve compression fittings at both the inlet and outlet positions. The water should flow from inlet through the solenoid valve to the outlet according to the direction of the arrow shown on the side of the solenoid valve. Reconnect the compression fittings in the correct orientation.
- Solenoid valve is dirty. Back-flush by reversing water flow (opposite to the direction shown by the arrow on the side of the solenoid valve) through the solenoid valve. Reconnect the compression fittings in the correct orientation. Activate faucet.
- Solenoid valve module is not working properly. Replace EBF-1011-A Solenoid valve module.

2. Sensor troubleshooting LED DOES NOT function (red indicator light DOES NOT flash during set-up procedure).

- No battery power is being supplied to sensor. Ensure that the batteries are installed properly. Check that the orientation of each battery matches the positive (+) and negative (-) symbols shown on the bottom of the battery compartment. Reinsert the battery compartment into the control module.
- Insufficient battery power is being supplied to sensor. One (or more) of the batteries is "dead". To ensure proper operation, insert four (4) new "C" cell batteries. Check that the orientation of each battery matches the positive (+) and negative (-) symbols shown on the bottom of the battery compartment. Reinsert the battery compartment into the control module.
- Sensor cable is not properly inserted. Disconnect and reconnect sensor cable to the control module.
- Sensor range is set at minimum distance. Increase sensor range. Use a small philips screwdriver to turn the potentiometer screw (white screw in blue base) clockwise.
- Control module assembly is not working properly. Replace EBF-60-A control module assembly.

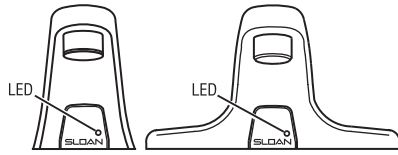

3. The water temperature is too hot or too cold on faucet connected to hot and cold water supply lines with two Bak-Chek.

- Supply stops are not adjusted properly. Adjust supply stops.
- NOTE:** A thermostatic mixing valve may be required on some systems.

4. Faucet DOES NOT deliver any water when sensor is activated.

INDICATOR: Solenoid valve produces audible "CLICK." Water supply valve is closed.

- Open the water supply.

INDICATOR: Solenoid valve DOES NOT produce an audible "CLICK."

- Disconnect and reconnect solenoid lead to the control module, if solenoid lead is not properly connected to the control module. Batteries are not installed properly. Check that the orientation of each battery matches the positive (+) and negative (-) symbols shown on the bottom of the battery compartment. Reinsert the battery compartment into the control module. The troubleshooting LED should flash RED when a user is detected.

5. Faucet delivers only a slow flow or dribble when sensor is activated.

- Water supply valve is partially closed. Completely open the supply stop(s).
- Solenoid filter is clogged. Remove, clean, and reinsert. Replace EBF-1004-A solenoid filter kit, if necessary.
- Aerator or spray head is clogged. Remove, clean, and reinsert.

BATTERY REPLACEMENT

The Sloan Optima Plus EBF-625 and EBF-655 battery powered, sensor activated lavatory faucets are furnished with four (4) "C" cell batteries that provide up to two (2) years of operation (8000 cycles per month). A flashing LED signal indicates that battery power will be depleted within one (1) month. Replace batteries with four (4) new "C" cell batteries.

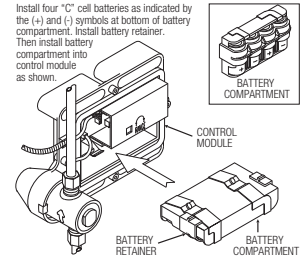

Remove the cover of the control module by unscrewing the four (4) cover screws located at the center of each side.

Remove the battery compartment from the control module by gently pulling straight out with a firm grip. Spread the ends of the battery retainer and remove it from the battery compartment. Remove the old batteries and insert four (4) fresh "C" cell batteries into the battery compartment until locked into place.

NOTE: Battery retainer MUST be installed as shown. If installed upside-down, it will not install into the control module. Reinsert the battery compartment into the control module as shown.

Place cover over the control module and use the four (4) screws provided to attach it. Cover can be installed in only orientation.

IMPORTANT: Install ALL four (4) cover screws for proper installation.

CLEAN SCREEN FILTER

Before cleaning the screen filter, turn off water supply at the supply stop(s). Activate the faucet to relieve any pressure in the system. Unscrew the filter plug and remove it from the solenoid valve housing. Carefully pull the screen filter with attached rubber seals out from the solenoid valve housing.

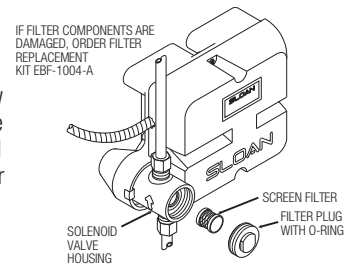

Clean the screen filter using fresh tap water only. If necessary, use a small brush to clean. Use caution while cleaning to prevent damage to the solenoid screen filter. If any filter components are damaged, order Filter Replacement Kit (EBF-1004-A).

Carefully replace the screen filter into the groove of the solenoid valve housing. Examine the filter plug o-ring for wear or damage; replace if necessary. If necessary, lubricate the filter plug o-ring with water to keep it in place in the groove of the filter plug. Screw the filter plug into the solenoid valve housing.

Turn on the water supply at the supply stop(s). Activate the faucet to purge any air from the system lines. Check for leaks and repair, as necessary.

When assistance is required, please contact Sloan Technical Support at: 1-888-SLOAN-14 (1-888-756-2614).

OLD Optima® ETF-600/ETF-610 Faucets
(Prior to 8-1-2018)



ETF-610



ETF-600

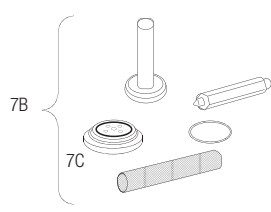
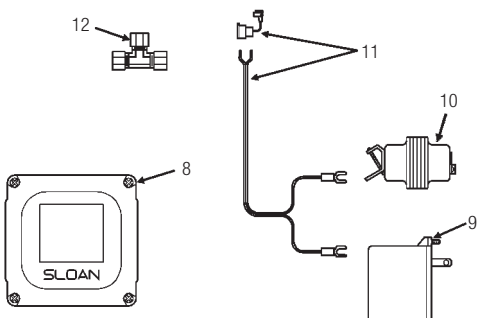
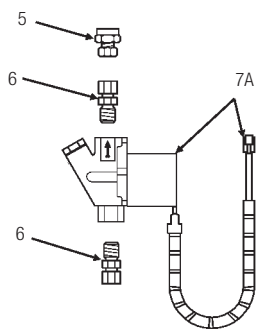
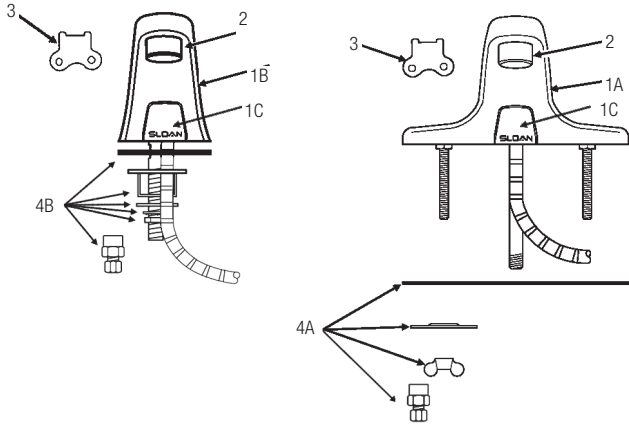

PARTS LIST—ETF-600 AND ETF-610 FAUCETS

Item No.	Code No.	Part No.	Description
1A.	0365086	ETF-543-A	Faucet and Sensor Assembly (ETF-600)
1B.	0365117	ETF-570-A	Pedestal Faucet and Sensor Assembly (ETF-610)
1C.	0365070	ETF-542-A	Sensor Module Only (for ETF-600 and ETF-610 faucets) includes 18" (153 mm) armored Cable, Shroud, and Housing for Sensor Window
2.	3365092	ETF-1023-A	0.5 gpm (1.9 Lpm) Spray Head with Key (male thread)
	3365093	ETF-1024-A	2.2 gpm (8.3 Lpm) Aerator Spray Head with Key (male thread)
	3365162	ETF-1029-A	2.2 gpm (8.3 Lpm) Laminar Flow Spray Head with Key (male thread)
	3365756	ETF-1039-A	0.35 gpm (1.3 Lpm) Multi-Lam Spray Head VR
3.	0305927	ETF-435	Replacement Key Only
4A.	3365088	ETF-546-A	Faucet Mounting Kit for ETF-600 includes Base Gasket, two (2) Slotted Mounting Washers, two (2) Wing Nuts, and Compression Fitting Connector
4B.	0315085	EBF-123-A	Faucet Mounting Kit for ETF-610 includes Spacer, Base Gasket, 1/4" NPSM Hex Nut, Washer, 9/16" Lock Washer and Compression Fitting Connector
5.	0365058	ETF-547	1/8" NPT Pipe to 3/8" Tube Compression Fitting Connector (female)
6.	3365676	ETF-437-A	Single Solenoid Supply Kit includes, two (2) Compression Fittings, Compression Nut, and Ferrule
7A.	0305849	ETF-370-A	24 VAC Solenoid Valve Assembly includes 18" (457 mm) armored Cable and two (2) Terminal Housings
7B.	3305577	ETF-1009-A	Solenoid Valve Repair Kit includes Replacement Filter, Guide, Armature Spring, Diaphragm and Washer
7C.	3375003	MCR-1003-A	Diaphragm only
8.	3365000	ETF-450-A	Control Module Assembly includes splashproof Junction Box and Junction Box Mounting Kit
9.	0365534	ETF-233	120V/35VA Plug-In Transformer
10.	0345370	EL-248-40	24V/40VA Box Mount Transformer
11.	0365001	ETF-458-A	Input Power Cable (Transformer to Control Module) includes Strain Relief and two (2) Terminal Crimp Connectors
12.	3365461	ETF-617-A	Bak-Chek® "T" Assembly

OLD Optima® ETF-600/ETF-610 Faucets (Prior to 8-1-2018)

TROUBLESHOOTING GUIDE

1. No water is delivered when faucet is activated.

INDICATOR: If no LED lights illuminate:

- A. No electricity is being supplied to faucet. Ensure that the main power is turned "ON". Check all transformer, sensor, solenoid and cable connections. Make sure that transformer is supplying 24 VAC (Volts AC). If no voltage is detected, replace transformer.
- B. There is an electrical system malfunction. Reset electrical system. Unplug sensor connection. Disconnect power to circuit for ten (10) seconds. Reconnect.

INDICATOR: If the GREEN LED illuminates when power is reconnected:

- C. There is a short in the sensor. Replace sensor. Refer to individual faucet parts diagram for appropriate sensor assembly. **NOTE:** GREEN LED may illuminate immediately after sensor disconnection.
- D. There is a short in the solenoid or solenoid cable. Replace ETF-370-A solenoid.

INDICATOR: If the GREEN LED does NOT illuminate when power is reconnected:

- E. There is an electrical system malfunction. Reset electrical system. Unplug sensor connection. Disconnect power to circuit for ten (10) seconds. Reconnect.
- F. The control module circuit is not working properly. Replace ETF-450-A control module.

INDICATOR: If GREEN LED illuminates AND changes to RED when hands are in the sensor's detection zone AND the RED solenoid LED illuminates:

- G. Water supply stop(s) may be partially closed. Open stop(s) if closed.
- H. Debris is clogging solenoid filter. Shut off water supply. Remove, clean and reinstall solenoid filter.

INDICATOR: If GREEN LED illuminates AND changes to RED when hands are placed in the sensor's detection zone AND the RED solenoid LED flickers with a vibrating/clicking noise heard inside the module: Note: Applies only to REVISION 2 MODULES.

- I. There is a direct short in the solenoid or solenoid cable. Replace with ETF-370-A solenoid.

INDICATOR: If GREEN/RED LED illuminates AND changes to RED when hands are NOT located in the sensor's detection zone BUT the RED solenoid LED (in upper left corner of circuit) does NOT illuminate:

- J. Sensor range is set too long and is detecting the sink. Reduce sensor detection range.
- K. Sensor is not working properly. Replace sensor. Refer to individual faucet parts diagram for appropriate sensor assembly.

INDICATOR: If GREEN LED illuminates BUT does NOT change to red when hands are placed in the sensor's detection zone:

- L. Sensor range is set too short. Increase sensor detection range.
- M. Sensor is not working properly. Replace sensor. Refer to individual faucet parts diagram for appropriate sensor assembly.

2. Sensing range is too short.

- A. Extended range sensitivity is required. Dip switch number 4 should be in the "DOWN" (Extended range sensitivity) position. Increase range

by adjusting range potentiometer clockwise (yellow phillips screw in blue base).

- B. Faucet has surgical bend gooseneck spout. For long range use (recommended for surgical bend gooseneck spout faucet models), remove range jumper from upper right hand corner of circuit board. Adjust range potentiometer. Note: Applies only to REVISION 2 MODULES.

3. Faucet activates by itself (false triggers).

- A. Sensor range is set too long. Decrease range by adjusting range potentiometer counterclockwise. If necessary, flip dip switch number 4 into the "UP" (reduced range sensitivity) position. Check surroundings for factors that contribute to sensor range detection problems (bright lights, highly reflective surfaces, sunlight, etc.).

4. Faucet delivers very low flow or just a dribble.

- A. Water supply stop(s) may be partially closed. Open stop(s).
- B. Debris is clogging solenoid filter. Shut off water. Remove, clean, and reinstall solenoid filter.
- C. Solenoid is worn or not working properly. Rebuild with ETF-1009-A solenoid repair kit or replace ETF-370-A solenoid.
- D. Debris is clogging faucet aerator or spray head. Shut off water. Use key if required to remove. Then clean and reinstall aerator or spray head.

5. Faucet DOES NOT stop delivering water or continues to drip after user is no longer detected (even after power to the module has been disconnected).

- A. Solenoid valve is installed backward. Disconnect solenoid. Reconnect solenoid with water flow towards the faucet (see arrow on solenoid).
- B. Debris is clogging solenoid. Remove and clean solenoid operator. If necessary, rebuild with ETF-1009-A repair kit.
- C. Seat in solenoid valve body is damaged or pitted. Replace with ETF-370-A solenoid.

When assistance is required, please contact

Sloan Technical Support at: 1-888-SLOAN-14 (1-888-756-2614).

OLD Optima® EBF-750/EBF-750-S Faucets (Prior to 8-1-2018)

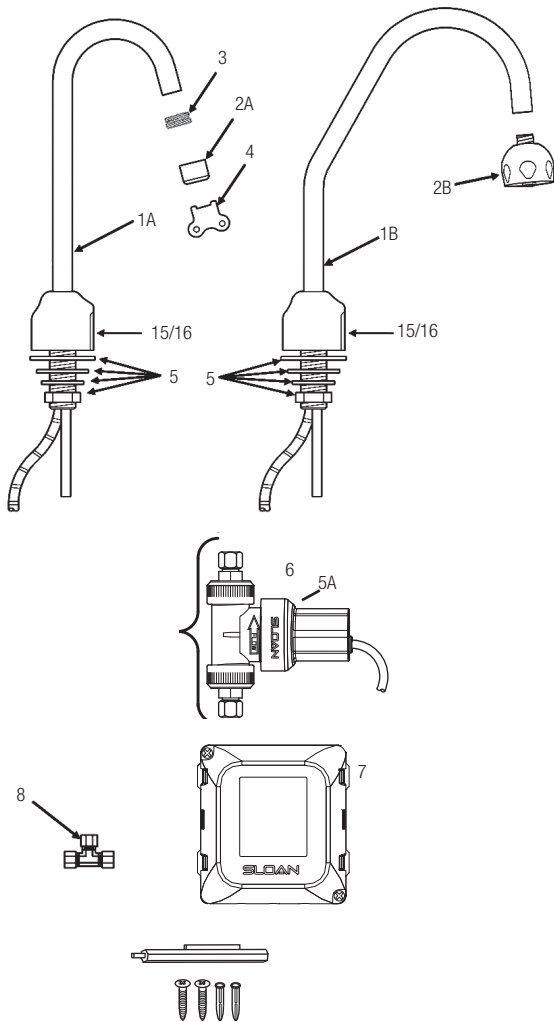

PARTS LIST—EBF-750 FAUCET

Item No.	Code No.	Part No.	Description
1A.	0315100PK	EBF-140-A	Faucet/Sensor Assembly with Standard Gooseneck Spout (EBF-750) w/ ETF-178.
1B.	0315101PK	EBF-141-A	Faucet/Sensor Assembly with Surgical Bend Gooseneck Spout (EBF-750-S) w/ ETF-178.
2A.	3365147	ETF-621-A	2.2 gpm (8.3 Lpm) Aerator Spray Head with Key (female thread)
	0365793	ETF-839	0.35 gpm (1.3 Lpm) Multi-Lam Spray Head
2B.	0328134	AC-55-A	Shower Spray Head Assembly, 2.2 gpm (8.3 Lpm)
3.	0305784	ETF-178	Adapter for Spray Heads (not required for AC-55-A Shower Spray Head)
4.	0305927	ETF-435	Replacement Key Only
5.	0365110	ETF-503-A	Spout Mounting Kit includes Rubber Gasket, Flat Washer, Lockwasher, Mounting Nut, and Union Compression Fitting
6.	0365758	ETF-740-A	6 VDC Solenoid Assembly
7.	0365752	ETF-735-A	Control Module - 4 "AA" Batteries (not included)
8.	3365461	ETF-617-A	Bak-Chek® Tee Assembly
9.	3365302	ETF-607-A	Optional 4" (102 mm) Centerset Trim Plate Kit includes Trim Plate Spacer and Single Hole Trim Plate Assembly
—.	0365838	ETF-1003	36" Extension Cable (Optional) for Sensor

For additional information about Sloan Mixing Valves or Trim Plates, consult our Installation Instructions and Maintenance Guides.

The current parts breakdown shown on the left has been in production since September 2009. For earlier EBF-650/615 faucet models, please refer to the parts breakdown below and right or consult your nearest Sloan representative.

Note: earlier faucet models are not compatible with the current models.

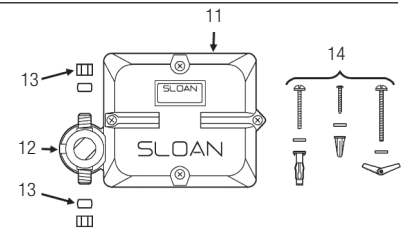

PARTS PRIOR TO SEPTEMBER 2009

11.	0315104	EBF-60-A	Control Module assembly - 4 "C" batteries (not included)
12.	0315254	EBF-1011-A	Solenoid replacement kit
13.	3315029	EBF-113-A	Single solenoid supply compression nut kit
14.	3315018	EBF-79-A	Mounting hardware kit
15.	9103292	EBF-236-A	Sensor (New Style) Replacement Kit ONLY includes Sensor Housing and Cable Assembly (Phone Jack)
16.	0315057	EBF-138-A	Sensor (Old Style) (Prior to September 2009) Replacement Kit ONLY includes Sensor Housing and Cable Assembly (Flat Wire Black Plug)

— = Not shown in illustration

Optional Trim Plate Kits

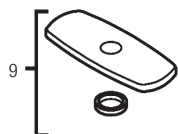

OLD Optima® EBF-750/EBF-750-S Faucets (Prior to 8-1-2018)

TROUBLESHOOTING GUIDE

1. Sensor LED DOES NOT function (sensor indicator light does not flash during initial 10 minute set-up mode).

- A. There is no visible indicator light. Normal operation. This is a normal operating feature of the faucet.

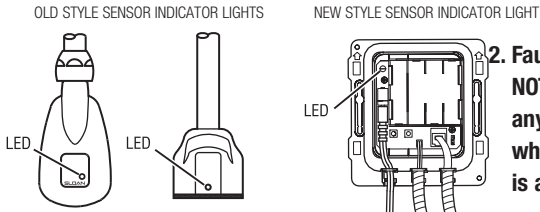

2. Faucet DOES NOT deliver any water when sensor is activated.

INDICATOR: Solenoid valve produces audible “CLICK.”

- A. Water supply stop(s) closed. Open supply stop(s) completely.

INDICATOR: Solenoid valve DOES NOT produce an audible “CLICK.”

- B. Solenoid Lead is not properly connected to the control module. Disconnect and reconnect solenoid lead to the control module.
- C. No battery or transformer (optional) power is being supplied to sensor. Ensure that the batteries are installed properly. Check that the orientation of each battery matches the positive (+) and negative (—) symbols shown on the bottom of the battery compartment. Reinsert the batteries into the control module. Transformer (optional) is unplugged or wall receptacle has no power.

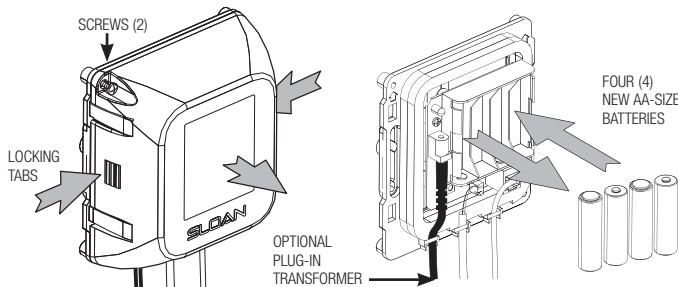

- D. Sensor cable is not properly connected to the control module. Disconnect and reconnect sensor cable to the control module.
- E. Sensor range is set at minimum distance. Increase sensor range. Refer to range adjustment in your installation instructions.
- F. Control module assembly is not working properly. Replace control module assembly.

3. Faucet delivers only a slow flow or dribble when sensor is activated.

- A. Water supply stop(s) partially closed. Open supply stop(s) completely.
- B. Solenoid filter is clogged. Remove, clean and reinstall filter. Turn off water supply at supply stop(s). Activate faucet to relieve system pressure. Remove water supply line from inlet side of solenoid valve. Remove cap, water line fitting, gasket, filter housing and filter from solenoid valve housing. Slide filter off filter housing. Clean filter using fresh tap water only. If necessary, use a small brush to clean. Use caution while cleaning to prevent damage to filter. If any filter components are damaged, replace as necessary. Examine the gasket for wear or damage; replace if necessary. Reinstall filter on filter housing. Install filter housing, gasket, water line fitting and cap onto solenoid valve housing. Tighten cap securely. Reinstall water supply line to inlet side of solenoid valve.

- C. Aerator is clogged. Remove, clean and reinstall aerator.

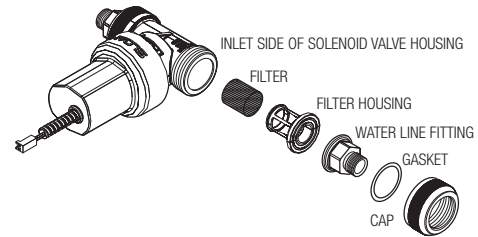

4. Faucet DOES NOT stop delivering water or continues to drip after user is no longer detected (automatic shut-off fails even when batteries are removed).

- A. Solenoid valve has been connected backwards. Disconnect solenoid valve compression fittings at both the inlet and outlet positions. The water should flow from inlet through the solenoid valve to the outlet according to the direction of the arrow shown on the side of the solenoid valve. Reconnect the compression fittings in the correct orientation.
- B. Solenoid valve is dirty. Backflush by reversing water flow (opposite to the direction shown by the arrow on the side of the solenoid valve) through the solenoid valve. Reconnect the compression fittings in the correct orientation. Activate faucet.
- C. Solenoid valve module is not working properly. Replace solenoid valve module.

5. The water temperature is too hot or too cold on a faucet connected to hot and cold supply lines with Bak-Chek® Tee.

- A. Supply stops are not adjusted properly. Adjust supply stops.

NOTE: For some systems, a thermostatic mixing valve may be required.

6. The RED LED turns on in the control module (below deck).

- A. One (or more) of the batteries is “dead”. To ensure proper operation, insert four (4) new AA-size batteries. Check that the orientation of each battery matches the positive (+) and negative (—) symbols shown on the bottom of the battery compartment. Reinsert batteries into the control module.
- B. Upon start-up mode the control module circuitry also tests the batteries and the RED LED turns on if the battery voltage is low, no RED LED light indicates normal battery voltage.
- C. If reset (initiates start up mode) button is pressed, the battery voltage is checked. If voltage is too low, product is stopped from operating and RED LED will turn on. No RED LED light indicates normal battery voltage.

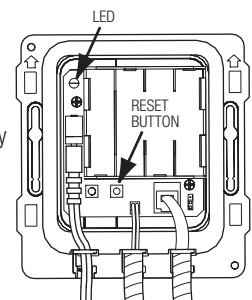

7. The GREEN LED initially turns on in the control module (below deck) during start up mode, then will not appear again.

INDICATOR: For the 1st ten minutes of operation (batteries inserted or reset button pressed) the Green LED will turn on when there is a target present (hands in front of sensor). After ten minutes, the Green LED will no longer turn on.

- A. This is a normal operating feature of the faucet.

OLD Optima® ETF-700/ETF-700-S Faucets
(Prior to 8-1-2018)

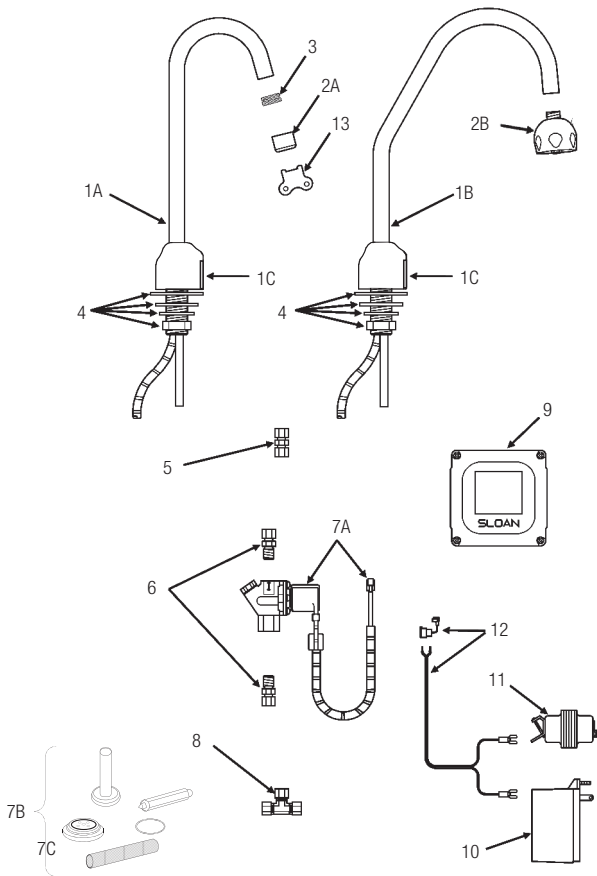

Optional Trim Plates

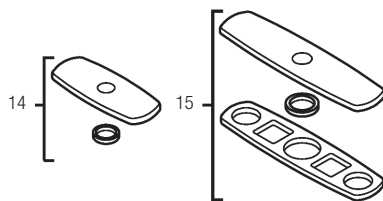

PARTS LIST—ETF-700 FAUCET

Item No.	Code No.	Part No.	Description
1A.	0365108	ETF-472-A	Faucet and Sensor Assembly with Standard Gooseneck Spout (ETF-700)
1B.	0365109	ETF-473-A	Faucet and Sensor Assembly with Surgical Bend Gooseneck Spout (ETF-700-S)
1C.	0365456PK	ETF-830-A	(NEW STYLE) Sensor Module Only includes 18" (153 mm) armored Cable, Shroud, and Housing for Sensor Window (ETF-700 and ETF-700-S Faucets)
1C.	0365028	ETF-476-A	(OLD STYLE) (Prior to 1-2009) Sensor Module Only includes 18" (153 mm) armored Cable, Shroud, and Housing for Sensor Window (ETF-700 and ETF-700-S Faucets)
2A.	0365147	ETF-621-A	2.2 gpm (8.3 Lpm) Aerator Spray Head with Key (female thread)
	0365793	ETF-839	0.35 gpm (1.3 Lpm) Multi-Lam Spray Head
2B.	0328134	AC-55-A	Shower Spray Head Assembly, 2.2 gpm (8.3 Lpm)
3.	0305784	ETF-178	Adapter for Spray Heads (not required for AC-55-A Shower Spray Head)
4.	0365110	ETF-503-A	Spout Mounting Kit Includes Rubber Washer, Flat Washer, Lockwasher, Mounting Nut, and Union Compression Fitting
5.	0365057	ETF-530	3/8" x 3/8" Union Compression Fitting (female)
6.	3365676	ETF-437-A	Single Solenoid Supply Kit includes, two (2) Compression Fittings, Compression Nut, and Ferrule
7A.	0305849	ETF-370-A	24 VAC Solenoid Valve Assembly includes 18" (457 mm) Armored Cable and two (2) Terminal Housings
7B.	3305577	ETF-1009-A	Solenoid Valve Repair Kit includes Replacement Filter, Guide, Armature Spring, Diaphragm and Washer
7C.	3375003	MCR-1003-A	Diaphragm only
8.	3365461	ET617-A	Bak-Chek® "T" Assembly
9.	3365000	ETF-450-A	Control Module Assembly includes splashproof Junction Box and Junction Box Mounting Kit
10.	0365534	ETF-233	120V/35VA Plug-In Transformer
11.	0345370	EL-248-40	24V/40VA Box Mount Transformer
12.	0365001	ETF-458-A	Input Power Cable (Transformer to Control Module) includes Strain Relief and two (2) Terminal Crimp Connectors
13.	0305927	ETF-435	Replacement Key Only
14.	3365302	ETF-607-A	Trim Plate for 4" Center-set Sink
15.	3365303	ETF-608-A	Trim Plate for 8" Center-set Sink

— = Not shown in illustration

FAUCET CABLE EXTENSION CORDS

ETF-80, ETF-500, ETF-600/ETF-610, ETF-660/ETF-770, ETF-700

0365042	ETF-1005-26	Faucet to Control Module Extension Cord; 26 inch (0.7 meter) Length – DISCONTINUED
0305861	ETF-1005-36	Faucet to Control Module Extension Cord; 36 inch (0.9 meter) Length
0305862	ETF-1005-72	Faucet to Control Module Extension Cord; 72 inch (1.8 meter) Length – DISCONTINUED
0305863	ETF-1005-108	Faucet to Control Module Extension Cord; 108 inch (2.7 meter) Length
0365838	ETF-1003-36	Solenoid to Control Module Extension Cord; 36 inch (0.9 meter) Length
0365053	ETF-1003-48	Solenoid to Control Module Extension Cord; 48 inch (1.2 meter) Length – DISCONTINUED
0365839	ETF-1003-72	Solenoid to Control Module Extension Cord; 72 inch (1.8 meter) Length – DISCONTINUED
0365840	ETF-1003-108	Solenoid to Control Module Extension Cord; 108 inch (2.7 meter) Length

OLD Optima® ETF-700/ETF-700-S Faucets (Prior to 8-1-2018)

TROUBLESHOOTING GUIDE

1. No water is delivered when faucet is activated.

INDICATOR: If no LED lights illuminate:

- A. No electricity is being supplied to faucet. Ensure that the main power is turned "ON". Check all transformer, sensor, solenoid and cable connections. Make sure that transformer is supplying 24 VAC (Volts AC). If no voltage is detected, replace transformer.
- B. There is an electrical system malfunction. Reset electrical system. Unplug sensor connection. Disconnect power to circuit for ten (10) seconds. Reconnect.

INDICATOR: If the GREEN LED illuminates when power is reconnected:

- C. There is a short in the sensor. Replace sensor. Refer to individual faucet parts diagram for appropriate sensor assembly. **NOTE:** GREEN LED may illuminate immediately after sensor disconnection.
- D. There is a short in the solenoid or solenoid cable. Replace ETF-370-A solenoid.

INDICATOR: If the GREEN LED does NOT illuminate when power is reconnected:

- E. There is an electrical system malfunction. Reset electrical system. Unplug sensor connection. Disconnect power to circuit for ten (10) seconds. Reconnect.
- F. The control module circuit is not working properly. Replace ETF-450-A control module.

INDICATOR: If GREEN LED illuminates AND changes to RED when hands are in the sensor's detection zone AND the RED solenoid LED illuminates:

- G. Water supply stop(s) may be partially closed. Open stop(s) if closed.
- H. Debris is clogging solenoid filter. Shut off water supply. Remove, clean and reinstall solenoid filter.

INDICATOR: If GREEN LED illuminates AND changes to RED when hands are placed in the sensor's detection zone AND the RED solenoid LED flickers with a vibrating/clicking noise heard inside the module: Note: Applies only to REVISION 2 MODULES.

- I. There is a direct short in the solenoid or solenoid cable. Replace with ETF-370-A solenoid.

INDICATOR: If GREEN/RED LED illuminates AND changes to RED when hands are NOT located in the sensor's detection zone BUT the RED solenoid LED (in upper left corner of circuit) does NOT illuminate:

- J. Sensor range is set too long and is detecting the sink. Reduce sensor detection range.
- K. Sensor is not working properly. Replace sensor. Refer to individual faucet parts diagram for appropriate sensor assembly.

INDICATOR: If GREEN LED illuminates BUT does NOT change to red when hands are placed in the sensor's detection zone:

- L. Sensor range is set too short. Increase sensor detection range.
- M. Sensor is not working properly. Replace sensor. Refer to individual faucet parts diagram for appropriate sensor assembly.

2. Sensing range is too short.

- A. Extended range sensitivity is required. Dip switch number 4 should be in the "DOWN" (Extended range sensitivity) position. Increase range by adjusting range potentiometer clockwise (yellow phillips screw in blue base).
- B. Faucet has surgical bend gooseneck spout. For long range use (recommended for surgical bend gooseneck spout faucet models), remove range jumper from upper right hand corner of circuit board. Adjust range potentiometer. Note: Applies only to REVISION 2 MODULES.

3. Faucet activates by itself (false triggers).

- A. Sensor range is set too long. Decrease range by adjusting range potentiometer counterclockwise. If necessary, flip dip switch number 4 into the "UP" (reduced range sensitivity) position. Check surroundings for factors that contribute to sensor range detection problems (bright lights, highly reflective surfaces, sunlight, etc.).

4. Faucet delivers very low flow or just a dribble.

- A. Water supply stop(s) may be partially closed. Open stop(s).
- B. Debris is clogging solenoid filter. Shut off water. Remove, clean, and reinstall solenoid filter.
- C. Solenoid is worn or not working properly. Rebuild with ETF-1009-A solenoid repair kit or replace ETF-370-A solenoid.
- D. Debris is clogging faucet aerator or spray head. Shut off water. Use key if required to remove. Then clean and reinstall aerator or spray head.

5. Faucet DOES NOT stop delivering water or continues to drip after user is no longer detected (even after power to the module has been disconnected).

- A. Solenoid valve is installed backward. Disconnect solenoid. Reconnect solenoid with water flow towards the faucet (see arrow on solenoid).
- B. Debris is clogging solenoid. Remove and clean solenoid operator. If necessary, rebuild with ETF-1009-A repair kit.
- C. Seat in solenoid valve body is damaged or pitted. Replace with ETF-370-A solenoid.

**When assistance is required, please contact
Sloan Technical Support at: 1-888-SLOAN-14 (1-888-756-2614).**

OLD Optima® EBF-550/EBF-550-S Faucets
(Prior to 8-1-2018)

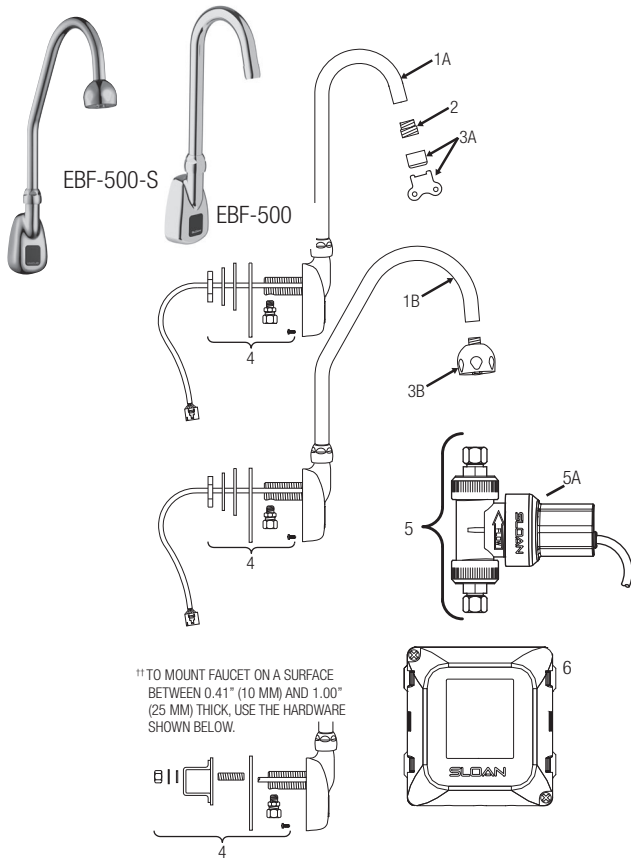

TO MOUNT FAUCET ON A SURFACE BETWEEN 0.41" (10 MM) AND 1.00" (25 MM) THICK, USE THE HARDWARE SHOWN BELOW.

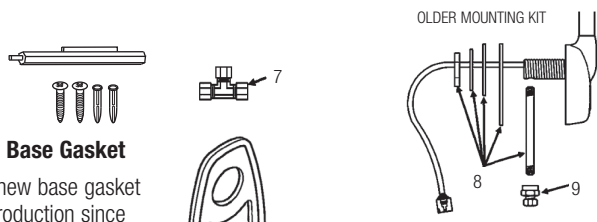

New Base Gasket

The new base gasket (in production since October 1999) is shown below. An older base gasket design did not have the u-shaped drainage hole.

The new mounting kit (in production since June 1999; Item 4 shown at left) includes parts for installation on both thin and thick surfaces, an ETF-591 male compression fitting, and an anti-rotation screw for installation on sheet metal surfaces less than 0.41" (10 mm) thick. For surfaces between 0.41" (10 mm) and 1.00" (25 mm) thick, use the mounting spacer and mounting stud hardware. The faucet sensor cable is threaded through a groove on the side of the shank.

The older mounting kits (Items 8 and 9) can be identified by a copper supply tube attached to the faucet shank, requires an ETF-547 compression fitting, and threads the faucet sensor cable through the interior of the shank.

The current parts breakdown shown above has been in production since September 2008. For earlier EBF-650/615 faucet models, please refer to the parts breakdown at right or consult your nearest Sloan representative.

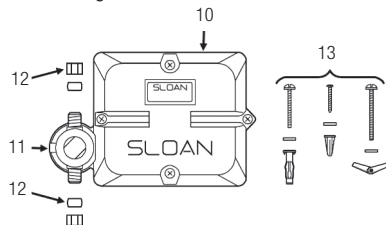

PARTS LIST—EBF-550 FAUCET

Item No.	Code No.	Part No.	Description
1A.	0315234	EBF-222-A-ST	Faucet and Sensor Assembly with Standard Gooseneck Spout (EBF-550) w/ ETF-178 (new sensor w/ phone jack)
1B.	0315227PK*	EBF-222-A-SU	Faucet and Sensor Assembly with Surgical Bend Gooseneck Spout (EBF-550-S) w/ ETF-178 (new sensor w/ phone jack)
2.	0305784	ETF-178	Adapter for Spray Heads (not required for AC-55-A Shower Spray Head)
3A.	0365147	ETF-621	2.2 gpm (8.3 Lpm) Laminar Flow Spray Head with Key (female thread)
	0365793	ETF-839	0.35 gpm (1.3 Lpm) Multi-Lam Spray Head
	0305927	ETF-435	Replacement Key ONLY
3B.	0328134	AC-55-A	Shower Spray Head Assembly, 2.2 gpm (8.3 Lpm)
4.	0315060	EBF-110-A	Faucet Mounting Kit includes Base Gasket, large Flat Washer, large Lockwasher, large Nut, Mounting Spacer, Mounting Stud, small Flat Washer, small Lockwasher, small Nut, Anti-Rotation Screw, and Compression Fitting Connector (male)
	0365152	ETF-591	1/8" NPT Pipe to 3/8" Tube Male Compression Fitting Connector
5.	0365758	ETF-740-A	6 VDC Solenoid Valve Assembly
5A.	0365774	ETF-742-A	6 VDC Solenoid Valve Only
6.	0365752	ETF-735-A	Control Module
7.	3365461	ETF-617-A	Bak-Chek® "T" Assembly
—	0365838	ETF-1003	36" Extension Cable (Optional)

— Not shown in illustration
* Obsolete/No Substitution Available

OLD MOUNTING KIT AND FAUCET SHANK

8.	N/A^{††}	EBF-110-A	Old Faucet Mounting Kit included 3/8" Water Supply Tube, Base Gasket, large Flat Washer, large Lock Washer, large Nut, and Compression Fitting Connector (order Items 4 and 10 as replacement parts)
9.	0365058^{††}	ETF-547	1/8" NPT Pipe to 3/8" Tube Female Compression Fitting Connector

Note: earlier faucet models are not compatible with the current models.

PARTS PRIOR TO SEPTEMBER 2009

10.	0315104	EBF-60-A	Control Module Assembly
11.	0315254	EBF-1011-A	Solenoid Replacement Kit
12.	3315029	EBF-113-A	Single Solenoid Supply Compression Nut Kit
13.	3315018	EBF-79-A	Mounting Hardware Kit
14.	3315222PK	EBF-222A-ST	Standard Gooseneck Spout & Old Style Sensor Assembly (Flat 7 wire Black Modular Plug)
15.	0315153	EBF-206-A	Sensor Window w/ Cable Assembly

OLD Optima® EBF-550/EBF-550-S Faucets (Prior to 8-1-2018)

TROUBLESHOOTING GUIDE

1. Sensor LED does not function (sensor indicator light DOES NOT flash during initial 10 minute set-up mode).

A. There is no visible indicator light. Normal operation. This is a normal operating feature of the faucet.

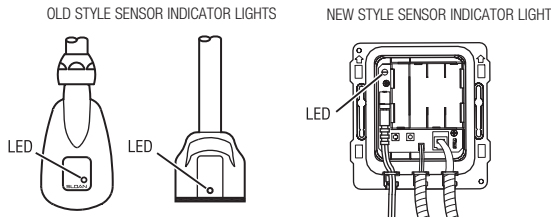

2. Faucet DOES NOT deliver any water when Sensor is activated.

INDICATOR: Solenoid valve produces audible “CLICK.”

A. Water supply stop(s) closed. Open supply stop(s) completely.

INDICATOR: Solenoid valve DOES NOT produce an audible “CLICK.”

B. Solenoid lead is not properly connected to the control module. Disconnect and reconnect solenoid lead to the control module.

C. No battery or transformer (optional) power is being supplied to sensor. Ensure that the batteries are installed properly. Check that the orientation of each battery matches the positive (+) and negative (–) symbols shown on the bottom of the battery compartment. Reinsert the batteries into the control module. Transformer (optional) is unplugged or wall receptacle has no power.

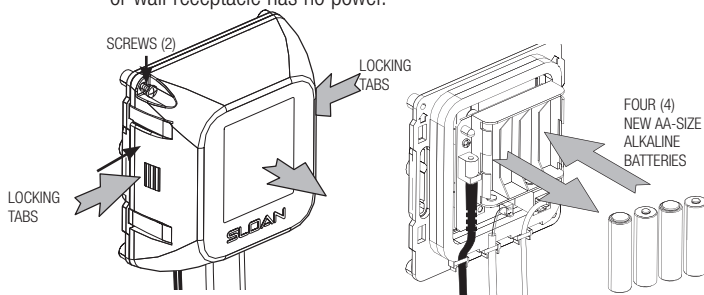

D. Sensor cable is not properly connected to the control module. Disconnect and reconnect sensor cable to the control module.

E. Sensor range is set at minimum distance. Increase sensor range. Refer to range adjustment in your installation instructions.

F. Control module assembly is not working properly. Replace control module assembly.

3. Faucet delivers only a slow flow or dribble when sensor is activated.

A. Water supply stop(s) partially closed. Open supply stop(s) completely.

B. Solenoid filter is clogged. Remove, clean and reinstall filter. Turn off water supply at supply stop(s). Activate faucet to relieve system pressure. Remove water supply line from inlet side of solenoid valve. Remove cap, water line fitting, gasket, filter housing and filter from solenoid valve housing. Slide filter off filter housing. Clean filter using fresh tap water only. If necessary, use a small brush to clean. Use caution while cleaning to prevent damage to filter. If any filter components are damaged, replace as necessary. Examine the gasket for wear or damage; replace if necessary. Reinstall filter on filter housing. Install filter housing, gasket, water line fitting and cap onto solenoid valve housing. Tighten cap securely. Reinstall water supply line to inlet side of solenoid valve.

C. Aerator is clogged. Remove, clean and reinstall aerator.

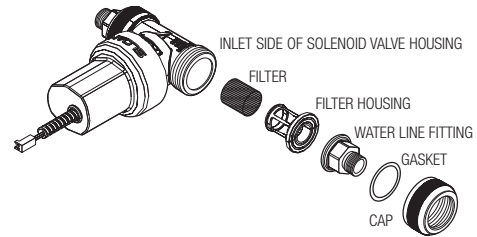

4. Faucet DOES NOT stop delivering water or continues to drip after user is no longer detected (automatic shut-off fails even when batteries are removed).

A. Solenoid valve has been connected backwards. Disconnect solenoid valve compression fittings at both the inlet and outlet positions. The water should flow from inlet through the solenoid valve to the outlet according to the direction of the arrow shown on the side of the solenoid valve. Reconnect the compression fittings in the correct orientation.

B. Solenoid valve is dirty. Backflush by reversing water flow (opposite to the direction shown by the arrow on the side of the solenoid valve) through the solenoid valve. Reconnect the compression fittings in the correct orientation. Activate faucet.

C. Solenoid valve module is not working properly. Replace solenoid valve module.

5. The water temperature is too hot or too cold on a faucet connected to hot and cold supply lines with Bak-Chek® Tee.

A. Supply stops are not adjusted properly. Adjust supply stops.

NOTE: For some systems, a thermostatic mixing valve may be required.

6. The RED LED turns on in the control module (below deck).

A. One (or more) of the batteries is “dead”. To ensure proper operation, insert four (4) new AA-size Alkaline batteries. Check that the orientation of each battery matches the positive (+) and negative (–) symbols shown on the bottom of the battery compartment. Reinsert batteries into the control module.

B: Upon start-up mode the control module circuitry also tests the batteries and the RED LED turns on if the battery voltage is low, no RED LED light indicates normal battery voltage.

C. If reset (initiates start up mode) button is pressed, the battery voltage is checked. If voltage is too low, product is stopped from operating and RED LED will turn on. No RED LED light indicates normal battery voltage.

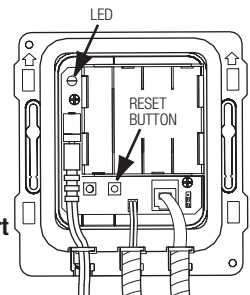

7. The GREEN LED initially turns on in the control module (below deck) during start up mode, then will not appear again.

INDICATOR: For the 1st ten minutes of operation (batteries inserted or reset button pressed) the GREEN LED will turn on when there is a target present (hands in front of sensor). After ten minutes, the GREEN LED will no longer turn on.

A. This is a normal operating feature of the faucet.

OLD Optima® ETF-500/ETF-500-S Faucets
(Prior to 8-1-2018)

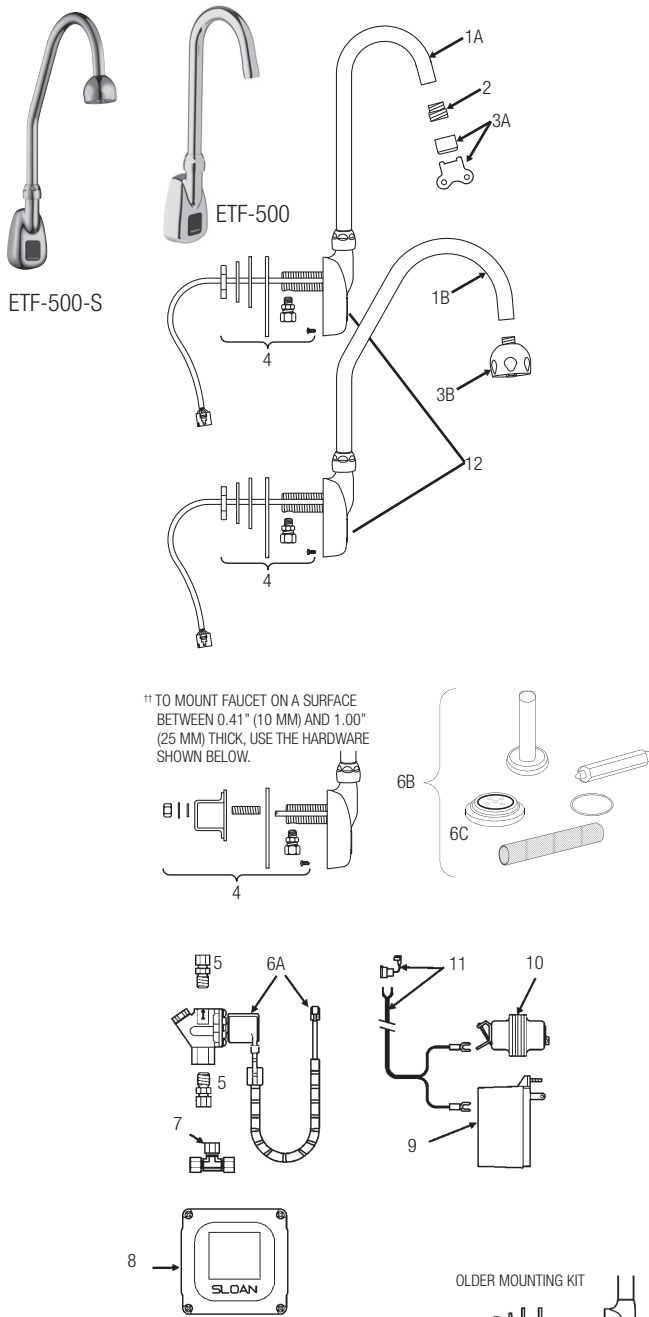

New Base Gasket
The new base gasket (in production since October 1999) is shown at right. An older base gasket design did not have the u-shaped drainage hole.

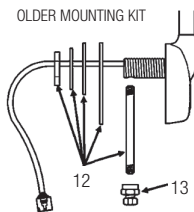

PARTS LIST—ETF-500 FAUCET

Item No.	Code No.	Part No.	Description
1A.	0365778	ETF-772-A-ST	Faucet/Sensor Assembly with Standard Gooseneck Spout
1B.	0365783	ETF-772-A-SU	Faucet/Sensor Assembly with Surgical Bend Gooseneck Spout
2.	0305784	ETF-178	Aerator Adapter for Spray Heads (not required for AC-55-A Shower Spray Head)
3A.	0365147	ETF-621-A	2.2 gpm (8.3 Lpm) Aerator Spray Head with Key (female thread)
	0365793	ETF-839	0.35 gpm (1.3 Lpm) Multi-Lam Spray Head
	0305927	ETF-435	Replacement Key ONLY
3B.	0328134	AC-55-A	Shower Spray Head Assembly, 2.2 gpm (8.3 Lpm)
4.	0315060	EBF-110-A	Faucet Mounting Kit includes Base Gasket, large Flat Washer, large Lock Washer, large Nut, Mounting Spacer, Mounting Stud, small Flat Washer, small Lock Washer, small Nut, Anti-Rotation Screw, and Compression Fitting Connector (male)
—	0365152	ETF-591	1/8" NPT Pipe to 3/8" Tube Male Compression Fitting Connector
5.	3365676	ETF-437-A	Single Solenoid Supply Kit includes, two (2) Compression Fittings, Compression Nut, and Ferrule
6A.	0305849	ETF-370-A	24 VAC Solenoid Valve Assembly includes 18" (457 mm) armored Cable and two (2) Terminal Housings
6B.	3305577	ETF-1009-A	Solenoid Valve Repair Kit includes Replacement Filter, Guide, Armature Spring, Diaphragm and Washer
6C.	3375003	MCR-1003-A	Diaphragm only
7.	3365461	ETF-617-A	Bak-Chek® "T" Assembly
8.	3365000	ETF-450-A	Control Module Assembly includes splashproof Junction Box and Junction Box Mounting Kit
9.	0365534	ETF-233	120V/35VA Plug-In Transformer
10.	0345370	EL-248-40	24V/40VA Box Mount Transformer
11.	0365001	ETF-458-A	Input Power Cable (Transformer to Control Module) includes Strain Relief and two (2) Terminal Crimp Connectors
12.	0365097	ETF-568-A	Sensor Only

See page 220 for faucet cable extension cords.

— = Not shown in illustration

OLD MOUNTING KIT AND FAUCET SHANK

12.	N/A ^{††}	EBF-110-A	Old Faucet Mounting Kit included 3/8" Water Supply Tube, Base Gasket, large Flat Washer, large Lock Washer, large Nut, and Compression Fitting Connector (order Items 4 and 13 as replacement parts)
13.	0365058 ^{††}	ETF-547	1/8" NPT Pipe to 3/8" Tube Female Compression Fitting Connector

The new mounting kit (in production since June 1999; Item 4 shown at left) includes parts for installation on both thin and thick surfaces, an ETF-591 male compression fitting, and an anti-rotation screw for installation on sheet metal surfaces less than 0.41" (10 mm) thick. For surfaces between 0.41" (10 mm) and 1.00" (25 mm) thick, use the mounting spacer and mounting stud hardware. The faucet sensor cable is threaded through a groove on the side of the shank.

The older mounting kits (Items 12 and 13) can be identified by a copper supply tube attached to the faucet shank, requires an ETF-547 compression fitting, and threads the faucet sensor cable through the interior of the shank.

OLD Optima® ETF-500/ETF-500-S Faucets (Prior to 8-1-2018)

TROUBLESHOOTING GUIDE

1. No water is delivered when faucet is activated.

INDICATOR: If no LED lights illuminate:

- A. No electricity is being supplied to faucet. Ensure that the main power is turned "ON". Check all transformer, sensor, solenoid and cable connections. Make sure that transformer is supplying 24 VAC (Volts AC). If no voltage is detected, replace transformer.
- B. There is an electrical system malfunction. Reset electrical system. Unplug sensor connection. Disconnect power to circuit for ten (10) seconds. Reconnect.

INDICATOR: If the GREEN LED illuminates when power is reconnected:

- C. There is a short in the Sensor. Replace sensor. Refer to individual faucet parts diagram for appropriate sensor assembly. **NOTE:** GREEN LED may illuminate immediately after sensor disconnection.
- D. There is a short in the solenoid or solenoid cable. Replace ETF-370-A solenoid.

INDICATOR: If the GREEN LED does NOT illuminate when power is reconnected:

- E. There is an electrical system malfunction. Reset electrical system. Unplug sensor connection. Disconnect power to circuit for ten (10) seconds. Reconnect.
- F. The control module circuit is not working properly. Replace ETF-450-A control module.

INDICATOR: If GREEN LED illuminates AND changes to RED when hands are in the sensor's detection zone AND the RED solenoid LED illuminates:

- G. Water supply stop(s) may be partially closed. Open stop(s) if closed.
- H. Debris is clogging solenoid filter. Shut off water supply. Remove, clean and reinstall solenoid filter.

INDICATOR: If GREEN LED illuminates AND changes to RED when hands are placed in the sensor's detection zone AND the RED solenoid LED flickers with a vibrating/clicking noise heard inside the module: **NOTE:** Applies only to REVISION 2 MODULES.

- I. There is a direct short in the solenoid or solenoid cable. Replace with ETF-370-A solenoid.

INDICATOR: If GREEN/RED LED illuminates AND changes to RED when hands are NOT located in the sensor's detection zone BUT the RED solenoid LED (in upper left corner of circuit) does NOT illuminate:

- J. Sensor range is set too long and is detecting the sink. Reduce sensor detection range.
- K. Sensor is not working properly. Replace sensor. Refer to individual faucet parts diagram for appropriate sensor assembly.

INDICATOR: If GREEN LED illuminates BUT does NOT change to red when hands are placed in the sensor's detection zone:

- L. Sensor range is set too short. Increase sensor detection range.
- M. Sensor is not working properly. Replace sensor. Refer to individual faucet parts diagram for appropriate sensor assembly.

2. Sensing range is too short.

- A. Extended range sensitivity is required. Dip switch number 4 should be in the "DOWN" (Extended range sensitivity) position. Increase range by

adjusting range potentiometer clockwise (yellow phillips screw in blue base).

- B. Faucet has surgical bend gooseneck spout. For long range use (recommended for surgical bend gooseneck spout faucet models), remove range jumper from upper right hand corner of circuit board. Adjust range potentiometer. **NOTE:** Applies only to REVISION 2 MODULES.

3. Faucet activates by itself (false triggers).

- A. Sensor range is set too long. Decrease range by adjusting range potentiometer counterclockwise. If necessary, flip dip switch number 4 into the "UP" (reduced range sensitivity) position. Check surroundings for factors that contribute to sensor range detection problems (bright lights, highly reflective surfaces, sunlight, etc.).

4. Faucet delivers very low flow or just a dribble.

- A. Water supply stop(s) may be partially closed. Open stop(s).
- B. Debris is clogging solenoid filter. Shut off water. Remove, clean, and reinstall solenoid filter.
- C. Solenoid is worn or not working properly. Rebuild with ETF-1009-A solenoid repair kit or replace ETF-370-A solenoid.
- D. Debris is clogging faucet aerator or spray head. Shut off water. Use key if required to remove. Then clean and reinstall aerator or spray head.

5. Faucet DOES NOT stop delivering water or continues to drip after user is no longer detected (even after power to the module has been disconnected).

- A. Solenoid valve is installed backward. Disconnect solenoid. Reconnect solenoid with water flow towards the faucet (see arrow on solenoid).
- B. Debris is clogging solenoid. Remove and clean solenoid operator. If necessary, rebuild with ETF-1009-A repair kit.
- C. Seat in solenoid valve body is damaged or pitted. Replace with ETF-370-A solenoid.

**When assistance is required, please contact
Sloan Technical Support at: 1-888-SLOAN-14 (1-888-756-2614).**

OLD Optima® ETF-660/ETF-770 Faucets
(Prior to 8-1-2018)



Old-Style Faucets ETF-66 and ETF-77 faucets manufactured before 1996 used an EL-350-A microphone-style sensor with telephone jack connector and an ETF-214-A control module.

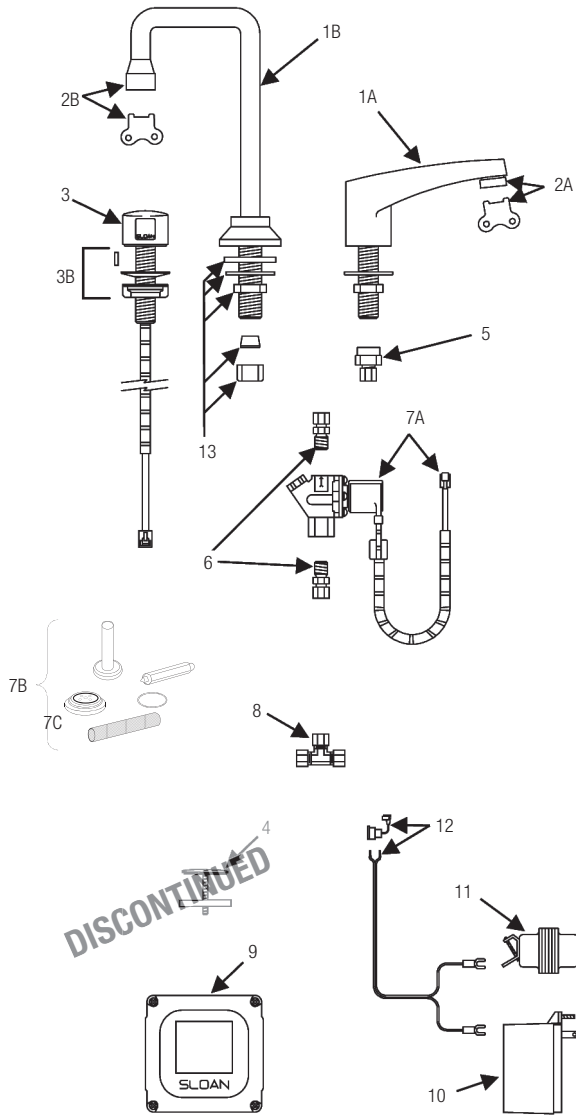

Optional Trim Plates

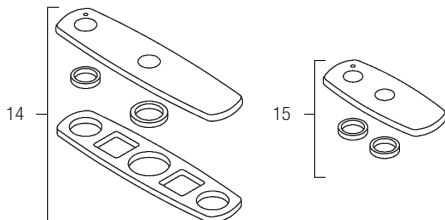

PARTS LIST—ETF-660 AND ETF-770 FAUCETS

Item No.	Code No.	Part No.	Description
1A.	0365162	ETF-595-A	Lavatory Faucet Assembly (ETF-660)
1B.	0305536	ETF-261-A	Deck-Mounted Gooseneck Faucet Assembly (ETF-770)
2A.	3365092	ETF-1023-A	0.5 gpm (1.9 Lpm) Spray Head with Key (male thread)
	3365093	ETF-1024-A	2.2 gpm (8.3 Lpm) Aerator Spray Head with Key (male thread)
	3365162	ETF-1029-A	2.2 gpm (8.3 Lpm) Laminar Flow Spray Head with Key (male thread)
	0335927	ETF-435	Replacement Key Only for ETF-1023-A Spray Head and ETF-1024-A Aerator Spray Head (NOT required for F-175-L Laminar Flow Spray Head)
	3365756	ETF-1039-A	0.35 gpm (1.3 Lpm) Multi-Lam Spray Head VR
2B.	3365091	ETF-1021-A	0.5 gpm (1.9 Lpm) Spray Head with Key (female thread)
	3365090	ETF-1022-A	2.2 gpm (8.3 Lpm) Aerator Spray Head with Key (female thread)
	3365160	ETF-1027-A	2.2 gpm (8.3 Lpm) Laminar Flow Spray Head with Key (female thread)
	0305927	ETF-435	Replacement Key Only
	3365755	ETF-1038-A	0.35 gpm (1.3 Lpm) Multi-Lam Spray Head VR
3.	0305946	EL-3500-A	Microphone-style "On-Q" Sensor Assembly includes O-ring, 18" armored Cable, Microphone Sensor Cap, Locking Pin, Microphone Sensor Body, and Emitter/Detector Shroud
3B.	0305528	EL-289	Microphone Mounting Kit
4.	0365524	ETF-199	Cock Hole Cover — DISCONTINUED
5.	0305513	ETF-271	3/8" Tube Fitting Connector (female)
6.	3365676	ETF-437-A	Single Solenoid Supply Kit includes, two (2) Compression Fittings, Compression Nut, and Ferrule
7A.	0305849	ETF-370-A	24 VAC Solenoid Valve Assembly includes 18" (457 mm) armored Cable and two (2) Terminal Housings
7B.	3305577	ETF-1009-A	Solenoid Valve Repair Kit includes Replacement Filter, Guide, Armature Spring, Diaphragm and Washer
7C.	3375003	MCR-1003-A	Diaphragm only
8.	3365461	ETF-617-A	Bak-Chek® "T" Assembly
9.	3365000	ETF-450-A	Control Module Assembly includes splashproof Junction Box and Junction Box Mounting Kit
10.	0365534	ETF-233	120V/35 VA Plug-In Transformer
11.	0345370	EL-248-40	24V/40 VA Box Mount Transformer
12.	0365001	ETF-458-A	Input Power Cable (Transformer to Control Module) includes Strain Relief and two (2) Terminal Crimp Connectors
13.	0305768	EL-310-A	Spout Mounting Kit (ETF-770 Only) Includes Rubber Washer, Steel Washer, Lock Nut, Rubber Cone Washer, and Coupling Nut
14.	3365602	ETF-432-A	Optional 8" (203 mm) Centerset Trim Plate Kit, includes Seal, Washer Fender, Gasket, Finger Nut, Trim Plate Spacer and Dual Hole Trim Plate Assembly
15.	3365469	ETF-313-A	Optional 4" (102 mm) Centerset Trim Plate Kit includes Trim Plate Spacer and Dual Hole Trim Plate Assembly

— = Not shown in illustration

NOTE: For older style ETF-66/77 faucets the replacement EL-350 is discontinued. Replacement is ETF-1019-A includes EL-3500-A and ETF-450-A.

NOTE: For the replacement control module when the older style 3 phone jack module is used, use ETF-492-A.

OLD Optima® ETF-660/ETF-770 Faucets (Prior to 8-1-2018)

TROUBLESHOOTING GUIDE

1. No water is delivered when faucet is activated.

INDICATOR: If no LED lights illuminate:

- A. No electricity is being supplied to faucet. Ensure that the main power is turned "ON". Check all transformer, sensor, solenoid and cable connections. Make sure that transformer is supplying 24 VAC (Volts AC). If no voltage is detected, replace transformer.
- B. There is an electrical system malfunction. Reset electrical system. Unplug sensor connection. Disconnect power to circuit for ten (10) seconds. Reconnect.

INDICATOR: If the GREEN LED illuminates when power is reconnected:

- C. There is a short in the sensor. Replace sensor. Refer to individual faucet parts diagram for appropriate sensor assembly. **NOTE:** GREEN LED may illuminate immediately after sensor disconnection.
- D. There is a short in the solenoid or solenoid cable. Replace ETF-370-A solenoid.

INDICATOR: If the GREEN LED does NOT illuminate when power is reconnected:

- E. There is an electrical system malfunction. Reset electrical system. Unplug sensor connection. Disconnect power to circuit for ten (10) seconds. Reconnect.
- F. The control module circuit is not working properly. Replace ETF-450-A control module.

INDICATOR: If GREEN LED illuminates AND changes to RED when hands are in the sensor's detection zone AND the RED solenoid LED illuminates:

- G. Water supply stop(s) may be partially closed. Open stop(s) if closed.
- H. Debris is clogging solenoid filter. Shut off water supply. Remove, clean and reinstall solenoid filter.

INDICATOR: If GREEN LED illuminates AND changes to RED when hands are placed in the sensor's detection zone AND the RED solenoid LED flickers with a vibrating/clicking noise heard inside the module: Note: Applies only to REVISION 2 MODULES.

- I. There is a direct short in the solenoid or solenoid cable. Replace with ETF-370-A solenoid.

INDICATOR: If GREEN/RED LED illuminates AND changes to RED when hands are NOT located in the sensor's detection zone BUT the RED solenoid LED (in upper left corner of circuit) DOES NOT illuminate:

- J. Sensor range is set too long and is detecting the sink. Reduce sensor detection range.
- K. Sensor is not working properly. Replace sensor. Refer to individual faucet parts diagram for appropriate sensor assembly.

INDICATOR: If GREEN LED illuminates BUT DOES NOT change to red when hands are placed in the sensor's detection zone:

- L. Sensor range is set too short. Increase sensor detection range.
- M. Sensor is not working properly. Replace sensor. Refer to individual faucet parts diagram for appropriate sensor assembly.

2. Sensing range is too short.

- A. Extended range sensitivity is required. Dip switch number 4 should be in the "DOWN" (Extended range sensitivity) position. Increase range by adjusting range potentiometer clockwise (yellow phillips screw in blue base).
- B. Faucet has surgical bend gooseneck spout. For long range use (recommended for surgical bend gooseneck spout faucet models), remove range jumper from upper right hand corner of circuit board. Adjust range potentiometer. Note: Applies only to REVISION 2 MODULES.

3. Faucet activates by itself (false triggers).

- A. Sensor range is set too long. Decrease range by adjusting range potentiometer counterclockwise. If necessary, flip dip switch number 4 into the "UP" (reduced range sensitivity) position. Check surroundings for factors that contribute to sensor range detection problems (bright lights, highly reflective surfaces, sunlight, etc.).

4. Faucet delivers very low flow or just a dribble.

- A. Water supply stop(s) may be partially closed. Open stop(s).
- B. Debris is clogging solenoid filter. Shut off water. Remove, clean, and reinstall solenoid filter.
- C. Solenoid is worn or not working properly. Rebuild with ETF-1009-A solenoid repair kit or replace ETF-370-A solenoid.
- D. Debris is clogging faucet aerator or spray head. Shut off water. Use key if required to remove. Then clean and reinstall aerator or spray head.

5. Faucet DOES NOT stop delivering water or continues to drip after user is no longer detected (even after power to the module has been disconnected).

- A. Solenoid valve is installed backward. Disconnect solenoid. Reconnect solenoid with water flow towards the faucet (see arrow on solenoid).
- B. Debris is clogging solenoid. Remove and clean solenoid operator. If necessary, rebuild with ETF-1009-A repair kit.
- C. Seat in solenoid valve body is damaged or pitted. Replace with ETF-370-A solenoid.

**When assistance is required, please contact
Sloan Technical Support at: 1-888-SLOAN-14 (1-888-756-2614).**

OLD **Optima® ETF-800 Faucet**
(Prior to 8-1-2018)

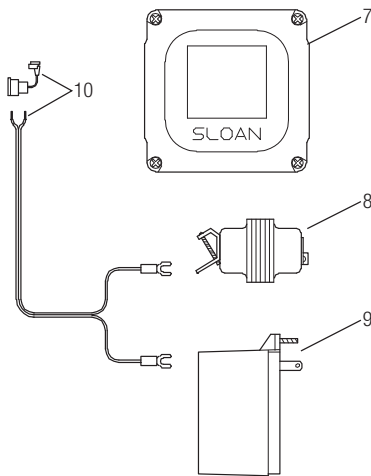
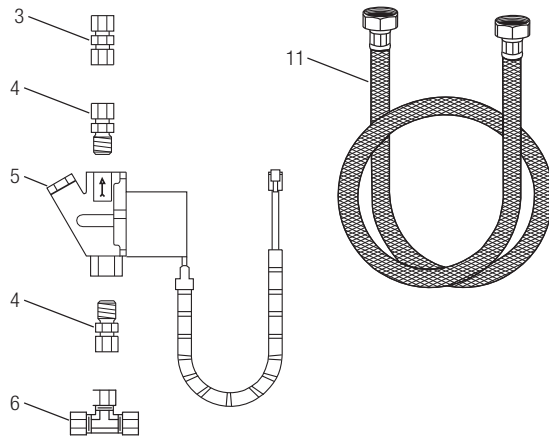
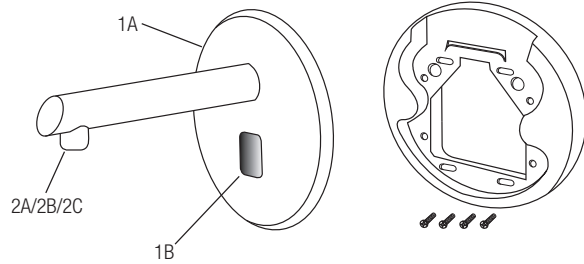

PARTS LIST—ETF-800 FAUCET

Item No.	Code No.	Part No.	Description
1A.	0365797	ETF-797-A	Faucet Spout and Sensor Assembly
1B.	0365097	ETF-568-A	Sensor Assembly only
2A.	0365378	ETF-687	1.5 gpm/5.7 Lpm Laminar Flow Spray Head
2B.	3365757	ETF-1040-A	0.35 gpm/1.3 Lpm Multi-Lam Spray Head
2C.	0365147	ETF-621	2.2 laminar Flow Spray Head
3.†	0365057	ETF-530	Compression Fitting
4.†	0305459	ETF-61	Compression Fittings (2)
5.	0305849PK	ETF-370-A	24 VAC Solenoid Valve Assembly; Includes Wire Harness
—	3305577	ETF-1009-A	Solenoid Valve Repair Kit, Includes Replacement Filter
6.	3365461	ETF-617-A	3/8" Bak-Chek® Tee Compression Fitting
7.	3365000	ETF-450-A	Control Module Assembly
8.	0345370	EL-248-40	Box Mount Transformer
9.	0365534	ETF-233	Plug-In Transformer
10.	0365001	ETF-458-A	Power Cable with Strain Relief and Crimp Connectors (Transformer to Control Module)
11.	3326091	MIX-19	Flex Hose

† ETF-798-A Compression Fitting Kit, includes (1) ETF-530, (2) ETF-61 Compression Fittings and (4) Mounting Plate Screws

OLD Optima® ETF-800 Faucet (Prior to 8-1-2018)

RANGE ADJUSTMENT

The Optima ETF-800 faucet is factory set to activate when hands are placed 4 to 5 inches (102 to 127 mm) from sensor. This range should be satisfactory for most installations.

If range adjustment is required, refer to the following range adjustment procedures.

TO MAKE A RANGE ADJUSTMENT

The range potentiometer and dip Switches are located in control module.

IMPORTANT: Range Potentiometer adjustment screw rotates only 3/4 of a turn; **DO NOT** over-rotate.

Make certain that dip switch number 4 is in the DOWN position. Using the small screwdriver provided, adjust range potentiometer clockwise until green (power ON) indicator LED turns red (Faucet is now picking up sink). Adjust range potentiometer back counterclockwise until red LED returns to green. Range is now at maximum.

In the event the LED remains red with the adjustment at minimum (counterclockwise) setting, the sensitivity can be further reduced by switching Dip Switch number 4 to the ON (UP) position.

Cycle faucet several times to assure that range as adjusted will not inadvertently pick up IR reflection in lavatory. If IR reflection occurs (green LED will flicker red), adjust range potentiometer counterclockwise very slightly and again cycle faucet.

Repeat range adjustment counterclockwise until length of range is at bowl rim of lavatory (plus or minus 1 inch (25 mm)).

TIME OUT ADJUSTMENT

The Faucet Time Out Setting determines the maximum time the faucet will run upon continuous activation. This timing can be changed to meet individual application requirements.

Refer to Table 1 or label on cover of control module along with the following instructions to set the desired time out. The dip switches used to set the time out are located in the control module.

Set the Time Out by configuring the number 1, 2 and 3 Dip Switches as shown in Table 1.

Table 1 — Time Out Settings

Time Out	Dip Switch Setting		
	Switch #1	Switch #2	Switch #3
3 SECONDS	UP	UP	DOWN
6 SECONDS	DOWN	DOWN	UP
12 SECONDS	UP	DOWN	UP
30 SECONDS	UP	DOWN	DOWN
45 SECONDS	UP	UP	UP
1 MINUTES	DOWN	UP	UP
3 MINUTES	DOWN	DOWN	DOWN
20 MINUTES	DOWN	UP	DOWN

Unless otherwise specified, all ETF-800 faucets leave the factory set with a 30 second Time Out.

NOTE: The position of Dip Switch #4 (range enhancer setting) does not affect Faucet Time Outs.

Push Cables into slots at the bottom of the control module.

Install control module cover using screws provided.

TEST FAUCET OPERATION

1. A continuous invisible beam of light is emitted from the Optima sensor located below the faucet spout.

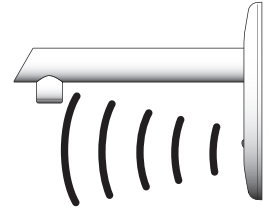

2. As the user's hands enter the beam's effective range, the beam is reflected back into the sensor receiver and activates the solenoid valve allowing tempered water to flow from the faucet. Water will flow until the hands are removed or until the faucet reaches its automatic time out limit setting.

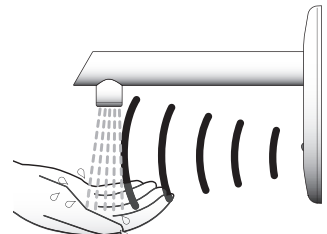

3. When hands are moved away from the Optima sensor, the loss of reflected light initiates an electrical signal that deactivates the solenoid valve shutting off the water flow. The circuit then automatically resets and is ready for the next user.

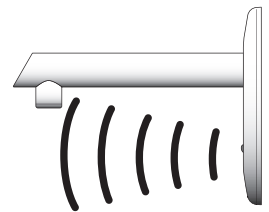

OLD Optima® ETF-800 Faucet (Prior to 8-1-2018)

TROUBLESHOOTING GUIDE

NOTE: Remove cover from control module to check diagnostic lights.

1. No water is delivered when faucet is activated.

INDICATOR: If no LED lights illuminate:

- A. No electricity is being supplied to faucet. Ensure that the main power is turned "ON." Check all transformer, sensor, solenoid and cable connections. Make sure that transformer is supplying 24 VAC (Volts AC). If no voltage is detected, replace transformer.
- B. There is an electrical system malfunction. Reset electrical system. Unplug sensor connection. Disconnect power to circuit for ten (10) seconds. Reconnect.

INDICATOR: If the GREEN LED illuminates when power is reconnected:

- C. There is a short in the sensor. Replace sensor.

Note: GREEN LED may illuminate immediately after sensor disconnection.

- D. There is a short in the solenoid or solenoid cable. Replace ETF-370-A solenoid.

INDICATOR: If the GREEN LED does NOT illuminate when power is reconnected:

- E. There is an electrical system malfunction. Reset electrical system. Unplug sensor connection. Disconnect power to circuit for ten (10) seconds. Reconnect.
- F. The control module circuit is not working properly. Replace ETF-450-A control module.

INDICATOR: If GREEN LED illuminates AND changes to RED when hands are in the sensor's detection zone AND the RED solenoid LED illuminates:

- G. Water supply stop(s) may be partially closed. Open supply stop(s) completely.
- H. Debris is clogging solenoid filter. Shut off water supply. Remove, clean and reinstall solenoid filter.

INDICATOR: If GREEN LED illuminates AND changes to RED when hands are placed in the sensor's detection zone AND the RED solenoid LED flickers with a vibrating/clicking noise heard inside the module:

- I. There is a direct short in the solenoid or solenoid cable. Replace with ETF-370-A solenoid.

INDICATOR: If GREEN/RED LED illuminates AND changes to RED when hands are NOT located in the sensor's detection zone BUT the RED solenoid LED (in upper left corner of circuit) does NOT illuminate:

- J. Sensor range is set too long and is detecting the sink. Reduce sensor detection range.
- K. Sensor is not working properly. Replace sensor.
- INDICATOR: If GREEN LED illuminates BUT DOES NOT change to RED when hands are placed in the sensor's detection zone:
- L. Sensor range is set too short. Increase sensor detection range.
- M. Sensor is not working properly. Replace sensor.

2. Sensing range is too short.

- A. Extended Range Sensitivity is required. Dip Switch number 4 should be in the "DOWN" (Extended Range Sensitivity) position. Increase range by adjusting Range Potentiometer clockwise (yellow phillips screw in blue base).

3. Faucet activates by itself (false triggers).

- A. Sensor range is set too long. Decrease range by adjusting range potentiometer counterclockwise. If necessary, flip dip switch number 4 to the "UP" (reduced range sensitivity) position. Check surroundings for factors that contribute to Sensor range detection problems (bright lights, highly reflective surfaces, sunlight, etc.).

4. Faucet delivers very low flow or just a dribble.

- A. Water supply stop(s) may be partially closed. Open supply stop(s) completely.
- B. Debris is clogging solenoid filter. Shut off water. Remove, clean, and reinstall solenoid filter or replace solenoid filter ETF-1009-A.
- C. Solenoid is worn or not working properly. Rebuild with ETF-1009-A solenoid repair kit or replace ETF-370-A solenoid.
- D. Debris is clogging faucet aerator or spray head. Shut off water. Remove aerator or spray head (use Key if required). Clean and reinstall aerator or spray head.

5. Faucet DOES NOT stop delivering water or continues to drip after user is no longer detected (even after power to the module has been disconnected).

- A. Solenoid valve is installed backward. Disconnect solenoid. Reconnect solenoid with water flow toward the faucet (see arrow on solenoid).
- B. Debris is clogging solenoid. Remove and clean solenoid operator. If necessary, rebuild with ETF-1009-A repair kit.
- C. Seat in solenoid valve body is damaged or pitted. Replace with ETF-370-A solenoid.

CARE AND CLEANING

DO NOT USE abrasive or chemical cleaners (including chlorine bleach) to clean faucets that may dull the luster and attack the chrome or special decorative finishes. Use **ONLY** mild soap and water, then wipe dry with clean cloth or towel.

While cleaning the bathroom tile, protect the faucet from any splattering of cleaner. Acids and cleaning fluids will discolor or remove chrome plating.

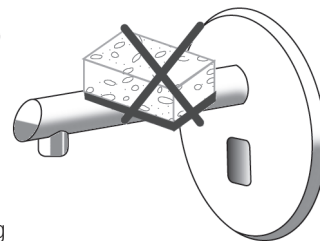

**When assistance is required, please contact
Sloan Technical Support at: 1-888-SLOAN-14 (1-888-756-2614).**

Optima® EAF-275 Faucet



EAF-275

EAF-275 Series Faucet date code 1101 and newer. Product revised to make spray head vandal resistant without need for special spray. EAF-15 only works on product date code 1052 and older.

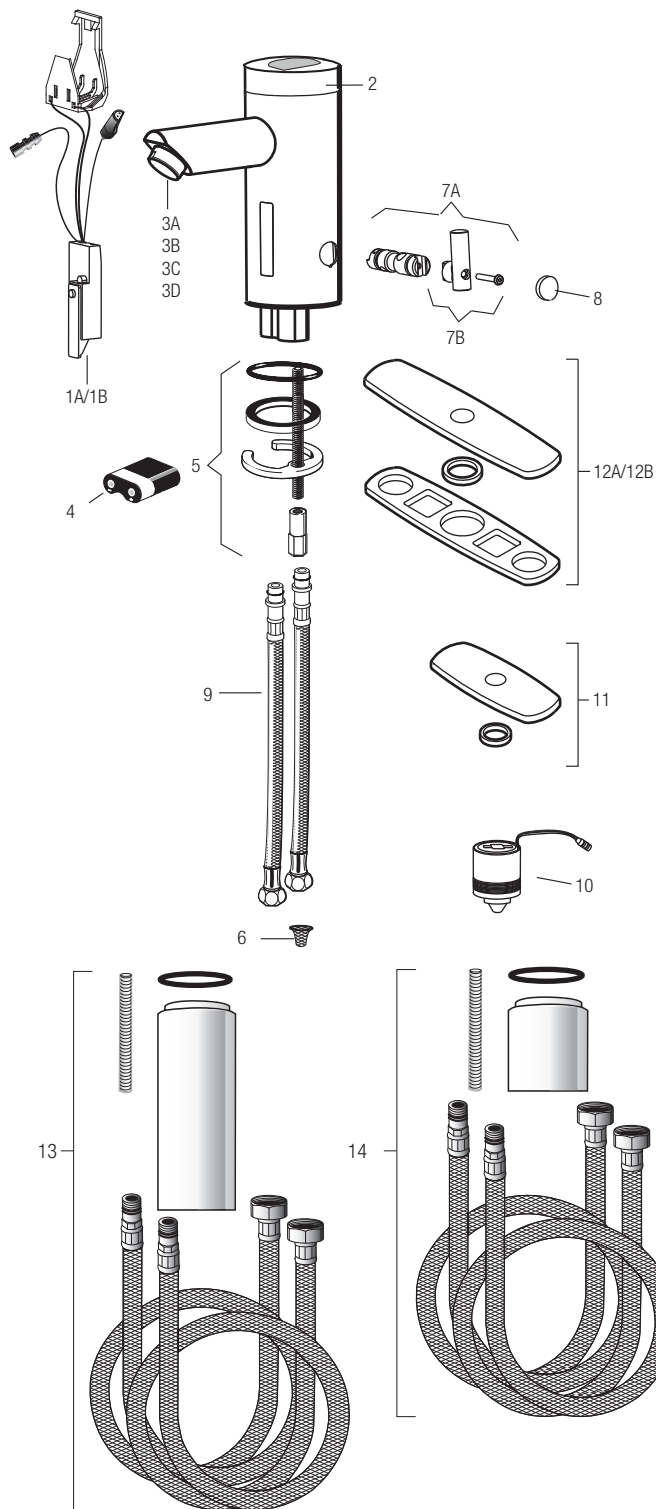

PARTS LIST—EAF-275 FAUCET

Item No.	Code No.	Part No.	Description
1A.	0335013	EAF-14-A	Faucet Sensor Assembly without i.q.-cliq
1B.	0335014	EAF-16-A	Faucet Sensor Assembly with i.q.-cliq
2.	3335021	EAF-1006	Cap and Solar Cell Assembly
3A.	0335012	EAF-15	0.5 gpm (1.9 Lpm) VR Aerator Spray Head – Pre 03/2011
3B.	0335008	EAF-10	2.2 gpm (8.3 Lpm) Aerator Spray Head
3C.	0335011	EAF-13	2.2 gpm (8.3 Lpm) Laminar Flow Spray Head
3D.	0335029	EAF-51	0.35 gpm (1.3 Lpm) Multi-Laminar Spray Head
4.	3335018	EAF-1003-A	Battery Replacement Kit (CR-P2)
5.	0335000	EAF-1	Faucet Mounting Kit
6.	0335007	EAF-9	Strainer (Filter)
7A.	3335019	EAF-1004	Mixer Handle Assembly and Cartridge
7B.	3335020	EAF-1005	Handle Repair Kit
8.	3335022	EAF-1007	Handle Cap
9.	3335023	EAF-1008	13" (330 mm) Flexible Supply Hose (1)
10.	0335001	EAF-2	Solenoid Solenoid (6 mm hex recess)
11.	3365468	ETF-312-A	Trim Plate for 4" Center-set Sink
12A.	3365024	ETF-510-A	Trim Plate for 8" Center-set Sink
12B.	3362022	SFP-22-A	Use when needing 8" for EAF-35-A extension
13.	3335035	EAF-35-A	6 3/4" Faucet Extension Kit
14.	3335046	EAF-40-A	2 1/8" Faucet Extension Kit. Raises faucet such that outlet height complies with California Office of Statewide Health Planning and Development

Optima® EAF-275 Faucet

BACK-UP BATTERY REPLACEMENT

Replace battery when red LED indicator flashes each time faucet is in use or when faucet stops functioning.

Step 1

Close supply stop(s).

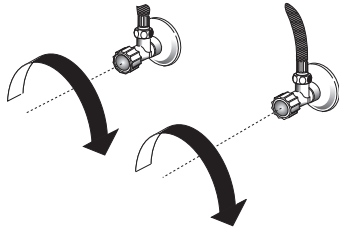

Step 2

Loosen screw with hex wrench.
Remove cap.

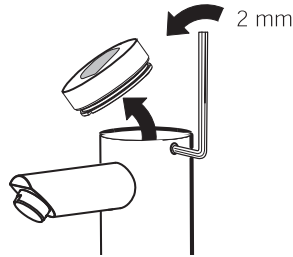

Step 3

Move battery retainer tab away from battery.
Remove old battery.
Dispose of properly.

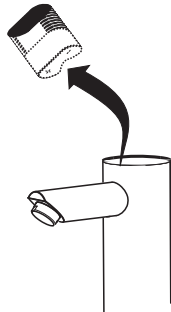

Step 4

Wait three (3) minutes
inserting new battery.



Step 5

Insert a new 6 Volt Type CR-P2 lithium
battery. The red LED will flash for
one (1) minute.

Reinstall battery cover.

If LED doesn't flash or if it just lights
up, remove the Battery. Wait three
(3) minutes, then reinsert the Battery.

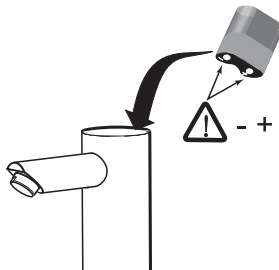

Step 6

Open supply stops.

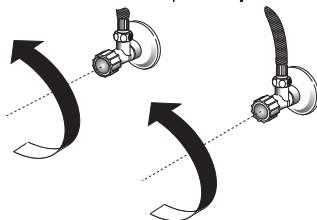

If water flows continuously after inserting the new battery and opening the supply stops, remove the battery. Wait three (3) minutes, then reinsert the battery.

**When assistance is required, please contact
Sloan Technical Support at: 1-888-SLOAN-14 (1-888-756-2614).**

TROUBLESHOOTING GUIDE

1. Faucet DOES NOT function.

- Adhesive packaging label affixed over sensor eye. Remove adhesive label from sensor eye.
- "Permanent Off" activated. Press button on faucet throat one time.

2. Faucet delivers water in an uncontrolled manner.

- Faucet is not working properly. Contact Sloan Technical Support.

3. Faucet DOES NOT deliver any water when sensor is activated.

INDICATOR: Solenoid valve produces an audible "CLICK."

- Water supply stop(s) closed. Open water supply stop(s).
- Water supply stop strainer(s) clogged. Clean water supply stop strainer(s).

INDICATOR: Solenoid valve DOES NOT produce an audible "CLICK."

- Battery low. Replace battery (refer to Battery Replacement).

4. Faucet delivers only a slow flow or dribble when sensor is activated.

- Water supply stop(s) are partially closed. Completely open water supply stop(s).
- Water supply stop strainer(s) clogged. Remove, clean, and reinstall water supply stop strainer(s). Replace strainer(s) if required.
- Aerator is clogged. Remove, clean, and reinstall aerator. Replace aerator if required.
- Faucet is not working properly. Contact Sloan Technical Support.

5. Faucet DOES NOT stop delivering water or continues to drip after user is no longer detected.

- Solenoid Valve is not working properly. Contact Sloan Technical Support.

6. LED indicator blinks when faucet is in use.

- Battery low. Replace battery (refer to battery replacement).

7. The water temperature is too hot or too cold on a faucet connected to hot and cold supply lines.

- Supply stops are not adjusted properly. Adjust supply stops.
- For models with integral mixing valve – mixing valve is set improperly for the water temperature desired. Rotate mixing valve handle clockwise to decrease water temperature or counterclockwise to increase water temperature.

CARE AND CLEANING

DO NOT USE abrasive or chemical cleaners (including chlorine bleach) to clean faucets that may dull the luster and attack the chrome or special decorative finishes. Use **ONLY** mild soap and water, then wipe dry with clean cloth or towel.

While cleaning the bathroom tile, protect the faucet from any splattering of cleaner. Acids and cleaning fluids will discolor or remove chrome plating.

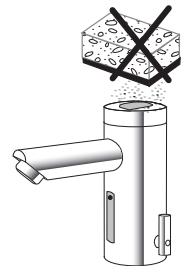

Optima® EAF-900 Faucet DISCONTINUED

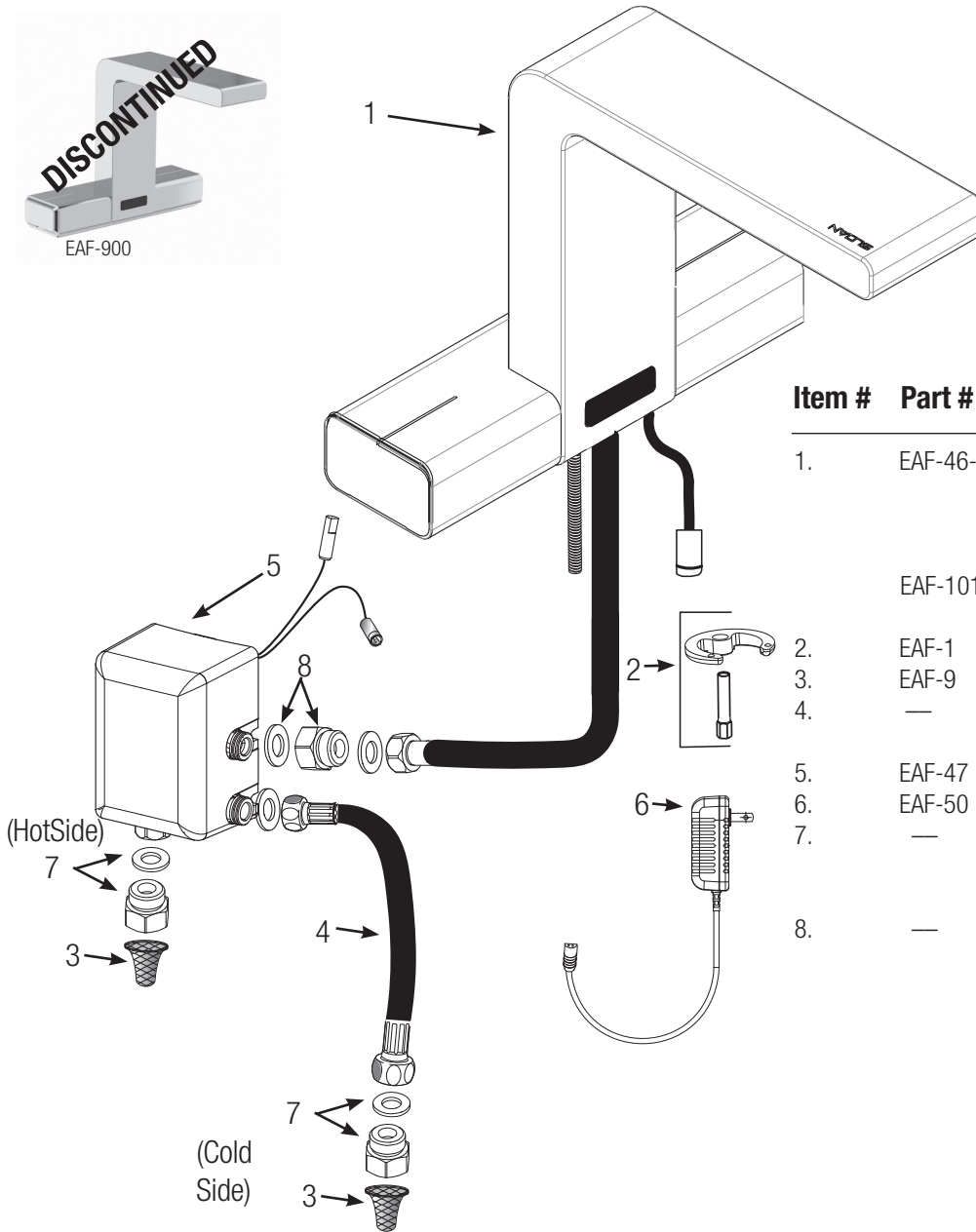

Item #	Part #	Description
1.	EAF-46-A	Spout assembly (includes 0.5 gpm Spray Head, Sensor assembly, Warm and Cold Temperature Adjustments, Hose, Strainer)
	EAF-1010	0.5gpm (1.9 Lpm) Spray Head (not shown)
2.	EAF-1	Faucet Mounting Kit
3.	EAF-9	Strainer (Filter)
4.	—	13" (330 mm) Flexible Supply Hose 3/8 NPSM X 3/8 NPSM (G3/8XG3/8)
5.	EAF-47	Control Module
6.	EAF-50	Transformer 100-240 VAC/12 VDC-1A
7.	—	Supply Fittings and Gaskets (3/8 compression female x 3/8 NPSM-G3/8)
8.	—	0.5 gpm Flow Restrictor Fitting & Gasket

Optima® EAF-900 Faucet DISCONTINUED

1. Faucet does not function properly.

- A. pause mode is activated.
End pause mode.
- B. Water Supply stop(s) closed.
open water supply stop(s).
- C. Filter is clogged.
Clean the filter.

2. Faucet does not stop delivering water or continues to run after user is no longer detected.

- A. Reflection.
Set the sensor range or activate automatic sensor adjustment.

3. The water temperature is too hot or too cold on a faucet connected to hot and cold water supply lines.

- A. Supply stops are not adjusted properly.
Adjust supply stops.

4. Faucet delivers water continuously.

- Contact Sloan Technical Support.

5. leak at fittings.

- A. Ensure gaskets are installed between fittings for 3/8" compression to g3/8".
- B. Tighten fittings.

When assistance is required, please contact
Sloan Technical Support at:

1-888-SLOAN-14 (1-888-756-2614)

Optima® EAF-150 Faucet

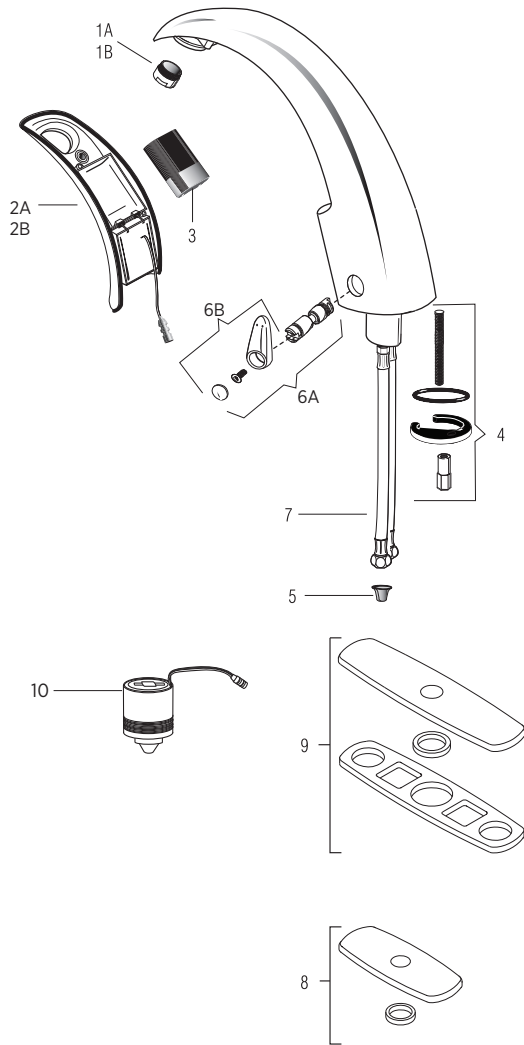

PARTS LIST—EAF-150 FAUCETS

Item			
No.	Code No.	Part No.	Description
1A.	0335008	EAF-10	2.2 gpm (8.3 Lpm) Aerator Spray Head
1B.	0335010	EAF-12	0.5 gpm (1.9 Lpm) Spray Head (Multi-Lam)
1C.	0335029	EAF-51	0.35 gpm (1.3 Lpm) Spray Head (Multi-Lam)
1D.	0335021	EAF-22	1.5 gpm (5.6 Lpm) Aerator Spray Head
2A.	0335002	EAF-3-A	Throat Plate Assembly (Battery Models) (from Nov 2018)
2B.	0335003	EAF-4-A	Sensor standard throat plate assembly with i.q. click (IC variation)
3.	3335009	EAF-1000	Battery Replacement Kit (6V 2CR5 with 2.5 mm allen Wrench)
4.	0335000	EAF-1	Faucet Mounting Kit
5.	0335007	EAF-9	Strainer (Filter) 2 required for ISM Models (one per package)
6A.	3335118	EAF-1022	Mixer Handle Assembly and Cartridge (post 2004)
6B.	3335011	EAF-1002	Handle Repair Kit
7.	3335023	EAF-1008	15" (330 mm) Flexible Supply Hose (1) with inlet filter
8.	0362011	SFP-11	Trim Plate for 4" Center-set Sink
9A.	3365303	ETF-608-A	Trim Plate for 8" Center-set Sink
9B.	3362022	SFP22A	Trim Plate for 8" Centerset sink
10.	0335001	EAF-2	Solenoid (6 mm hex recess)

EAF-1001 Mixer Handle Assembly & Cartridge Discontinued (Faucets manufactured prior 2004).
Use Mixer Handle Assembly Cartridge kit EAF-1022-A (Faucets manufactured post 2004).

Optima® EAF-150 Faucet

AUTO SENSOR CALIBRATION OR RANGE ADJUSTMENT

For sensor recalibration, press and release iq button 2 quick times, wait for rapid "temporary off" red LED flashes, then press and hold iq button for several seconds and after four (4) slow red LED flashes, release button and step away for fifteen (15) seconds to allow faucet sensor to recalibrate.

After water turns on then off and red LED flashes are followed by a single green flash (calibration complete), test faucet.

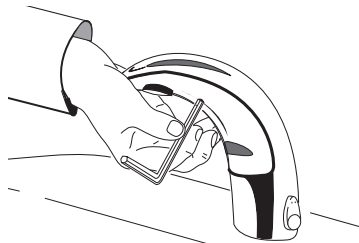

STANDARD MODELS

MANUAL RANGE ADJUSTMENT

To manually change range, press and release iq button 2 quick times, wait for rapid "temporary off" red LED flashes, then press and hold iq button, there will be four (4) red LED flashes, a pause, then more red LED flashes (up to eight (8) red LED flashes); 1-red LED flash for the shortest range setting, eight (8) flashes for the longest range setting;

Release iq button after desired red LED flash for range setting (#6 is factory setting).

After releasing button, faucet will cycle through auto calibration (approximately 15-seconds). Then test faucet.

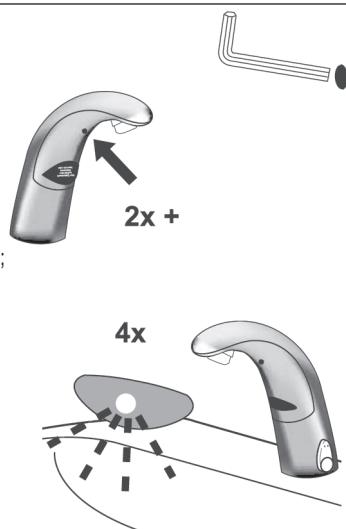

1 x (1x, 2x,...,8x)

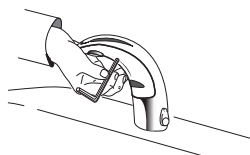

NOTE: Updated electronics have visible RED and GREEN LED. Original electronics have only RED LED and range setting is reversed (1 = longest, 8 = shortest)

BATTERY REPLACEMENT

Replace battery when RED LED indicator flashes each time faucet is in use or when faucet stops functioning.

Step 1

Close supply stop(s).

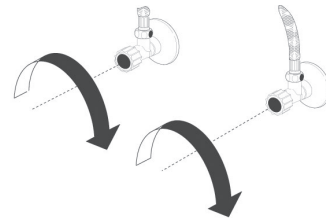

Step 2

Loosen screw with hex wrench. Remove throat plate. Disconnect electrical lead at connector if required.

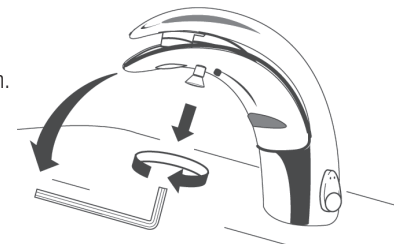

Step 3

Remove battery cover using a No. 1 Phillips head screwdriver. Remove old battery. Dispose of properly.

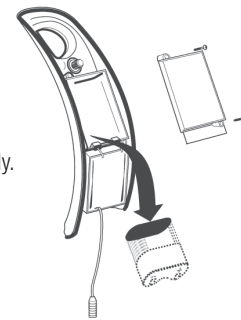

Step 4

Wait three (3) minutes before inserting new battery.



Step 5

Insert a new 6 volt type 2CR5 lithium battery. The RED LED will flash for one (1) minute.

Reinstall battery cover.

Reconnect electrical lead at connector if previously disconnected. Reinstall throat plate.

If LED doesn't flash or if it just lights up, remove the battery. Wait three (3) minutes, then reinsert the battery.

If water flows continuously after inserting the new battery and opening the supply stops, remove the battery. Wait three (3) minutes, then reinsert the battery.

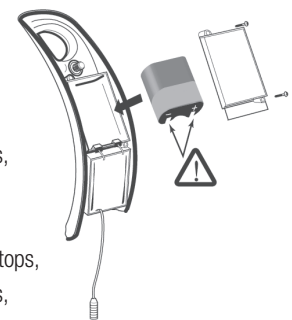

Step 6

Open supply stops.

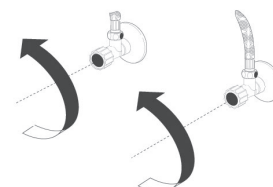

Optima® EAF-150 Faucet

SERVICE OPERATION

Prepare for operation

(A) When activating a new faucet (or new sensor replacement) for the first time, after removing protective label from sensor window, press sensor button one (1) time, then place hand or installation instructions within 1 to 2 inches in front of sensor until faucet activates water flow, remove hand or instructions,

water flow stops, red LED flashing ends followed with one (1) Green LED flash (approximately 12 seconds) Test faucet.

If waterflow DOES NOT start after removing the sticker and the RED LED within the sensor flashes continue with the following procedure!!

Place installation instructions within 1 to 2 inches in front of sensor until faucet activates water flow, then remove instructions, water flow stops, red LED flashing ends followed with one (1) Green LED flash (approximately 12 seconds). Test faucet.

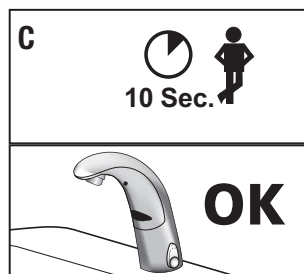
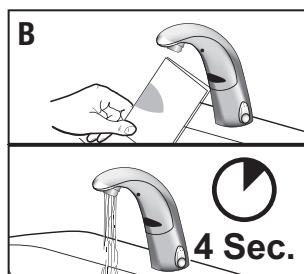
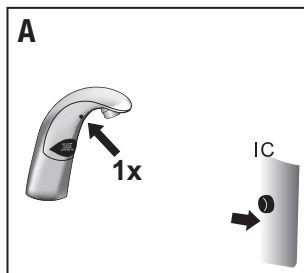
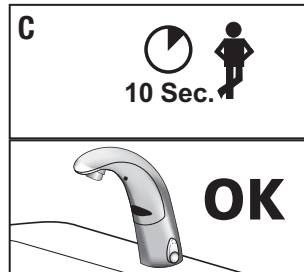
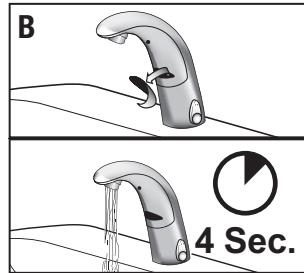
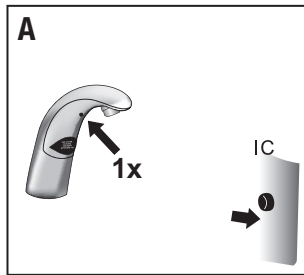

TROUBLESHOOTING GUIDE

1. Problem: Faucet not activating after installation.

Cause: Not properly started up. See step 5 on previous page.
 Solution: Remove adhesive label from sensor eye.
 Solution: Press button on faucet throat one time.

2. Problem: Faucet delivers water in an uncontrolled manner.

Cause: Faucet is not working properly.
 Solution: Contact the Sloan Technical Support at +1.888.756.2614.

3. Problem: Faucet does not deliver any water when Sensor is activated.

Indicator: Solenoid valve produces an audible "CLICK."
 Cause: Water supply stop(s) closed.
 Solution: Open water supply stop(s).
 Cause: Water supply stop strainer(s) clogged.
 Solution: Clean water supply stop strainer(s).
 Indicator: Solenoid valve DOES NOT produce an audible "CLICK."
 Cause: Battery low (EAF-150 Models).
 Solution: Replace battery (refer to Battery Replacement on Previous page).
 Cause: Power failure (EAF-100 Models).
 Solution: Check power supply.

4. Problem: Faucet delivers only a slow flow or dribble when Sensor is activated.

Cause: Water supply stop(s) are partially closed.
 Solution: Completely open water supply stop(s).
 Cause: Water supply stop strainer(s) clogged.
 Solution: Remove, clean, and reinstall water supply stop strainer(s). Replace strainer(s) if required.
 Cause: Aerator is clogged.
 Solution: Remove, clean, and reinstall Aerator. Replace Aerator if required.
 Cause: Faucet is not working properly.
 Solution: Contact the Sloan Valve Company Installation Engineering Department (see below).

5. Problem: Faucet drips between uses or runs on. Solenoid is heard activating

Cause: Debris caught in solenoid
 Solution: Clean Solenoid Valve - Turn off water, remove and unplug sensor/throat plate assembly with 2.5-mm hex wrench, remove solenoid using 6-mm hex wrench, clean solenoid diaphragm of plumbing debris, clean solenoid base in faucet with a dry towel, install solenoid (do not over-tighten), connect sensor/throat plate and install, dry fire solenoid (listen for clicking), then turn on water and test faucet. Also flush lines at stops as well to remove any plumbing debris in the line, check supply hose filters at that time as well.

6. Problem: LED indicator blinks when Faucet is in use.

Cause: Battery low (EAF-150 Models).
 Solution: Replace battery (refer to Battery Replacement on Previous Page)

7. Problem: i.q. - doesn't function (-IC models only)

Cause: Button is not working properly.
 Solution: Replace sensor throat plate; see parts breakdown on next page for correct sensor throat plate replacement (item #2B).

8. Problem: The water temperature is too hot or too cold on a Faucet connected to hot and cold supply lines.

CAUSE: Supply Stops are not adjusted properly.
 SOLUTION: Adjust Supply Stops.
 CAUSE: For models with integral mixing valve - Mixing valve is set improperly for the water temperature desired.
 SOLUTION: Rotate mixing valve handle clockwise to decrease water temperature or counterclockwise to increase water temperature.

Optima® EAF-100 Faucet

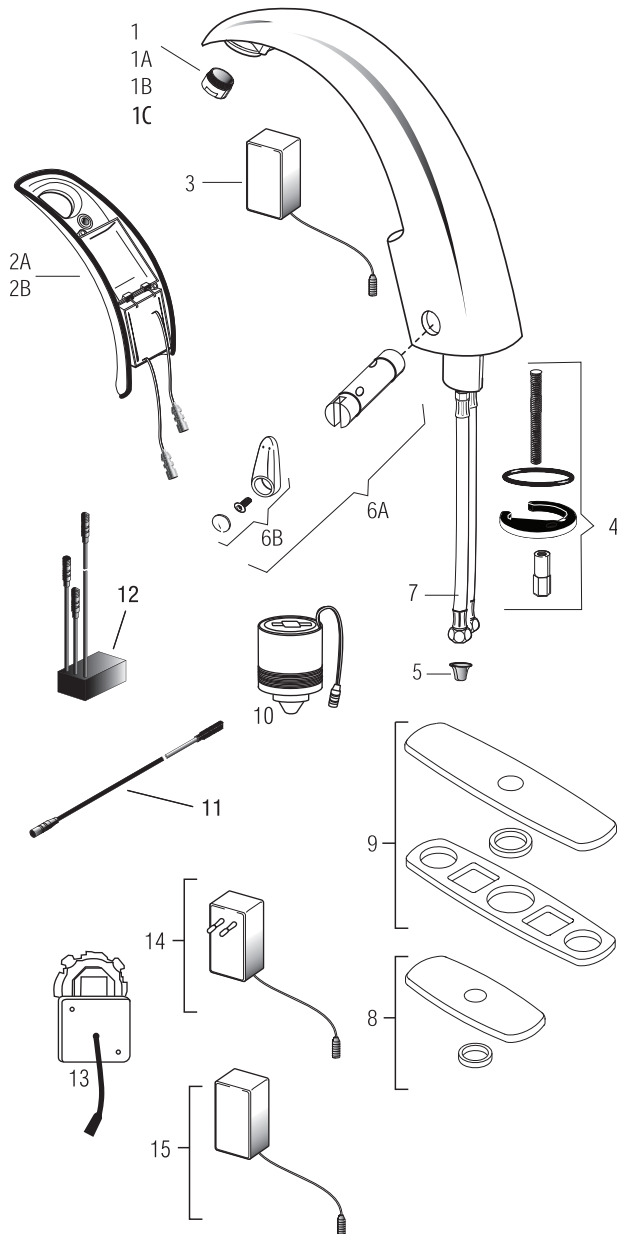

PARTS LIST—EAF-100 FAUCETS

Item No.	Code No.	Part No.	Description
1A	0335021	EAF-22	1.5 gpm (5.7 Lpm) Aerator Spray Head
1B	0335008	EAF-10	2.2 gpm (8.3 Lpm) Aerator Spray Head
1C	0335010	EAF-12	0.5 gpm (1.9 Lpm) Multi-Laminar Spray Head
1D	0335029	EAF-51	0.35 gpm (1.3 Lpm) Spray Head (Multi-Lam)
2A	0335004	EAF-6-A	Sensor Standard Throat Plate Assembly (Plug-in Adapter Models)
2B	0335005	EAF-7-A	Sensor standard throat plate assembly with i.q. click (Plug-in adapter models, IC variation)
3	0335009	EAF-11	90-264 VAC/6.75 VDC Plug-In Adapter (US)
4	0335000	EAF-1	Faucet Mounting Kit
5	0335007	EAF-9	Strainer (Filter) (One per package) - Note: 2 required for ISM Models
6A	3335118	EAF-1022-A	Side Mixer Cartridge & Handle
6B	3335011	EAF-1002	Handle Repair Kit
7	3335023	EAF-1008	15" (330 mm) Flexible Supply Hose (1)
8	0362011	SFP-11	Trim Plate for 4" Center-set Sink
9	3362022	SFP-22	Trim Plate for 8" Center-set Sink
10	0335001	EAF-2	Solenoid (Solenoid (6 mm hex recess))
11	0335024	EAF-24-A	11-13/16" (300 mm) Extension Cable
	0335025	EAF-25-A	47-1/4" (1200 mm) Extension Cable
	0335015	EAF-17-A	126" (3200 mm) Extension Cable
12.†	0335044	EAF-44-A	Power Splitter†
13	0335037	EAF-37	6 VDC Box Mount Adapter
14	0335038	EAF-38	90-264 VAC/6.75 VDC Plug-In Adapter (EURO)
15	0335039	EAF-39	90-264 VAC/6.75 VDC Plug-In Adapter (UK)

† EAF-44 replaces the separate EAF-23-A Splitter Cable and (Discontinued) EAF-28 Capacitor, which is sold separately.

EAF-1001 Mixer Handle Assembly and Cartridge (prior to 2004) Discontinued

EAF100 faucets require EAF44 POWER SPLITTER in ganging (or daisy chain) application.

Electrical Connection for up to Six (6) Faucets Using One (1) Adapter

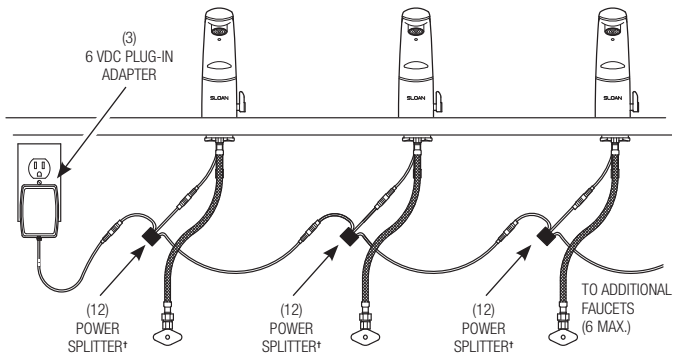

* EAF-100 faucets require use of EAF-44-A (12) Power Splitter in Ganging (Daisy Chain) Applications.

Optima® EAF-100 Faucet

AUTO SENSOR CALIBRATION OR RANGE ADJUSTMENT

For sensor recalibration, press and release iq button 2 quick times, wait for rapid "temporary off" red LED flashes, then press and hold iq button for several seconds and after four (4) slow red LED flashes, release button and step away for fifteen (15) seconds to allow faucet sensor to recalibrate.

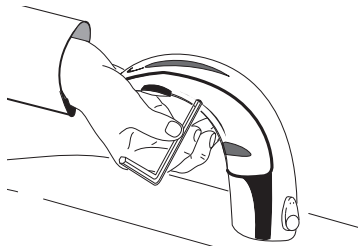

STANDARD MODELS

After water turns on then off and red LED flashes are followed by a single green flash (calibration complete), test faucet.

MANUAL RANGE ADJUSTMENT

To manually change range, press and release iq button 2 quick times, wait for rapid "temporary off" red LED flashes, then press and hold iq button, there will be four (4) red LED flashes, a pause, then more red LED flashes (up to eight (8) red LED flashes); 1-red LED flash for the shortest range setting, eight (8) flashes for the longest range setting;

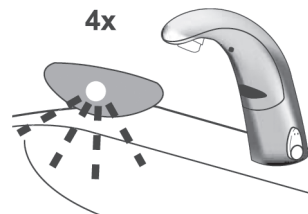
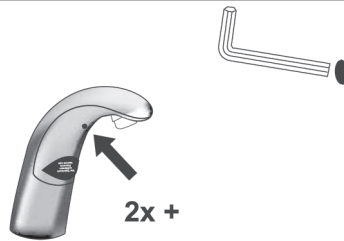

Release iq button after desired red LED flash for range setting (#6 is factory setting).

After releasing button, faucet will cycle through auto calibration (approximately 15-seconds). Then test faucet.

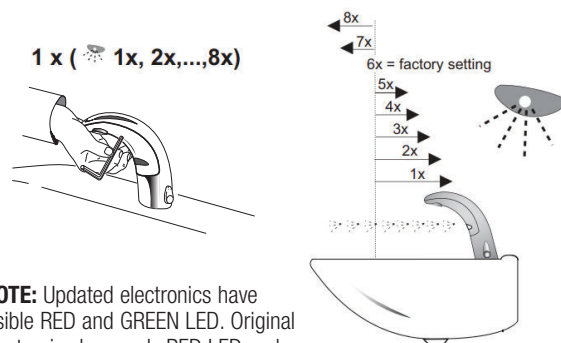

NOTE: Updated electronics have visible RED and GREEN LED. Original electronics have only RED LED and range setting is reversed (1 = longest, 8 = shortest)

SERVICE OPERATION

Prepare for operation

A. Press the button once.

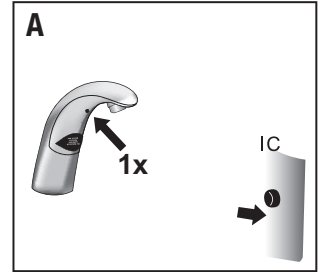

B. Remove sticker.



C. Water will flow 4 seconds



D. Wait 10 seconds, then the faucet is ready for use.



If waterflow doesn't start after removing the sticker and the red led within the sensor flashes continue with the following procedure!!

A. Press the button once.

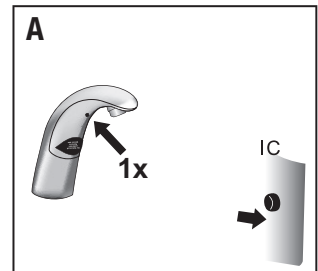

B. Hold a white sheet of paper 1.5" (40 mm) in front of sensor until water flows for 4 seconds



C. Remove paper.



D. Wait 10 seconds, then the faucet is ready for use.



Optima® EAF-100 Faucet

TROUBLESHOOTING GUIDE

1. Faucet DOES NOT function.

- A. Adhesive packaging label affixed over sensor eye. Remove adhesive label from sensor eye.
- B. "Permanent Off" activated. Press button on faucet throat one time.

2. Faucet delivers water in an uncontrolled manner.

- A. Faucet is not working properly. Contact Sloan Technical Support.

3. Faucet does not deliver any water when sensor is activated.

INDICATOR: Solenoid valve produces an audible "CLICK."

- A. Water supply stop(s) closed. Open water supply stop(s).
- B. Water supply stop strainer(s) clogged. Clean water supply stop strainer(s).

INDICATOR: Solenoid valve DOES NOT produce an audible "CLICK."

- A. Power failure (EAF-100 Models). Check power supply.

4. Faucet delivers only a slow flow or dribble when sensor is activated.

- A. Water supply stop(s) are partially closed. Completely open water supply stop(s).
- B. Water supply stop strainer(s) clogged. Remove, clean, and reinstall water supply stop strainer(s). Replace strainer(s) if required.
- C. Aerator is clogged. Remove, clean, and reinstall aerator. Replace aerator if required.
- D. Faucet is not working properly. Contact Sloan Technical Support.

5. Faucet DOES NOT stop delivering water or continues to drip after user is no longer detected.

- A. Clean Solenoid Valve - Turn off water, remove and unplug sensor/throat plate assembly with 2.5-mm hex wrench, remove solenoid using 6-mm hex wrench, clean solenoid diaphragm of plumbing debris, clean solenoid base in faucet with a dry towel, install solenoid (do not over-tighten), connect sensor/throat plate and install, dry fire solenoid (listen for clicking), then turn on water and test faucet. Also flush lines at stops as well to remove any plumbing debris in the line, check supply hose filters at that time as well.

6. i.q.-cliq DOES NOT function (-IC models only)

- A. Button is not working properly. Contact Sloan Technical Support.

7. The water temperature is too hot or too cold on a faucet connected to hot and cold supply lines.

- A. Supply stops are not adjusted properly. Adjust supply stops.
- B. For models with integral mixing valve — mixing valve is set improperly for the water temperature desired. Rotate mixing valve handle clockwise to decrease water temperature or counterclockwise to increase water temperature.

CARE AND CLEANING

DO NOT USE abrasive or chemical cleaners (including chlorine bleach) to clean faucets that may dull the luster and attack the chrome or special decorative finishes. Use **ONLY** mild soap and water, then wipe dry with clean cloth or towel.

While cleaning the bathroom tile, protect the faucet from any splattering of cleaner. Acids and cleaning fluids will discolor or remove chrome plating.

When assistance is required, please contact Sloan Technical Support at: 1-888-SLOAN-14 (1-888-756-2614).



Optima® EAF-250 Faucet



EAF-250

EAF-250 Series Faucet date code 1101 and newer. Product revised to make spray head vandal resistant without need for special spray. EAF-15 only works on product date code 1052 and older.

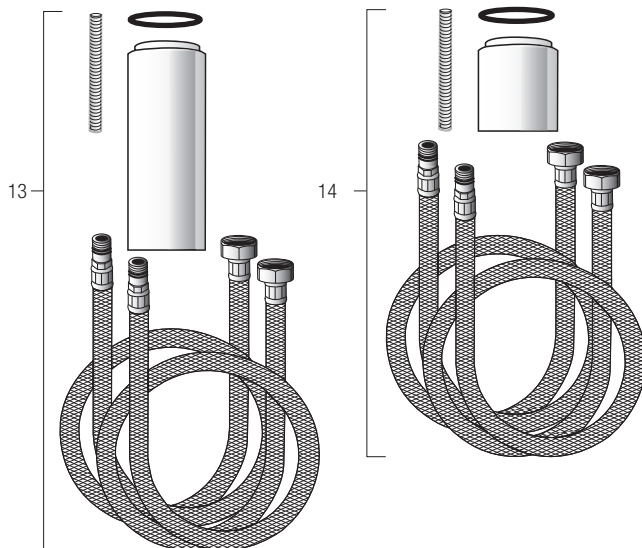
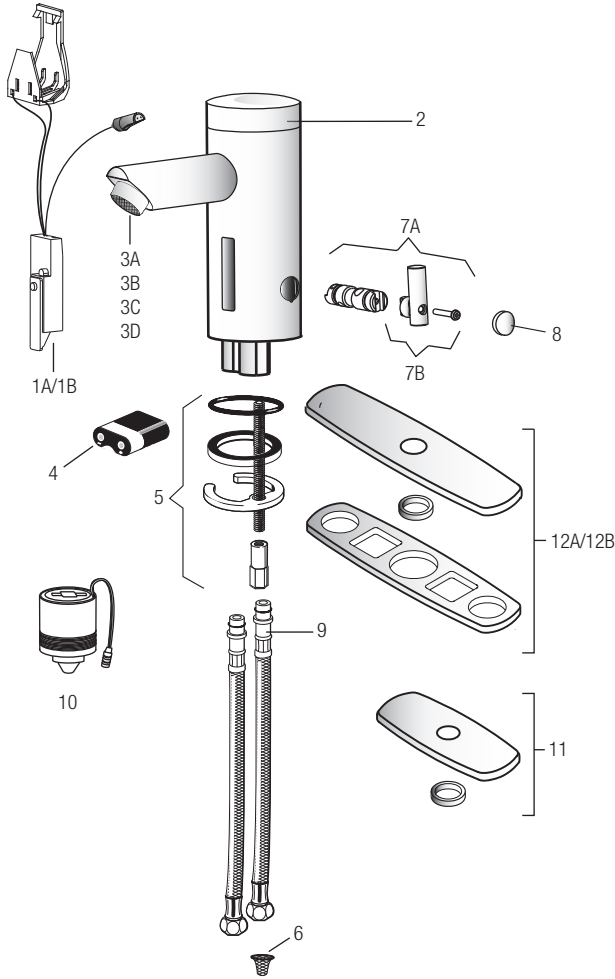

PARTS LIST—EAF-250 FAUCETS

Item No.	Code No.	Part No.	Description
1A.	0335019	EAF-21-A	Faucet Sensor Assembly without i.q.-cliq™
1B.	0335018	EAF-20-A	Faucet Sensor Assembly with i.q.-cliq™
2.	0335027	EAF-27	Cap
3A.	0335012	EAF-15	0.5 gpm (1.9 Lpm) VR Aerator Spray Head – Pre 03/2011
3B.	0335008	EAF-10	2.2 gpm (8.3 Lpm) Aerator Spray Head
3C.	0335011	EAF-13	2.2 gpm (8.3 Lpm) Laminar Flow Spray Head
3D.	0335029	EAF-51	0.35 gpm (1.3 Lpm) Multi-Laminar Spray Head
4.	3335018	EAF-1003	Battery Replacement Kit (CR-P2)
5.	0335000	EAF-1	Faucet Mounting Kit
6.	0335007	EAF-9	Strainer (Filter)
7A.	0335019	EAF-1004	Mixer Handle Assembly and Cartridge
7B.	3335020	EAF-1005	Handle Repair Kit
8.	3335022	EAF-1007	Handle Cap
9.	3335023	EAF-1008	13" (330 mm) Flexible Supply Hose (1)
10.	0335001	EAF-2	Solenoid (Solenoid (6 mm hex recess))
11.	3365468	ETF-312-A	Trim Plate for 4" Centerset Sink
	0362011	SFP-11-A	Use when needing 4" for EAF-35-A extension
12A.	3365024	ETF-510-A	Trim Plate for 8" Centerset Sink
12B.	3362022	SFP-22-A	Use when needing 8" for EAF-35-A extension
13.	3335035	EAF-35-A	6 3/4" Faucet Extension Kit
14.	3335046	EAF-40-A	2-1/8" Faucet Extension Kit. Raises faucet such that outlet height complies with California Office of Statewide Health Planning and Development

— = Not shown in illustration

i.q.-cliq™ SETTINGS

Function	Press Button	LED Signal
Continuous Run – 2 minute default setting (adjustable from 1 – 20 minutes)	1 time for 2 seconds	5 short flashes
reset:	1 time or will reset automatically after 2 minutes	
Temporary Off	2 times (double click) periodic flashing	5 short flashes followed by
reset:	1 time or will reset automatically after 2 minutes	
Auto Set Range Adjustment	2 times (double click) and then 1 time for 5 seconds	5 short flashes followed by 4 short flashes

Optima® EAF-250 Faucet

TROUBLESHOOTING GUIDE

1. Faucet DOES NOT function.

- A. "Permanent Off" activated. Press button on faucet throat one time.

2. Faucet delivers water in an uncontrolled manner.

- A. Faucet is not working properly. Contact Sloan Technical Support.

3. Faucet DOES NOT deliver any water when Sensor is activated.

INDICATOR: Solenoid valve produces an audible "CLICK."

- A. Water supply stop(s) closed. Open water supply stop(s).
 B. Water supply stop strainer(s) clogged. Remove, clean, and reinstall water supply stop strainer(s). Replace strainer(s) if required.

INDICATOR: Solenoid valve DOES NOT produce an audible "CLICK."

- A. Battery low (battery powered models). Replace battery (refer to Battery Replacement).

4. Faucet delivers only a slow flow or dribble when sensor is activated.

- A. Water supply stop(s) are partially closed. Completely open water supply stop(s).
 B. Water supply stop strainer(s) clogged. Remove, clean, and reinstall water supply stop strainer(s). Replace strainer(s) if required.
 C. Aerator is clogged. Remove, clean, and reinstall Aerator. Replace Aerator if required.
 D. Faucet is not working properly. Contact Sloan Technical Support.

5. Faucet DOES NOT stop delivering water or continues to drip after user is no longer detected.

- A. Faucet is not working properly. Contact Sloan Technical Support.

6. LED indicator blinks when faucet is in use.

- A. Battery low (battery powered models). Replace battery (refer to Battery Replacement on page 250).

7. The water temperature is too hot or too cold on a faucet connected to hot and cold supply lines.

- A. Supply stops are not adjusted properly. Adjust supply stops.
 B. For models with integral mixing valve – Mixing valve is set improperly for the water temperature desired. Rotate mixing valve handle clockwise to decrease water temperature or counterclockwise to increase water temperature.

OPERATION

As the user's hands enter the beam's effective range, the beam is reflected back into the sensor receiver and activates the solenoid valve allowing water to flow from the faucet. Water will flow until the hands are removed or until the faucet reaches its automatic time out limit setting.

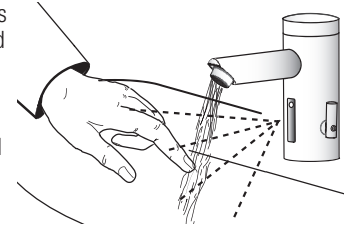

CARE AND CLEANING

DO NOT use abrasive or chemical cleaners (including chlorine bleach) to clean faucet that may dull the luster and attack the chrome or special decorative finishes. Use **ONLY** mild soap and water, then wipe dry with clean cloth or towel.

While cleaning the bathroom tile, protect the faucet from any splattering of cleaner. Acids and cleaning fluids will discolor or remove chrome plating.

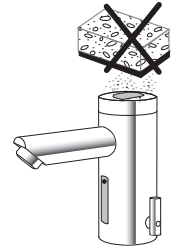

When assistance is required, please contact Sloan Technical Support at: 1-888-SLOAN-14 (1-888-756-2614).

Optima® EAF-200 Faucet



EAF-200

EAF-200 Series Faucet date code 1101 and newer. Product revised to make spray head vandal resistant without need for special spray. EAF-15 only works on product date code 1052 and older.

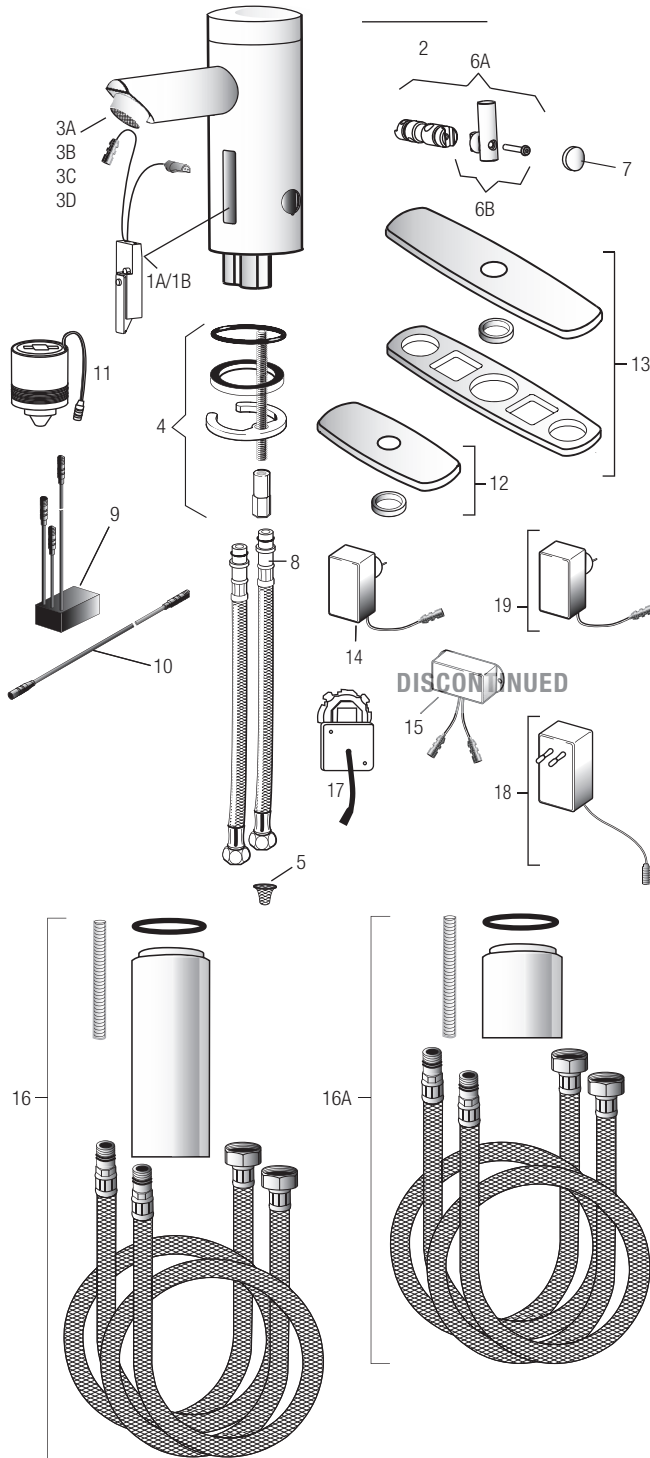

PARTS LIST—EAF-200 FAUCETS

Item No.	Code No.	Part No.	Description
1A.	0335016	EAF-18-A	Faucet Sensor Assembly with i.q.-cliq
1B.	0335017	EAF-19-A	Faucet Sensor Assembly without i.q.-cliq
2.	0335027	EAF-27	Cap
3A.	0335012	EAF-15	0.5 gpm (1.9 Lpm) VR Aerator Spray Head – Pre-03/2011
3B.	0335008	EAF-10	2.2 gpm (8.3 Lpm) Aerator Spray Head
3C.	0335011	EAF-13	2.2 gpm (8.3 Lpm) Laminar Flow Spray Head
3D.	0335029	EAF-51	0.35 gpm (1.3 Lpm) Multi-Laminar Spray Head
4.	0335000	EAF-1	Faucet Mounting Kit
5.	0335007	EAF-9	Strainer (Filter)
6A.	3335019	EAF-1004	Mixer Handle Assembly and Cartridge
6B.	3335020	EAF-1005	Handle Repair Kit
7.	3335022	EAF-1007	Handle Cap
8.	3335023	EAF-1008	13" (330 mm) Flexible Supply Hose (1)
9.	0335044	EAF-44	Power Splitter†
10.	0335024	EAF-24-A	11-13/16" (300 mm) Ext. Cable (Model EAF-200)
	0335025	EAF-25-A	47-1/4" (1200 mm) Ext. Cable (Model EAF-200)
	0335015	EAF-17-A	126" (3200 mm) Ext. Cable (Model EAF-200)
11.	0335001	EAF-2	Solenoid
12.	3365468	ETF-312-A	Trim Plate for 4" Centerset Sink
13.	3365024	ETF-510-A	Trim Plate for 8" Centerset Sink
14.	0335009	EAF-11	(Model EAF-200) 90-264 VAC/6.75 VDC Plug-In Adapter (US)
15.	0335028	EAF-28	Capacitor Box (Model EAF-200) – DISCONTINUED
16.	3335035	EAF-35-A	6 3/4" Faucet Extension Kit
16A.	3335046	EAF-40-A	2-1/8" Faucet Extension Kit. Raises faucet such that outlet height complies with California Office of Statewide Health Planning and Development
17.	0335037	EAF-37	6 VDC Box Mount Voltage Adapter
18.	0335038	EAF-38	90-264 VAC/6.75 VDC Plug-In Adapter (EURO)
19.	0335039	EAF-39	90-264 VAC/6.75 VDC Plug-In Adapter (UK)

†EAF-44 replaces the separate EAF-23-A Splitter Cable and EAF-28 Capacitor, which is sold separately.

i.q.-cliq SETTINGS

Function	Press Button	LED Signal
Continuous Run – 2 minute default setting (adjustable from 1 – 20 minutes)	1 time for 2 seconds	5 short flashes
reset:	1 time or will reset automatically after 2 minutes	
Temporary Off	2 times (double click) by periodic flashing	5 short flashes followed by periodic flashing
reset:	1 time or will reset automatically after 2 minutes	
Auto Set Range Adjustment	2 times (double click) and then 1 time for 5 seconds	5 short flashes followed by 4 short flashes

Electrical Connection for up to Six (6) Faucets Using One (1) Adapter

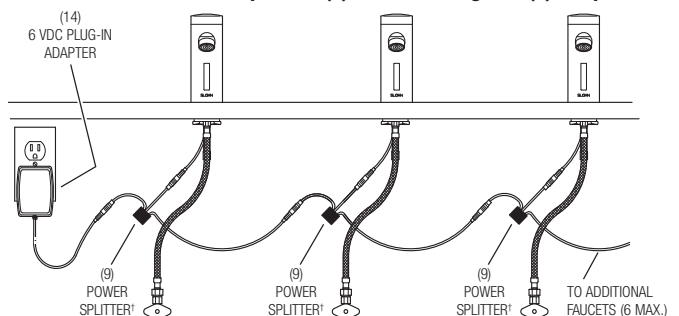

Optima® EAF-200 Faucet

TROUBLESHOOTING GUIDE

1. Faucet DOES NOT function.

- A. "Permanent Off" activated. Press button on faucet throat one time.

2. Faucet delivers water in an uncontrolled manner.

- A. Faucet is not working properly. Contact Sloan Technical Support.

3. Faucet DOES NOT deliver any water when Sensor is activated.

INDICATOR: Solenoid valve produces an audible "CLICK."

- A. Water supply stop(s) closed. Open water supply stop(s).
 B. Water supply stop strainer(s) clogged. Remove, clean, and reinstall water supply stop strainer(s). Replace strainer(s) if required.

INDICATOR: Solenoid valve DOES NOT produce an audible "CLICK."

- A. Power failure (EAF-200 Models). Check power supply.

4. Faucet delivers only a slow flow or dribble when sensor is activated.

- A. Water supply stop(s) are partially closed. Completely open water supply stop(s).
 B. Water supply stop strainer(s) clogged. Remove, clean, and reinstall water supply stop strainer(s). Replace strainer(s) if required.
 C. Aerator is clogged. Remove, clean, and reinstall Aerator. Replace Aerator if required.
 D. Faucet is not working properly. Contact Sloan Technical Support.

5. Faucet DOES NOT stop delivering water or continues to drip after user is no longer detected.

- A. Faucet is not working properly. Contact Sloan Technical Support.

6. The water temperature is too hot or too cold on a faucet connected to hot and cold supply lines.

- A. Supply Stops are not adjusted properly. Adjust Supply Stops.
 B. For models with integral mixing valve – Mixing valve is set improperly for the water temperature desired. Rotate mixing valve handle clockwise to decrease water temperature or counterclockwise to increase water temperature.

OPERATION

As the user's hands enter the beam's effective range, the beam is reflected back into the sensor receiver and activates the solenoid valve allowing water to flow from the faucet. Water will flow until the hands are removed or until the faucet reaches its automatic time out limit setting.

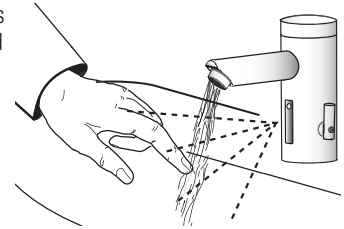

CARE AND CLEANING INSTRUCTIONS

DO NOT USE abrasive or chemical cleaners including chlorine bleach) to clean faucet that may dull the luster and attack the chrome or special decorative finishes. Use **ONLY** mild soap and water, then wipe dry with clean cloth or towel.

While cleaning the bathroom tile, protect the faucet from any splattering of cleaner. Acids and cleaning fluids will discolor or remove chrome plating.

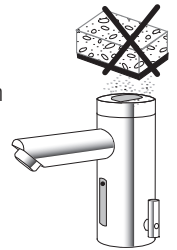

When assistance is required, please contact Sloan Technical Support at: 1-888-SLOAN-14 (1-888-756-2614).

Optima® EAF-225 Faucet



EAF-225

EAF-225 Series Faucet date code 1101 and newer. Product revised to make spray head vandal resistant without need for special spray. EAF-15 only works on product date code 1052 and older.

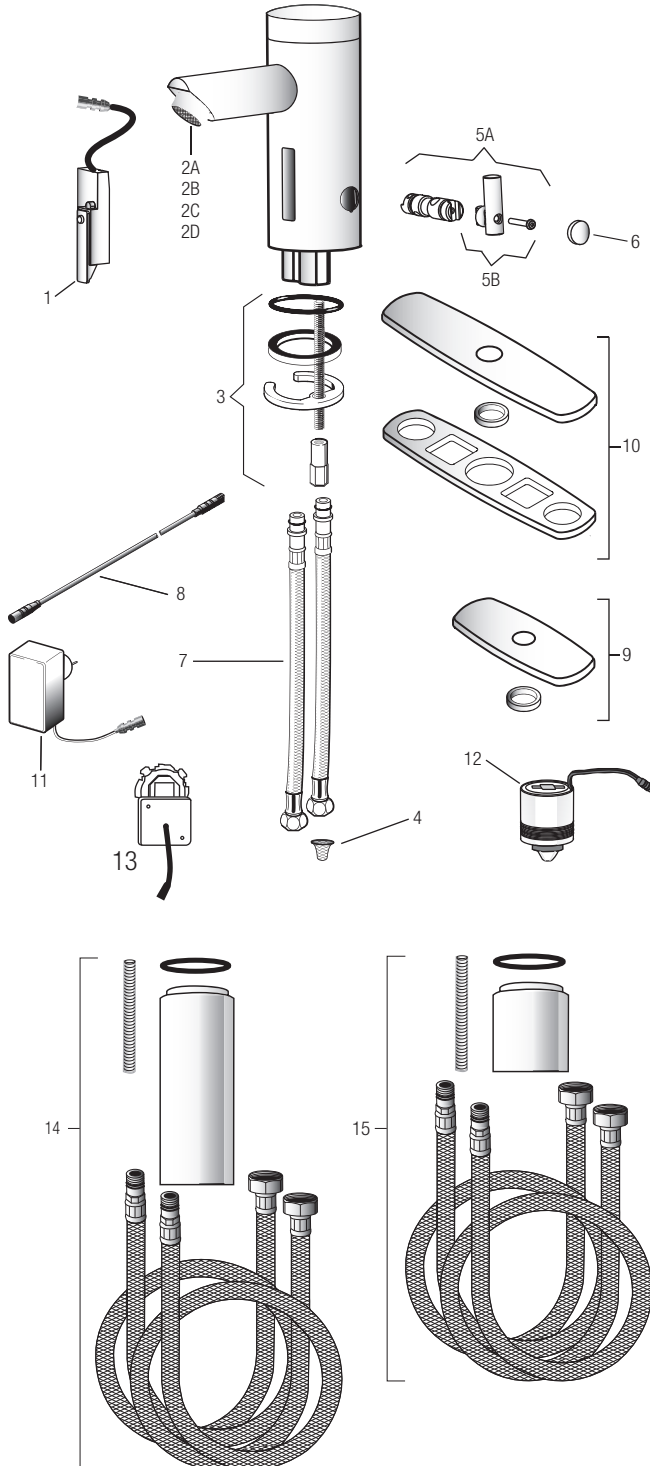

PARTS LIST—EAF-225 FAUCET

Item No.	Code No.	Part No.	Description
1.	0335016	EAF-18-A	Faucet Sensor Assembly with i.q.-Click
2A.	0335012	EAF-15	0.5 gpm (1.9 Lpm) VR Pressure Compensating Spray Head – Pre 03/2011
2B.	0335021	EAF-22	1.5 gpm (5.6 Lpm) Pressure Compensating Aerated Stream
2C.	0335008	EAF-10	2.2 gpm (8.3 Lpm) Aerator Spray Head
2D.	0335011	EAF-13	2.2 gpm (8.3 Lpm) Laminar Flow Spray Head
3.	0335000	EAF-1	Faucet Mounting Kit
4.	0335007	EAF-9	Strainer (Filter)
5A.	3335019	EAF-1004	Mixer Handle Assembly and Cartridge
5B.	3335020	EAF-1005	Handle Repair Kit
6.	3335022	EAF-1007	Handle Cap
7.	3335023	EAF-1008	13" (330 mm) Flexible Supply Hose (1)
8.	0335024	EAF-24-A	11-13/16" (300 mm) Extension Cable
	0335025	EAF-25-A	47-1/4" (1200 mm) Extension Cable
	0335015	EAF-17-A	126" (3200 mm) Extension Cable
9.	3365468	ETF-312-A	Trim Plate for 4" Centerset Sink
10.	3365024	ETF-510-A	Trim Plate for 8" Centerset Sink
11.	0335009	EAF-11	Plug-in Adapter
12.	0335001	EAF-2	Solenoid
13.	0335037	EAF-37	6 VDC Box Mount Voltage Adapter
14.	3335035	EAF-35-A	6 3/4" Faucet Extension Kit
15.	3335046	EAF-40-A	2-1/8" Faucet Extension Kit. Raises faucet such that outlet height complies with California Office of Statewide Health Planning and Development

Note: Multiple Lumino faucets CANNOT be installed with one voltage adapter due to power requirements of light ring. (1) faucet per (1) EAF-37

i.q.-cliq SETTINGS

Function	Press Button	LED Signal
Continuous Run – 2 minute default setting (adjustable from 1 – 20 minutes)	1 time for 2 seconds	5 short flashes
reset:	1 time or will reset automatically after 2 minutes	
Temporary Off	2 times (double click) periodic flashing	5 short flashes followed by
reset:	1 time or will reset automatically after 2 minutes	
Auto Set Range Adjustment	2 times (double click) and then 1 time for 5 seconds	5 short flashes followed by 4 short flashes

Optima® EAF-225 Faucet

TROUBLESHOOTING GUIDE

1. Faucet DOES NOT function.

- A. Adhesive packaging label affixed over sensor eye. Remove adhesive label from sensor eye.
- B. "Permanent Off" activated. Press button on faucet throat one time.

2. Faucet delivers water in an uncontrolled manner.

- A. Faucet is not working properly. Contact Sloan Technical Support.

3. Faucet DOES NOT deliver any water when Sensor is activated.

INDICATOR: Solenoid valve produces an audible "CLICK."

- A. Water supply stop(s) closed. Open water supply stop(s).
- B. Water supply stop strainer(s) clogged. Remove, clean, and reinstall water supply stop strainer(s). Replace strainer(s) if required.

INDICATOR: Solenoid valve DOES NOT produce an audible "CLICK."

- A. Battery low (battery powered models). Replace battery.
- B. Power failure (EAF-200 Models). Check power supply.

4. Faucet delivers only a slow flow or dribble when sensor is activated.

- A. Water supply stop(s) are partially closed. Completely open water supply stop(s).
- B. Water supply stop strainer(s) clogged. Remove, clean, and reinstall water supply stop strainer(s). Replace strainer(s) if required.

5. Faucet delivers only a slow flow or dribble when sensor is activated.

- A. Aerator is clogged. Remove, clean, and reinstall Aerator. Replace Aerator if required.
- B. Faucet is not working properly. Contact Sloan Technical Support.

6. Faucet DOES NOT stop delivering water or continues to drip after user is no longer detected.

- A. Faucet is not working properly. Contact Sloan Technical Support.

7. LED indicator blinks when faucet is in use.

- A. Battery low (battery powered models). Replace battery.

8. The water temperature is too hot or too cold on a faucet connected to hot and cold supply lines.

- A. Supply Stops are not adjusted properly. Adjust supply stops.
- B. For models with integral mixing valve — Mixing valve is set improperly for the water temperature desired. Rotate mixing valve handle clockwise to decrease water temperature or counterclockwise to increase water temperature.

OPERATION

As the user's hands enter the beam's effective range, the beam is reflected back into the sensor receiver and activates the solenoid valve allowing water to flow from the faucet. Water will flow until the hands are removed or until the faucet reaches its automatic time out limit setting.

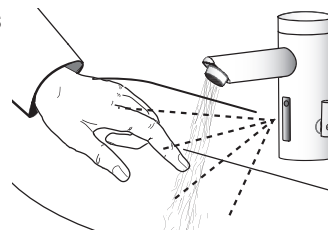

CARE AND CLEANING INSTRUCTIONS

DO NOT USE abrasive or chemical cleaners (including chlorine bleach) to clean faucet that may dull the luster and attack the chrome or special decorative finishes. Use **ONLY** mild soap and water, then wipe dry with clean cloth or towel.

While cleaning the bathroom tile, protect the faucet from any splattering of cleaner. Acids and cleaning fluids will discolor or remove chrome plating.

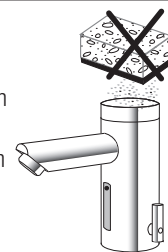

When assistance is required, please contact Sloan Technical Support at: 1-888-SLOAN-14 (1-888-756-2614).

Optima® EAF-350 Faucets



EAF-350-ISM



EAF-350

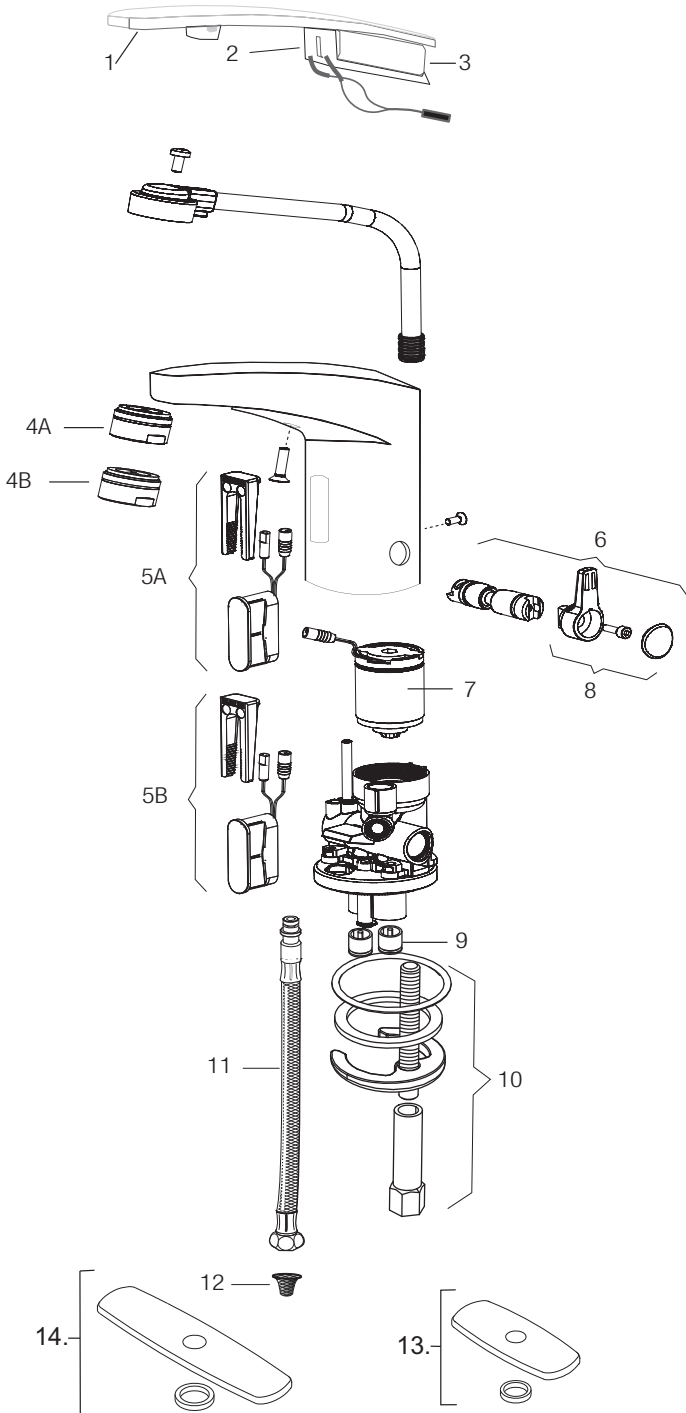

PARTS LIST—EAF-350 FAUCETS

Item No.	Code No.	Part No.	Description
1.	0335040	EAF-60	Cover
2.	0335043	EAF-61	Battery Clip and Cable with Screw
3.	3335018	EFX-1003A	Battery Replacement Kit (with 2.5 mm hex key)
4A.	0335021	EAF-22	1.5 gpm (5.6 Lpm) AER Spray Head
4B.	0335036	EAF-63	0.5 gpm (1.9 Lpm) AER Spray Head
5A.	3335116	EAF-1021-A	Electronic Sensor (15 Second Shut-off) with Fixing Clip Kit (0.5 gpm only)
5B.	3335113	EAF-1018-A	Electronic Sensor (7 Second Shut-off) with Fixing Clip Kit (1.5 gpm only)
6.	3335114	EAF-1019-A	Mixer Handle Assembly and Cartridge Kit
7.	0335001	EAF-2	Solenoid Valve Cartridge (IQ Faucet) (6 mm hex recess)
8.	0335115	EAF-1020-A	Handle Repair Kit
9.	0335006	EAF-8	Back Check (2 required for ISM models)
10.	0335000	EAF-1	Faucet Mounting Kit
11.	3335023	EAF-1008	13" (330 mm) Flexible Supply Hose (1) (2 required for ISM models)
12.	0335007	EAF-9	Filter Kit (2 per kit)
13.	0362011	SFP11	4" Trimplate
14.	3362022	SFP-22	8" Trimplate

IR-Click Settings

Enter Programming Mode first before accessing the IR features of the faucet. To enter Programming Mode, cover the bottom half of sensor with finger, wait 2 seconds for Orange light, then remove finger. When in programming mode, each touch of IR-Click will produce a quick Orange flash. Programming Mode window lasts five (5) seconds before closing. If a function is not enacted within 5 seconds of entering Programming Mode, enter Programming Mode again.

Function	Touch IR Sensor	LED Signal
Temporary OFF (2 min)	1. 1 time for 3 seconds 2. 2 times (double push)	1. LED Orange (1) 2. LED Red pulsating flashes
reset:	1 time or will reset automatically after 2 mins	
Continuous Run 2 minute default setup (adjustable from 1-20 mins)	1. 1 time for 3 seconds 2. 1 time for 3-5 seconds	1. LED Orange (1) 2. Water flows after releasing
reset:	1 time or will reset automatically after 2 mins	
Sensor Range Adjustment	1. 1 time for 3 seconds 2. 2 times (double touch) 3. 1 time for 5 seconds then hold till requested range is reached 4. Release	1. LED Orange (1) 2. LED Red blinks 3. LED Red (1-8) 4. LED Orange (1)

Note: Older models have Green and Red LED lights.

Optima® EAF-350 Faucet

TROUBLESHOOTING GUIDE

1. Faucet DOES NOT function.

- A. "Permanent Off" activated. Press button on faucet throat one time.

2. Faucet delivers water in an uncontrolled manner.

- A. Faucet is not working properly. Contact Sloan Technical Support.

3. Faucet DOES NOT deliver any water when Sensor is activated.

INDICATOR: Solenoid valve produces an audible "CLICK."

- A. Water supply stop(s) closed. Open water supply stop(s).
 B. Water supply stop strainer(s) clogged. Remove, clean, and reinstall water supply stop strainer(s). Replace strainer(s) if required.

INDICATOR: Solenoid valve DOES NOT produce an audible "CLICK."

- A. Battery low (battery powered models). Replace battery (refer to Battery Replacement).

4. After removing label water does not flow.

Use this installation guide as a target by placing it in front of the sensor (approx. 1-1/2" away) until water begins flowing, then remove installation instruction from sensor. Water will stop flowing, wait 10 seconds before using faucet.

5. Faucet delivers only a slow flow or dribble when sensor is activated.

- A. Water supply stop(s) are partially closed. Completely open water supply stop(s).
 B. Water supply stop strainer(s) clogged. Remove, clean, and reinstall water supply stop strainer(s). Replace strainer(s) if required.
 C. Aerator is clogged. Remove, clean, and reinstall Aerator. Replace Aerator if required.
 D. Faucet is not working properly. Contact Sloan Technical Support.

6. Faucet DOES NOT stop delivering water or continues to drip after user is no longer detected.

- A. Faucet is not working properly. Contact Sloan Technical Support.

7. LED indicator blinks when faucet is in use.

- A. Battery low (battery powered models). Replace battery.

8. The water temperature is too hot or too cold on a faucet connected to hot and cold supply lines.

- A. Supply stops are not adjusted properly. Adjust supply stops.
 B. For models with integral mixing valve – Mixing valve is set improperly for the water temperature desired. Rotate mixing valve handle clockwise to decrease water temperature or counterclockwise to increase water temperature.

OPERATION

As the user's hands enter the beam's effective range, the beam is reflected back into the sensor receiver and activates the solenoid valve allowing water to flow from the faucet. Water will flow until the hands are removed or until the faucet reaches its automatic time out limit setting.

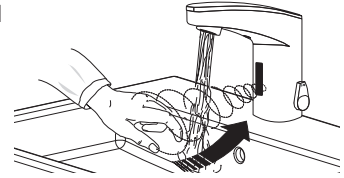

CARE AND CLEANING

DO NOT use abrasive or chemical cleaners (including chlorine bleach) to clean faucet that may dull the luster and attack the chrome or special decorative finishes. Use **ONLY** mild soap and water, then wipe dry with clean cloth or towel.

While cleaning the bathroom tile, protect the faucet from any splattering of cleaner. Acids and cleaning fluids will discolor or remove chrome plating.

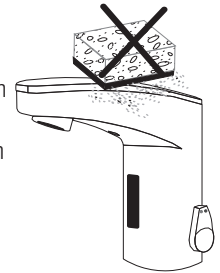

When assistance is required, please contact Sloan Technical Support at: 1-888-SLOAN-14 (1-888-756-2614).

Optima® EAF-750 Faucet

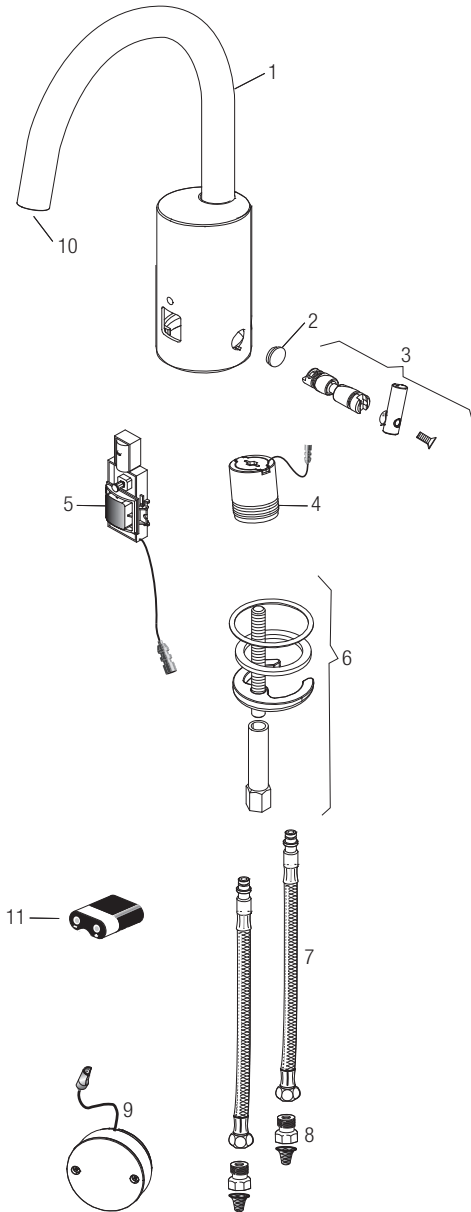

PARTS LIST—EAF-750 FAUCETS

Item			
No.	Code No.	Part No.	Description
1.	—	—	Spout Assembly
2.	3335022	EAF-1007	Integral Side Mixer Handle Cap
3.	3335019	EAF-1004	Integral Side Mixer Kit
4.	0335001	EAF-2	Solenoid
5.	3335099	EAF-1017-A	Sensor Assembly
6.	0335000	EAF-1	Mounting Hardware
7.	3335023	EAF-1008	13" (330 mm) Flexible Supply Hose (1)
8.	0335007	EAF-9	Filter/Strainer
9.	0335048	EAF-48	Battery Box
10.	3335086	EAF-1014-A	Multi-Lam Spray Head Kit 0.5 gpm (1.9 Lpm) Male Cache TJ
	3335087	EAF-1015-A	Spray Head Kit 1.5 gpm (5.7 Lpm) Aerated Male Cache TJ
	3335088	EAF-1016-A	Spray Head Kit 1.5 gpm (5.7 Lpm) Laminar Male Cache TJ
11.	3335018	EAF-1003	Battery Replacement Kit (CR-P2)

Optima® EAF-750 Faucet

OPERATION

As the user's hands enter the beam's effective range, the beam is reflected back into the sensor receiver and activates the solenoid valve allowing water to flow from the faucet. Water will flow until the hands of the user are removed or until the faucet reaches its automatic time out limit setting.

SET AND FIX TEMPERATURE (OPTIONAL)

Step 1

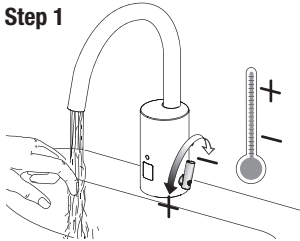

Step 3

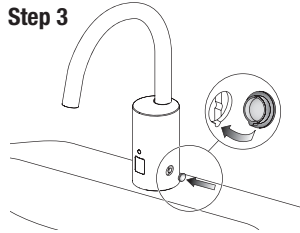

Step 2

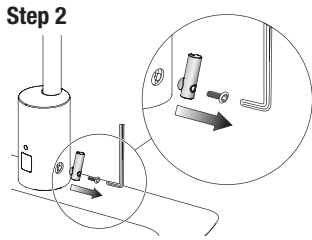

HOT LIMIT STOP ADJUSTMENT

Limit the maximum water temperature. Note: this does not take the place of an ASSE 1070 certified mixing device. But is an added measure to limit delivery of hot water.

Step 1

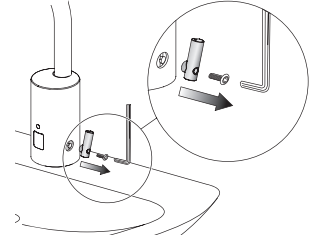

Step 4

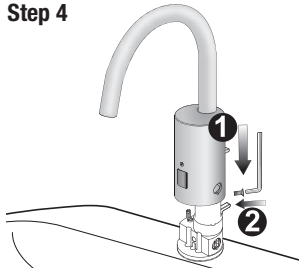

Step 2

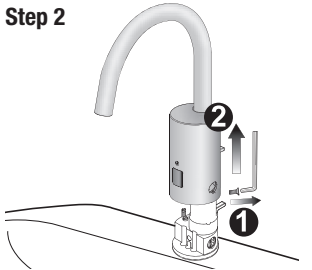

Step 5

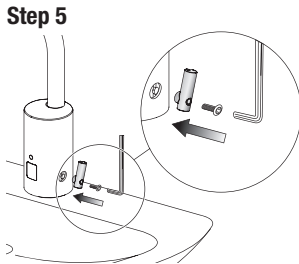

Step 3

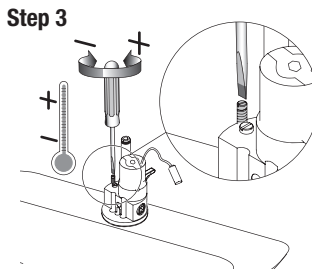

SENSOR RANGE ADJUSTMENT

Factory setting is appropriate for the majority of applications and should not require resetting unless under extreme situations.

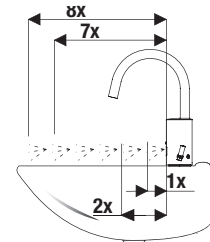

FACTORY DEFAULT = 6

Step 1

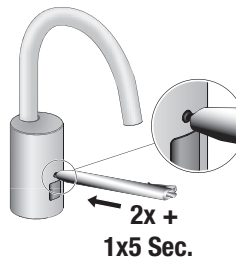

Step 4

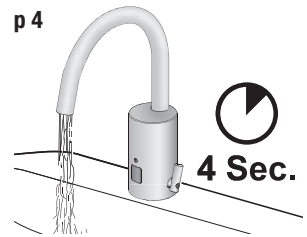

Step 2

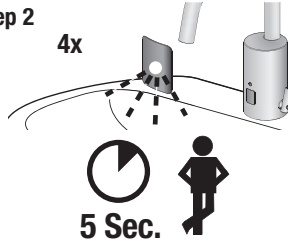

Step 5



Step 3

1 x (1x, 2x,...,5x)

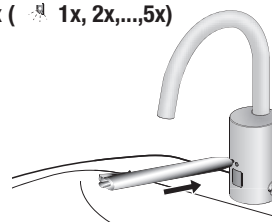

12/24 LINE PURGE FEATURE

This feature will operate the faucet every 12 or 24 hours since last use, if not used to prevent stagnant water conditions.

Default purge duration is two (2) minutes.

Consult factory regarding other timing options.

1x 24 sec

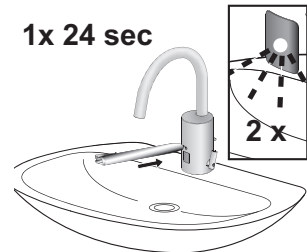

Optima® EAF-750 Faucet

I.Q.-CLICK FEATURE

1. CONTINUOUS RUN

Continuous run of water for two minutes.

Faucet will operate normally after two minutes or after pressing i.q.-click button once.

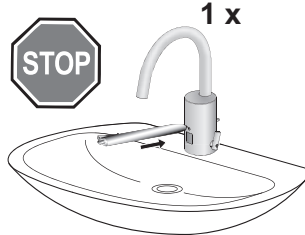
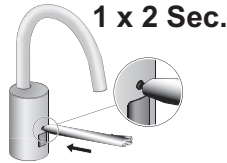

2. CLEANING MODE

Pause faucet for cleaning for two (2) minutes.

Faucet will operate normally after two (2) minutes or after pressing i.q.-click button once.

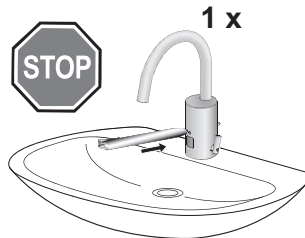
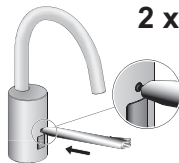

OFF-DELAY (FOLLOW UP TIME)

Duration of time the water runs after target is removed.

Press the button for approximately six (6) seconds. Release.

Press again (water flows) and release when the desired time of water flow (0-5 seconds) is reached.

Sensor will flash once and then the faucet is ready to operate.

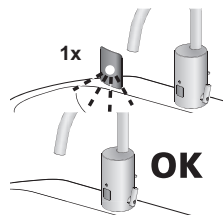

BATTERY REPLACEMENT

Note: Replace battery when red LED indicator flashes each time faucet is in use or when faucet stops functioning.

No need to turn off water.

Loosen screw with hex wrench and remove cap. Slide cover forward and lift off.

Remove battery.

Replace batteries with new "CR-P2" lithium battery (Sloan Kit# EAF-1003A).

Replace cover.

Activate faucet by pressing i.q. cliq one (1) time, then immediately step away.

Faucet will operate for four (4) seconds.

Wait 10 seconds and then the faucet is ready for operation.

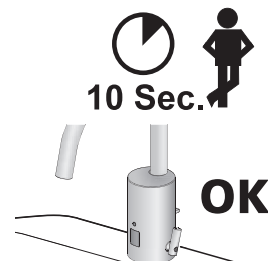
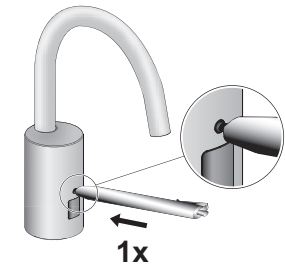
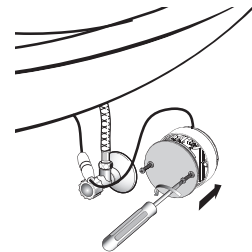
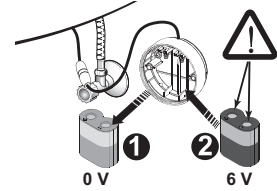
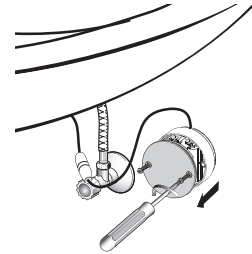

Optima® EAF-700 Faucet

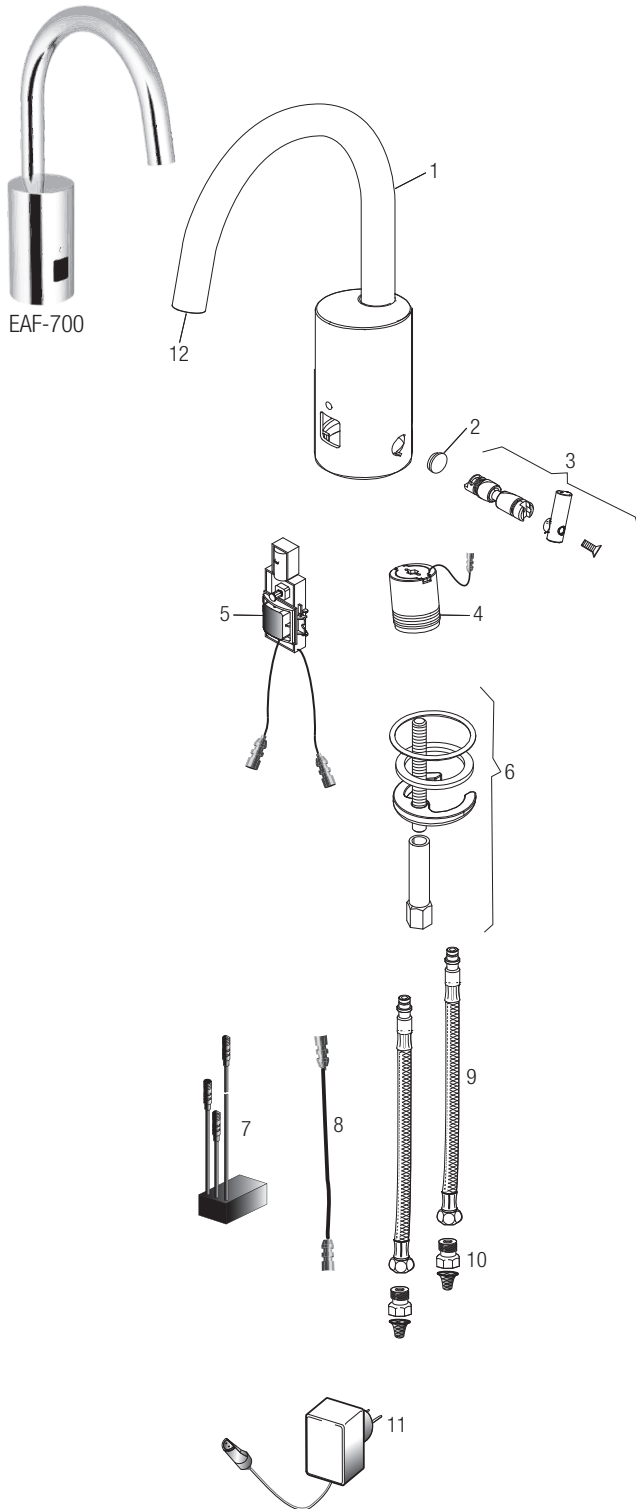

PARTS LIST—EAF-700 FAUCETS

Item No.	Code No.	Part No.	Description
1.	—	—	Spout Assembly
2.	3335022	EAF-1007	Integral Side Mixer Handle Cap
3.	3335019	EAF-1004	Integral Side Mixer Kit
4.	0335001	EAF-2	Solenoid
5.	3335099	EAF-1017-A	Sensor Assembly
6.	0335000	EAF-1	Mounting Hardware
7.	0335044	EAF-44	Power Splitter
8.	0335024	EAF-24-A	11-13/16" (300 mm) Extension Cable
	0335025	EAF-25-A	47-1/4" (1200 mm) Extension Cable
	0335015	EAF-17-A	126" (3200 mm) Extension Cable
9.	3335023	EAF-1008	13" (330 mm) Flexible Supply Hose (1)
10.	0335007	EAF-9	Filter/Strainer
11.	0335009	EAF-11-A	Plug-in Voltage Adapter, US Plug
12.	3335086	EAF-1014-A	Multi-Lam Spray Head Kit 0.5 gpm (1.9 Lpm) Male Cache TJ
	3335087	EAF-1015-A	Spray Head Kit 1.5 gpm (5.7 Lpm) Aerated Male Cache TJ
	3335088	EAF-1016-A	Spray Head Kit 1.5 gpm (5.7 Lpm) Laminar Male Cache TJ

*Not Shown: SFP-11 4" Trimplate / SFP-22 8" Trimplate

Electrical Connection for up to Six (6) Faucets Using One (1) Adapter

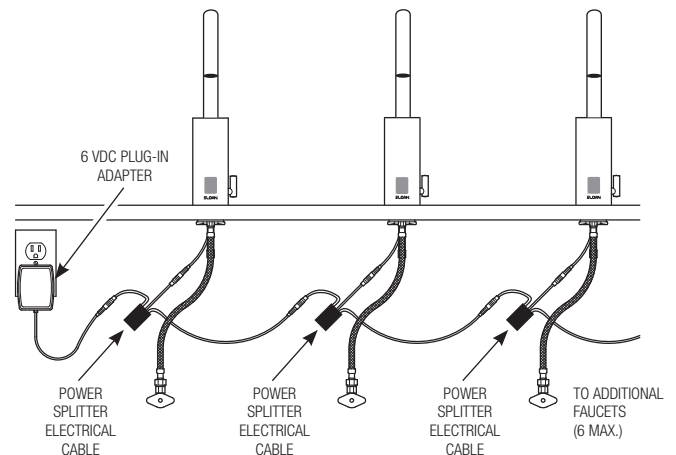

Optima® EAF-700 Faucet

OPERATION

As the user's hands enter the beam's effective range, the beam is reflected back into the sensor receiver and activates the solenoid valve allowing water to flow from the faucet. Water will flow until the hands of the user are removed or until the faucet reaches its automatic time out limit setting.

SET AND FIX TEMPERATURE (OPTIONAL)

Step 1

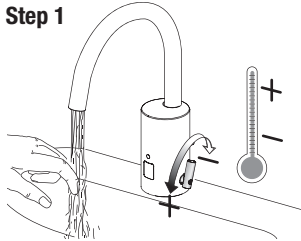

Step 3

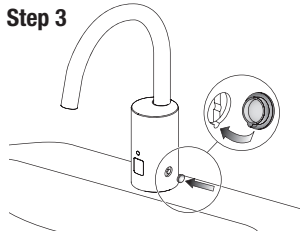

Step 2

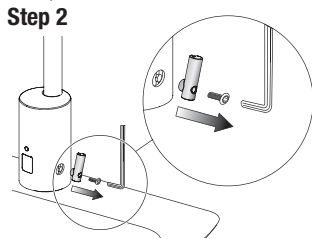

HOT LIMIT STOP ADJUSTMENT

Limit the maximum water temperature. **NOTE:** This **DOES NOT** take the place of an ASSE 1070 certified mixing device. But is an added measure to limit delivery of hot water.

Step 1

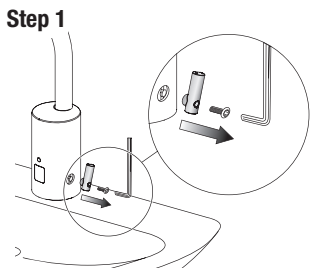

Step 4

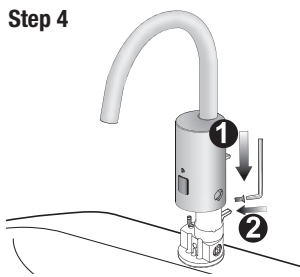

Step 2

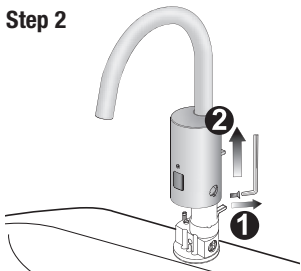

Step 5

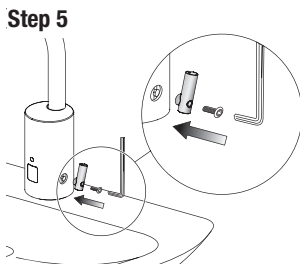

Step 3

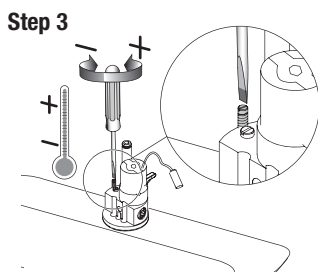

SENSOR RANGE ADJUSTMENT

Factory setting is appropriate for the majority of applications and should not require resetting unless under extreme situations.

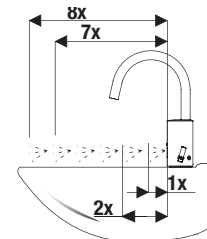

FACTORY DEFAULT = 6

Step 1

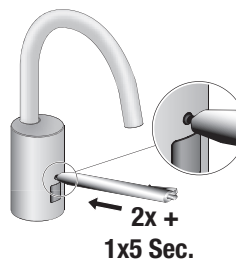

p 4

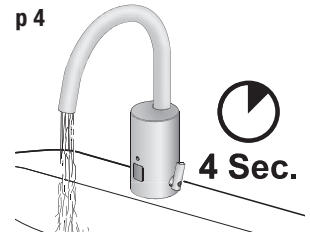

Step 2

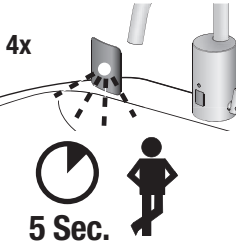

Step 5

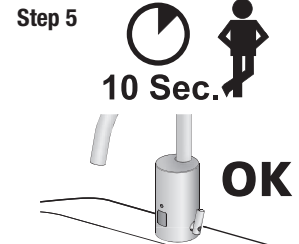

Step 3

1 x (1x, 2x,...,5x)

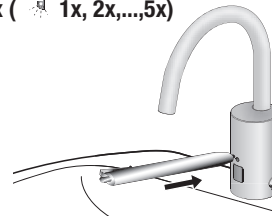

Optima® EAF-700 Faucet

12/24 LINE PURGE FEATURE

This feature will operate the faucet every 12 or 24 hours since last use, if not used to prevent stagnant water conditions.

Default purge duration is two (2) minutes.

Consult factory regarding other timing options.

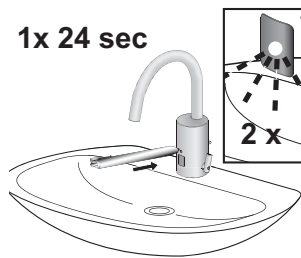

OFF-DELAY (FOLLOW UP TIME)

Duration of time the water runs after target is removed.

Press the button for approximately six (6) seconds. Release.

Press again (water flows) and release when the desired time of water flow (0-5 seconds) is reached.

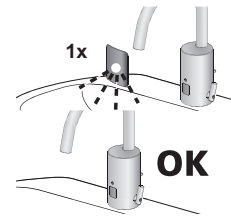
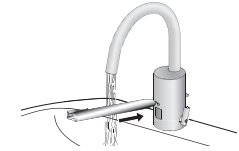

I.Q.-CLICK FEATURE

1. CONTINUOUS RUN

Continuous run of water for two minutes.

Faucet will operate normally after two minutes or after pressing i.q.-click button once.

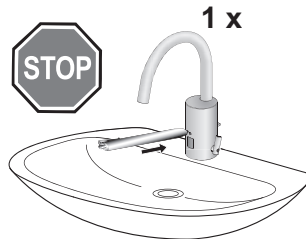
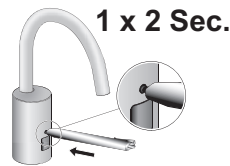

2. CLEANING MODE

Pause faucet for cleaning for two (2) minutes.

Faucet will operate normally after two (2) minutes or after pressing i.q.-click button once.

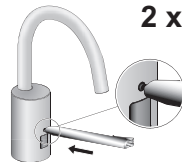

Optima® EAF-700 Faucet

TROUBLESHOOTING GUIDE

1. Faucet DOES NOT function.

- A. Adhesive packaging label affixed over sensor eye. Remove adhesive label from sensor eye.
- B. "Intermittent Off" is activated. Press button once.
- C. Water supply stop(s) closed. Open water supply stop(s).
- D. Battery is "dead". Replace battery (refer to Battery Replacement section of guide).

2. Faucet delivers water in an uncontrolled manner.

- A. Reflection. Remove reflective surface.
- B. Faucet is not working properly. Contact Sloan Technical Support.

3. Faucet DOES NOT deliver any water when sensor is activated.

INDICATOR: Solenoid valve produces an audible "CLICK."

- A. Water supply stop(s) closed. Open water supply stop(s).
- B. Water supply stop strainer(s) clogged. Remove, clean, and reinstall water supply stop strainer(s). Replace strainer(s), if required.

INDICATOR: Solenoid valve DOES NOT produce an audible "CLICK."

- A. Power failure. Check power supply.

4. Faucet delivers only a slow flow or dribble when sensor is activated.

- A. Water supply stop(s) are partially closed. Completely open water supply stop(s).
- B. Water supply stop strainer(s) clogged. Remove, clean, and reinstall water supply stop strainer(s). Replace strainer(s), if required.
- C. Spray head is clogged. Remove, clean, and reinstall spray head. Replace spray head, if required.
- D. Faucet is not working properly. Contact Sloan Technical Support.

5. Faucet DOES NOT stop delivering water or continues to drip after user is no longer detected.

- A. Faucet is not working properly. Contact Sloan Technical Support.

6. The water temperature is too hot or too cold on a faucet connected to hot and cold supply lines.

- A. Supply stops are not adjusted properly. Adjust supply stops.

CARE AND CLEANING

DO NOT USE abrasive or chemical cleaners (including chlorine bleach) to clean faucets that may dull the luster and attack the chrome or special decorative finishes. Use **ONLY** mild soap and water, then wipe dry with clean cloth or towel.

While cleaning the bathroom sink, protect the faucet from any splattering of cleaner. Acids and cleaning fluids will discolor or remove chrome plating.



When assistance is required, please contact Sloan Technical Support at: 1-888-SLOAN-14 (1-888-756-2614).

SF-2100/SF-2150 & SF-2200/SF-2250 Faucets

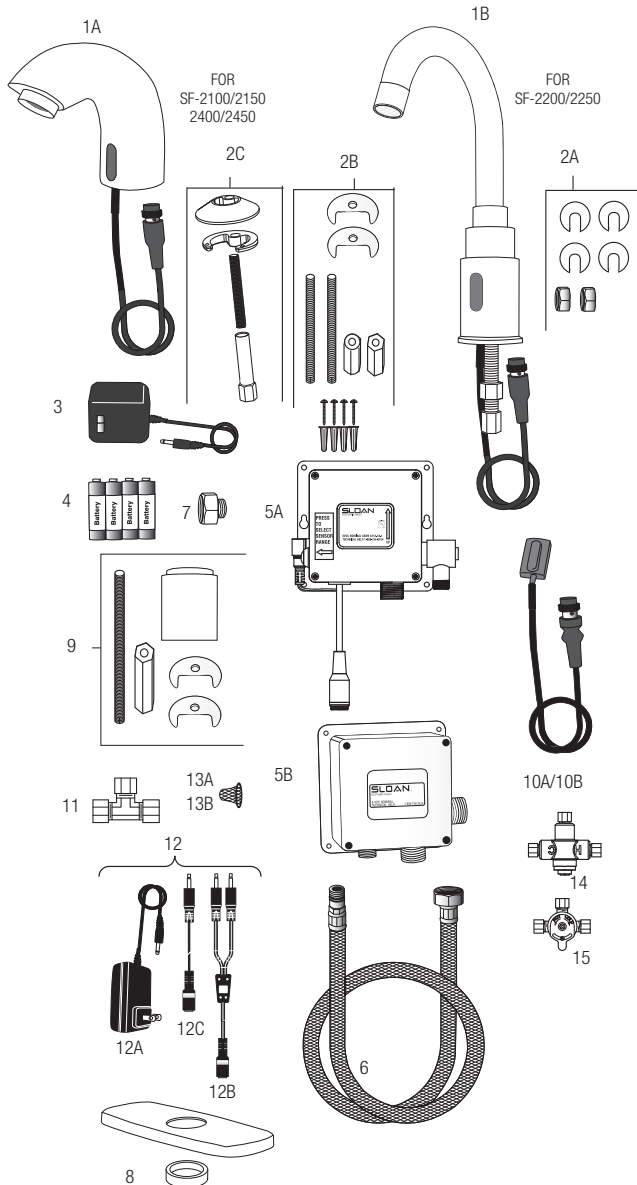

PARTS LIST—SF-2100/SF-2150/SF-2200/SF-2250

Item No.	Code No.	Part No.	Description
1A.	—	—	Pedestal Faucet Assembly w/Outlet (Models SF-2100 and SF-2150)
1B.	—	—	Gooseneck Faucet Assembly w/Outlet (Models SF-2200 and SF-2250)
	0362005	SFP-5	Mounting Hardware Kit, Screws and Anchors for Control Module (all models)
2A.	—	SFP-1004	Mounting Hardware Kit, Pedestal Faucet (Models SF-2200/SF-2250)
2B.	0362004	SFP-4	Mounting Hardware Kit, Pedestal Faucet (Models SF-2100/SF-2150) (Pre 3/2010)
2C.		SFP-44	Mounting Hardware Kit for SF-2100/2150 (Post 3/2010)
3.	0362006	SFP-6	110 VAC/6 VDC Plug-In Adapter (US) (Models SF-2100 and SF-2200)
4.	—	—	Batteries, 4 AA-size (all models)
5A.	0362040	SFP-40-A	Control module w/ adjustable button (6 pin connector)
5B.	0362008	SFP-8	Control module (Prior 8/2008-4 pin connector)*
6.	0362010	SFP-10	Flex Hose, Control Module to Spout (all models)
7.	0362045	SFP-45-A	Inlet adapter – 1/2" NPSM to 3/8" compression connection (not supplied with most international models)
8.	0362011	SFP-11	4" Trim Plate with Spacer (all models)
9.	0362030	SFP-30A	Faucet Extension Kit (Models SF-2100/2150)
10A.	0362041	SFP-41-A	Sensor Assembly (6 pin connector)
10B.	0362034	SFP-34	Sensor Assembly (Prior 8/2008-4 pin connector)*
11.	3365461	ETF-617-A	3/8" Bak-Chek® Tee Compression Fitting

* IMPORTANT: Sloan added the range adjustment feature in August 2008 for faucets made prior to August 2008 use the following replacement parts: SFP-34 and SFP-8

NOT SHOWN SEPARATELY

—	0335029	EAF-51	0.35 gpm (1.3 Lpm) spray head (Models SF-2100/2150)
—	0335012	EAF-15	0.5 gpm (1.9 Lpm) vandal resistant spray head (Models SF-2100/2150)
—	3362000	SFP-1000	0.35 gpm (1.3 Lpm) vandal resistant spray head (Models SF-2100/2150)
—	0362012	SFP-12	Gooseneck Spout w/Outlet (Models SF-2200/2250)
—	0362013	SFP-13	0.5 gpm (1.9 Lpm) spray head (Models SF-2100/2150)
—	0362014	SFP-14	Spray head for Gooseneck Faucet (Models SF-2200/2250)
—	0362023	SFP-23	2.2 gpm (8.3 Lpm) Aerator (Models SF-2100/2150)
—	0362024	SFP-24	2.2 gpm (8.3 Lpm) vandal resistant aerator (Models SF-2100/2150)
—	0362020	SFP-26	220 VAC/6 VDC Plug-In Adapter (ASIA)
—	0362025	SFP-25	220 VAC/6 VDC Plug-In Adapter (EURO)
—	0362026	SFP-20	220 VAC/6 VDC Plug-In Adapter (UK)
—	3362022	SFP-22-A	8" Trim Plate

ACCESSORIES

12.	0362035	SFP-35-A	100-240 VAC/6 VDC Gang Adapter Kit, includes 12A, 12B and 12C
12A.	0362016	SFP-36-A	100-240 VAC/6 VDC Plug-In Adapter
12B.	0362018	SFP-38	Cable Splitter, 51" (1300 mm) – 5 included in kit
12C.	0362017	SFP-37	Cable Extension, 51" (1300 mm)

REPAIR PARTS

13A.	0362015	SFP-15	Strainer For SFP8 and SFP40A modules with straight inlet (Prior to year 2011).
13B.	3315028	EBF-1004-A	Strainer For SFP40A modules with right angle inlet. (Year 2011 to present).
14.	0326045	MIX-135-A	Below Deck Thermostatic Mixing Valve
15.	3326009	MIX-60-A	Below Deck Mechanical Valve Mixing Valve

— in Item No. column = Not shown in illustration

— in Code No. and Part No. column = Not sold separately

SF-2100/SF-2150 & SF-2200/SF-2250 Faucets

TROUBLESHOOTING GUIDE

1. Faucet delivers water in an uncontrolled manner.

A. Faucet is not working properly. Contact Sloan Technical Support.

2. Faucet DOES NOT deliver any water when sensor is activated.

INDICATOR: Solenoid valve produces an audible “CLICK.”

A. Water supply stop(s) closed. Open water supply stop(s).

B. Water strainer in control module is clogged. Close supply stops and remove water inlet line at control module. Remove, clean and reinstall strainer and water inlet line. Replace strainer if required.

INDICATOR: Solenoid valve DOES NOT produce an audible “CLICK.”

A. Batteries low (battery powered models). Replace batteries.

B. Power failure (adapter powered models). Check power supply.

3. Faucet delivers only a slow flow or dribble when sensor is activated.

A. Water supply stop(s) are partially closed. Completely open water supply stop(s).

B. Water strainer in control module is clogged. Close supply stops and remove water inlet line at control module. Remove, clean and reinstall strainer and water inlet line. Replace strainer if required.

C. Aerator is clogged. Remove, clean, and reinstall aerator. Replace aerator if required.

D. Faucet is not working properly. Contact Sloan Technical Support.

4. Faucet DOES NOT stop delivering water or continues to drip after user is no longer detected.

A. Faucet is not working properly. Contact Sloan Technical Support.

5. The water temperature is too hot or too cold on a Faucet connected to hot and cold supply lines.

A. Supply stops are not adjusted properly. Adjust supply stops.

CARE AND CLEANING

DO NOT USE abrasive or chemical cleaners (including chlorine bleach) to clean faucet that may dull the luster and attack the chrome or special decorative finishes. Use **ONLY** mild soap and water, then wipe dry with clean cloth or towel. While cleaning the bathroom tile, protect the faucet from any splattering of cleaner. Acids and cleaning fluids will discolor or remove chrome plating.

When assistance is required, please contact Sloan Technical Support at: 1-888-SLOAN-14 (1-888-756-2614).

SF-2300/SF-2350 Faucets

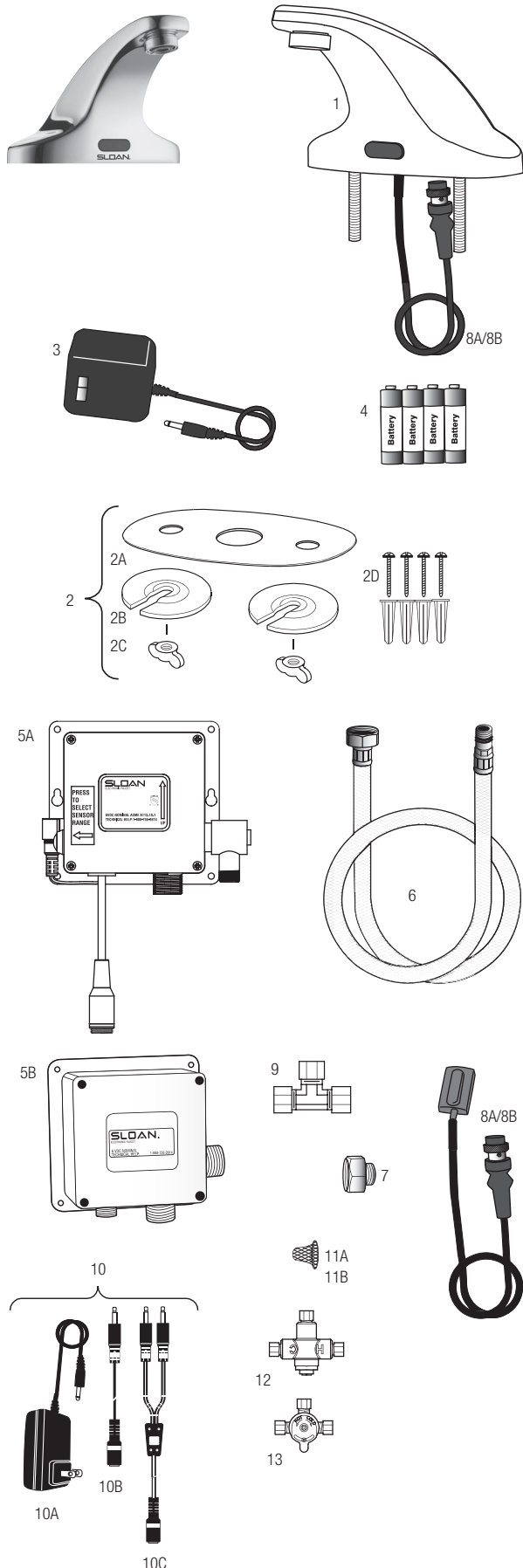

PARTS LIST—SF-2300/SF-2350

Item No.	Code No.	Part No.	Description
1.	—	—	Faucet Assembly w/Outlet
2.	—	SFP-16	Mounting Hardware Kit: includes Items 2A, 2B, 2C and 2D
2A.	—	—	Compression Fitting
2B.	—	—	Washers (2)
2C.	—	—	Wing Nuts (2)
2D.	—	—	Screws and Anchors for Control Module
3.	0362006	SFP-6	110 VAC/6 VDC Plug-In Adapter (US) (Model SF-2300 only)
4.	—	—	Batteries, 4 AA-size (all models)
5A.	0362040	SFP-40-A	Control Module with Adjustable Button (6 pin connector)
5B.	0362008	SFP-8	Control Module (Old Style 4 pin connector)*
6.	0362010	SFP-10	Flex Hose, Control Module to Spout
7.	0362045	SFP-45-A	Inlet adapter – 1/2" NPSM to 3/8" Compression Connection (not supplied with most international models)
8A.	0362041	SFP-41-A	Sensor Assembly (6 pin connector)
8B.	0362034	SFP-34	Sensor Assembly (Old Style 4 pin connector)*
9.	3365461	ETF-617-A	3/8" Bak-Chek® Tee Compression Fitting

* IMPORTANT: Sloan added the range adjustment feature in August 2008 for faucets made prior to August 2008 use the following replacement parts: SFP-34 and SFP-8

NOT SHOWN SEPARATELY

—	0335029	EAF-51	0.35 gpm (1.3 Lpm) spray head
—	0335012	EAF-15	0.5 gpm (1.9 Lpm) vandal resistant spray head
—	3362000	SFP-1000	0.35 gpm (1.3 Lpm) vandal resistant spray head
—	0362013	SFP-13	0.5 gpm (1.9 Lpm) Spray head
—	0362023	SFP-23	2.2 gpm (8.3 Lpm) Aerator
—	0362024	SFP-24	2.2 gpm (8.3 Lpm) vandal resistant aerator
—	0362020	SFP-26	220 VAC/6 VDC Plug-In Adapter (ASIA)
—	0362025	SFP-25	220 VAC/6 VDC Plug-In Adapter (EURO)
—	0362026	SFP-20	220 VAC/6 VDC Plug-In Adapter (UK)

ACCESSORIES

10.	0362035	SFP-35-A	100-240 VAC/6 VDC Gang Adapter Kit, includes 10A, 10B and 10C
10A.	0362016	SFP-36-A	100-240 VAC/6 VDC Plug-In Adapter
10B.	0362017	SFP-37	Cable Extension, 51" (1300 mm)
10C.	0362018	SFP-38	Cable Splitter, 51" (1300 mm) – 5 included in kit

REPAIR PARTS

11A.	0362015	SFP-15	Strainer For SFP8 and SFP40A modules with straight inlet (Prior to year 2011).
11B.	3315028	EBF-1004-A	Strainer For SFP40A modules with right angle inlet. (Year 2011 to present).
12.	0326045	MIX-135-A	Below Deck Thermostatic Mixing Valve
13.	3326009	MIX-60-A	Below Deck Mechanical Valve Mixing Valve

— in Item No. column = Not shown in illustration
 — in Code No. and Part No. column = Not sold separately

SF-2300/SF-2350 Faucets

TROUBLESHOOTING GUIDE

1. Faucet delivers water in an uncontrolled manner.

A. Faucet is not working properly. Contact Sloan Technical Support.

2. Faucet DOES NOT deliver any water when Sensor is activated.

INDICATOR: Solenoid valve produces an audible “CLICK.”

A. Water supply stop(s) closed. Open water supply stop(s).

B. Water strainer in control module is clogged. Close supply stops and remove water inlet line at control module. Remove, clean and reinstall strainer and water inlet line. Replace strainer if required.

INDICATOR: Solenoid valve DOES NOT produce an audible “CLICK.”

A. Batteries low (battery powered models). Replace batteries.

B. Power failure (adapter powered models). Check power supply.

3. Faucet delivers only a slow flow or dribble when Sensor is activated.

A. Water supply stop(s) are partially closed. Completely open water supply stop(s).

B. Water strainer in control module is clogged. Close supply stops and remove water inlet line at control module. Remove, clean and reinstall strainer and water inlet line. Replace strainer if required.

C. Aerator is clogged. Remove, clean, and reinstall aerator. Replace aerator if required.

D. Faucet is not working properly. Contact Sloan Technical Support.

4. Faucet DOES NOT stop delivering water or continues to drip after user is no longer detected.

A. Faucet is not working properly. Contact Sloan Technical Support.

5. The water temperature is too hot or too cold on a faucet connected to hot and cold supply lines.

A. Supply Stops are not adjusted properly. Adjust Supply Stops.

CARE AND CLEANING INSTRUCTIONS

DO NOT USE abrasive or chemical cleaners (including chlorine bleach) to clean faucet that may dull the luster and attack the chrome or special decorative finishes. Use **ONLY** mild soap and water, then wipe dry with clean cloth or towel.

While cleaning the bathroom tile, protect the faucet from any splattering of cleaner. Acids and cleaning fluids will discolor or remove chrome plating.

When assistance is required, please contact Sloan Technical Support at: 1-888-SLOAN-14 (1-888-756-2614).

SF-2400/SF-2450 Faucets

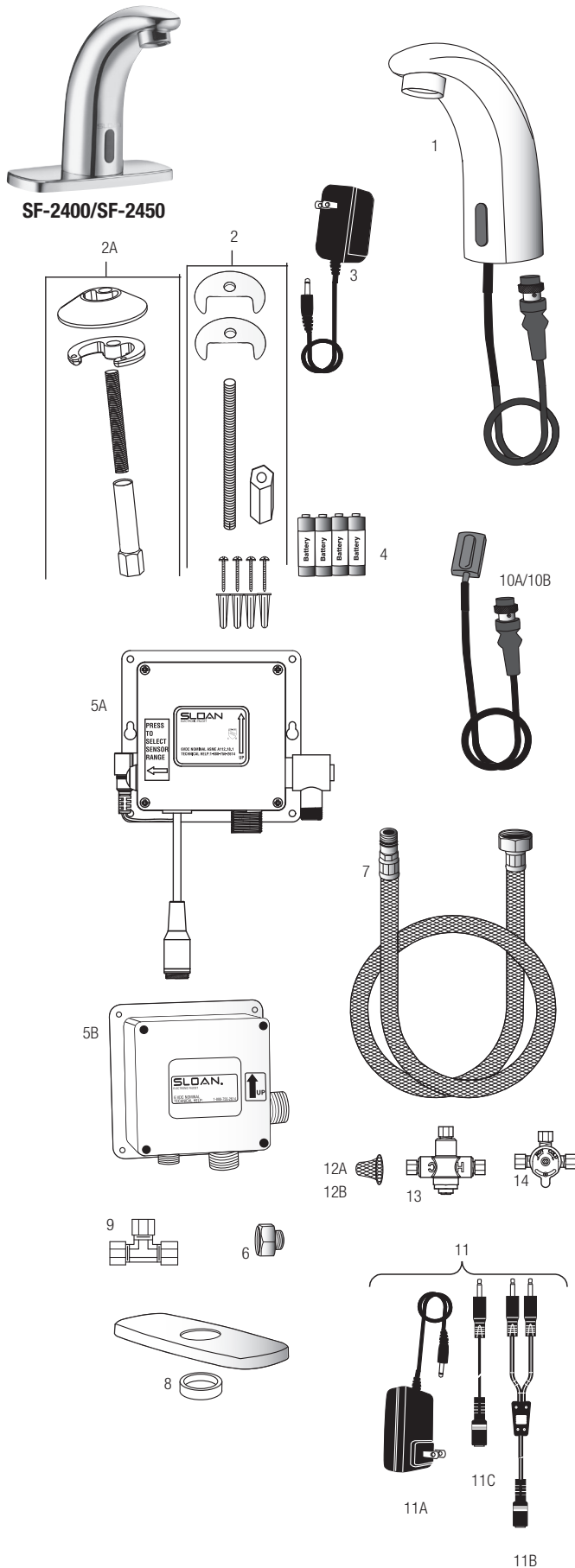

PARTS LIST—SF-2400/SF-2450

Item No.	Code No.	Part No.	Description
1.	—	—	Pedestal Faucet Assembly w/Outlet (Models SF-2400/SF-2450/
2.	0362004	SFP-4	Mounting Hardware Kit, (Models SF-2100/SF-2150/ SF-2400/SF-2450) (pre-3/2010)
2A.	—	SFP-44-A	Mounting Hardware Kit, (Models SF-2100/SF-2150/ SF-2400/SF-2450) (Post 3/2010)
	—	SFP-5	Screws and Anchors for Control Module
3.	0362006	SFP-6	110 VAC/6 VDC Plug-In Adapter (US)
4.	—	—	Batteries-AA size (4)
5A.	0362040	SFP-40-A	Control Module with Adjustable Button (6 pin connector)
5B.	0362008	SFP-8	Control Module (Old Style 4 pin connector)*
6.	0362045	SFP-45-A	Inlet adapter – 1/2" NPSM to 3/8" Compression Connection (not supplied with most international models)
7.	0362010	SFP-10	Flex Hose, Control Module to Spout
8.	0362011	SFP-11	Trim Plate w/ Spacer (not supplied with most international models)
9.	3365461	ETF-617-A	3/8" Bak-Chek® Tee Compression Fitting
10A.	0362041	SFP-41-A	Sensor Assembly (6 pin connector)
10B.	0362034	SFP-34	Sensor Assembly (Old Style 4 pin connector)*

* IMPORTANT: Sloan added the range adjustment feature in August 2008 for faucets made prior to August 2008 use the following replacement parts: SFP-34 and SFP-8

NOT SHOWN SEPARATELY

—	0335029	EAF-51	0.35 gpm (1.3 Lpm) spray head
—	0335012	EAF-15	0.5 gpm (1.9 Lpm) vandal resistant spray head
—	3362000	SFP-1000	0.35 gpm (1.3 Lpm) vandal resistant spray head
—	0362013	SFP-13	0.5 gpm (1.9 Lpm) Spray head
—	0362023	SFP-23	2.2 gpm (8.3 Lpm) Aerator
—	0362024	SFP-24	2.2 gpm (8.3 Lpm) vandal resistant aerator
—	0362020	SFP-26	220 VAC/6 VDC Plug-In Adapter (ASIA)
—	0362025	SFP-25	220 VAC/6 VDC Plug-In Adapter (EURO)
—	0362026	SFP-20	220 VAC/6 VDC Plug-In Adapter (UK)
—	3362022	SFP-22	8" Trim Plate

ACCESSORIES

11.	0362035	SFP-35-A	100-240 VAC/6 VDC Gang Adapter Kit, includes 11A, 11B and 11C
11A.	0362016	SFP-36-A	100-240 VAC/6 VDC Plug-In Adapter
11B.	0362018	SFP-38	Cable Splitter, 51"/1300 mm (5 included in kit)
11C.	0362017	SFP-37	Cable Extension, 51"/1300 mm

REPAIR PARTS

12A.	0362015	SFP-15	Strainer (located in water inlet of control module/for SFP-8 Module)
12B.	3315028	EBF-1004-A	Solenoid Filter Replacement Kit for current solenoid includes Filter Screen Assembly and O-ring
13.	0326045	MIX-135-A	Below Deck Thermostatic Mixing Valve
14.	3326009	MIX-60-A	Below Deck Mechanical Valve Mixing Valve

— in Item No. column = Not shown in illustration
 — in Code No. and Part No. column = Not sold separately

SF-2800/SF-2850 Faucets

TROUBLESHOOTING GUIDE**1. Faucet delivers water in an uncontrolled manner.**

A. Faucet is not working properly. Contact Sloan Technical Support.

2. Faucet DOES NOT deliver any water when Sensor is activated.

INDICATOR: Solenoid valve produces an audible “CLICK.”

A. Water supply stop(s) closed. Open water supply stop(s).

B. Water strainer in control module is clogged. Close supply stops and remove water inlet line at control module. Remove, clean and reinstall strainer and water inlet line. Replace strainer if required.

INDICATOR: Solenoid valve DOES NOT produce an audible “CLICK.”

A. Batteries low (battery powered models). Replace batteries.

B. Power failure (adapter powered models). Check power supply.

3. Faucet delivers only a slow flow or dribble when Sensor is activated.

A. Water supply stop(s) are partially closed. Completely open water supply stop(s).

B. Water strainer in control module is clogged. Close supply stops and remove water inlet line at control module. Remove, clean and reinstall strainer and water inlet line. Replace strainer if required.

C. Aerator is clogged. Remove, clean, and reinstall aerator. Replace aerator if required.

D. Faucet is not working properly. Contact Sloan Technical Support.

4. Faucet DOES NOT stop delivering water or continues to drip after user is no longer detected.

A. Faucet is not working properly. Contact Sloan Technical Support.

5. The water temperature is too hot or too cold on a faucet connected to hot and cold supply lines.

A. Supply Stops are not adjusted properly. Adjust Supply Stops.

CARE AND CLEANING INSTRUCTIONS

DO NOT USE abrasive or chemical cleaners (including chlorine bleach) to clean faucet that may dull the luster and attack the chrome or special decorative finishes. Use **ONLY** mild soap and water, then wipe dry with clean cloth or towel.

While cleaning the bathroom tile, protect the faucet from any splattering of cleaner. Acids and cleaning fluids will discolor or remove chrome plating.

When assistance is required, please contact Sloan Technical Support at: 1-888-SLOAN-14 (1-888-756-2614).

SF-2800/SF-2850 Faucets



SF-2800 Wall Mount, Hardwired
SF-2850 Wall Mount, Battery Powered

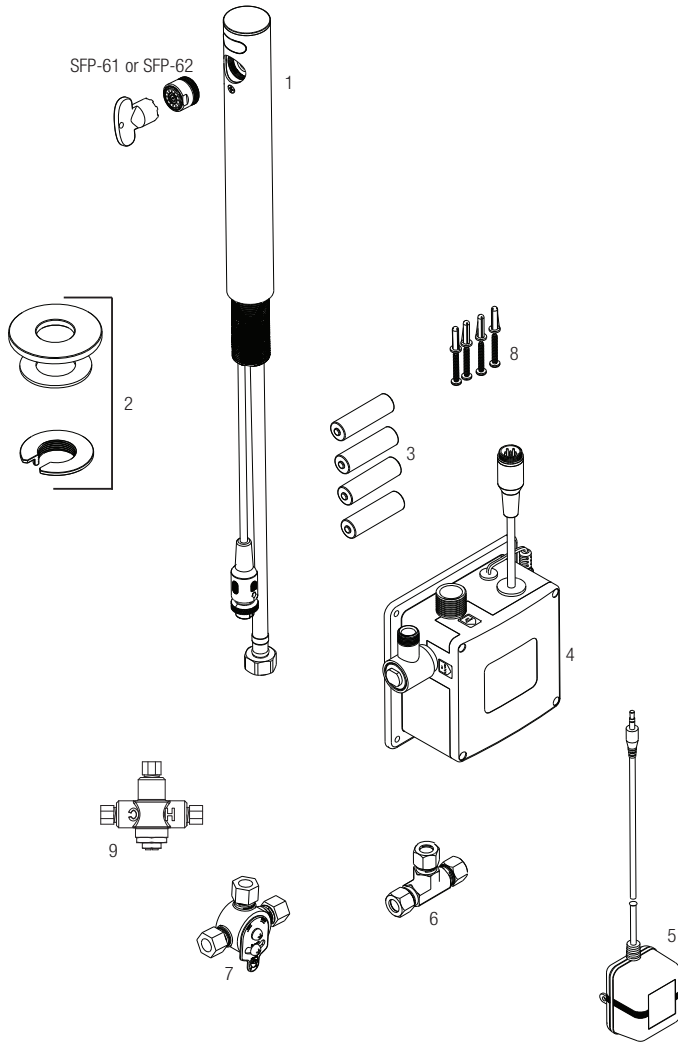

PARTS LIST—SF-2800/SF-2850

Item			
No.	Code No.	Part No.	Description
1.	33621021	SFP-59	Faucet Assembly (Models SF-2800/SF-2850)
2.	33241001	SFP-60	Spout Mounting Hardware Kit w/Trim Plate
3.	_____	_____	Batteries-AA size (4)
4.	0362040	SFP-40-A	Control Module with Adjustable Button (6 pin connector)
5.	0362006	SFP-6	Plug-in Adapter (120VAC/6VDC)
6.	3365461	ETF-617-A	Backcheck Tee
7.	0326007	MIX-60-A	Below Deck Mechanical Mixing Valve
8.	0362005	SFP-5	Control Box Mounting Kit
9.	0326045	MIX-135-A	Below Deck Thermostatic Mixing Valve

SPRAYHEAD OPTIONS

—	33620012	SFP-61	0.35 gpm (1.3 Lpm) Spray Head MLM
—	33620011	SFP-62	0.5 gpm (1.9 Lpm) Spray Head MLM

— in Item No. column = Not shown in illustration

NOTE: Some parts and accessories must be ordered separately * Not shown
 — in Code No. and Part No. column = Not sold separately

SF-2900/SF-2950 Faucets

TROUBLESHOOTING GUIDE

1. Faucet delivers water in an uncontrolled manner.

A. Faucet is not working properly. Contact Sloan Technical Support.

2. Faucet DOES NOT deliver any water when Sensor is activated.

INDICATOR: Solenoid valve produces an audible “CLICK.”

A. Water supply stop(s) closed. Open water supply stop(s).

B. Water strainer in control module is clogged. Close supply stops and remove water inlet line at control module. Remove, clean and reinstall strainer and water inlet line. Replace strainer if required.

INDICATOR: Solenoid valve DOES NOT produce an audible “CLICK.”

A. Batteries low (battery powered models). Replace batteries.

B. Power failure (adapter powered models). Check power supply.

3. Faucet delivers only a slow flow or dribble when Sensor is activated.

A. Water supply stop(s) are partially closed. Completely open water supply stop(s).

B. Water strainer in control module is clogged. Close supply stops and remove water inlet line at control module. Remove, clean and reinstall strainer and water inlet line. Replace strainer if required.

C. Aerator is clogged. Remove, clean, and reinstall aerator. Replace aerator if required.

D. Faucet is not working properly. Contact Sloan Technical Support.

4. Faucet DOES NOT stop delivering water or continues to drip after user is no longer detected.

A. Faucet is not working properly. Contact Sloan Technical Support.

5. The water temperature is too hot or too cold on a faucet connected to hot and cold supply lines.

A. Supply Stops are not adjusted properly. Adjust Supply Stops.

CARE AND CLEANING INSTRUCTIONS

DO NOT USE abrasive or chemical cleaners (including chlorine bleach) to clean faucet that may dull the luster and attack the chrome or special decorative finishes. Use **ONLY** mild soap and water, then wipe dry with clean cloth or towel.

While cleaning the bathroom tile, protect the faucet from any splattering of cleaner. Acids and cleaning fluids will discolor or remove chrome plating.

When assistance is required, please contact Sloan Technical Support at: 1-888-SLOAN-14 (1-888-756-2614).

SF-2900/SF-2950 Faucets



SF-2900 Deck mount, Hardwired

SF-2950 Deck mount, Battery Powered

PARTS LIST—SF-2900/SF-2950

Item No.	Code No.	Part No.	Description
1.	33621021	SFP-63	Faucet Assembly (Models SF-2900/SF-2950)
2.	33620007	SFP-64	Spout Mounting Hardware Kit
3.	_____	_____	Batteries-AA size (4)
4.	0362040	SFP-40-A	Control Module with Adjustable Button (6 pin connector)
5.	0362006	SFP-6	Plug-adaptor (120VAC/6VDC)
6.	3365461	ETF-617	Back Check Tee
7.	0326007	MIX-60A	Below Deck Mechanical Mixing Valve
8.	0362005	SFP-5	Control Box Mounting Kit
9.	0326045	MIX-135-A	Below Deck Thermostatic Mixing Valve

TRIMPLATE OPTIONS

10.	03800004	SFP-65	4" Trimplate with Spacer
-----	-----------------	--------	--------------------------

SPRAYHEAD OPTIONS

—	33620008	SFP-66	0.35 gpm (1.3 Lpm) Spray Head MLM
—	33620009	SFP-62	0.5 gpm (1.9 Lpm) Spray Head MLM

— in Item No. column = Not shown in illustration

NOTE: Some parts and accessories must be ordered separately
 — in Code No. and Part No. column = Not sold separately

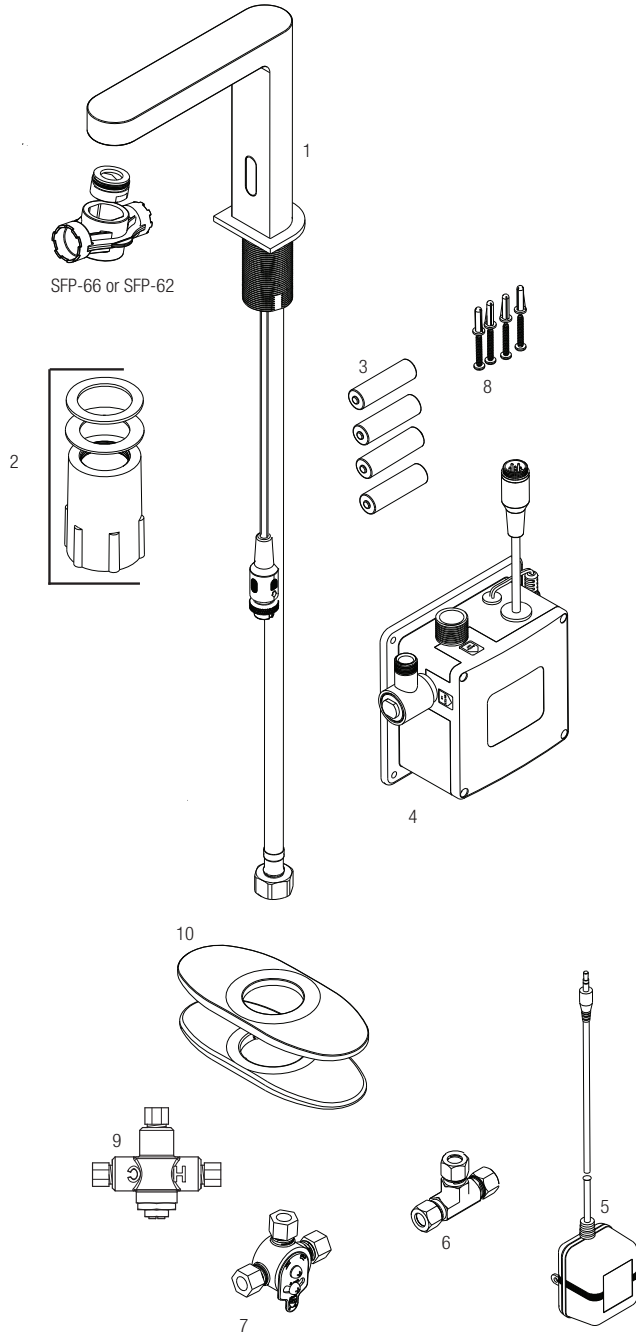

SF-2400/SF-2450 Faucets

TROUBLESHOOTING GUIDE

1. Faucet delivers water in an uncontrolled manner.

A. Faucet is not working properly. Contact Sloan Technical Support.

2. Faucet DOES NOT deliver any water when sensor is activated.

INDICATOR: Solenoid valve produces an audible “CLICK.”

A. Water supply stop(s) closed. Open water supply stop(s).

B. Water strainer in control module is clogged. Close supply stops and remove water inlet line at control module. Remove, clean and reinstall strainer and water inlet line. Replace strainer if required.

INDICATOR: Solenoid valve DOES NOT produce an audible “CLICK.”

A. Batteries low (battery powered models). Replace batteries.

B. Power failure (adapter powered models). Check power supply.

3. Faucet delivers only a slow flow or dribble when sensor is activated.

A. Water supply stop(s) are partially closed. Completely open water supply stop(s).

B. Water strainer in control module is clogged. Close supply stops and remove water inlet line at control module. Remove, clean and reinstall strainer and water inlet line. Replace strainer if required.

C. Aerator is clogged. Remove, clean, and reinstall aerator. Replace aerator if required.

D. Faucet is not working properly. Contact Sloan Technical Support.

4. Faucet DOES NOT stop delivering water or continues to drip after user is no longer detected.

A. Faucet is not working properly. Contact Sloan Technical Support.

5. The water temperature is too hot or too cold on a faucet connected to hot and cold supply lines.

A. Supply Stops are not adjusted properly. Adjust supply stops.

CARE AND CLEANING INSTRUCTIONS

DO NOT USE abrasive or chemical cleaners (including chlorine bleach) to clean faucet that may dull the luster and attack the chrome or special decorative finishes. Use **ONLY** mild soap and water, then wipe dry with clean cloth or towel.

While cleaning the bathroom tile, protect the faucet from any splattering of cleaner. Acids and cleaning fluids will discolor or remove chrome plating.

When assistance is required, please contact Sloan Technical Support at: 1-888-SLOAN-14 (1-888-756-2614).

Optima Plus® ERF- 885 DISCONTINUED



ERF-885

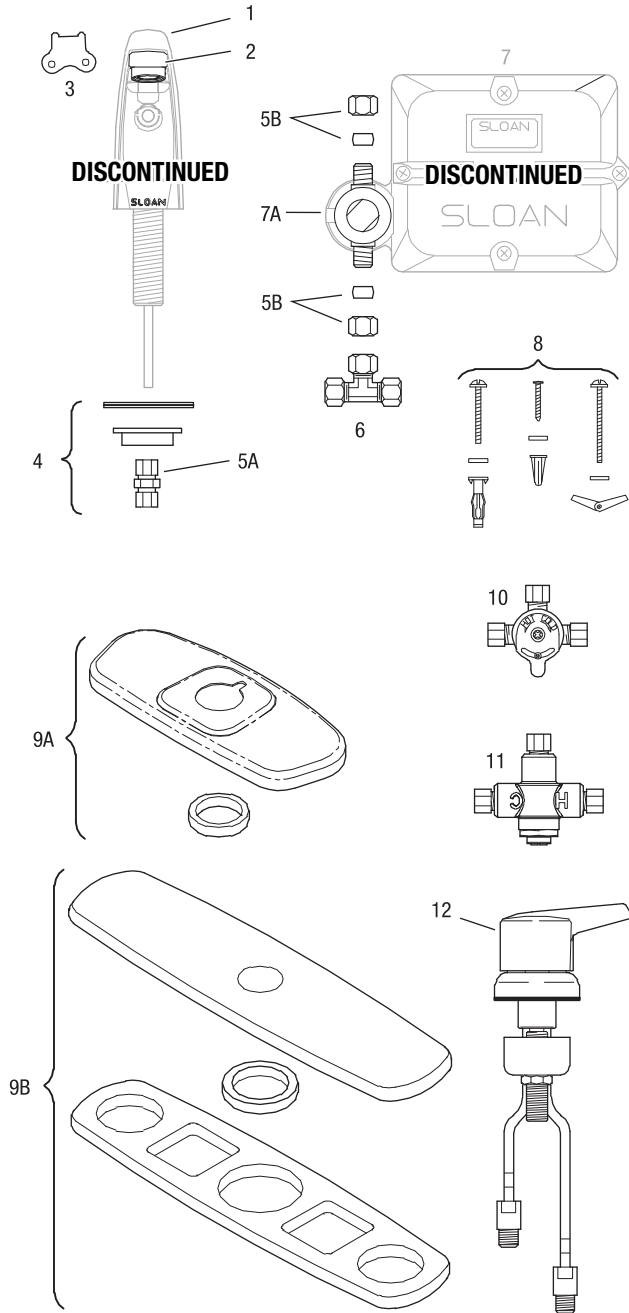

PARTS LIST—EAF-885 FAUCET

Item No.	Code No.	Part No.	Description
1.	0361000	ERF-1-A	Faucet Spout and Sensor Assembly (ERF-885) – DISCONTINUED
2.	3365091	ETF-1021-A	0.5 gpm (1.9 Lpm) Spray Head with Key (male thread)
3.	0305927	ETF-435	Replacement Key Only for ETF-234, 0.5 gpm (1.9 Lpm) Spray Head
4.	0305626	ETF-290-A	Faucet Mounting Kit includes Base Gasket, Flange Nut and ETF-297 Compression Fitting Connector
5A.	0305737	ETF-297	1/4" to 3/8" Tube Compression Fitting Connector
5B.	3315001	EBF-16-A	Single Solenoid Supply Kit includes two (2) Compression Nuts and two (2) Compression Sleeves
6.	3365461	ETF-617-A	3/8" Bak-Chek® Tee Compression Fitting
7.	ERF-2-A	Control Module Assembly	includes Base Enclosure, Cover Enclosure, two (2) Gaskets, Solenoid Body, Solenoid Enclosure and Solenoid Filter Plug – DISCONTINUED
7A.	3315254	EBF-1011-A	Solenoid Replacement Kit includes Solenoid Body, Solenoid Enclosure and Solenoid Filter Plug
8.	3315018	EBF-79-A	Mounting Hardware Kit for Control Module Assembly includes four (4) Anchor Nuts, four (4) Toggle Nuts, four (4) Mounting Screws for Base Plate, four (4) Flat Washers, four (4) Anchors, and four (4) Metal Screws
—	3315028	EBF-1004-A	Solenoid Filter Replacement Kit (not shown) includes Filter Screen Assembly and O-ring
—	0315034	EBF-50	Control Module Replacement Gasket (two required)
TRIM PLATES			
9A.	3365473	ETF-662-A	4" (102 mm) Centerset Single-hole Trim Plate Kit (Standard)
9B.	3365024	ETF-510-A	8" (204 mm) Centerset Single-hole Trim Plate Kit (Optional)
OPTIONAL MIXING VALVES			
10.	3326009	MIX-60-A	Below Deck Mechanical Water Mixing Valve (BDM Variation)
11.	0326045	MIX-135-A	Below Deck Thermostatic Water Mixing Valve (BDT Variation)
12.	3326018	MIX-110-AA	Optimix® Deck Mounted Water Mixing Valve

— = Not shown in illustration

DISCONTINUED FAUCET

Optima Plus® ERF- 885 Faucet Discontinued

TROUBLESHOOTING GUIDE

1. Control module troubleshooting beeper DOES NOT function (no audio “beeps” sound during faucet initialization, battery install or after reset button is pressed).

- A. No battery power is being supplied to control module. Ensure that the batteries are installed properly into the control module. Check that the orientation of each battery matches the positive (+) and negative (-) symbols shown on the bottom of the battery compartment. Reinsert the battery compartment into the control module. Make sure the battery connector is securely attached to the battery compartment. An audio “beep” should sound 6 times.
- B. Insufficient battery power is being supplied to Control module. One (or more) of the batteries is “dead”. To ensure proper operation, insert four (4) new C-size Alkaline batteries. Check that the orientation of each battery matches the positive (+) and negative (-) symbols shown on the bottom of the battery compartment. Reinsert the battery compartment into the control module. Make sure the battery connector is securely attached to the battery compartment. An audio “beep” should sound 6 times.

2. Faucet DOES NOT deliver any water when Sensor is activated.

INDICATOR: Solenoid valve produces audible “CLICK.”

- A. Water supply valve is closed. Open supply stop(s) completely.

INDICATOR: Solenoid valve DOES NOT produce an audible “CLICK.”

- B. Solenoid lead is not properly connected to the control module. Disconnect and reconnect solenoid lead to the control module.
- C. Batteries are not installed properly. Check that the orientation of each battery matches the positive (+) and negative (-) symbols shown on the bottom of the battery compartment. Reinsert the battery compartment into the control module. Make sure the battery connector is securely attached to the battery compartment. An audio “beep” should sound 6 times.

3. Faucet delivers only a slow flow or dribble when sensor is activated.

- A. Water supply valve is partially closed. Open supply stop(s) completely.
- B. Solenoid filter is clogged. Remove, clean, and reinsert. Replace EBF-1004-A solenoid filter kit if necessary.
- C. Aerator or spray head is clogged. Remove, clean, and reinsert.

4. Faucet DOES NOT stop delivering water or continues to drip after user is no longer detected (automatic shut-off fails even when batteries are removed).

- A. Solenoid valve has been connected backwards. Disassemble solenoid valve compression fittings at both the inlet and outlet positions. The water should flow from inlet through the solenoid valve to the outlet according to the direction of the arrow shown on the side of the solenoid valve. Reconnect the compression fittings in the correct orientation.
- B. Solenoid valve is dirty. Backflush by reversing water flow (opposite to the direction shown by the arrow on the side of the solenoid valve) through the solenoid valve. Reconnect the compression fittings in the correct orientation. Activate faucet.
- C. Solenoid valve module is not working properly. Replace solenoid valve module.

5. The water temperature is too hot or too cold on a faucet connected to hot and cold supply lines with Bak-Chek® Tee.

- A. Supply stops are not adjusted properly. Adjust supply stops.

NOTE: For some systems, a thermostatic mixing valve may be required.

CARE AND CLEANING

DO NOT USE abrasive or chemical cleaners (including chlorine bleach) to clean faucets as they may dull the luster and attack the chrome or special decorative finishes. Use **ONLY** soap and water, then wipe dry with clean cloth or towel.

While cleaning the bathroom tile, the faucet should be protected from any splattering of cleaner. Acids and cleaning fluids will discolor or remove chrome plating.

When assistance is required, please contact Sloan Technical Support at: 1-888-SLOAN-14 (1-888-756-2614).

DISCONTINUED FAUCET

Optima® ELF-10/ESF-20/ESF-30 Faucets Discontinued



ELF-10



ESF-20

ESF-30

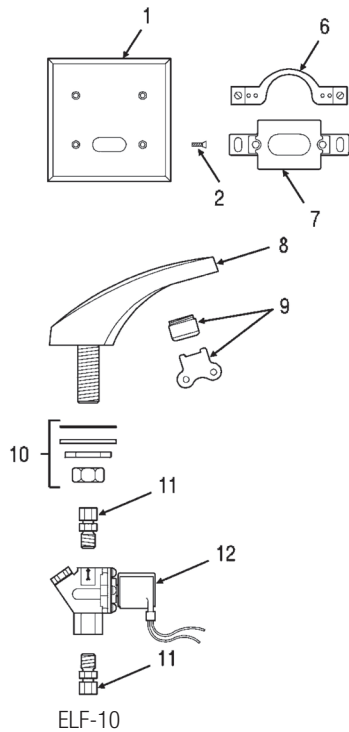

ELF-10

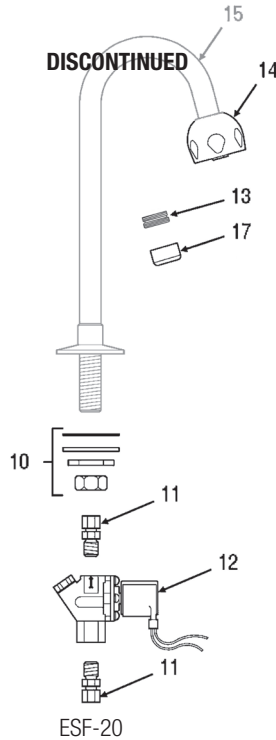

ESF-20

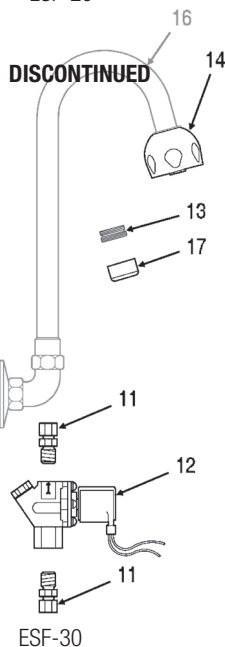
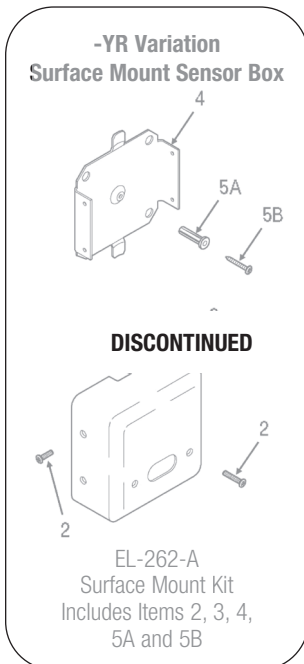

ESF-30

PARTS LIST—ELF-10, ESF-20, AND ESF-30 FAUCETS

Item No.	Code No.	Part No.	Description
1.	0305161	EL-161	Cover Plate for 2-gang junction box (4-1/2" square)
2.	0305152	EL-152	Cover Plate Screws (use 5/64" hex wrench)
3.	0305341	EL-236	Sensor Box (for -YR Variation) – DISCONTINUED
4.	0305345	EL-242	Wall Mounting Bracket Plate (for -YR Variation) – DISCONTINUED
5A.	0311048	K-57	Anchor (for -YR Variation) – DISCONTINUED
5B.	0311041	K-44	Slotted Wood Screw (for -YR Variation) – DISCONTINUED
6.	0305323	EL-168-A	Yoke Assembly includes Yoke, two (2) Screws, and two (2) Washers
7.	3305622	EL-1500-LL	OPTIMA Lavatory Sensor
	3305623	EL-1500-LL-T	OPTIMA Lavatory Sensor with 30-second timeout
8.	0365162	ETF-595-A	Faucet Spout Assembly (ELF-10)
9.	3365092	ETF-1023-A	0.5 gpm (1.9 Lpm) Spray Head with Key (male thread)
	3365093	ETF-1024-A	2.2 gpm (8.3 Lpm) Aerator Spray Head with Key (male thread)
	3365162	ETF-1029-A	2.2 gpm (8.3 Lpm) Laminar Flow Spray Head with Key (male thread)
	0305927	ETF-435	Replacement Key Only
10.	0305768	EL-310-A	Mounting Hardware Kit (ELF-10 and ESF-20 only) includes Washer, Locking Nut, Coupling Nut, Rubber Washer, and Washer Cone
11.	0305459	ETF-61	3/8" Male Compression Fitting x 3/8" NPT
12.	3305527	ETF-1004-A	24 VAC Solenoid Valve Assembly includes male Compression Fitting, Input Power Cable, Solenoid Valve with stainless steel seat, and quick-disconnect Terminal Receptacle
—	3305577	ETF-1009-A	Solenoid Valve Repair Kit includes Replacement Filter
	3375003	MCR-1003-A	Diaphragm only
13.	0305784	ETF-178	Aerator Adapter (ESF-20 and ESF-30 only; not required for Shower Spray Head)
14.	0328134	AC-55-A	Shower Spray Head Assembly, 2.2 gpm (8.3 Lpm)
15.	0328198	AC-92-A	Deck-Mounted Faucet with Gooseneck Spout (ESF-20) – DISCONTINUED
—	0305797	AC-93-A	Deck-Mounted Faucet with Surgical Bend Gooseneck Spout (ESF-20)
16.	0328140	AC-97-A	Back-Mounted Faucet with Gooseneck Spout (ESF-30) – DISCONTINUED
—	0305798	AC-94-A	Back-Mounted Faucet with Surgical Bend Gooseneck Spout (ESF-30) – DISCONTINUED
17.	3365090	ETF-621-A	2.2 gpm (8.3 Lpm) Aerator Spray Head with Key (female thread)
—	0305368	EL-262-A	Surface Mount Kit includes Items 2, 3, 4, 5A, and 5B (for -YR Variation) – DISCONTINUED

Sloan faucets are available in various finishes – contact factory for part numbers.

— = Not shown in illustration

DISCONTINUED FAUCET

Optima® ELF-10/ESF-20/ESF-30 Faucets Discontinued

TROUBLESHOOTING GUIDE

1. Faucet DOES NOT function (RED indicator light does not illuminate when user steps in front of sensor).

- A. No power is supplied to sensor. Ensure that power is turned "ON". Check transformer, leads, and connections. Repair or replace as necessary.
- B. Sensor is not operating. Replace EL-1500-LL or EL-1500-LL-T sensor.

2. Faucet DOES NOT function (RED indicator light appears when user steps in front of sensor BUT solenoid does NOT "CLICK").

- A. Debris is clogging solenoid. Disassemble, clean, flush, and reassemble.
- B. Solenoid electrical wiring is not correctly connected. Check solenoid connections.
- C. Solenoid is not working. Replace ETF-1004-A solenoid.

3. No water is delivered when faucet is activated.

INDICATOR: Solenoid "CLICK" can be heard:

- A. Water supply stop(s) may be partially closed. Open stop(s).
- B. Solenoid filter is clogged. Shut off water supply. Remove, clean, and reinstall solenoid filter. Replace ETF-1009-A solenoid filter if necessary.

4. Very low flow or slow dribble

- A. Water supply stop(s) may be partially closed. Open stop(s).
- B. Solenoid filter is clogged. Shut off water supply. Remove, clean, and reinstall solenoid filter. Replace ETF-1009-A solenoid filter if necessary.
- C. Aerator or spray head is clogged. Remove, clean, and reinstall.
- D. Debris is clogging solenoid. Disassemble, clean, flush, and reassemble.

5. Faucet DOES NOT stop delivering water or continues to drip after user is no longer detected (power is "ON" and RED indicator light is flashing).

- A. Non-permanent target is still detected in range of sensor after user

exits range. Remove non-permanent target. If the target is a new permanent target (i.e., a new wall or partition), turn 24 VAC power supply "OFF" for fifteen (15) seconds. Turn power supply "ON". Allow the sensor to complete the start-up procedure.

- B. Sensor has failed. Replace EL-1500-LL or EL-1500-LL-T sensor.

6. Faucet DOES NOT stop delivering water or continues to drip after user is no longer detected (even after power supply has been disconnected).

- A. Solenoid Valve is installed backward. Disconnect solenoid. Reconnect solenoid so the water flow is directed toward the faucet.
- B. The solenoid is dirty and is not closing properly. Remove solenoid operator, clean, and reassemble.

**When assistance is required, please contact
Sloan Technical Support at: 1-888-SLOAN-14 (1-888-756-2614).**

DISCONTINUED FAUCET

Trim Plates

Description

Sloan offers a variety of Trim Plate Kits for use with OPTIMA® and OPTIMA Plus® Faucets

Specifications

Trim Plates are Chrome Plated Brass and are available for both 4" (102 mm) and 8" (203 mm) Centerset sinks.

8 Inch Trim Plates For 8" (203 mm) Centerset Sink

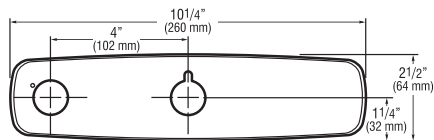

ETF-432-A For use with ETF-660 and ETF-770 faucets

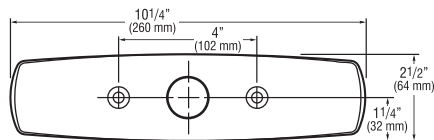

ETF-578-A For use with ETF-600, EBF-650 and EBF-655 faucets

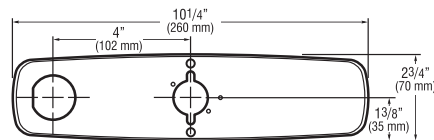

MIX-106-A For use with ETF-610, ETF-700, EBF-615, EBF-625 and EBF-750 faucets with ADM (MIX-110-A-6)

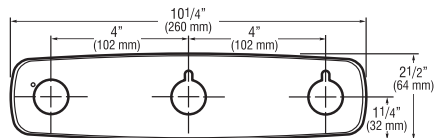

ETF-433-A For use with ETF-660 and ETF-770 faucets with ADM (MIX-110-A-2)

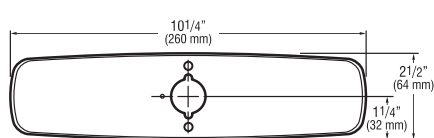

ETF-608-A For use with ETF-610, ETF-700, EBF-615, EBF-625 and EBF-750 faucets

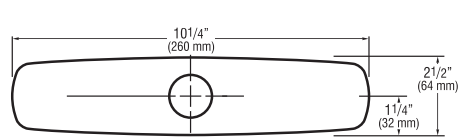

SFP-22 For use with SF-2100/2200/2400, EAF-100, EAF-150 faucets and EAF-350 and EAF-700 Series with 8" centerset

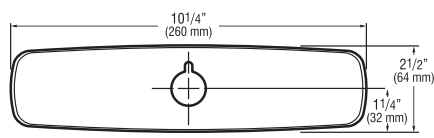

ETF-510-A For use with EAF-200/250/275, ELF-10, ESF-20, ETF-80, ETF-880, EBF-85, EBF-187 and ERF-885 faucets

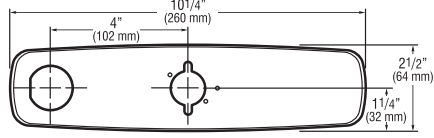

MIX-104-A For use with ELF-10, ESF-20, ETF-80, ETF-880, EBF-85 and EBF-187 faucets with ADM (MIX-110-A-5)

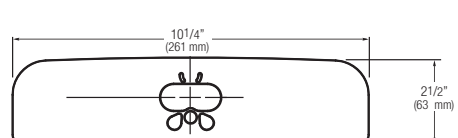

EFX-26-A For use with BASYS EFX-1XX, 2XX, 3XX, 8" baseplate with gasket

4 Inch Trim Plates For 4" (102 mm) Centerset Sink

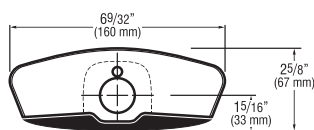

ETF-295-A For use with ETF-80 and EBF-85 faucets

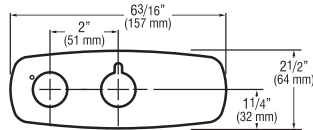

ETF-313-A For use with ETF-660 and ETF-770 faucets

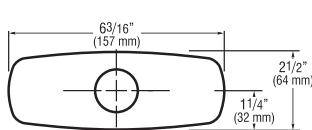

SFP-11 For use with SF-2100/2200/2400 faucets EAF-100, EAF150, 200, EAF-350 and EAF-700 series

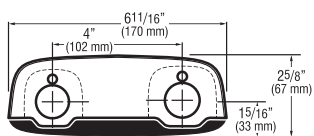

ETF-299-A For use with ETF-80 and EBF-85 faucets with soap/faucet combination

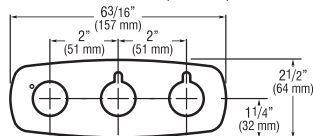

ETF-314-A For use with ETF-660 and ETF-770 faucets with ADM (MIX-110-A-1)

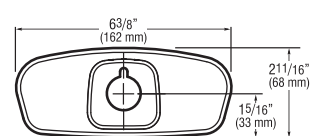

ETF-662-A For use with ETF-880 faucets

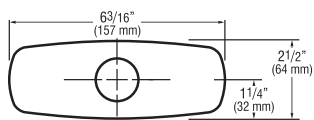

ETF-312-A For use with EAF-200/250/275, ELF-10, ESF-20, ETF-880 and

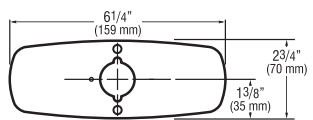

ETF-607-A For use with ETF-610, ETF-700, EBF-625 and EBF-750 faucets

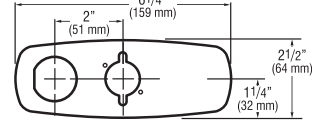

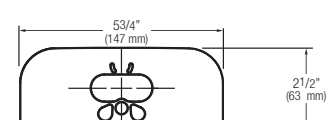

MIX-101-A For use with ELF-10, ESF-20, ETF-80, ETF-880, EBF-85 and EBF-187 faucets









EFX-20-A For use with BASYS EFX-1XX, 2XX, 3XX, 4" baseplate with gasket

Faucet Spout End Devices







BASYS EFX-9/EFX-10

Part No.	Code No.	Flow Rate
EFX-1002-A	3324104	0.5 gpm (1.9 Lpm)
Spray Insert Kit w/Key and Hex Key		
EFX-10001-A	3324103	1.5 gpm (5.7 Lpm)
Spray Insert Kit w/Key and Hex Key		
EFX-1000-A	3324102	1.5 gpm (5.7 Lpm)
LAM		

ETF-80/ETF-880/ETF-770 – EBF-85/EBF-187 – SF-2200/SF-2250 (THREAD SIZE 55/64"-27)

Part No.	Code No.	Flow Rate
ETF-839	0365793	0.35 gpm (1.3 Lpm)
Multi-Laminar Female Thread VR w/Key		
ETF-1021-A	3365091	0.5 gpm (1.9 Lpm)
Multi-Laminar Spray Female Thread VR w/Key		
ETF-1022-A	3365090	2.2 gpm (8.3 Lpm)
AER Female Thread VR w/Key		
ETF-1027-A	3365160	2.2 gpm (8.3 Lpm)
LAM Female Thread VR w/Key		
ETF-1028-A	3365161	1.5 gpm (5.6 Lpm)
LAM Female Thread VR w/Key		
ETF-1038-A	3365755	0.35 gpm (1.3 Lpm)
Multi-Laminar Female Thread VR w/Key		
SFP-14	0362014	2.2 gpm (8.3 Lpm)
LAM Female Thread		









ETF-600/ETF-610/ETF-660 – EBF-615/EBF-625/EBF-650/EBF-655 – ELF-10 (THREAD SIZE 15/16"-27)

EAF-10	0335008	2.2 gpm (8.3 Lpm)
LAM Male Thread		
ETF-688	0365395	1.5 gpm (5.6 Lpm)
LAM Male Thread VR w/Key		
ETF-1023-A	3365092	0.5 gpm (1.9 Lpm)
Multi-Laminar Spray Male Thread VR w/Key		
ETF-1024-A	3365093	2.2 gpm (8.3 Lpm)
AER Male Thread VR w/Key		
ETF-1029-A	3365162	2.2 gpm (8.3 Lpm)
LAM Male Thread VR w/Key		
ETF-1039-A	3365756	0.35 gpm (1.3 Lpm)
Multi-Laminar Male Thread VR w/Key		

Key: LAM – Laminar
 AER – Aerated
 VR – Vandal Resistant
 JR – Junior

Faucet Spout End Devices



EAF SERIES - SF-2100/SF-2150/SF-2300/SF-2350/SF-2400/SF-2450 (THREAD SIZE M24)

Part No.	Code No.	Flow Rate
EAF-12	0335010	0.5 gpm (1.9 Lpm)
Multi-Laminar Spray Metric Male Thread		
EAF-13	0335011	2.2 gpm (8.3 Lpm)
LAM Metric Male Thread		
EAF-15	0335012	0.5 gpm (1.9 Lpm)
Multi-Laminar Metric Male Thread VR w/Key		
EAF-22	0335021	1.5 gpm (5.6 Lpm)
AER Metric Male Thread		
EAF-51	0335029	0.35 gpm (1.3 Lpm)
Multi-Laminar Metric Male Thread		
SFP-13	0362013	0.5 gpm (1.9 Lpm)
Multi-Laminar Spray Metric Male Thread		
SFP-23	0362023	2.2 gpm (8.3 Lpm)
AER Metric Male Thread		
SFP-24	0362024	2.2 gpm (8.3 Lpm)
AER Metric Male Thread VR w/Key		
SFP-1000	3362000	0.35 gpm (1.3 Lpm)
Multi-Laminar Metric Male Thread VR w/Key		
AER Metric Male Thread	Not Shown	
EAF-63	0335036	0.5 gpm (1.9 Lpm)

SLOANSTONE EW-72000/73000 SERIES (THREAD SIZE 13/16"-27)

Part No.	Code No.	Flow Rate
ETF-1037-A	3365747	1.0 gpm (3.8 Lpm)
Multi-Laminar Spray JR Male Thread VR w/Key		



ETF-500/ETF-700 SERIES – ETF-800 – ESF-20/ESF-30/ESF-40 (THREAD SIZE 3/4"-27)

Part No.	Code No.	Flow Rate
ETF-621	0365147	2.2 gpm (8.3 Lpm)
LAM JR Female Thread		
ETF-687	0365387	1.5 gpm (5.6 Lpm)
LAM JR Female Thread		
ETF-801	0365420	0.5 gpm (1.9 Lpm)
Multi-Laminar Spray JR Female Thread		

INSERT ONLY

ETF-689	0365381	1.5 gpm (5.6 Lpm)
LAM Spray Head Insert		
ETF-843	0365437	0.5 gpm (1.9 Lpm)
Multi-Laminar Spray Head Insert		

VANDAL RESISTANT SPRAY HEAD REMOVAL KEY

Part No.	Code No.
ETF-435	0305927PK
Regular/JR Size VR Removal Key	
ETF-731	0365736
Regular/JR Size VR Removal Key	

Key: LAM – Laminar
AER – Aerated
VR – Vandal Resistant
JR – Junior

Spray Head Chart

ETF-80 ETF-880 ETF-770/EBF-775 EBF-85 EBF-187 SF-2200/SF-2250



ETF1038A CP REPAIR KIT VR W/KEY	MULTI-LAMINAR	0.35 GPM	3365755*	55/64 - 27 FEMALE THREAD
ETF1021A CP REPAIR KIT VR W/KEY	MULTI-LAMINAR	0.5 GPM	3365091*	55/64 - 27 FEMALE THREAD
ETF1041A CP REPAIR KIT VR W/KEY	MULTI-LAMINAR	1.0 GPM	3365557*	55/64 - 27 FEMALE THREAD
ETF1028A CP REPAIR KIT VR W/KEY	LAMINAR	1.5 GPM	3365161*	55/64 - 27 FEMALE THREAD
ETF1027A CP REPAIR KIT VR W/KEY	LAMINAR	2.2 GPM	3365160*	55/64 - 27 FEMALE THREAD
ETF1022A CP REPAIR KIT VR W/KEY	AERATED	2.2 GPM	3365090*	55/64 - 27 FEMALE THREAD
SFP14 CP SPRAY HEAD	LAMINAR	2.2 GPM	0362014*	M22 FEMALE THREAD
SFP48 CP SPRAY HEAD OBSOLETE	LAMINAR	1.5 GPM	0362048	M22 FEMALE THREAD
SFP49 CP SPRAY HEAD	MULTI-LAMINAR	1.0 GPM	0362049	M22 FEMALE THREAD

Asterisk (*) indicates sellable item
VR Vandal Resistant

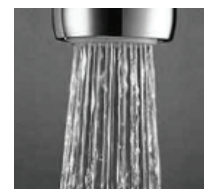

MULTI-LAMINAR FLOW



LAMINAR FLOW



AERATED FLOW

Spray Head Chart

ETF-600/EBF-650	ELF-10	SF-2100	SF-2300	SF-2400 SERIES
-----------------	--------	---------	---------	----------------



ETF1039A CP REPAIR KIT VR W/KEY	MULTI-LAMINAR	0.35 GPM	3365756 *	15/16 MALE THREAD
ETF1023A CP REPAIR KIT VR W/KEY	MULTI-LAMINAR	0.5 GPM	3365092 *	15/16 MALE THREAD
ETF688 CP SPRAY HEAD VR W/KEY	LAMINAR	1.5 GPM	30365395 *	515/16 MALE THREAD
ETF1029A CP REPAIR KIT VR W/KEY	LAMINAR	2.2 GPM	3365162 *	15/16 MALE THREAD
ETF1024A CP REPAIR KIT VR W/KEY	AERATED	2.2 GPM	3365093 *	15/16 MALE THREAD

Asterisk (*) indicates sellable item

VR Vandal Resistant

****SF-2100/2400 series made after 02/2010 use 15/16 male thread****



MULTI-LAMINAR FLOW



LAMINAR FLOW



AERATED FLOW

Spray Head Chart

ETF-500/EBF-550 ETF-700/EBF-750 EBF-850 ESF-20/30/40



ETF839 CP SPRAY HEAD JR	MULTI-LAMINAR	0.35 GPM	0365793*	3/4-27 FEMALE THREAD Spout requires ETF178 adapter on gooseneck
ETF801 CP SPRAY HEAD JR	MULTI-LAMINAR	0.5 GPM	0365420*	3/4-27 FEMALE THREAD Spout requires ETF178 adapter on gooseneck
ETF852 CP SPRAY HEAD JR	MULTI-LAMINAR	1.0 GPM	0365454*	3/4-27 FEMALE THREAD Spout requires ETF178 adapter on gooseneck
ETF687 CP SPRAY HEAD JR	LAMINAR	1.5 GPM	0365387*	3/4-27 FEMALE THREAD Spout requires ETF178 adapter on gooseneck
ETF621 CP SPRAY HEAD JR	LAMINAR	2.2 GPM	0365147*	3/4-27 FEMALE THREAD Spout requires ETF178 adapter on gooseneck



MULTI-LAMINAR FLOW



LAMINAR FLOW



“H” VARIATION for ETF-500/ETF-700-EBF-550-EBF-750

AC-55A SHOWER SPRAY HEAD	AC-55A SHOWER SPRAY HEAD MULTI-LAMINAR	1.5 GPM MAX	0328134*	11/16-24 MALE THREAD Screws directly into spout without ETF178 adapter
--------------------------	---	----------------	----------	--



AERATED FLOW

ETF-EBF 410/415 420/425 810/815 820/825



EFP-120 SPRAY HEAD INSERT W/KEY CACHE TT	MULTI-LAMINAR	0.5 GPM	33620001*	CACHE/HIDDEN/TOM THUMB (TT)
EFP-119 SPRAY HEAD INSERT W/KEY CACHE TT	MULTI-LAMINAR	0.35 GPM	33620002*	CACHE/HIDDEN/TOM THUMB (TT)

Asterisk (*) indicates sellable item
VR Vandal Resistant

CACHE/HIDDEN WITH KEY



Spray Head Chart

EAF-100 Series

EAF- 200 Series

EAF-300 Series



EAF51 CP SPRAY HEAD	MULTI-LAMINAR	0.35 GPM	0335029*	M24 MALE THREAD (regular)
EAF12 CP SPRAY HEAD	MULTI-LAMINAR	0.5 GPM	0335010*	M24 MALE THREAD (regular)
EAF54 CP SPRAY HEAD	LAMINAR	1.0 GPM	0335054*	M24 MALE THREAD (regular)
EAF53 CP SPRAY HEAD	LAMINAR	1.5 GPM	0335053*	M24 MALE THREAD (regular)
EAF13 CP SPRAY HEAD	LAMINAR	2.2 GPM	0335011*	M24 MALE THREAD (regular)
EAF63 CP SPRAY HEAD	AERATED	0.5 GPM	0335036*	M24 MALE THREAD (regular)
EAF22 CP SPRAY HEAD	AERATED	1.5 GPM	0335021*	M24 MALE THREAD (regular)
EAF10 CP SPRAY HEAD	AERATED	2.2 GPM	0335008*	M24 MALE THREAD (regular)

EAF FAUCETS MADE AFTER JAN 2011 WILL NOT ACCEPT "VR" SPRAY HEADS



MULTI-LAMINAR FLOW



LAMINAR FLOW



AERATED FLOW

SF FAUCETS- SF-2100/2300/2400 SERIES



SFP1000 CP SPRAY HEAD VR W/KEY (CURRENT SF FAUCETS)	MULTI-LAMINAR	0.35 GPM	3362000*	15/16" MALE MALE THREAD *WILL FIT M24* REGULAR M24 PRIOR TO 03/2010
SFP46 CP SPRAY HEAD VR W/KEY (CURRENT SF FAUCETS)	MULTI-LAMINAR	0.5 GPM	0362046*	15/16" MALE MALE THREAD *WILL FIT M24* REGULAR M24 PRIOR TO 03/2010
SFP13 CP SPRAY HEAD (FITS SF21/2400 Prior to 03/2010)	MULTI-LAMINAR	0.5 GPM	0362013*	15/16" MALE MALE THREAD *WILL FIT M24* REGULAR M24 PRIOR TO 03/2010
SFP23 CP SPRAY HEAD (FITS SF21/2400 Prior to 03/2010)	AERATED	2.2 GPM	0362023*	15/16" MALE MALE THREAD *WILL FIT M24* REGULAR M24 PRIOR TO 03/2010 (METRIC)
SFP24 CP SPRAY HEAD VR W/KEY (FITS SF21/2400 Prior to 03/2010)	AERATED	2.2 GPM	0362024*	15/16" MALE MALE THREAD *WILL FIT M24* REGULAR M24 PRIOR TO 03/2010

Asterisk (*) indicates sellable item

VR Vandal Resistant

SF FAUCETS- SF-2800/2850 SERIES



SFP61 CP SPRAY HEAD	MULTI-LAMINAR	0.35 GPM	33620012*	CACHE/HIDDEN W/ COLLAR & KEY TOM THUMB (TT)
SFP62 CP SPRAY HEAD	MULTI-LAMINAR	0.5 GPM	33620013*	CACHE/HIDDEN W/ COLLAR & KEY TOM THUMB (TT)



MULTI-LAMINAR FLOW

SF FAUCETS- SF-2900/2950 SERIES



SFP66 CP SPRAY HEAD	MULTI-LAMINAR	0.35 GPM	33620008*	15/16" MALE MALE THREAD REGULAR *WILL FIT M24*
SFP67 CP SPRAY HEAD	MULTI-LAMINAR	0.5 GPM	33620009*	15/16" MALE MALE THREAD REGULAR *WILL FIT M24*



LAMINAR FLOW

For More Sprayhead Options, See EAF-100, 200, 300 Series Chart

Asterisk (*) indicates sellable item

VR Vandal Resistant



AERATED FLOW

EAF 700 SERIES GOOSENECK



EAF1014A HIDDEN SPRAY HEAD W/KEY	MULTI-LAMINAR	0.5 GPM	3335086*	CACHE/HIDDEN TINY JUNIOR (TJ)
EAF1015A HIDDEN SPRAY HEAD W/KEY	AERATED	1.5 GPM	3335087*	CACHE/HIDDEN TINY JUNIOR (TJ)
EAF1016A HIDDEN SPRAY HEAD W/KEY	MULTI-LAMINAR	1.5 GPM	3335088*	CACHE/HIDDEN TINY JUNIOR (TJ)
EAF1023A HIDDEN SPRAY HEAD W/KEY	LAMINAR	1.0 GPM	3335073*	CACHE/HIDDEN TINY JUNIOR (TJ)
EAF1024A HIDDEN SPRAY HEAD W/KEY	MULTI-LAMINAR	0.35 GPM	3335074*	CACHE/HIDDEN TINY JUNIOR (TJ)

EAF59 HIDDEN SPRAY HEAD REMOVAL KEY (FOR EAF&)) SERIES) 0335035*

Spray Head Chart

SLOANSTONE EW 42/430000 EW 60000 SERIES EW 70000 SERIES



ETF1040A CP SPRAY HEAD VR JR W/KEY	MULTI-LAMINAR	0.35 GPM	3365757*	13/16 MALE THREAD
ETF1037A CP SPRAY HEAD VR JR W/KEY	MULTI-LAMINAR	0.5 GPM	3365747*	13/16 MALE THREAD
ETF842A CP SPRAY HEAD VR JR W/KEY (ETF1040A)	MULTI-LAMINAR	0.35 GPM	0365435*	13/16 MALE THREAD
ETF723A CP SPRAY HEAD VR JR W/KEY (ETF1037A)	MULTI-LAMINAR	0.5 GPM	0365735*	13/16 MALE THREAD



MULTI-LAMINAR FLOW

BASYS



LAMINAR FLOW

EFX1000A SPRAY HEAD INSERT KIT W/KEY & 2.5 mm WRENCH	LAMINAR	1.5 GPM	3324102*	RECTANGULAR
EFX1001A SPRAY HEAD INSERT KIT W/KEY & 2mm WRENCH	AERATED	1.5 GPM	3324103*	RECTANGULAR
EFX1002A SPRAY HEAD INSERT KIT W/KEY & 2.5 mm WRENCH	MULTI-LAMINAR	0.5 GPM	3324104*	RECTANGULAR



AERATED FLOW

ETF12A BASYS SPRAY HEAD REMOVAL KEY KIT (BAG OF 5) 3324130*

INSERTS ONLY

ETF689 SPRAY HEAD INSERT	LAMINAR	1.5 GPM	0365381*	REGULAR SIZE WILL FIT ALL NOTED "REGULAR"
ETF731 SPRAY HEAD INSERT	MULTI-LAMINAR	0.5 GPM	0365437*	REGULAR SIZE WILL FIT ALL NOTED "REGULAR"

Asterisk (*) indicates sellable item / VR Vandal Resistant

VANDAL RESISTANT (VR) SPRAY HEAD REMOVAL KEYS

ETF435 REGULAR SIZE VR REMOVAL KEY IF UNAVAILABLE USE ETF-731)	0305927PK*
ETF731 REGULAR AND JUNIOR SIZE VR REMOVAL KEY	0365736*

FOR VR SPRAYHEADS CACHE HIDDEN KEYS CACHE/HIDDEN, KEY & COLLAR

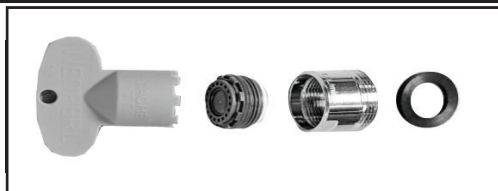
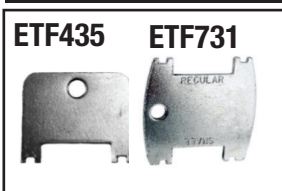

TOP COLOR REPRESENTS GALLONS PER MINUTE (GPM)
 0.35 GPM-Brown
 0.5 GPM-Light Green
 1.0 GPM-Blue
 1.5 GPM-Green or Orange
 2.2 GPM - Yellow

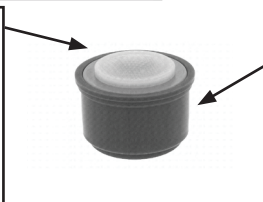

LOWER GRAY BODY COLOR REPRESENTS LAMINAR OR AERATOR
 Light Gray-Laminar Flow
 Dark Gray-Aerated Flow

Water Closets

Wall Hung Water Closets

ST-2000 WALL HUNG SERIES

Item No.	Code No.	Part No.	Description
1.	2102059	ST-2059-A	Top Spud 1.1 to 1.6 gpf (4.2 to 6.0 Lpf) Universal Wall Hung Closet - Discontinued
2.	2102060	ST-2060-A	HET Rear Spud 1.28 gpf (4.8 Lpf) Wall Hung Closet - Discontinued
	2102063	ST-2063-A	Rear Spud 1.6 gpf (6.0 Lpf) Wall Hung Closet
	2112059	ST-2059-A-BPL	Top Spud 1.1 to 1.6 gpf (4.2 Lpf to 6.0 Lpf) Bedpan Lug Universal Wall Hung Closet - Discontinued
3.	2102459	ST-2459	Top Spud 1.1 to 1.6 gpf (4.2 to 6.0 Lpf) Universal Wall Hung Closet
	2112459	ST-2459-BPL	Top Spud 1.1 to 1.6 gpf (4.2 Lpf to 6.0 Lpf) Bedpan Lug Universal Wall Hung Closet
4.	2102469	ST-2469	Rear Spud 1.1 to 1.6 gpf (4.2 to 6.0 Lpf) Universal Wall Hung Closet



Floor Mount Closets

ST-2000 FLOOR MOUNT SERIES

Item No.	Code No.	Part No.	Description
1.	2102009	ST-2009	Top Spud 1.1 to 1.6 gpf (4.2 to 6.0 Lpf)
	2102029	ST-2029	Top Spud 1.6/1.1 gpf (4.2 to 6.0 Lpf) ADA
	2112029	ST-2029BPL	Top Spud 1.6/1.1 gpf (4.2 to 6.0 Lpf) ADA Bedpan Lug Universal Floor Mount Closet
	2102449	ST-2449	Top Spud 1.1 to 1.6 gpf (4.2 to 6.0 Lpf) Universal Floor Mount TAS Closet
2.	2102019	ST-2019	Rear Spud 1.6 gpf (6.0 Lpf) Universal Floor Mount Closet
	2102039	ST-2039	Rear Spud 1.1/1.6 gpf (4.2 to 6.0 Lpf) ADA Universal
3.	2102229	ST-2229	Top Spud 1.1 to 1.6 gpf (4.2 to 6.0 Lpf) ADA Universal Floor Mount Rear Outlet Closet
4.	2102309	ST-2309	Top Spud 1.1 to 1.6 gpf (4.2 to 6.0 Lpf) Universal Junior Toilet
	0319127	ST-27-A	Spud Assembly 1 1/2" - All Closets (not shown)
5.	2112539	ST-2539-LR	Rear Spud 1.28 to 1.6 gpf (4.8 to 6.0 LPF) Universal Floor Mount Rear Outlet Closet



Discontinued

Discontinued



Wall Hung & Floor Mount Water Closets

TROUBLESHOOTING GUIDE

- 1. Water does not shut off in bowl.**
 - A. Contact Sloan Technical Support at 1-888-SLOAN-14 (1-888-756-2614).
 - B. Supply pressure too low. Minimum flowing pressure must be 25 PSI. Adjust supply pressure.
- 2. Water is leaking from toilet.**
 - A. Toilet is not properly mounted. Tighten toilet mount nuts.
 - B. Toilet is not properly mounted. Replace gasket seal.
- 3. Toilet emits odor.**
 - A. Plugged vent line. Remove or clear obstruction in vent line.
- 4. Poor or sluggish flush.**
 - A. Supply pressure too low. Water supply must be able to provide 18 gpm at 25 psi.
 - B. Partially clogged trapway and/or drain pipe and/or vent. Remove or clear obstruction in vent line.
- 5. Incomplete evacuation.**
 - A. Improper Flushometer control stop setting. Close control stop and gradually open until full evacuation is achieved.

IMPORTANT INFORMATION

1. Do not use harsh or caustic chemicals such as drain opening types in this system. These products will damage the vitreous finish.
2. Do not permit foreign objects (i.e., paper towels, paper cups, sanitary napkins, etc.) to be flushed through the toilet.
3. The toilet must be regularly cleaned. See CARE AND CLEANING for details.

CARE AND CLEANING

Sloan's toilets should be cleaned regularly for maximum sanitary and operational performance. As with any plumbing product consistency is important to achieve efficiency and general cleanliness. Before you begin to clean a toilet, gather all the needed materials including personal protection equipment, such as gloves and eyewear.

What You'll Need:

Goggles/safety glasses
Toilet Brush
Gloves
Cleanser for inside the bowl
Cleanser for outside the bowl
Paper towels or cloth

Inside Toilet Bowl:

Add your choice of powder, liquid or gel cleanser to the bowl*. Try to apply the cleaner as close to the toilet rim as possible to prevent diluted cleanser. Begin cleaning the bowl from the top down. Always begin scrubbing under the rim first. Look under the rim to get all the stains and grime scrubbed away. Next scrub the bowl. Finally scrub the drain at the bottom of the bowl. Flush the toilet.

Outside Toilet:

Using a disinfectant/detergent cleaner, mixed either in a spray bottle or in a bucket (according to label instructions), spray or wipe down all the hard surfaces outside of the bowl paying close attention to high touch areas like the toilet seat and flushometer. **NOTE: DO NOT use abrasive or chemical cleaners (including chlorine) to clean flushometers that may dull the luster and attack the chrome or special decorative finishes. Use ONLY mild soap and water, then wipe dry with a clean towel or cloth. If cleaning the fixture with an abrasive or chemical cleaner protect the flushometer from any splattering of cleaner. Acids and cleaning fluids will discolor or remove the finish.** The toilet seat should never be neglected. It is the part of the toilet that comes into actual contact with people, and it needs to be cleaned thoroughly. Raise the seat. Spray the seat, inside lid (if applicable) and the rim of the toilet with cleanser. Wipe down the lid, seat and hinges at the back of the toilet seat.

Wipe Up Spills:

Wipe up any spills that may have splashed or occurred during cleaning.

Service Tip:

Checking for water leaks around toilet fixtures can be difficult to locate the source. Place paper towels around suspected area. It is best to start at the top of the fixture since gravity will cause the water leak to run downward.

When assistance is required, please contact Sloan Technical Support at: 1-888-SLOAN-14 (1-888-756-2614).

*Consult your local janitorial supply to advise best cleansers to use for local water types. Always use cleaners according to their instructions.

Pressure-assisted Toilets

WETS-8000 Series

Model Description	GPF	Handle	Rough-in	Standard Glaze	Sloan TecGlaze
ST-8018 Pressure Assist Tank Assembly	0.75	Left Hand	12"	2108018	-
ST-8016 Pressure Assist Tank Assembly	1.0	Left Hand	12"	2108016	-
ST-8010 Pressure Assist Tank Assembly	1.28	Left Hand	12"	2108010	-
ST-8013 Pressure Assist Tank Assembly	1.6	Left Hand	12"	2108013	-
ST-8118 Pressure Assist Tank Assembly	0.75	Right Hand	12"	2108118	-
ST-8116 Pressure Assist Tank Assembly	1.0	Right Hand	12"	2108116	-
ST-8110 Pressure Assist Tank Assembly	1.28	Right Hand	12"	2108110	-
ST-8113 Pressure Assist Tank Assembly	1.6	Right Hand	12"	2108113	-
ST-8009 Standard Height PA Bowl	0.75 to 1.6	-	12"	2108009	2178009
ST-8029 ADA Height PA Bowl	0.75 to 1.6	-	12"	2108029	2178029

Pressure-assisted Toilets

TROUBLESHOOTING GUIDE

1. Poor Flush.

- A. Check the overall height of the lever in comparison to the frame, and adjust if required.
- B. Make sure water supply valve is fully open.
- C. Flush the supply line to clear any debris and clean inlet screen.
- D. Check bowl (main jet, rim holes and trapway), drain line, and vent for blockage.
- E. Check water pressure supply, operating range is 20-80 PSI (503 Series), 25-80 PSI (504 Series).

2. Pressure vessel takes a long time to fill.

- A. Make sure water supply valve is fully open.
- B. Flush the supply line to clear any debris and clean inlet screen.
- C. Check water pressure supply, operating range is 20-80 PSI (503 Series), 25-80 PSI (504 Series).

3. Noisy pressure vessel water refill.

- A. Flush the supply line to clear any debris and clean inlet screen.
- B. Flush the toilet and hold the handle down for 30 to 40 seconds to flush the system.

4. Water continues to flow through the vessel and will not refill.

- A. Check the overall height of the lever in comparison to the frame, the cable connection to the frame and lever, and adjust if required.
- B. Make sure water supply valve is fully open.
- C. Flush the supply line to clear any debris and clean inlet screen.
- D. Check cartridge and adjust if required.

5. Handle does not activate flush.

- A. Check the cable cassette connection to handle the cable connection to the frame and lever, and adjust if required.
- B. Make sure water supply valve is fully open.
- C. Flush the supply line to clear any debris and clean inlet screen.

6. If the water rises in bowl during the flush and stays there, or drains slowly.

- A. Check bowl (main jet, rim holes and trapway), drain line, and vent for blockage.

7. Leaking tanks.

- A. Check the tank-to-bowl gasket to ensure it is aligned properly and tighten the tank bolts.
- B. Check tank for cracks. If cracked the tank must be replaced.
- C. Check tank bolts. Rubber washers may be corroded or bolts may be loose. Replace or tighten as necessary.

NOTE: be careful not to overtighten nuts on tank as this may result in cracking the tank.

NOTE: It is normal to have some residual water (less than 1") inside the tank.

The vessel is equipped with a drain valve to drain off excess water.

Cleaning & Maintenance

Clean water closet at least once per week with a cleaner safe for vitreous china.

Spray and wipe clean using soft cloth.

Soft abrasive cleaners may be used to remove stains. If you live in a hard water area, you should make certain that the holes under the rim are kept clean and free of mineral build up for proper bowl performance. Use a long-handled brush to clean the rim holes.

Make sure to periodically clean the in-line filter located in the water inlet of the water supply valve.

CAUTION: Do not use any in-tank cleaners or deodorizers. Products containing chlorine (calcium hypochlorite) can seriously damage the Flushmate as well as the fittings in your tank. This damage can cause leakage and property damage. For more complete up-to date information please visit us at www.sloan.com.

If further assistance is required, if you should still have trouble contact Sloan Technical Support at: 1-888- SLOAN-14 (1-888-756-2614)

Gravity Toilets



WETS-4000 Series

Model Description	GPF	Handle	Rough-in	Standard Glaze	Sloan TecGlaze
ST-4010 Gravity Tank Assembly	1.28	Left Hand	12"	2104010	21740092
ST-4011 Gravity Tank Assembly	1.1	Left Hand	12"	2104011	21740093
ST-4013 Gravity Tank Assembly	1.6	Left Hand	12"	2104013	21740094
ST-4110 Gravity Tank Assembly	1.28	Right Hand	12"	2104110	21740095
ST-4111 Gravity Tank Assembly	1.1	Right Hand	12"	2104111	21740096
ST-4113 Gravity Tank Assembly	1.6	Right Hand	12"	2104113	21740097
ST-4210 Gravity Tank Assembly	1.28	Left Hand	10"	2104210	21740098
ST-4211 Gravity Tank Assembly	1.1	Left Hand	10"	2104211	21740099
ST-4213 Gravity Tank Assembly	1.6	Left Hand	10"	2104213	21740100
ST-4310 Gravity Tank Assembly	1.28	Right Hand	10"	2104310	21740101
ST-4311 Gravity Tank Assembly	1.1	Right Hand	10"	2104311	21740102
ST-4313 Gravity Tank Assembly	1.6	Right Hand	10"	2104313	21740103
ST-4009 Standard Height Gravity Bowl	1.1 to 1.6	.	10" or 12"	2104009	2174009
ST-4029 ADA Height Gravity Bowl	1.1 to 1.7	.	10" or 12"	2104029	21740091

Gravity Toilets

TROUBLESHOOTING GUIDE

1. Poor Flush.

- A. Confirm tank is refilling to the water level marked on the refill tube. Adjust as needed.
- B. Check bowl (main jet, rim holes and trapway), drain line, and vent for blockage.

2. Tank takes a long time to fill.

- A. Make sure water supply valve is fully open.
- B. Flush the supply line to clear any debris.
- C. Check water pressure supply, operating range is 5-80 psi.

3. Water continues to run on and will not shut off.

- A. Remove tank lid and confirm the flapper chain is not kinked and has adequate slack to allow flapper to fully seal.
- B. Inspect the rubber seal on the flapper and the top edge of the flush valve to ensure they are clean and free from mineral build-up or debris. Replace flapper if required.

4. Handle does not activate flush.

- A. Remove tank lid and check the flapper chain connection and reattach.
- B. Confirm chain has adequate slack by flushing the toilet. Adjust as needed.

5. Toilet seems to be leaking (water on floor).

- A. Check the tank-to-bowl gasket to ensure it is aligned properly and tighten the tank bolts.
- B. Check tank for cracks. If cracked the tank must be replaced.
- C. Check tank bolts. Rubber washers may be corroded or bolts may be loose. Replace or tighten as necessary.

NOTE: Be careful not to overtighten nuts on tank as this may result in cracking the tank.

- D. Check around the base of the toilet for leaks. If water is coming from underneath the toilet should be removed to inspect the wax gasket and replaced as needed.

CARE AND CLEANING

Clean water closet at least once per week with a cleaner safe for vitreous china. Spray and wipe clean using soft cloth. Soft abrasive cleaners may be used to remove stains.

- If you live in a hard water area, you should make certain that the holes under the rim are kept clean and free of mineral build up for proper bowl performance. Use a long-handled brush to clean the rim holes. Do not use any in-tank cleaners or deodorizers. Products containing chlorine (calcium hypochlorite) can seriously damage your toilet fittings in the tank. This damage can cause leakage and property damage.

Washdown Urinals

STANDARD URINAL SERIES



Item No.	Code No.	Part No.	Description
1. Discontinued	1101000	SU-1000-A	HEU Top Spud 0.125 gpf (0.5 Lpf) Standard Urinal
	1101002	SU-1002-A	HEU Top Spud 0.25 gpf (1.0 Lpf) Standard Urinal
	1101005	SU-1005-A	HEU Top Spud 0.5 gpf (1.9 Lpf) Standard Urinal
	1101006	SU-1006-A	Top Spud 1.0 gpf (3.8 Lpf) Standard Urinal
	1101009	SU-1009	HEU Top Spud 0.125 to 1.0 gpf (0.5 to 1.0 Lpf) Universal Standard Urinal
2. Discontinued	1101010	SU-1010-A	HEU Rear Spud 0.125 gpf (0.5 Lpf) Standard Urinal
	1101012	SU-1012-A	HEU Rear Spud 0.25 gpf (1.0 Lpf) Standard Urinal
	1101015	SU-1015-A	HEU Rear Spud 0.5 gpf (1.9 Lpf) Standard Urinal
	1101016	SU-1016-A	Rear Spud 1.0 gpf (3.8 Lpf) Standard Urinal
	1101019	SU-1019	HEU Rear Spud 0.125 gpf to 1.0 gpf (0.5 Lpf to 3.8 Lpf) Standard Urinal



RETROFIT URINAL SERIES

Item No.	Code No.	Part No.	Description
3. Discontinued	1101200	SU-1200-A	HEU Top Spud 0.125 gpf (0.5 Lpf) Retrofit Urinal
	1101202	SU-1202-A	HEU Top Spud 0.25 gpf (1.0 Lpf) Retrofit Urinal
	1101205	SU-1205-A	HEU Top Spud 0.5 gpf (1.9 Lpf) Retrofit Urinal
	1101209	SU-1209	HEU Top Spud 0.125 to 0.5 gpf (0.5 to 1.9 Lpf) Universal Retrofit Urinal
4. Discontinued	1101210	SU-1210-A	HEU Rear Spud 0.125 gpf (0.5 Lpf) Retrofit Urinal
	1101212	SU-1212-A	HEU Rear Spud 0.25 gpf (1.0 Lpf) Retrofit Urinal
	1101215	SU-1215-A	HEU Rear Spud 0.5 gpf (1.9 Lpf) Retrofit Urinal
	1101219	SU-1219	HEU Rear Spud 0.125 to 0.5 gpf (0.5 to 1.9 Lpf) Universal Retrofit Urinal



SMALL URINAL SERIES

Item No.	Code No.	Part No.	Description
5. Discontinued	1107009	SU-7009	HEU Top Spud 0.125 to 1.0 gpf (0.5 to 3.8 Lpf) Universal Small Urinal
	1107006	SU-7006	Top Spud 1.0 gpf (3.8 Lpf) Small Urinal
6. Discontinued	1107019	SU-7019	HEU Rear Spud 0.125 to 1.0 gpf (0.5 to 3.8 Lpf) Universal Small Urinal
	1107016	SU-7016	Rear Spud 1.0 (3.8 Lpf) Small Urinal
7.	1107409	SU-7409	Top Spud 0.125 to 1.0 gpf (0.5 to 3.8 Lpf) Universal Small Urinal
8.	1107419	SU-7419	HEU Rear Spud 0.125 to 1.0 gpf (0.5 to 3.8 Lpf) Universal Small Urinal

ACCESSORIES

0319147	SU-47-A	Spud Assembly 3/4" - All Urinals (not shown)
0319060	SU-20-A	Small Urinal Mounting Hardware Kit (not shown)
0319105	SU5A	Urinal strainer assembly
0319115	SU13A	Standard urinal mounting hardware kit

Hybrid & Waterfree Urinals

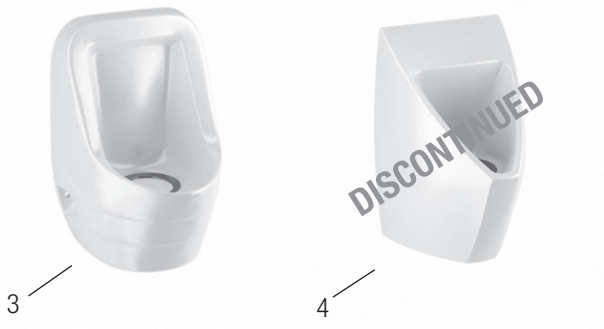

HYBRID URINAL

Item			
No.	Code No.	Part No.	Description
1.	1001020	HYB-1000	Vitreous China Standard Hybrid Urinal (14" x 19 5/8" x 26 3/4")
2.	1001021	HYB-1000 RET	Vitreous China Retrofit Hybrid Urinal (14 3/8" x 16 5/8" x 26 3/4")
3.	1004020	HYB-4000	Vitreous China Hybrid Urinal (14" x 15 3/8" x 22 5/8")
4.	1007020	HYB-7000	Vitreous China Hybrid Urinal DISCONTINUED (14 5/8" x 12 3/4" x 21 7/8")

WATERFREE URINALS

Item			
No.	Code No.	Part No.	Description
5.	1001000	WES-1000	Vitreous China Standard Waterfree Urinal (14 3/8" x 19 5/8" x 26 3/4")
6.	1004000	WES-4000	Vitreous China Small Waterfree Urinal (14" x 15 3/8" x 22 5/8")
7.	1007000	WES-7000	Vitreous China Designer Waterfree Urinal (DISCONTINUED) (14 5/8" x 12 3/4" x 21 7/8")

Hybrid & Waterfree Urinals

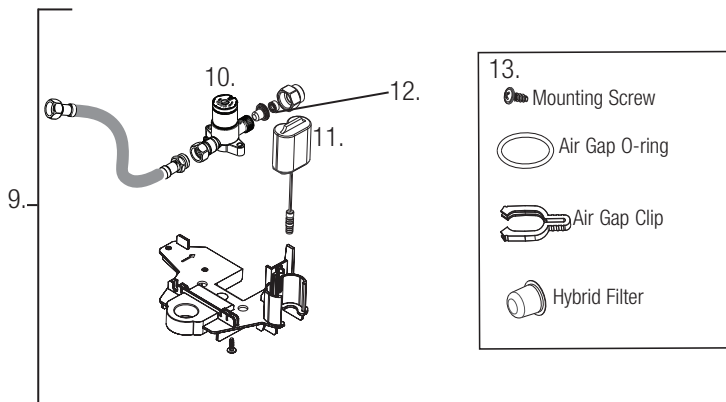
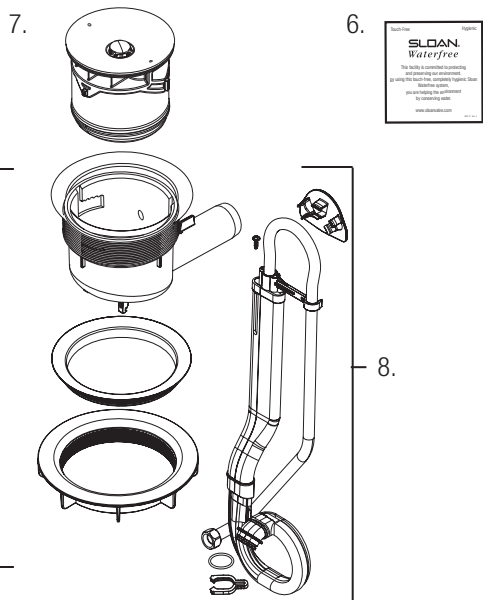
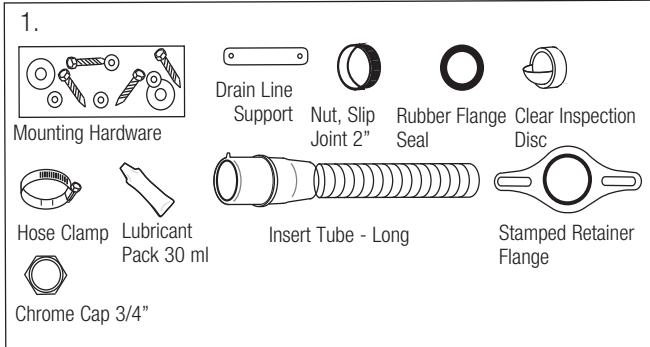
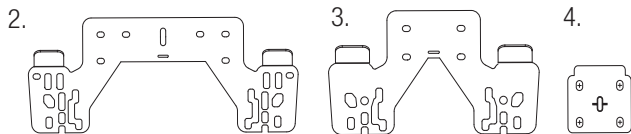

PARTS LIST—

Item			
No.	Code No.	Part No.	Description
1.	1001520	WES-20	Uni-Coupler II - Hardware Kit
2.	0372012	WES-34	Hanger Bracket-WES-1000 & HYB-1000
3.	0372022	WES-36	Hanger Bracket-WES-2000 & HYB-7000
4.	0372032	WES-38	Hanger Bracket-WES & HYB-4000, 5000 & WES-7000
5.	1001510	WES-10	Waterfree Housing Assembly
	0214500	HYB-1-A	Hybrid Housing Assembly
6.	10011521	WES-31	Waterfree Wall Plate
7.	1001500	WES-150	Universal Waterfree Urinal Cartridge
8.	0214502	HYB-3-A	Hybrid Air Gap Assembly
9.	0214501	HYB-2-A	Hybrid Base Plate Assembly
10.	0335001	EHF-2	Hybrid Solenoid
11.	0214504	HYB-5	Hybrid 6V Lithium Battery
12.	0335007	EHF-9	Hybrid Filter
13.	0214503	HYB-4-A	Hybrid Service Kit (Mfg screw, air gap, o-ring & clip)

Not Shown: 1001504 SJS-20 Waterfree Cleaner (cleaner concentrate refill)
 Not Shown: 1001503 SJS-19 Waterfree Starter Kit (32 oz. spray bottle & cleaner concentrate refill)
 Not Shown: 0372001PK WES-1 3/4" water supply inlet cap
 Not Shown: 0372002PK WES-2 1" water supply inlet cap
 Not Shown: 1001502 WES-7 T-Bar Waterfree cartridge removal tool

PRODUCT DESCRIPTION

Sloan Waterfree Urinals use no water which reduces germs and odor. This is because odor-causing germs and bacteria require water to live and to multiply.

Urine contains biosolids.

- For a water flushing urinal a very hard material called calcite forms in the p-trap and drain walls when urine mixes with water. Calcite causes clogs and requires a mechanical auger to remove.
- For a waterfree urinal a soft buttery substance known as struvite forms in urine in the absence of water. Struvite can form in drain lines over time, however, it is water soluble and only requires water to clean.

Sloan utilizes a patented cartridge assembly as the core of its waterfree urinal operation.

HOW IT WORKS

1. The cartridge begins full of liquid with a layer of proprietary biodegradable sealant that floats on the surface.
2. Waste enters the cartridge and passes through this sealant which isolates foul odors from the restroom.
3. Flowing waste is slowed by internal baffles that help retain sealant and allows the uric sediment to settle.
4. Waste flows past an internal trap and exits the cartridge leaving some of the uric sediment behind.
5. The urine accelerates as it is funneled down to a flexible spout where it is redirected out of the housing and into the drain pipe.



Waterfree urinals require regular maintenance to prevent struvite formation from causing drain line blockages-cartridge change & line flushing.

Sloan hybrid urinals offer an automatic drain-rinsing feature that utilizes a controller and solenoid valve to inject water through housing and the lateral drain line.

Hybrid & Waterfree Urinals

OPERATION (Hybrid Urinals Only)

1 AUTOMATIC OPERATION

After waterfree cartridge has been installed and the battery has been connected, the Hybrid Urinal will begin automatically activating about two times per week (every 72 hours from the time the battery is plugged in).

2 MANUAL OPERATION

The Hybrid Urinal should always be manually activated during regular cartridge changes to confirm operation. To do this, wave your hand underneath the urinal within 2 inches to the sensor (see diagram below). You will hear a "CLICK" of the solenoid followed by approximately 10 seconds of rushing water, a three second pause and another 10 seconds of rushing water flowing through the housing and drain line.

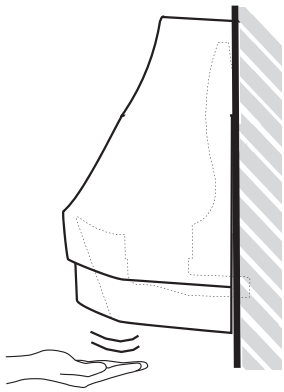

NOTE: After 2 manual activations in a row, there will be a 120 second delay before a third activation can be initiated.

CARTRIDGE REPLACEMENT

The urinal exterior should be cleaned nightly according to the instructions below.

URINAL BOWL CLEANING INSTRUCTIONS

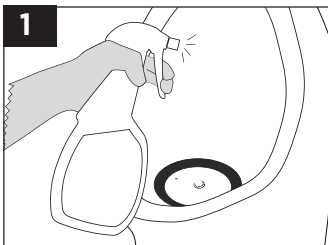

Spray (mist) cleaner on entire bowl.

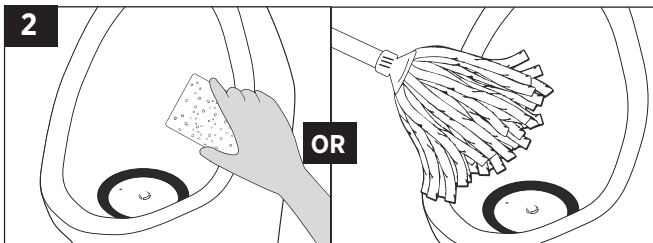

Clean outside and inside of bowl with rag or sponge. Clean outside and inside of bowl with mop.

Hybrid & Waterfree Urinals

CARTRIDGE REPLACEMENT

The cartridge should be changed according to the instructions below:



1 Insert Key into cartridge, turn key to left to unlock.

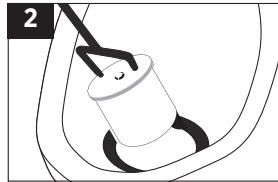

2 Lift and tilt cartridge to drain all free liquids (water, sealant and urine).

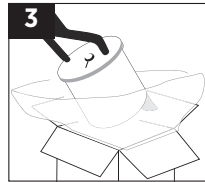

3 Place cartridge into bag, tie bag to seal and dispose.

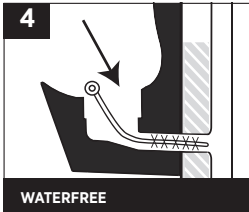

4 Scrub the housing and deep inside of the tail pipe with a long 1.5" diameter nylon brush.

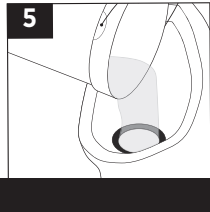

5 Flush housing with 5 gallons (20 Liters) of hot soapy water.

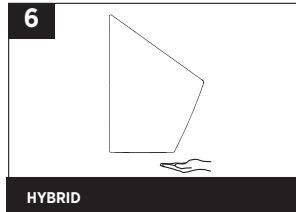

6 Hybrid Urinal Technology should be manually activated each time the cartridge is changed to confirm operation and determine if battery level is sufficient.

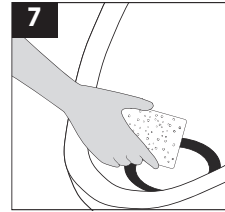

7 Wipe clean inner stainless steel rim.



8 Insert new cartridge into housing and turn key to right to lock and click into place.

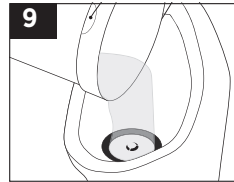

9 Slowly fill cartridge with 1 quart (1 Liter) or more of clean water until there are no more air bubbles.

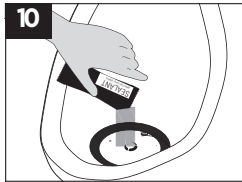

10 Add blue sealant (allow time to drain into cartridge).

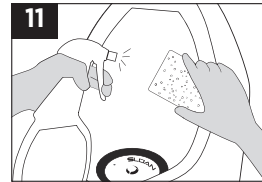

11 Spray (mist) cleaner and wipe clean.

BATTERY REPLACEMENT (Hybrid Urinals Only)

Your battery is a long-lasting lithium and should provide approximately 8 years of operation.

When the battery is low the solenoid will produce an audible chattering sound at the end of activation. This indicates that the battery should be replaced.

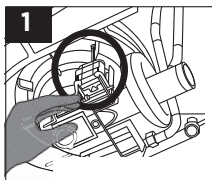

1 Reach underneath the urinal and locate the battery.

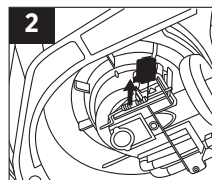

2 Remove the battery from the cradle.

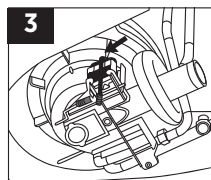

3 Unclip the battery from wire and replace with fresh battery.

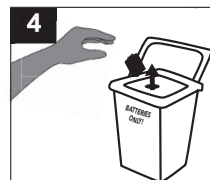

4 Properly dispose of lithium battery according to local codes.

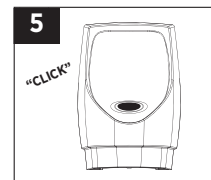

5 After 1 minute the unit will be ready for operation. Swipe hand within 2 inches of sensor and visually inspect that water flows into housing, ensure cartridge is out of housing for inspection.

Hybrid & Waterfree Urinals

TROUBLESHOOTING

1. URINE IS NOT DRAINING OR DRAINING SLOWLY

- Cartridge is full, replace with new cartridge according to instructions inside box.
- Cartridge is not fully locked into place. Sloan logo should be at the 12:00 position when facing the urinal. Use cartridge tool to rotate clockwise until fully seated.
- Improper drain line slope:
 - Tube-in-tube is not installed correctly. Remove urinal from wall and check that arrow tab on black rubber drain tube is at the 12:00 position. Rotate accordingly.
 - Drain line is not pitched correctly. Use standard mending plate to correct drain line pitch. NOTE: Adjustment and re-installation of the urinal hanger bracket may be required to allow the housing drain tail pipe to properly fit into drain line.
 - Housing and/or drain line is clogged. Scrub housing with nylon brush and flush with soapy water according to cartridge replacement instructions.

2. URINE IS ON THE FLOOR/LEAKING

- The hose clamp on the drain is not tightened adequately. Tighten the hose clamp until leak stops.
- Housing is loose. (Hybrid Urinals only) Remove the screw on bottom of electronic board, unclip the electronic board from the bottom of the housing. Lower the electronic board down and out of the way. Unsnap the housing exit tube and use special tool to tighten housing.
- Housing is cracked, urinal bracket is too low placing load onto housing tail pipe inside drain.
 - Raise hanger bracket as necessary to provide concentric insertion of tail pipe into drain line.
 - Replace broken housing.
 - Reinstall urinal according to installation instructions (www.sloan.com).

3. THERE IS A FOUL ODOR COMING FROM THE URINAL

- Cartridge sealant is not present. Dip a rolled up corner of paper towel into the opening at the top of the cartridge. If the paper towel comes out clean or without blue sealant, change the cartridge.
- Odor not coming from urinal. Check other sources of odor such as air vents, toilets, trash receptacles or floor drains. For an extensive list of alternate restroom odor sources please visit www.sloan.com.
- The gear clamp on the drain is not tightened adequately. Tighten clamp.

4. WATER IS ON FLOOR/LEAKING (Hybrid Urinals only)

- Loose supply stop connection. Tighten compression nut on hose.
- Loose 'loop' connection to housing. Check connections and tighten. Lubricate O-Ring at connection.
- Broken air gap assembly. Replace air gap assembly.

5. URINAL DOES NOT DELIVER ANY WATER WHEN SENSOR IS ACTIVATED (Hybrid Urinals only)

INDICATOR: Solenoid valve produces audible "CLICK."

- Water supply stop(s) closed. Ensure water supply stop is open.
- Solenoid strainer clogged. Remove braided hose from solenoid, clean strainer and replace.

INDICATOR: Solenoid valve DOES NOT produce an audible "CLICK."

- Battery low. Replace battery (refer to Battery Replacement section).
- Replace electronic board assembly.

6. URINAL DELIVERS ONLY A SLOW FLOW OR DRIBBLE WHEN SENSOR IS ACTIVATED (Hybrid Urinals only)

- Water supply stop is partially closed. Completely open water supply stop.
- Solenoid strainer is clogged. Remove braided hose from solenoid, clean strainer and replace.

7. URINAL DOES NOT STOP DELIVERING WATER OR CONTINUES TO RUN AFTER ACTIVATION IS COMPLETE (Hybrid Urinals only)

- Urinal is not working properly:
 - Board needs to be reset. Turn off the water at the stop. Unplug battery. Wait 10 seconds and replace battery. Replace battery. After 1 minute unit should cycle properly.
 - If board reset does not work, contact Sloan Technical Support.

Washdown Urinals

TROUBLESHOOTING GUIDE

1. Water DOES NOT shut off in urinal.

- A. Malfunctioning flushometer.
Contact Sloan Technical Support at
1-888-SLOAN-14 (1-888-756-2614).
- B. Supply pressure too low. Minimum flowing pressure must be 25 PSI.
Adjust supply pressure.

2. Water is leaking from edge of urinal on wall.

- A. Urinal is not properly mounted on wall. Tighten urinal mount nuts.
- B. Urinal is not properly mounted on wall. Replace wall gasket seal between wall and urinal.

3. Urinal emits odor.

- A. Plugged vent line. Remove or clear obstruction in vent line.

4. Poor or sluggish flush.

- A. Supply pressure too low. Water supply must be able to provide 18 gpm at 25 psi.
- B. Partially clogged trapway and/or drain pipe and/or vent. Remove or clear obstruction in vent line.

IMPORTANT INFORMATION

1. **DO NOT USE** harsh or caustic chemicals such as drain opening types in this system. These products will damage the vitreous finish.
2. **DO NOT** permit foreign objects (i.e., paper towels, cigarette butts, etc.) to be flushed through the urinal.
3. The urinal must be regularly cleaned. See CARE AND CLEANING for details.

CARE AND CLEANING

Sloan's urinals should be cleaned regularly for maximum sanitary and operational performance. As with any plumbing product consistency is important to achieve efficiency and general cleanliness. Before you begin to clean a urinal, gather all the needed materials including personal protection equipment, such as gloves and eyewear.

What You'll Need:

Goggles/safety glasses
Brush
Gloves
Cleanser for inside the urinal
Cleanser for outside the urinal
Paper towels or cloth
Urinal Screen:

Prior to cleaning, remove urinal screen. After cleaning place screen back in urinal or replace with new screen.

Inside Urinal:

Add your choice of powder, liquid or gel cleanser to the urinal*. Try to apply the cleaner as close to the urinal surface as possible to prevent backsplash. Begin cleaning the urinal from the top down. Always begin scrubbing from the top of the urinal. Look under the rim to get all the stains and grime scrubbed away. Next scrub the urinal. Finally scrub the drain at the bottom of the urinal. Flush the urinal.

Outside Urinal:

Using a disinfectant/detergent cleaner, mixed either in a spray bottle or in a bucket (according to label instructions), spray or wipe down all the hard surfaces outside of the urinal paying close attention to high touch areas like the urinal edge and flushometer. **NOTE: DO NOT use abrasive or chemical cleaners (including chlorine) to clean flushometers that may dull the luster and attack the chrome or special decorative finishes. Use ONLY mild soap and water, then wipe dry with a clean towel or cloth. If cleaning the fixture with an abrasive or chemical cleaner protect the flushometer from any splattering of cleaner. Acids and cleaning fluids will discolor or remove the finish.** The urinal edge rim should never be neglected. It is the part of the urinal that comes into actual contact with people, and it needs to be cleaned thoroughly. Spray inside the urinal and the rim of the urinal with cleanser. Wipe down the urinal.

Wipe Up Spills:

Wipe up any spills that may have splashed or occurred during cleaning.

Service Tip:

Checking for water leaks around toilet fixtures can be difficult to locate the source. Place paper towels around suspected area. It is best to start at the top of the fixture since gravity will cause the water leak to run downward.

When assistance is required, please contact Sloan Technical Support at: 1-888-SLOAN-14 (1-888-756-2614).

*Consult your local janitorial supply to advise best cleansers to use for local water types. Always use cleaners according to their instructions.

Vitreous China Lavatories

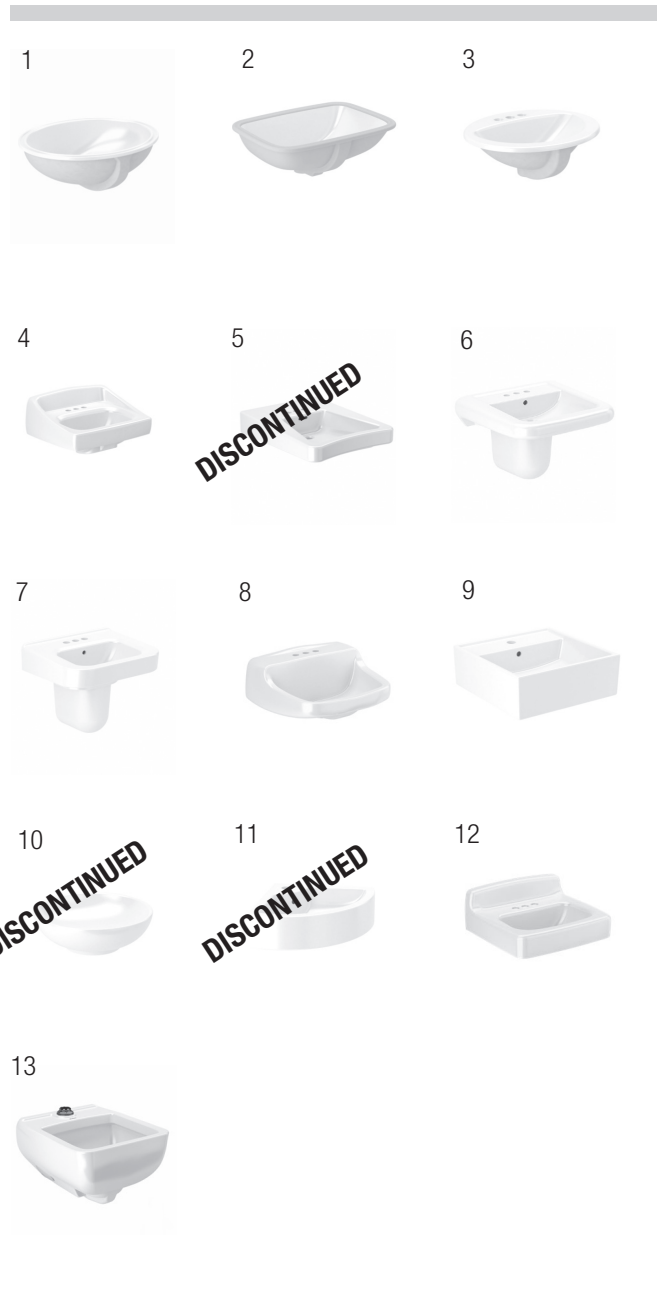

STANDARD UNDERMOUNT LAVATORY

Item No.	Code No.	Part No.	Description
1.	3873001	SS-3001	Oval Undermount Lavatory 19-1/2" x 17-1/2" outside, 17" x 14" Inside dimension
2.	3873021	SS-3021	Rectangular Undermount Lavatory 21-5/8" x 15-3/4" x 8-1/4"

STANDARD DROP IN LAVATORY

3.	3873002	SS-3002	Standard Drop In Lavatory 20" x 16-3/4", 4" centerset
	3823102	SS-3102	Standard Drop In Lavatory 20" x 16-3/4", 1 Hole
	3873802	SS-3802	Standard Drop In Lavatory 20" x 16-3/4", 8" centerset

STANDARD WALL HUNG LAVATORY

4.	3873003	SS-3003	Standard Wall Hung Lavatory 21" x 19-1/4" with 4" Backsplash, 4" centerset
	3873103	SS-3103	Standard Wall Hung Lavatory 21" x 19-1/4" with 4" Backsplash, 1 Hole
	3873803	SS-3803	Standard Wall Hung Lavatory 21" x 19-1/4" with 4" Backsplash, 8" centerset

ADA WHEELCHAIR WALL HUNG LAVATORY

5.	3873004	SS-3004	ADA Wheelchair Wall Hung Lavatory 20" X 27", 4" centerset DISCONTINUED
	3873104	SS-3104	ADA Wheelchair Wall Hung Lavatory 20" X 27", 1 Hole DISCONTINUED
	3873804	SS-3804	ADA Wheelchair Wall Hung Lavatory 20" X 27", 8" centerset DISCONTINUED

ADA LEDGEBACK WALL HUNG LAVATORY (SHROUD OPTIONAL)

6.	3873065	SS-3065	ADA Ledgeback Wall Hung Lavatory 21" x 20", 4" centerset
	3873165	SS-3165	ADA Ledgeback Wall Hung Lavatory 21" x 20", 1 Hole
	3873865	SS-3865	ADA Ledgeback Wall Hung Lavatory 21" x 20", 8" centerset

LEDGEBACK WALL HUNG LAVATORY (SHROUD OPTIONAL)

7.	3873006	SS-3006	Wall Hung Lavatory 20" x 18-1/4", 4" centerset
	3873506	SS-3506	Wall Hung Lavatory RH soap hole 20" x 18-1/4", 4" centerset
	3873406	SS-3406	Wall Hung Lavatory LH soap hole 20" x 18-1/4", 4" centerset
	3873106	SS-3106	Wall Hung Lavatory 20" x 18-1/4", 1 Hole
	3873206	SS-3206	Wall Hung Lavatory LH soap hole 20" x 18-1/4", 1 Hole
	3873306	SS-3306	Wall Hung Lavatory RH soap hole 20" x 18-1/4", 1 Hole
	3873806	SS-3806	Wall Hung Lavatory 20" x 18-1/4", 8" centerset
8.	3873055	SS-3055	Wall Hung Lavatory 19" x 17" 4" Centerset

VESSEL LAVATORY

9.	3873026	SS-3026	Square Vessel Lavatory 18-1/2" x 18-1/2" x 6-3/4" Single Hole
10.	3873036	SS-3036	Round Vessel Lavatory DISCONTINUED 15-3/4" x 5-1/2" Rear Overflow

WALL HUNG CORNER LAVATORY

11.	3873145	SS-3145	Wall Hung Corner Lavatory DISCONTINUED 16-1/2" x 15" x 6" Single Hole
-----	----------------	---------	--

WALL HUNG CAST IRON LAVATORY

12.	3873017	SS-3017	Sink 20" X 18" 4" CENTERSET
	3873117	SS-3117	Sink 20" X 18" SINGLE HOLE

CLINIC SERVICE SINK

13.	3873200	SS-3200	Service Sink Wall Mounted 24 7/8" x 15 7/8" x 21"
-----	----------------	---------	---

CERAMIC SHROUD

0387678	SS-27-A	Ceramic Lavatory Shroud for use with SS-3006 and SS-3065 series lavs only (shown in #6 & #7)
----------------	---------	--

CARE AND CLEANING

Clean lavatory with a cleaner safe for vitreous china. Spray and wipe clean using soft cloth. Soft abrasive cleaners may be used to remove stains.

**AER-DEC® 81000/82000/83000/84000
INTEGRATED SINK SYSTEM**

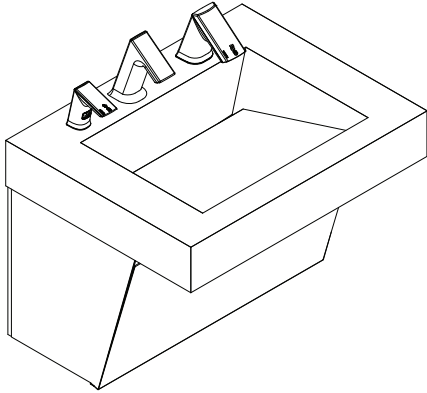

AD-81000
Deck Sink Lavatory System

1 Station Components

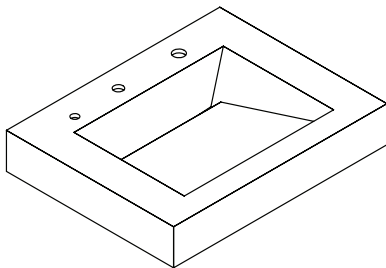

1) AD-81000 Deck

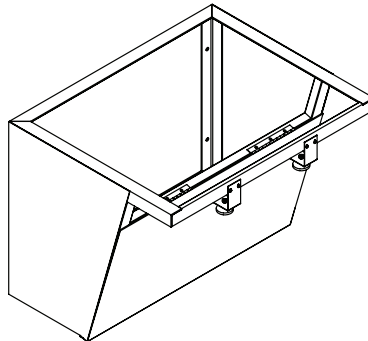

2a) Angled Enclosure

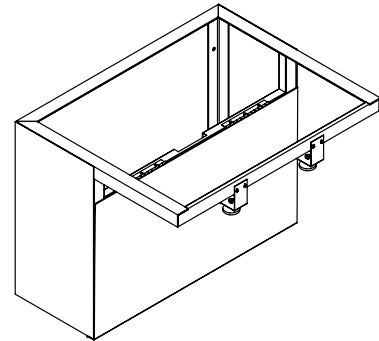

2b) Vertical Enclosure

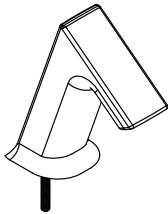

3) EFX Series Faucet

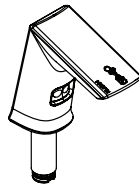

4) ESD 500 Soap Dispenser

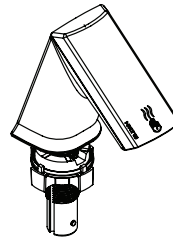

5) Basys Style Hand Dryer

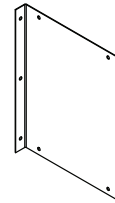

6) Hand Dryer Bracket
(Vertical Enclosure Only)

AER-DEC One Station Component List

Description	Item Number	Quantity
AER-DEC, One Station, Integrated Deck	1	1
Angled Enclosure with Hold Open Door	2a	1
Vertical Enclosure with Hold Open Door	2b	1
EFX Series Faucet	3	1
Basys Style ESD 500 Soap Dispenser	4	1
Basys Style Hand Dryer	5	1
Hand Dryer Bracket	6	1

Note: Hand Dryer Motor must be rotated 90° for installation into a standard vertical enclosure.

AER-DEC® 81000/82000/83000/84000
INTEGRATED SINK SYSTEM

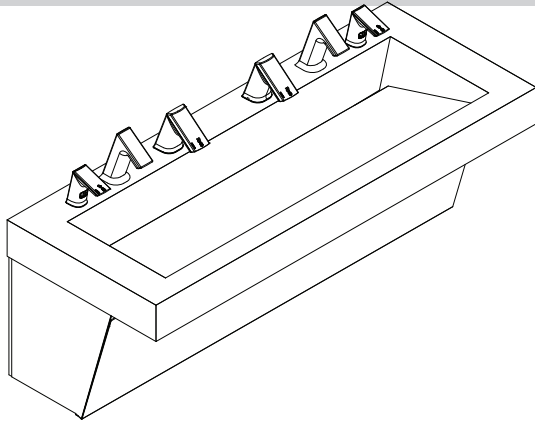

AD-82000
 Deck Sink Lavatory System

2 Station Components

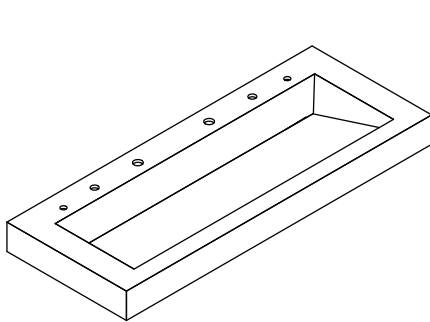

1) AD-82000 Deck

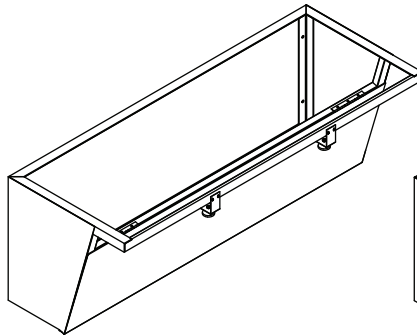

2a) Angled Enclosure

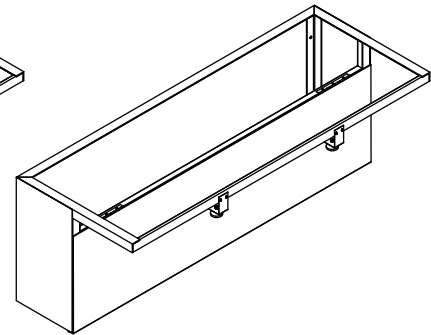

2b) Vertical Enclosure

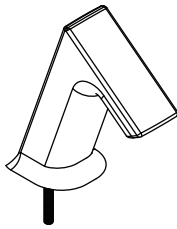

3) EFX Series Faucet

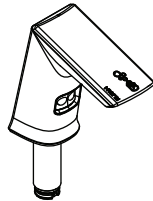

4) ESD 500 Soap Dispenser

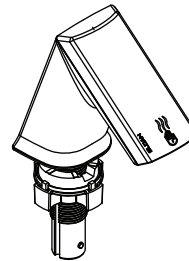

5) Basys Style Hand Dryer

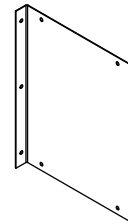

6) Hand Dryer Bracket
 (Vertical Enclosure Only)

AER-DEC Two Station Component List

Description	Item Number	Quantity
AER-DEC, Two Station, Integrated Deck	1	1
Angled Enclosure with Hold Open Door	2a	1
Vertical Enclosure with Hold Open Door	2b	1
EFX Series Faucet	3	2
Basys Style ESD 500 Soap Dispenser	4	2
Basys Style Hand Dryer	5	2
Hand Dryer Bracket	6	2

Note: Hand Dryer Motor must be rotated 90° for installation into a standard vertical enclosure.

AER-DEC® 81000/82000/83000/84000
INTEGRATED SINK SYSTEM

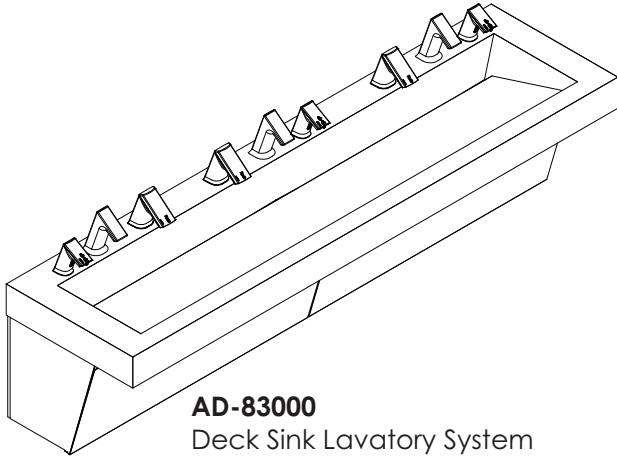

AD-83000
Deck Sink Lavatory System

3 Station Components

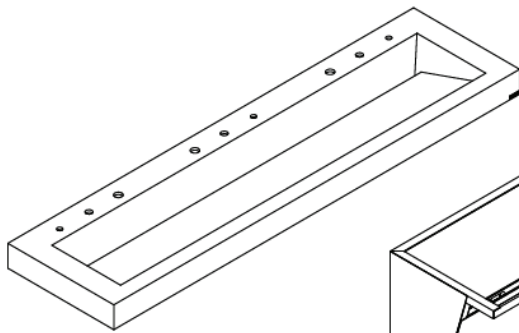

1) AD-83000 Deck

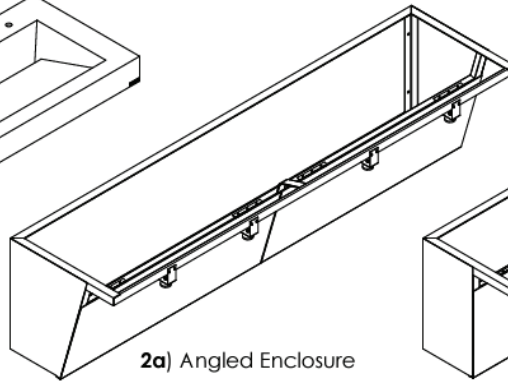

2a) Angled Enclosure

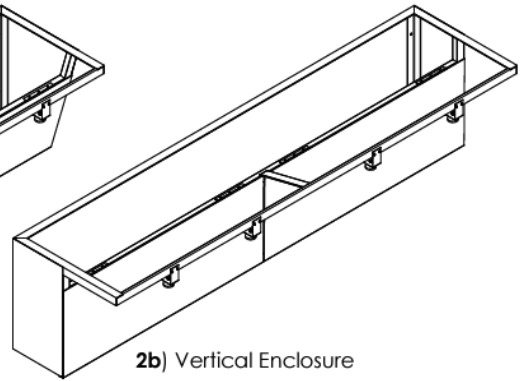

2b) Vertical Enclosure

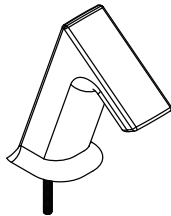

3) EFX Series Faucet

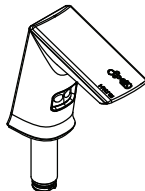

4) ESD 500 Soap Dispenser

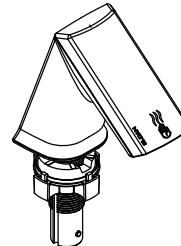

5) Basys Style Hand Dryer

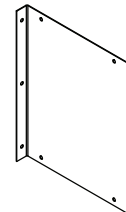

6) Hand Dryer Bracket
(Vertical Enclosure Only)

AER-DEC Two Station Component List

Description	Item Number	Quantity
AER-DEC , Two Station, Integrated Deck	1	1
Angled Enclosure with Hold Open Door	2a	1
Vertical Enclosure with Hold Open Door	2b	1
EFX Series Faucet	3	2
Basys Style ESD 500 Soap Dispenser	4	2
Basys Style Hand Dryer	5	2
Hand Dryer Bracket	6	2

Note: Hand Dryer Motor must be rotated 90° for installation into a standard vertical enclosure.

**AER-DEC® 81000/82000/83000/84000
INTEGRATED SINK SYSTEM**

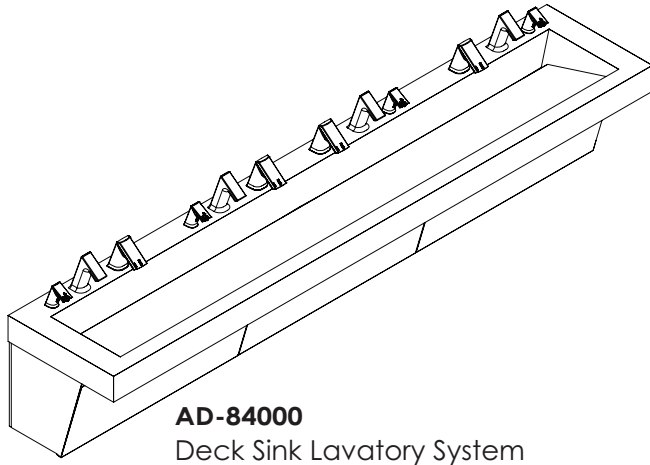

AD-84000
Deck Sink Lavatory System

4 Station Components

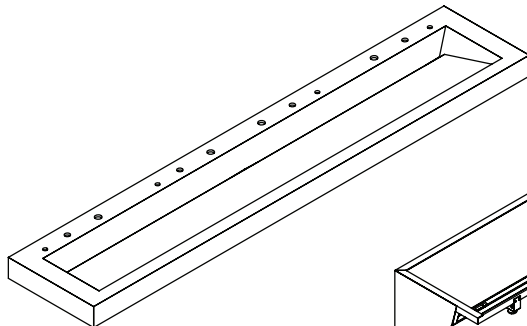

1) AD-83000 Deck

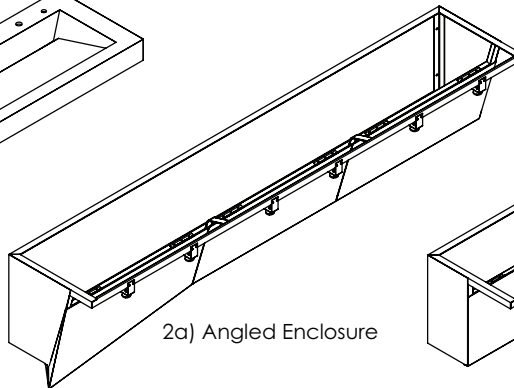

2a) Angled Enclosure

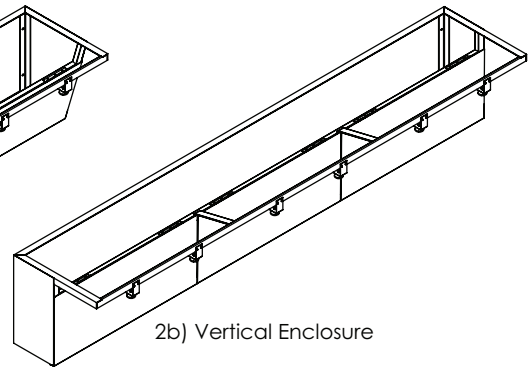

2b) Vertical Enclosure

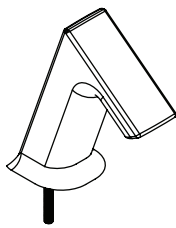

3) EFX Series Faucet

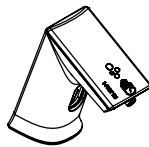

4) ESD 400 Soap Dispenser

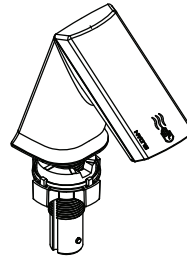

5) Basys Style Hand Dryer

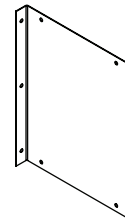

6) Hand Dryer Bracket
(Vertical Enclosure Only)

AER-DEC Four Station Component List		
Description	Item Number	Quantity
AER-DEC, Four Station, Integrated Deck	1	1
Angled Enclosure with Hold Open Door	2a	1
Vertical Enclosure with Hold Open Door	2b	1
EFX Series Faucet	3	4
Basys Style ESD 500 Soap Dispenser	4	4
Basys Style Hand Dryer	5	4
Hand Dryer Bracket	6	4
Note: Hand Dryer Motor must be rotated 90° for installation into a standard vertical enclosure.		

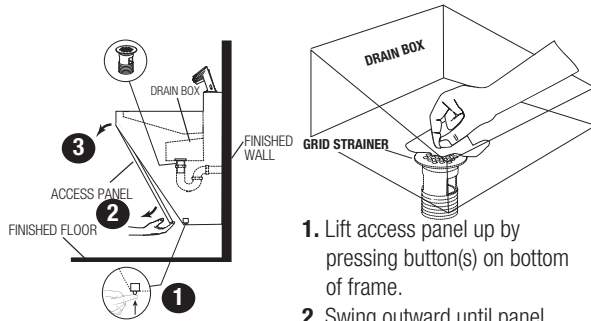
AER-DEC® 81000/82000/83000/84000**INTEGRATED SINK SYSTEM****CLEANING AND MAINTENANCE****REGULAR CLEANING OF DRAIN BOX REQUIRED (if app.)**

1. Lift access panel up by pressing button(s) on bottom of frame.
2. Swing outward until panel separates frame.
3. Lift and separate from frame.
4. Clean the box and the grid strainer with a rag and disinfectant containing bleach and dispose of properly.
5. Close access panel.

SloanStone® ELRF-80000 Sink

1 Station Components

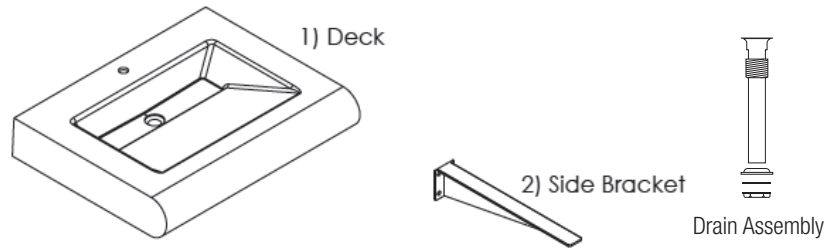

2 Station Components

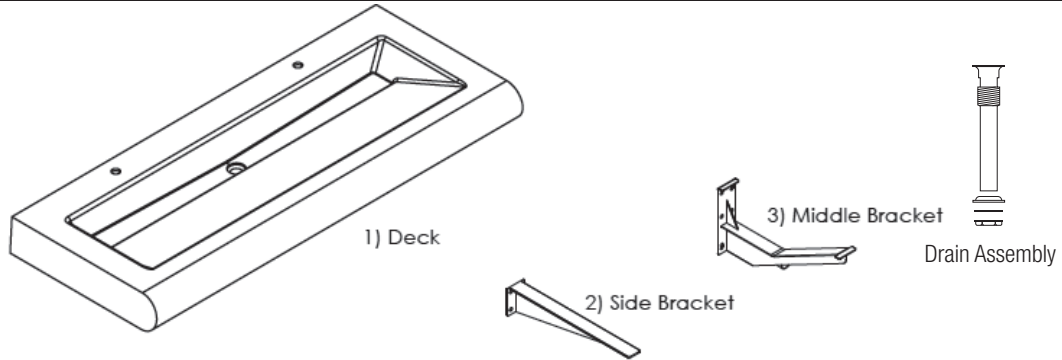

3 Station Components

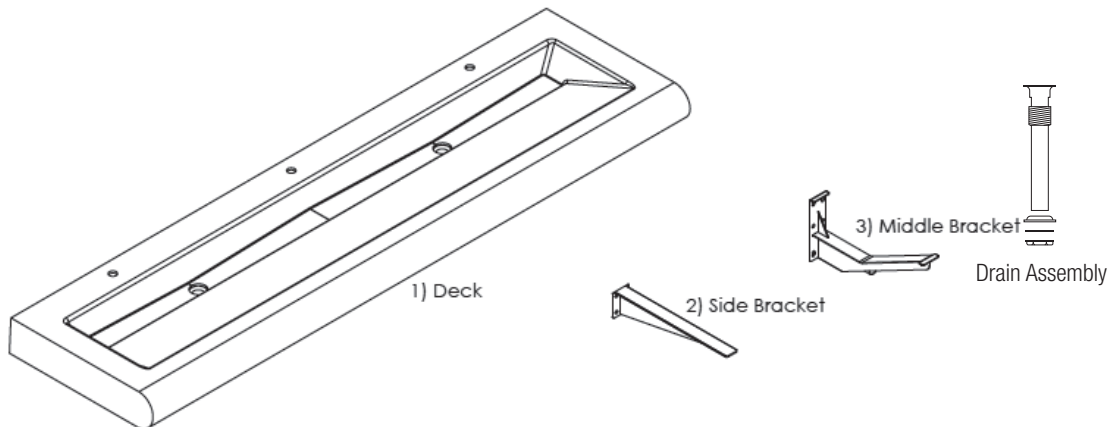

4 Station Components

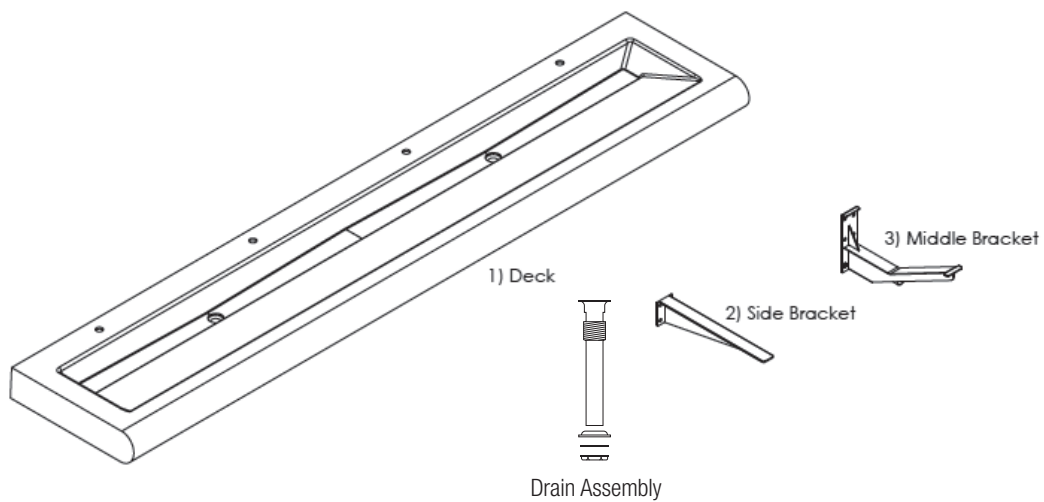

SloanStone® ELRF-80000 Sink

CARE & CLEANING

SloanStone Solid Surface Care

For normal cleaning, use warm, soapy water or conventional ammonia based liquid glass cleaner.

For dry stains, allow the soapy water or glass cleaner some time to remoisturize the area, then wipe the stain off.

To renew the surface after deep scratches or stains, use green, then maroon, and finally white 3M Scotch-Brite® pads to return the deck to a smooth 1200 grit wet-sanded finish.

If the dry stain is neither water-based nor oil-based, gently scrape the stain off with a plastic material (i.e. a plastic knife), and then proceed with the aforementioned normal cleaning procedures.

Wipe the entire surface evenly with a mild abrasive cleanser for regular maintenance.

**When assistance is required, please contact
Sloan Technical Support at: 1-888-SLOAN-14 (1-888-756-2614).**

SloanStone® ELA-80000 Sink

1 Station Components

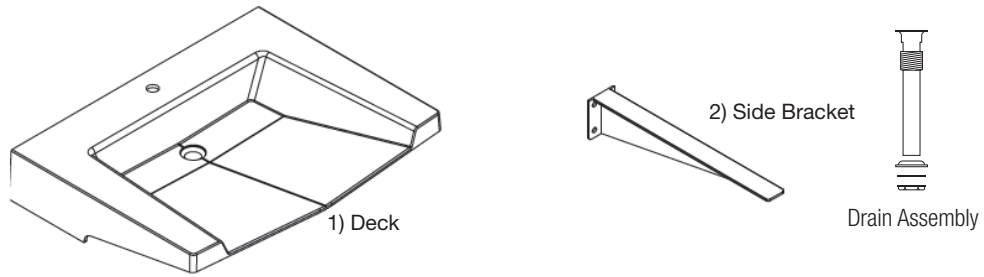

2 Station Components

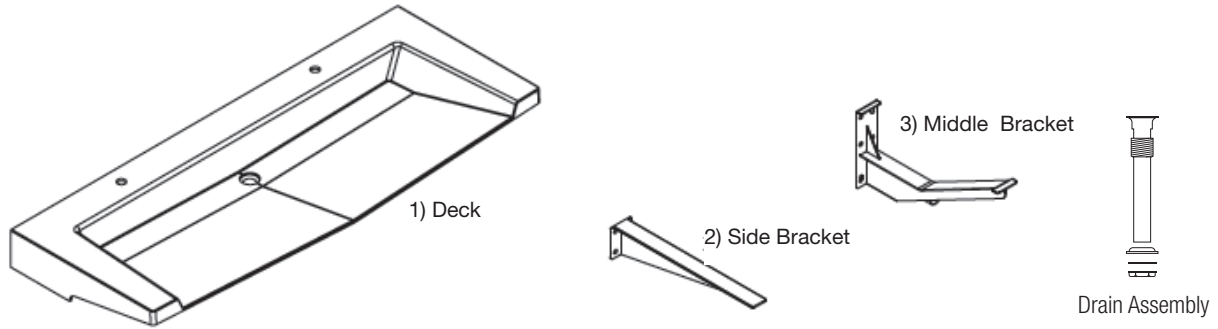

3 Station Components

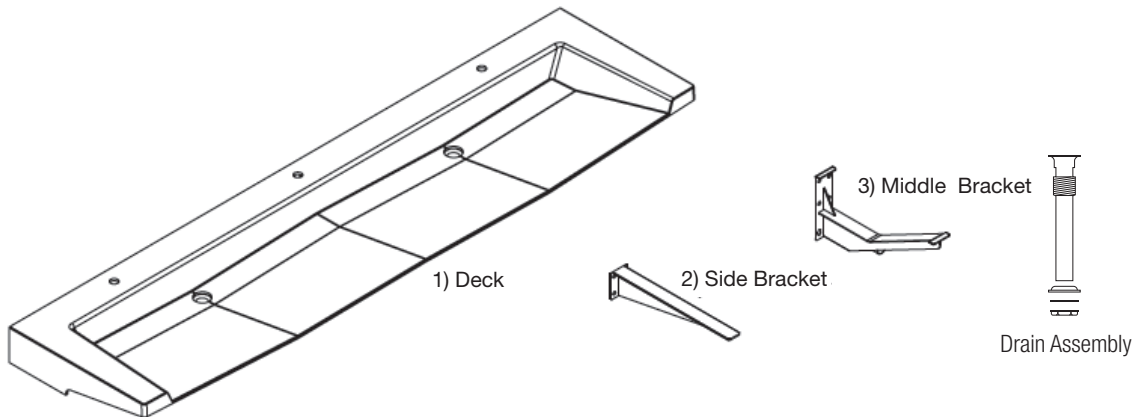

4 Station Components

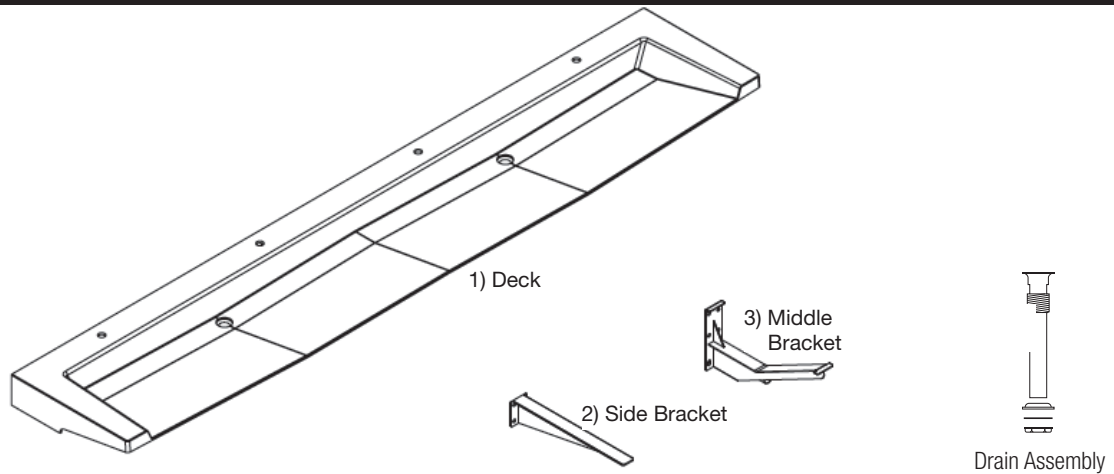

SloanStone® ELA-80000 Sink

CARE & CLEANING

SloanStone Solid Surface Care

For normal cleaning, use warm, soapy water or conventional ammonia based liquid glass cleaner.

For dry stains, allow the soapy water or glass cleaner some time to remoisturize the area, then wipe the stain off.

To renew the surface after deep scratches or stains, use green, then maroon, and finally white 3M Scotch-Brite® pads to return the deck to a smooth 1200 grit wet-sanded finish.

If the dry stain is neither water-based nor oil-based, gently scrape the stain off with a plastic material (i.e. a plastic knife), and then proceed with the aforementioned normal cleaning procedures.

Wipe the entire surface evenly with a mild abrasive cleanser for regular maintenance.

**When assistance is required, please contact
Sloan Technical Support at: 1-888-SLOAN-14 (1-888-756-2614).**

SloanStone® ELWF-80000 Sink

CARE & CLEANING

SloanStone Solid Surface Care

For normal cleaning, use warm, soapy water or conventional ammonia based liquid glass cleaner.

For dry stains, allow the soapy water or glass cleaner some time to remoisturize the area, then wipe the stain off.

To renew the surface after deep scratches or stains, use green, then maroon, and finally white 3M Scotch-Brite® pads to return the deck to a smooth 1200 grit wet-sanded finish.

If the dry stain is neither water-based nor oil-based, gently scrape the stain off with a plastic material (i.e. a plastic knife), and then proceed with the aforementioned normal cleaning procedures.

Wipe the entire surface evenly with a mild abrasive cleanser for regular maintenance.

**When assistance is required, please contact
Sloan Technical Support at: 1-888-SLOAN-14 (1-888-756-2614).**

SloanStone® ELWF-80000 Sink

2 Station Components

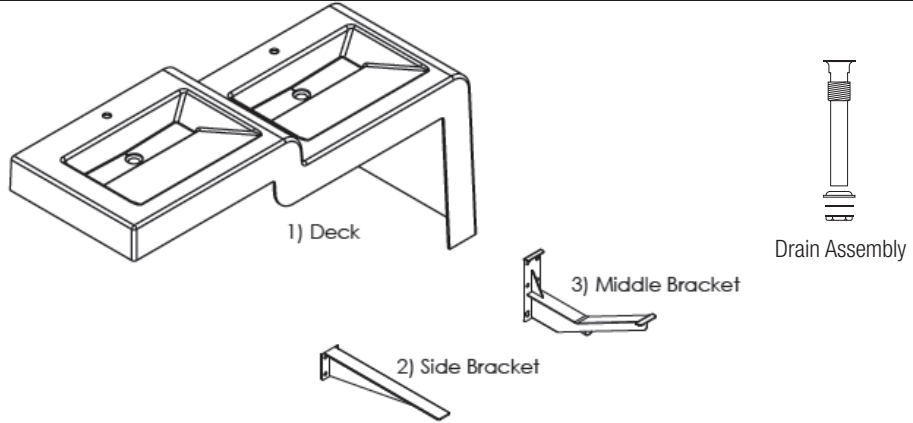

3 Station Components

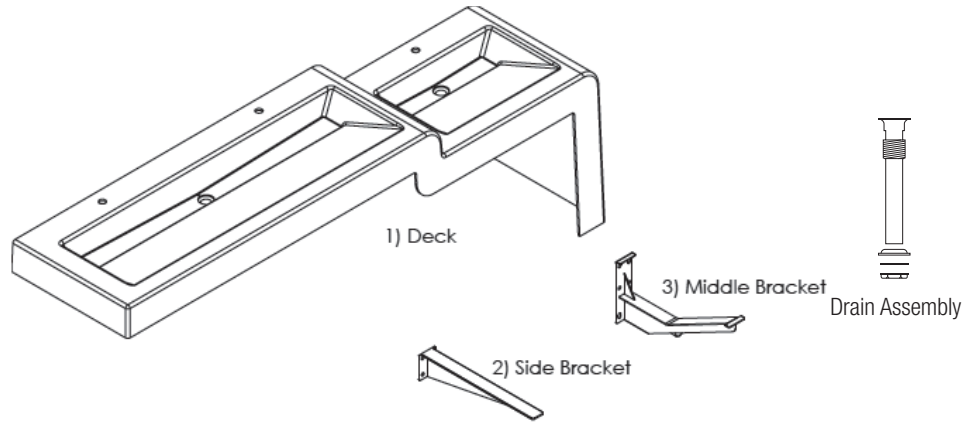

4 Station Components

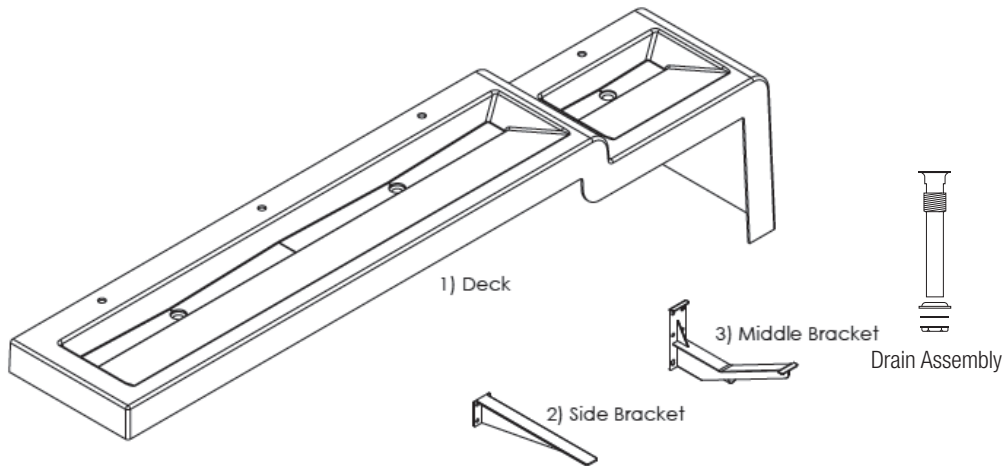

Designers Series™

DSWD-80000 and DSCT-80000 Sinks

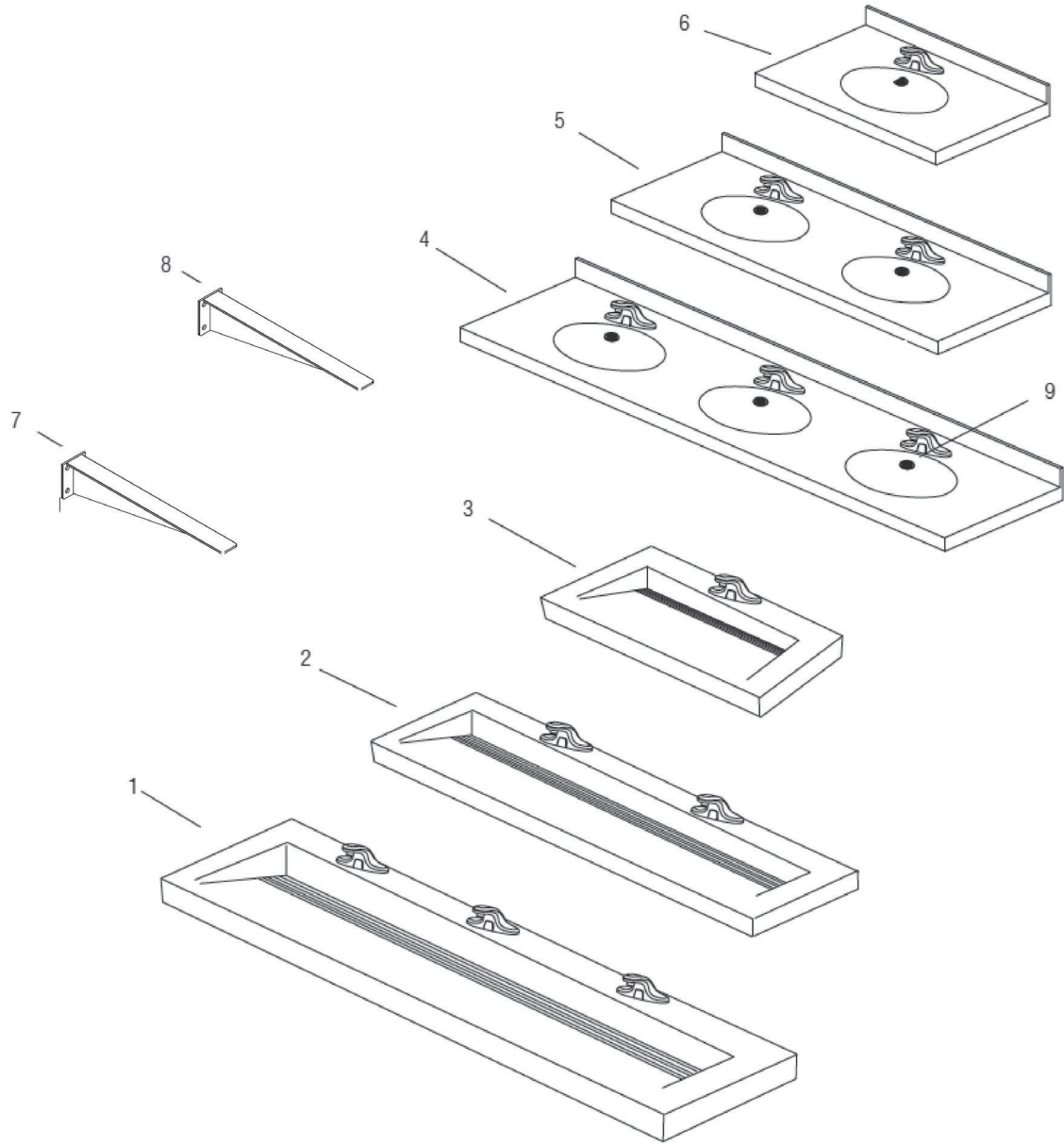

Item No.	Description
1.	DSWD-81000 Wier Deck (single)
2.	DSWD-82000 Wier Deck (double)
3.	DSWD-83000 Wier Deck (triple)
4.	DSCT-83000 Counter Top (triple)
5.	DSCT-82000 Counter Top (double)
6.	DSCT-81000 Counter Top (single)
7.	ELB-3 Right Mounting Bracket (optional/not supplied)
8.	ELB-4 Left Mounting Bracket (optional/not supplied)
9.	ETF-460-A Grid Strainer Assembly
-	Sloan Faucet (model varies/not shown)

Designers Series™

DSWD-80000 and DSCT-80000 Sinks

TROUBLESHOOTING GUIDE

Refer to appropriate faucet pages in Maintenance Guide.

1. No water flows when sensor is activated

Ensure that main power supply is turned "ON." Check receptacle, transformer, batteries (battery powered models), solenoid, leads and connections.

INDICATOR: If Sensor LED does not blink:

- A. Replace control module circuit board is faulty.
- B. Replace sensor module.

INDICATOR: If Sensor LED blinks when user is sensed:

- A. Supply Stop(s) may be closed; open Supply Stop(s).
- B. Debris may be in Solenoid filter; remove, clean and reinstall.

2. Very low flow or slow dribble

- A. Supply Stop(s) may be closed; open Supply Stop(s).
- B. Debris is in solenoid, won't close properly; remove operator and clean. Reassemble in the same manner.
- C. Debris may be in Solenoid filter; remove, clean and reinstall.
- D. Debris is in aerator; remove, clean and reinstall.

3. Continues to run (even after power to faucet has been disconnected)

- A. Solenoid valve is installed backwards; install correctly.
- B. Debris is in solenoid, won't close properly; remove operator and clean. Reassemble in the same manner.

Solenoid Screen Filter Cleaning

- A. Before cleaning the Screen Filter, turn off the water supply at supply stop(s).
- B. Activate the Faucet to relieve any pressure in the system.
- C. Unscrew the Filter Cap and remove it from the Solenoid Valve Housing.
- D. Carefully remove the Screen Filter from the Solenoid Valve Housing.
- E. Clean the Screen Filter using fresh tap water only. If necessary, use a small brush to clean. Use caution while cleaning to prevent damage to Screen Filter.
- F. Examine the Copper Washer or O-ring for wear or damage; replace if necessary. Carefully replace the Screen Filter into Filter Cap. Screw the Filter Cap with Copper Washer or O-ring into Solenoid Valve Housing and tighten securely to prevent leaks.
- G. Turn on the water supply at the supply stop(s). Activate the Faucet to purge any air from the system lines. Check for leaks and repair as necessary.

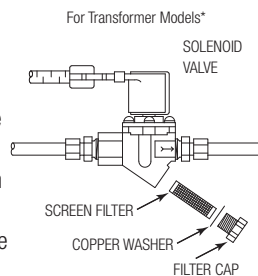

Material Description: Corian Material is made from a blend of acrylic modified bio-based polyester resin. Engineered Stone is 90% natural quartz and polyester resin and is resistant to chemicals, stains, burns and impact. Surface damage can be easily repaired with everyday cleansers or fine grit abrasives.

Routine Cleaning: For regular cleaning, use standard commercial or household products such as Simple Green®, Creamy Cleanser brand, Formula 409® or Windex®.

Stubborn Stains: Remove tough stains, with non abrasive cleaners and pads such as a white Scotch Brite® pad and Lysol®. Special Situations for Corian and Engineered Stone

Hard Water Deposits: Remove hard water deposits with a mild solution of vinegar and water. Always rinse the unit thoroughly after cleaning.

Repair Kits: Corian repair kits are available. Contact your Sloan Stone Sink Systems representative or distributor for part numbers and pricing. Repair kits are made to order and have a shelf life of 30 days. Engineered Stone shades of color can vary from product to product.

BRAND NAMES

Use of brand names is intended only to indicate a type of cleaner. This does not constitute an endorsement, nor does the omission of any brand name cleaner imply inadequacy. Many products named are regional in distribution, and can be found in local supermarkets, department and hardware stores, or through your cleaning service. It is emphasized that all products should be used in strict accordance with package instructions.

**Designer Series™ DSVR-80000 Sink
Discontinued**

DISCONTINUED

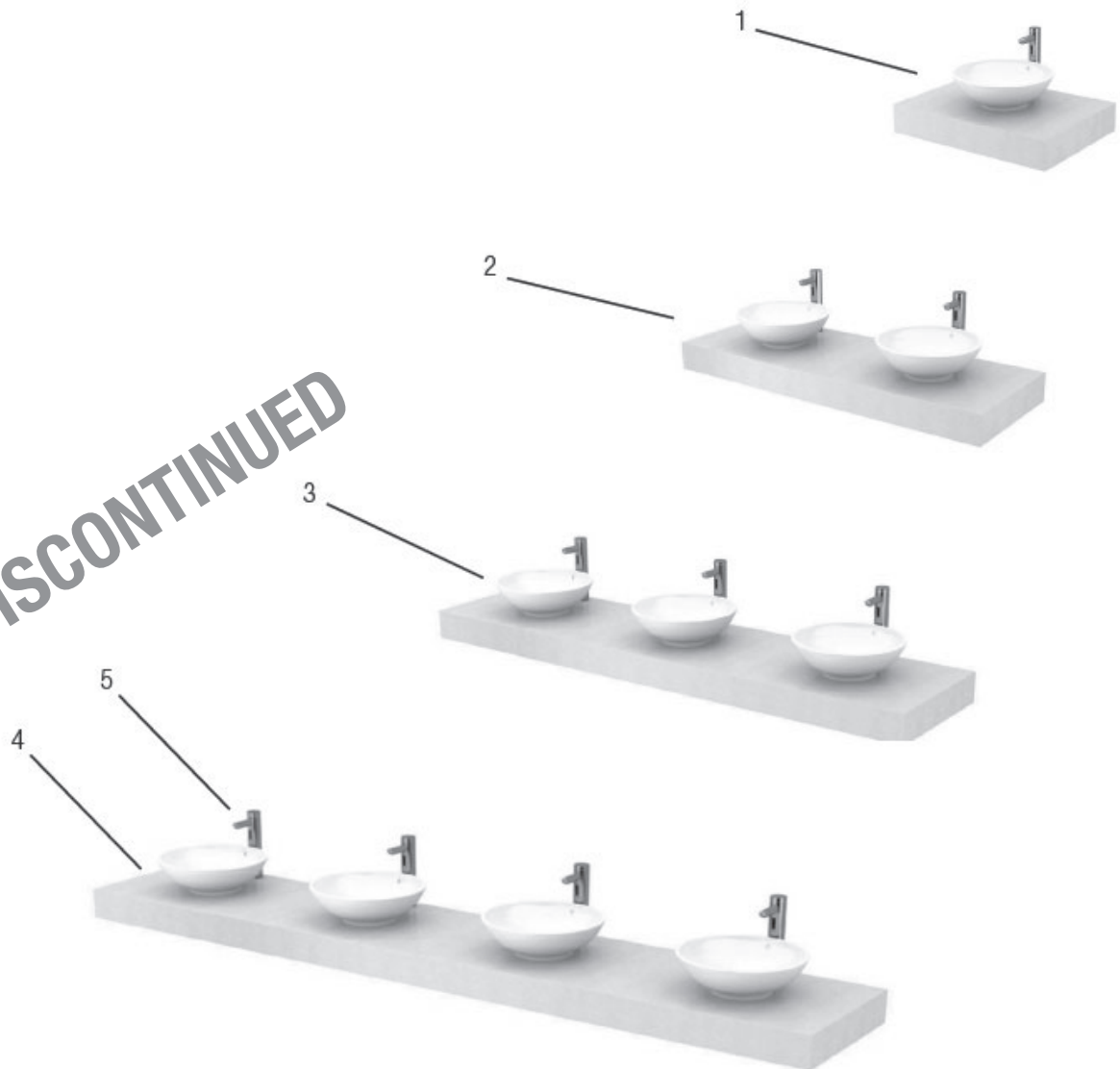

Item No.	Description
1	DSVR-81000 Deck (single)
2	DSVR-82000 Deck (double)
3	DSVR-83000 Deck (triple)
4	DSVR-84000 Deck (quadruple)
5	Sloan Faucet (model varies)
-	Grid Strainer Assembly (not shown)

Designer Series™ DSVR-80000 Sink Discontinued

TROUBLESHOOTING GUIDE

Material Description: Corian Material is made from a blend of acrylic modified bio-based polyester resin. Engineered Stone is 90% natural quartz and polyester resin and is resistant to chemicals, stains, burns and impact. Surface damage can be easily repaired with everyday cleansers or fine grit abrasives.

Routine Cleaning: For regular cleaning, use standard commercial or household products such as Simple Green®, Creamy Cleanser brand, Formula 409® or Windex®.

Stubborn Stains: Remove tough stains, with non abrasive cleaners and pads such as a white Scotch Brite® pad and Lysol®. Special Situations for Corian and Engineered Stone

Hard Water Deposits: Remove hard water deposits with a mild solution of vinegar and water. Always rinse the unit thoroughly after cleaning.

Repair Kits: Corian repair kits are available. Contact your Sloan Stone Sink Systems representative or distributor for part numbers and pricing. Repair kits are made to order and have a shelf life of 30 days. Engineered Stone shades of color can vary from product to product.

BRAND NAMES

Use of brand names is intended only to indicate a type of cleaner. This does not constitute an endorsement, nor does the omission of any brand name cleaner imply inadequacy. Many products named are regional in distribution, and can be found in local supermarkets, department and hardware stores, or through your cleaning service. It is emphasized that all products should be used in strict accordance with package instructions.

Refer to appropriate faucet pages in Maintenance Guide.

1. No water flows when sensor is activated

Ensure that main power supply is turned "ON." Check receptacle, transformer, batteries (battery powered models), solenoid, leads and connections.

INDICATOR: If Sensor LED does not blink:

- A. Replace control module circuit board is faulty.
- B. Replace sensor module.

INDICATOR: If Sensor LED blinks when user is sensed:

- A. Supply Stop(s) may be closed; open Supply Stop(s).
- B. Debris may be in Solenoid filter; remove, clean and reinstall.

2. Very low flow or slow dribble

- A. Supply Stop(s) may be closed; open Supply Stop(s).
- B. Debris is in solenoid, won't close properly; remove operator and clean. Reassemble in the same manner.
- C. Debris may be in Solenoid filter; remove, clean and reinstall.
- D. Debris is in aerator; remove, clean and reinstall.

3. Continues to run (even after power to faucet has been disconnected)

- A. Solenoid valve is installed backwards; install correctly.
- B. Debris is in solenoid, won't close properly; remove operator and clean. Reassemble in the same manner.

DISCONTINUED

SloanStone® EWF-40000 Sink



EWF-42000, EWF-43000 AND EWF-44000 PARTS

Item No.	Code No.	Part No.	Description
1A.	—	—	Actuator Housing Assembly Cover (double station)
1B.	—	—	Actuator Housing Assembly Cover (triple station)
1C.	—	—	Actuator Housing Assembly Cover (quadruple station)
2.	—	—	Sensor
3A.	—	—	Actuator Housing Assembly (double station)
3B.	—	—	Actuator Housing Assembly (triple station)
3C.	—	—	Actuator Housing Assembly (quadruple station)
4.	—	—	Spray Head
5.	—	—	Strainer
6.	—	—	1½" Drain Spud
7A.	—	—	Solid Surface Basin (double station)
7B.	—	—	Solid Surface Basin (triple station)
7C.	—	—	Solid Surface Basin (quadruple station)
8.	—	—	Washer
9.	—	—	Locknut
10A.	—	—	Pedestal (double station)
10B.	—	—	Pedestal (triple station)
10C.	—	—	Pedestal (quadruple station)
11A.	—	—	Solid Surface Access Cover (double station)
11B.	—	—	Solid Surface Access Cover (triple station)
11C.	—	—	Solid Surface Access Cover (quadruple station)

MIXING VALVE

0326045	MIX-135-A	Below Deck Thermostatic Water Mixing Valve (BDT Variation)
----------------	-----------	--

REPAIR KITS

3305622	EL-1500-LL	Sensor – Lavatory
3305527	ETF-1004-A	Solenoid
3305577	ETF-1009-A	Solenoid Valve Repair Kit

— Consult factory for replacement part.
 — Consult factory for replacement part.

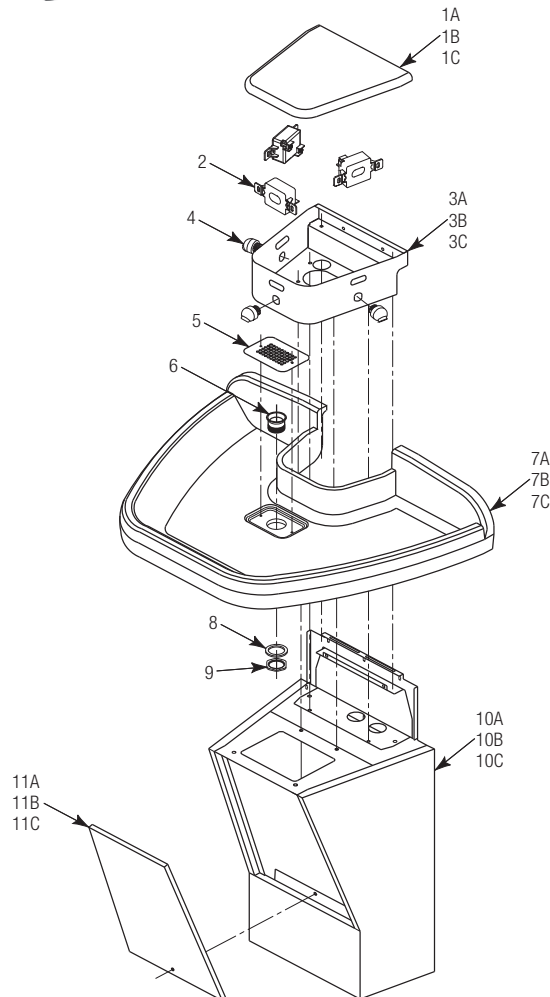

SloanStone® EWF-40000 Sink

TROUBLESHOOTING GUIDE

1. No water flows when sensor is activated

Ensure that main power supply is turned "ON." Check receptacle, transformer, solenoid, leads and connections.

INDICATOR: If Sensor LED does not blink:

- A. Replace control module circuit board.
- B. Replace sensor module.

INDICATOR: If Sensor LED blinks when user is sensed:

- A. Supply Stop(s) may be closed; open Supply Stop(s).
- B. Debris may be in Solenoid filter; remove, clean and reinstall.

2. Very low flow or slow dribble

- A. Supply Stop(s) may be closed; open Supply Stop(s).
- B. Debris is in solenoid, won't close properly; remove operator and clean. Reassemble in the same manner.
- C. Debris may be in Solenoid filter; remove, clean and reinstall.
- D. Debris is in spray head; remove, clean and reinstall.

3. Continues to run (even after power to faucet has been disconnected)

- A. Solenoid valve is installed backwards; install correctly.
- B. Debris is in solenoid, won't close properly; remove operator and clean. Reassemble in the same manner.

SOLENOID SCREEN FILTER CLEANING

- A. Before cleaning the Screen Filter, turn off the water supply at supply stop(s).
- B. Activate the Spray Head to relieve any pressure in the system.
- C. Unscrew the Filter Cap and remove it from the Solenoid Valve Housing.
- D. Carefully remove the Screen Filter from the Solenoid Valve Housing.
- E. Clean the Screen Filter using fresh tap water only. If necessary, use a small brush to clean. Use caution while cleaning to prevent damage to Screen Filter.
- F. Examine the Copper Washer for wear or damage; replace if necessary. Carefully replace the Screen Filter into the Filter Cap. Screw the Filter Cap with Copper Washer into the Solenoid Valve Housing and tighten securely to prevent leaks.
- G. Turn on the water supply at the supply stop(s). Activate the Spray Head to purge any air from the system lines. Check for leaks and repair as necessary.

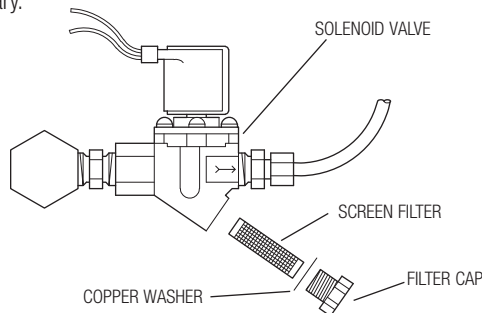

SloanStone® Solid Surface Care

For normal cleaning, use warm, soapy water or conventional ammonia based liquid glass cleaner.

For dry stains, allow the soapy water or glass cleaner some time to remoisturize the area, then wipe the stain off.

To renew the surface after deep scratches or stains, use green, then maroon, and finally white 3M Scotch-Brite® pads to return the deck to a smooth 1200 grit wet-sanded finish.

If the dry stain is neither water-based nor oil-based, gently scrape the stain off with a plastic material (i.e. a plastic knife), and then proceed with the aforementioned normal cleaning procedures.

Wipe the entire surface evenly with a mild abrasive cleanser for regular maintenance.

Stainless Steel Care

Important: When cleaning stainless steel, always rub in the same direction of the stainless steel finish lines, never across. After cleaning, always thoroughly rinse with water and dry all cleaned stainless steel areas to prevent buildup of mineral deposits.

Clean stainless steel surfaces often using warm, soapy water.

For more stubborn deposits, use baking soda, borax or any of several non-abrasive commercial cleansing agents. Do not leave chlorides found in most cleansing agents for extended periods of time on the surfaces as they may attack stainless steel. If an abrasive cleaning tool is needed, always use stainless steel wool, stainless steel pads, or stainless steel brushes. Do not use ordinary steel wool, pads or brushes because they have a tendency to break apart and leave small particles which will rust on the stainless steel surfaces, giving the appearance that the stainless steel surfaces themselves are rusting. Do not use strong acidic or caustic cleaners or cleansers because they may also attack the stainless steel surfaces. Maintain a regular cleaning schedule.

**When assistance is required, please contact
Sloan Technical Support at: 1-888-SLOAN-14 (1-888-756-2614).**

SloanStone® ELC-40000 & ELC-70000 Sinks



ELC-41000
Single Station



ELC-42000
Double Station



ELC-43000
Triple Station



ELC-44000
Quadruple Station

SENSOR ACTIVATED SOLID SURFACE LAVATORY SYSTEM PARTS

Item			
No.	Code No.	Part No.	Description
1A.	—	—	Solid Surface Basin (single)
1B.	—	—	Solid Surface Basin (double)
1C.	—	—	Solid Surface Basin (triple)
1D.	—	—	Solid Surface Basin (quadruple)
2.	—	—	Faucet (Model Varies)
3.	—	—	Strainer Assembly
4.	0387384	ELB-3	Right Mounting Bracket (Optional)
5.	0387385	ELB-4	Left Mounting Bracket (Optional)

— Consult factory for replacement part.
— Consult factory for replacement part.

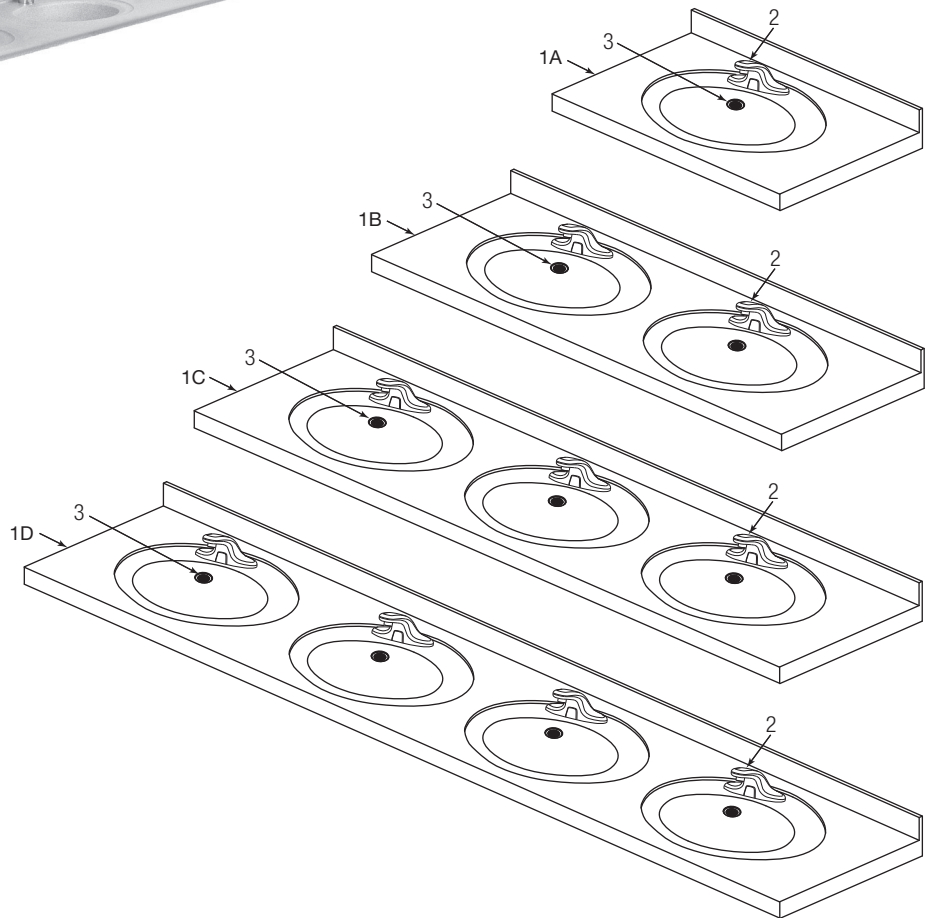
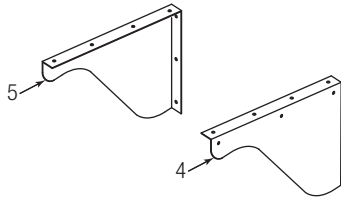

SloanStone® ELC-40000 & ELC-70000 Sinks

TROUBLESHOOTING GUIDE

Refer to appropriate faucet pages in Maintenance Guide.

1. No water flows when sensor is activated

Ensure that main power supply is turned "ON." Check receptacle, transformer, batteries (battery powered models), solenoid, leads and connections.

INDICATOR: If Sensor LED does not blink:

- A. Control module circuit board is faulty; replace.
- B. Sensor is faulty; replace sensor module.

INDICATOR: If Sensor LED blinks when user is sensed:

- A. Supply Stop(s) may be closed; open Supply Stop(s).
- B. Debris may be in Solenoid filter; remove, clean and reinstall.

2. Very low flow or slow dribble

- A. Supply Stop(s) may be closed; open Supply Stop(s).
- B. Debris is in solenoid, won't close properly; remove operator and clean. Reassemble in the same manner.
- C. Debris may be in Solenoid filter; remove, clean and reinstall.
- D. Debris is in aerator; remove, clean and reinstall.

3. Continues to run (even after power to faucet has been disconnected)

- A. Solenoid valve is installed backwards; install correctly.
- B. Debris is in solenoid, won't close properly; remove operator and clean. Reassemble in the same manner.

Solenoid Screen Filter Cleaning

- A. Before cleaning the Screen Filter, turn off the water supply at supply stop(s).
- B. Activate the Faucet to relieve any pressure in the system.
- C. Unscrew the Filter Cap and remove it from the Solenoid Valve Housing.
- D. Carefully remove the Screen Filter from the Solenoid Valve Housing.
- E. Clean the Screen Filter using fresh tap water only. If necessary, use a small brush to clean. Use caution while cleaning to prevent damage to Screen Filter.
- F. Examine the Copper Washer or O-ring for wear or damage; replace if necessary. Carefully replace the Screen Filter into Filter Cap. Screw the Filter Cap with Copper Washer or O-ring into Solenoid Valve Housing and tighten securely to prevent leaks.
- G. Turn on the water supply at the supply stop(s). Activate the Faucet to purge any air from the system lines. Check for leaks and repair as necessary.

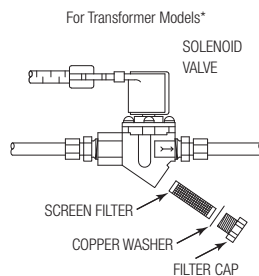

SloanStone® Solid Surface Care

For normal cleaning, use warm, soapy water or conventional ammonia based liquid glass cleaner.

For dry stains, allow the soapy water or glass cleaner some time to remoisturize the area, then wipe the stain off.

To renew the surface after deep scratches or stains, use green, then maroon, and finally white 3M Scotch-Brite® pads to return the deck to a smooth 1200 grit wet-sanded finish.

If the dry stain is neither water-based nor oil-based, gently scrape the stain off with a plastic material (i.e. a plastic knife), and then proceed with the aforementioned normal cleaning procedures.

Wipe the entire surface evenly with a mild abrasive cleanser for regular maintenance.

When assistance is required, please contact

Sloan Technical Support at: 1-888-SLOAN-14 (1-888-756-2614).

SloanStone® ELC-81000/82000/83000 Sinks

Parts List

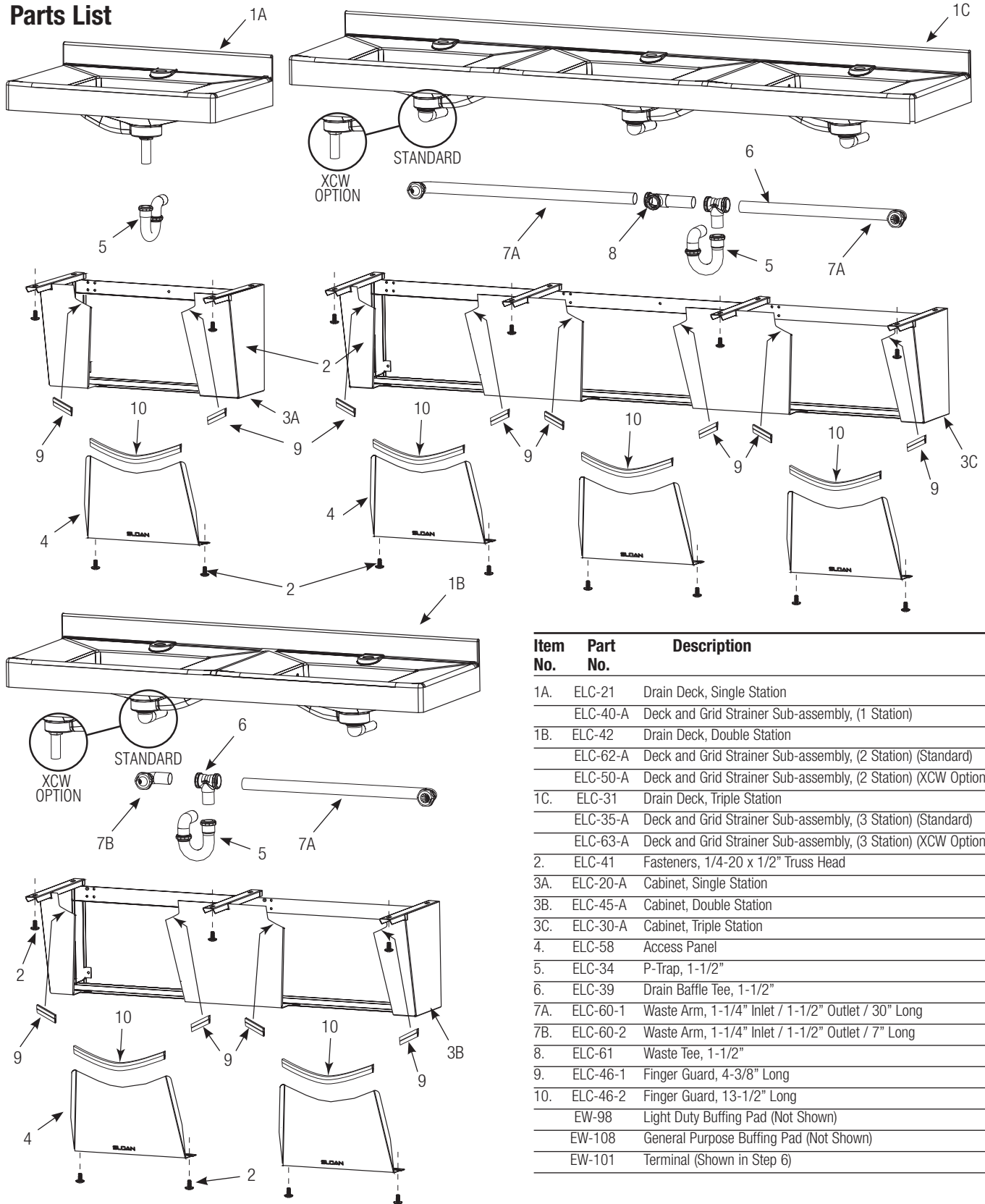

Item No.	Part No.	Description
1A.	ELC-21	Drain Deck, Single Station
	ELC-40-A	Deck and Grid Strainer Sub-assembly, (1 Station)
1B.	ELC-42	Drain Deck, Double Station
	ELC-62-A	Deck and Grid Strainer Sub-assembly, (2 Station) (Standard)
	ELC-50-A	Deck and Grid Strainer Sub-assembly, (2 Station) (XCW Option)
1C.	ELC-31	Drain Deck, Triple Station
	ELC-35-A	Deck and Grid Strainer Sub-assembly, (3 Station) (Standard)
	ELC-63-A	Deck and Grid Strainer Sub-assembly, (3 Station) (XCW Option)
2.	ELC-41	Fasteners, 1/4-20 x 1/2" Truss Head
3A.	ELC-20-A	Cabinet, Single Station
3B.	ELC-45-A	Cabinet, Double Station
3C.	ELC-30-A	Cabinet, Triple Station
4.	ELC-58	Access Panel
5.	ELC-34	P-Trap, 1-1/2"
6.	ELC-39	Drain Baffle Tee, 1-1/2"
7A.	ELC-60-1	Waste Arm, 1-1/4" Inlet / 1-1/2" Outlet / 30" Long
7B.	ELC-60-2	Waste Arm, 1-1/4" Inlet / 1-1/2" Outlet / 7" Long
8.	ELC-61	Waste Tee, 1-1/2"
9.	ELC-46-1	Finger Guard, 4-3/8" Long
10.	ELC-46-2	Finger Guard, 13-1/2" Long
	EW-98	Light Duty Buffing Pad (Not Shown)
	EW-108	General Purpose Buffing Pad (Not Shown)
	EW-101	Terminal (Shown in Step 6)

SloanStone® ELGR-80000 Sink

ELGR-81000

One Station Lavatory Systems

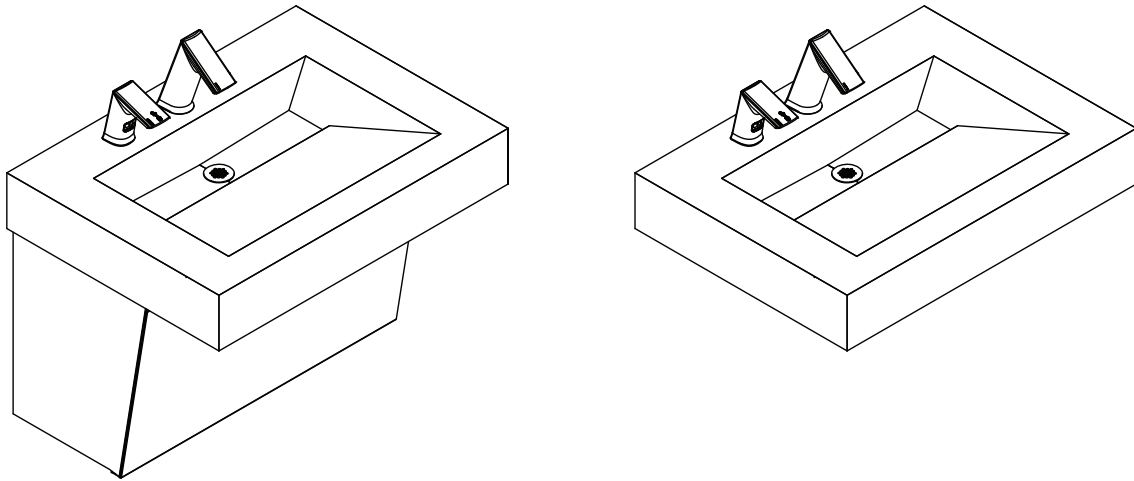

Sink Location

Determine the appropriate wall location for the Lavatory System. Consider that hot and cold water supply lines, a drain line, and an electrical source (receptacle for hardwired faucets and hand dryer) will be required. Compare the physical dimensions of the Lavatory System to the space available for the installation. If wall is not load bearing, a carrier may be required behind the wall. Refer to the appropriate Rough-in diagrams for Lavatory System dimensions. Prior to Lavatory System installation, electric wiring, water supply and drain must be installed.

ELGR-81000, One Station Components

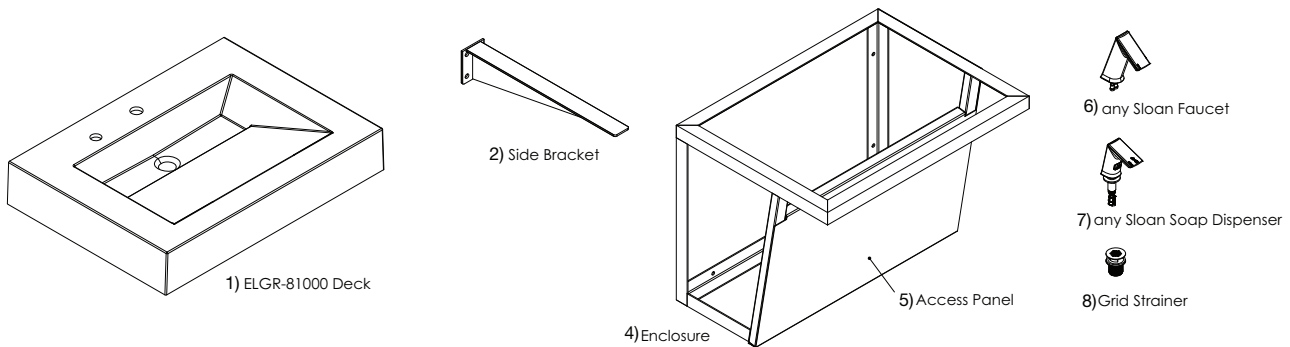

Note:
Faucet and soap dispenser models shown for reference, actual units will depend on what was selected at order entry.

ELGR-81000, One Station Component List

Description	Item Number	Quantity
Designer Series ELGR, One Station, Deck	1	1
Side Bracket <i>(Mounting Option, 0386063)</i>	2	2
Middle Bracket <i>(Mounting Option, 0386064, not required for single station)</i>	3	-
Angled Enclosure <i>(Mounting Option)</i>	4	1
Hook and Hang Access Panel	5	1
any Sloan Faucet	6	1
any Sloan Soap Dispenser Note: If ESD-500 Selected – Area under the sink must be clear for proper installation access and soap bottle change (no outlets, stops, etc).	7	1

SloanStone® ELGR-80000 Sink

ELGR-82000

Two Station Lavatory Systems

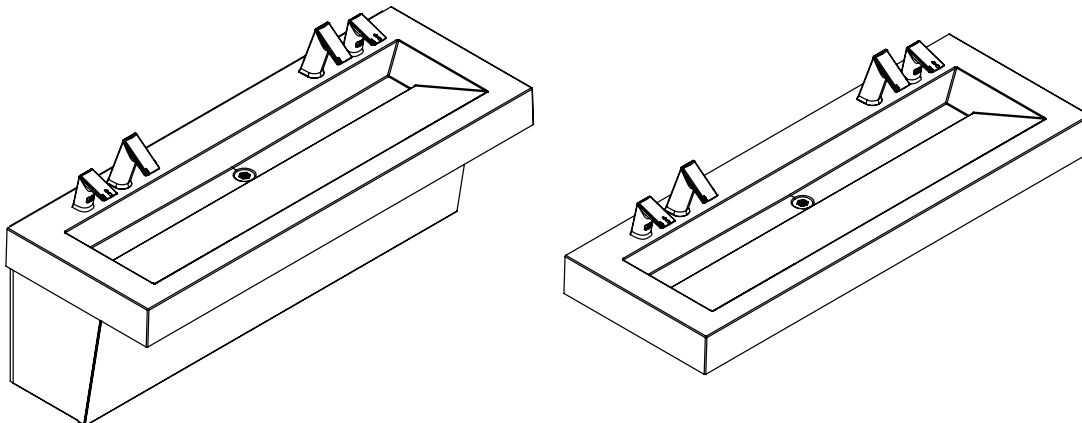

Sink Location

Determine the appropriate wall location for the Lavatory System. Consider that hot and cold water supply lines, a drain line, and an electrical source (receptacle for hardwired faucets and hand dryer) will be required. Compare the physical dimensions of the Lavatory System to the space available for the installation. If wall is not load bearing, a carrier may be required behind the wall. Refer to the appropriate Rough-in diagrams for Lavatory System dimensions. Prior to Lavatory System installation, electric wiring, water supply and drain must be installed.

ELGR-82000, Two Station Components

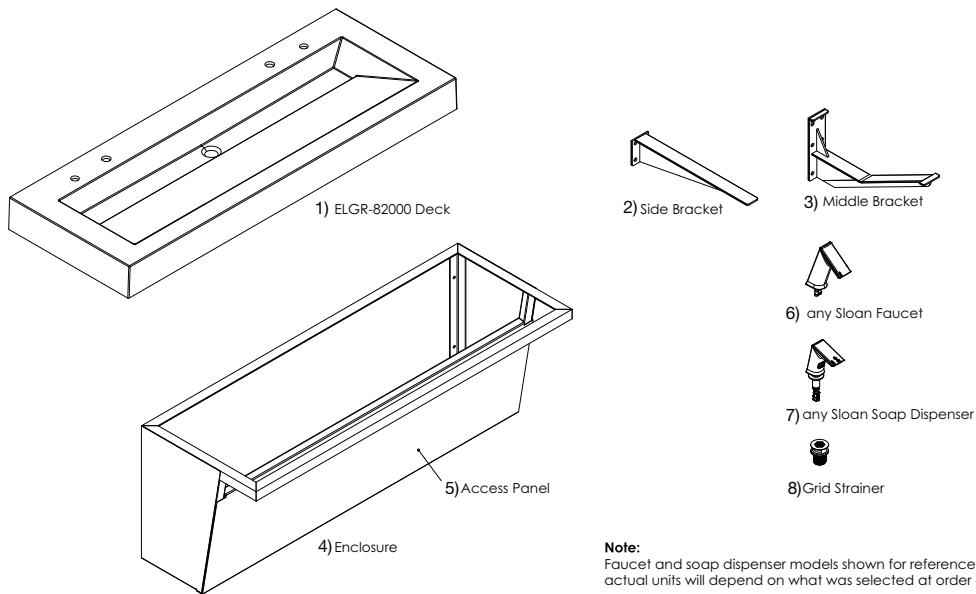

Note:
Faucet and soap dispenser models shown for reference, actual units will depend on what was selected at order entry.

ELGR-82000, Two Station Component List

Description	Item Number	Quantity
Designer Series ELGR, Two Station, Deck	1	1
Side Bracket (<i>Mounting Option, 0386063</i>)	2	2
Middle Bracket (<i>Mounting Option, 0386064</i>)	3	2
Angled Enclosure (<i>Mounting Option</i>)	4	1
Hook and Hang Access Panel	5	1
any Sloan Faucet	6	2
any Sloan Soap Dispenser Note: If ESD-500 Selected – Area under the sink must be clear for proper installation access and soap bottle change (no outlets, stops, etc).	7	2
Grid Strainer	8	1

SloanStone® ELGR-80000 Sink

ELGR-83000

Three Station Lavatory Systems

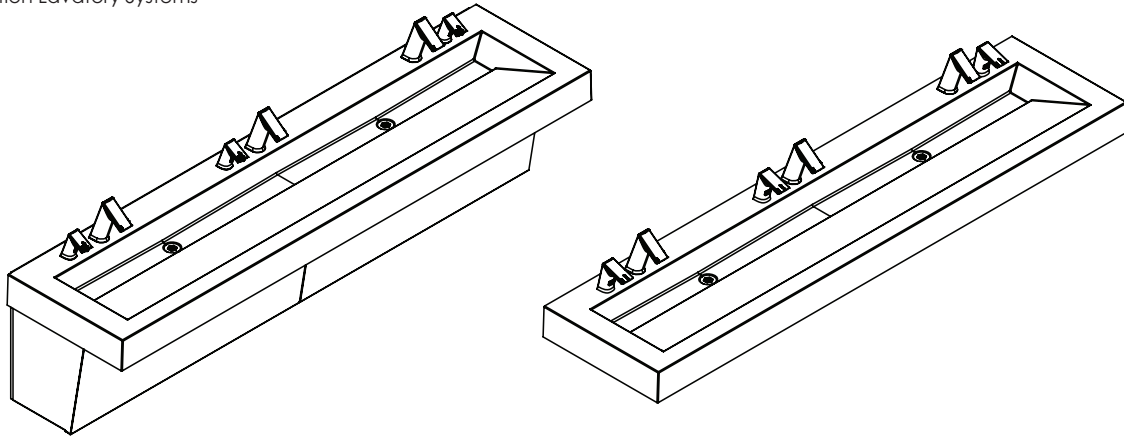

Sink Location

Determine the appropriate wall location for the Lavatory System. Consider that hot and cold water supply lines, a drain line, and an electrical source (receptacle for hardwired faucets and hand dryer) will be required. Compare the physical dimensions of the Lavatory System to the space available for the installation. If wall is not load bearing, a carrier may be required behind the wall. Refer to the appropriate Rough-in diagrams for Lavatory System dimensions. Prior to Lavatory System installation, electric wiring, water supply and drain must be installed.

ELGR-83000, Three Station Components

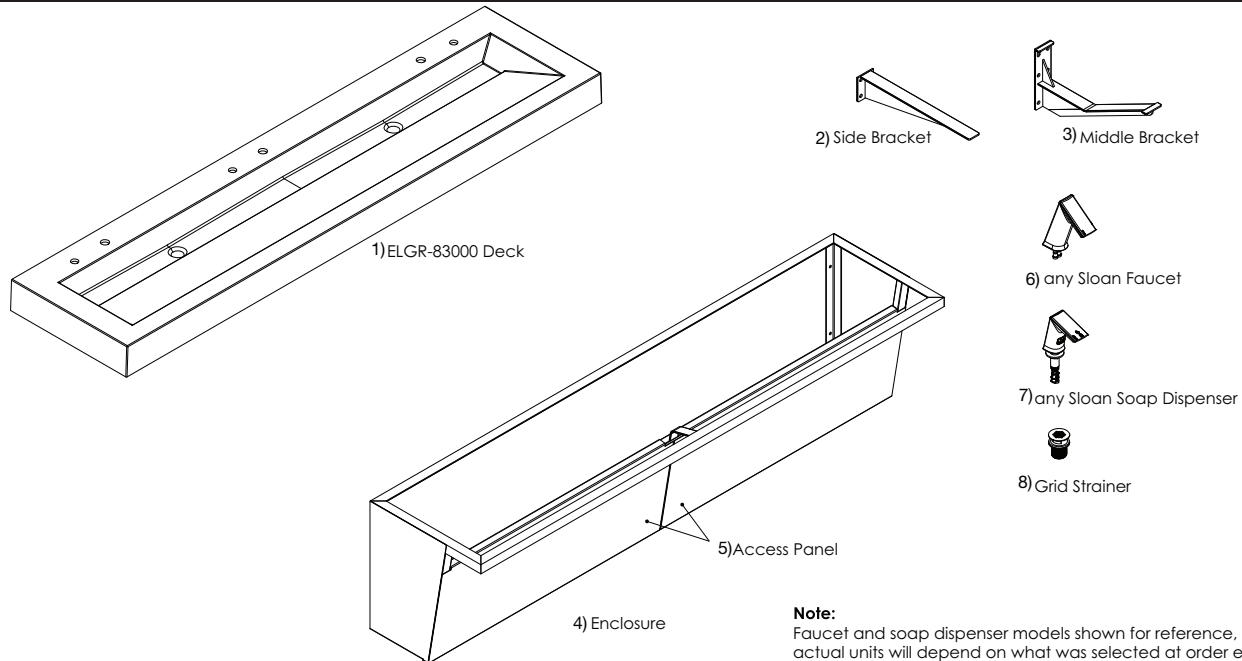

ELGR-83000, Three Station Component List

Description	Item Number	Quantity
Designer Series ELGR, Three Station, Deck	1	1
Side Bracket <i>(Mounting Option, 0386063)</i>	2	2
Middle Bracket <i>(Mounting Option, 0386064)</i>	3	4
Angled Enclosure <i>(Mounting Option)</i>	4	1
Hook and Hang Access Panel	5	2
any Sloan Faucet	6	3
any Sloan Soap Dispenser Note: If ESD-500 Selected – Area under the sink must be clear for proper installation access and soap bottle change (no outlets, stops, etc).	7	3
Grid Strainer	8	2

SloanStone® ELGR-80000 Sink

ELGR-84000

Four Station Lavatory Systems

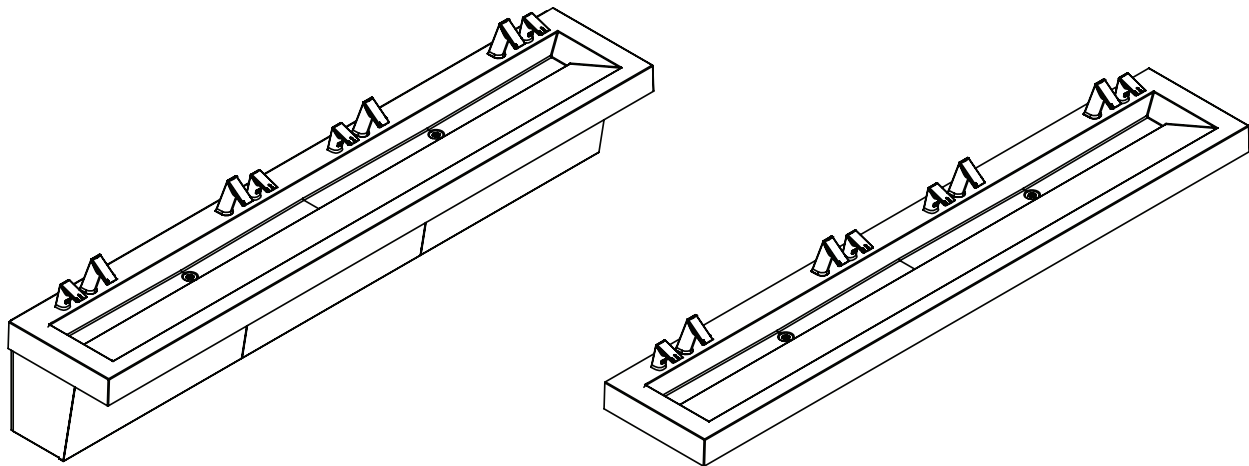

Sink Location

Determine the appropriate wall location for the Lavatory System. Consider that hot and cold water supply lines, a drain line, and an electrical source (receptacle for hardwired faucets and hand dryer) will be required. Compare the physical dimensions of the Lavatory System to the space available for the installation. If wall is not load bearing, a carrier may be required behind the wall. Refer to the appropriate Rough-in diagrams for Lavatory System dimensions. Prior to Lavatory System installation, electric wiring, water supply and drain must be installed.

ELGR-84000, Four Station Components

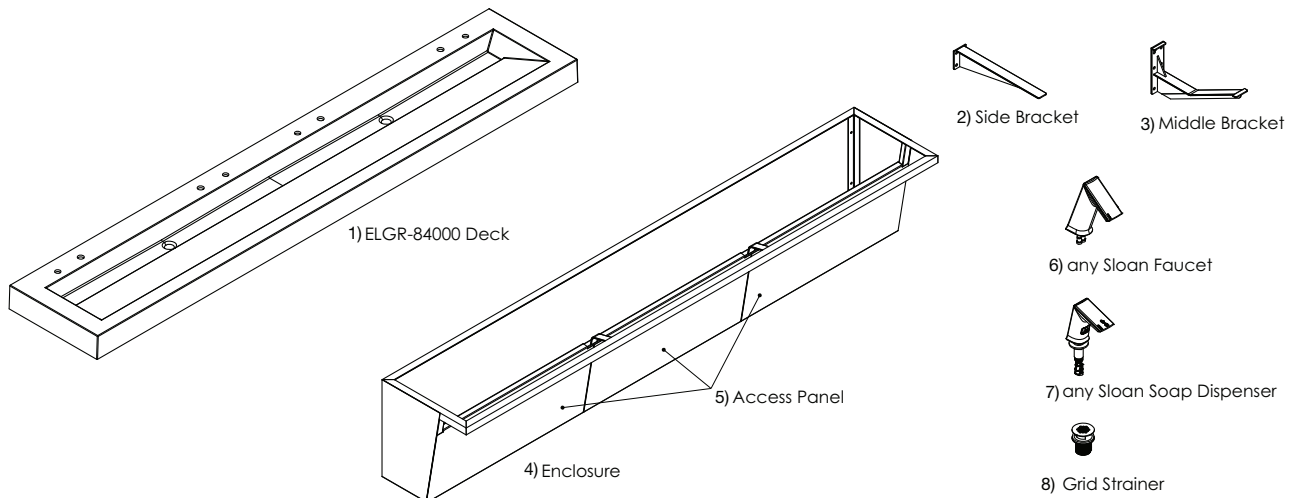

Note:
Faucet and soap dispenser models shown for reference, actual units will depend on what was selected at order entry.

ELGR-84000, Four Station Component List

Description	Item Number	Quantity
Designer Series ELGR, Four Station, Deck	1	1
Side Bracket (Mounting Option, 0386063)	2	2
Middle Bracket (Mounting Option, 0386064)	3	6
Angled Enclosure (Mounting Option)	4	1
Hook and Hang Access Panel	5	3
any Sloan Faucet	6	4
any Sloan Soap Dispenser Note: If ESD-500 Selected – Area under the sink must be clear for proper installation access and soap bottle change (no outlets, stops, etc).	7	4
Grid Strainer	8	2

SloanStone® ELGR-80000 Sink

TROUBLESHOOTING GUIDE

Refer to appropriate faucet pages in Maintenance Guide.

1. No water flows when sensor is activated

Ensure that main power supply is turned "ON." Check receptacle, transformer, batteries (battery powered models), solenoid, leads and connections.

INDICATOR: If Sensor LED does not blink:

- A. Control module circuit board is faulty; replace.
- B. Sensor is faulty; replace sensor module.

INDICATOR: If Sensor LED blinks when user is sensed:

- A. Supply Stop(s) may be closed; open Supply Stop(s).
- B. Debris may be in Solenoid filter; remove, clean and reinstall.

2. Very low flow or slow dribble

- A. Supply Stop(s) may be closed; open Supply Stop(s).
- B. Debris is in solenoid, won't close properly; remove operator and clean. Reassemble in the same manner.
- C. Debris may be in Solenoid filter; remove, clean and reinstall.
- D. Debris is in aerator; remove, clean and reinstall.

3. Continues to run (even after power to faucet has been disconnected)

- A. Solenoid valve is installed backwards; install correctly.
- B. Debris is in solenoid, won't close properly; remove operator and clean. Reassemble in the same manner.

Solenoid Screen Filter Cleaning

- A. Before cleaning the Screen Filter, turn off the water supply at supply stop(s).
- B. Activate the Faucet to relieve any pressure in the system.
- C. Unscrew the Filter Cap and remove it from the Solenoid Valve Housing.
- D. Carefully remove the Screen Filter from the Solenoid Valve Housing.
- E. Clean the Screen Filter using fresh tap water only. If necessary, use a small brush to clean.
Use caution while cleaning to prevent damage to Screen Filter.
- F. Examine the Copper Washer or O-ring for wear or damage; replace if necessary. Carefully replace the Screen Filter into Filter Cap. Screw the Filter Cap with Copper Washer or O-ring into Solenoid Valve Housing and tighten securely to prevent leaks.
- G. Turn on the water supply at the supply stop(s). Activate the Faucet to purge any air from the system lines. Check for leaks and repair as necessary.

SloanStone® Solid Surface Care

For normal cleaning, use warm, soapy water or conventional ammonia based liquid glass cleaner.

For dry stains, allow the soapy water or glass cleaner some time to re moisturize the area, then wipe the stain off.

To renew the surface after deep scratches or stains, use green, then maroon, and finally white 3M Scotch-Brite® pads to return the deck to a smooth 1200 grit wet-sanded finish.

If the dry stain is neither water-based nor oil-based, gently scrape the stain off with a plastic material (i.e. a plastic knife), and then proceed with the aforementioned normal cleaning procedures.

Wipe the entire surface evenly with a mild abrasive cleanser for regular maintenance.

**When assistance is required, please contact
Sloan Technical Support at: 1-888-SLOAN-14 (1-888-756-2614).**

SloanStone® ELS-72000 Sink



DOUBLE STATION SENSOR ACTIVATED SOLID SURFACE LAVATORY SYSTEM PARTS

Item No.	Code No.	Part No.	Description
1.	—	EW-20-A	Cabinet Weldment, 2 Station
2.	0387099	EW-99	U-Type Nut Standard 1/4-20 Thread (6)
3.	—	EW-60	End Cap Right – Machined
4.	—	EW-52	End Cap Left – Machined
5.	—	EW-15	Screw, Pan Head 1/4-20 x 1/2" Long (SEMS)
6.	—	EW-16	Screw, Pan Head 1/4-20 x 1" Long (SEMS) (4)
7.	0387006	EW-25	Front Panel, 2 Station
8.	SEE TABLE BELOW		Double Station Lavatory Basin Assembly
9.	—	ETF-725-A	Grid Strainer Assembly (2)
10.	—	EW-15	Screw, Pan Head 1/4-20 x 1/2" Long (SEMS)
11.	—	EW-61	Overflow Cover Plate (2)
	—	EW-98	Light Duty Buffing Pad (not shown)
	0387099	EW-99	U-Type Nut Std. 1/4"-20 Thread

— Consult factory for replacement part.

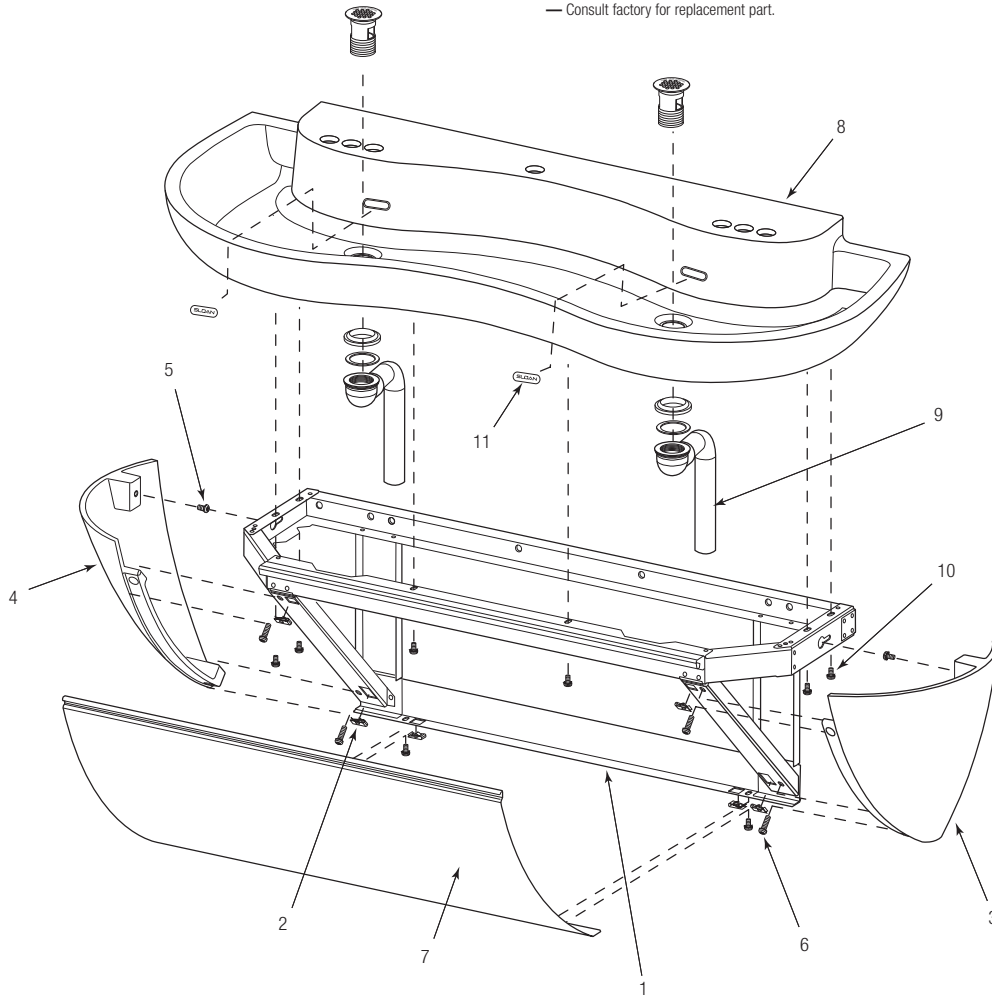

ITEM NO. 8 – DOUBLE STATION LAVATORY BASIN HOLE PATTERNS

Hole Pattern	—	A	B	C	D
Part Number	ELS-12-A-XX	ELS-12-A-XX-A	ELS-12-A-XX-B	ELS-12-A-XX-C	ELS-12-A-XX-D
Basin Hole Pattern					

SloanStone® ELS-73000 Sink



TRIPLE STATION SENSOR ACTIVATED SOLID SURFACE LAVATORY SYSTEM PARTS

Item No.	Code No.	Part No.	Description
1.	—	EW-30-A	Cabinet Weldment, 3 Station
2.	—	EW-50	Front Panel Support – Machined
3.	—	EW-36	Screw, Pan Head #8-32 x 7/16" Long (SEMS) (2)
4.	0387099	EW-99	U-Type Nut Standard 1/4-20 Thread (6)
5.	—	EW-60	End Cap Right – Machined
6.	—	EW-52	End Cap Left – Machined
7.	—	EW-16	Screw, Pan Head 1/4-20 x 1" Long (SEMS) (4)
8.	—	EW-15	Screw, Pan Head 1/4-20 x 1/2" Long (SEMS) (2)
9.	0387035	EW-35	Front Panel, 3 Station (2)
10.	SEE TABLE BELOW		Triple Station Lavatory Basin Assembly
11.	—	ETF-725-A	Grid Strainer Assembly (2)
12.	—	EW-15	Screw, Pan Head 1/4-20 x 1/2" Long (SEMS) (8)
13.	—	EW-61	Overflow Cover Plate (2)
		EW-98	Light Duty Buffing Pad (not shown)
		EW-108	Heavy Duty Buffing Pad (not shown)

— Consult factory for replacement part.

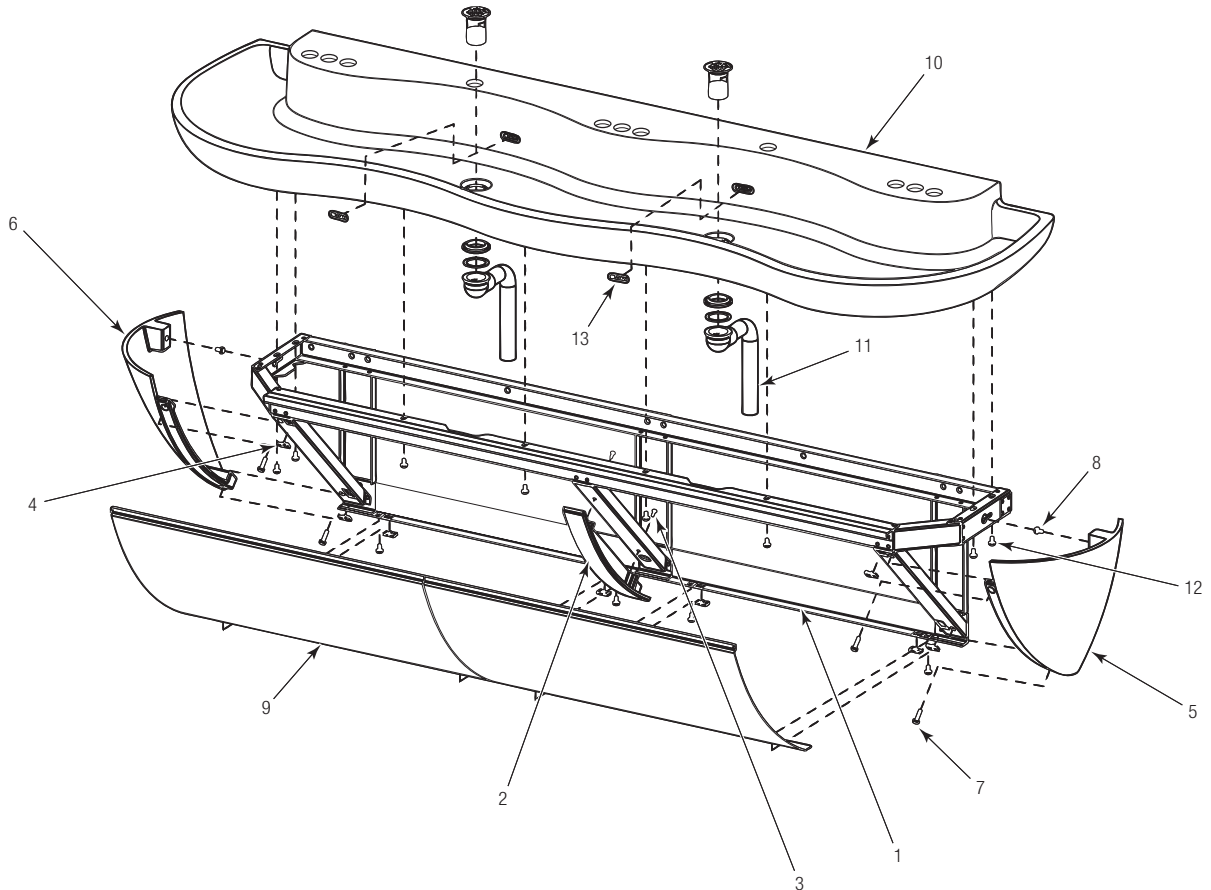



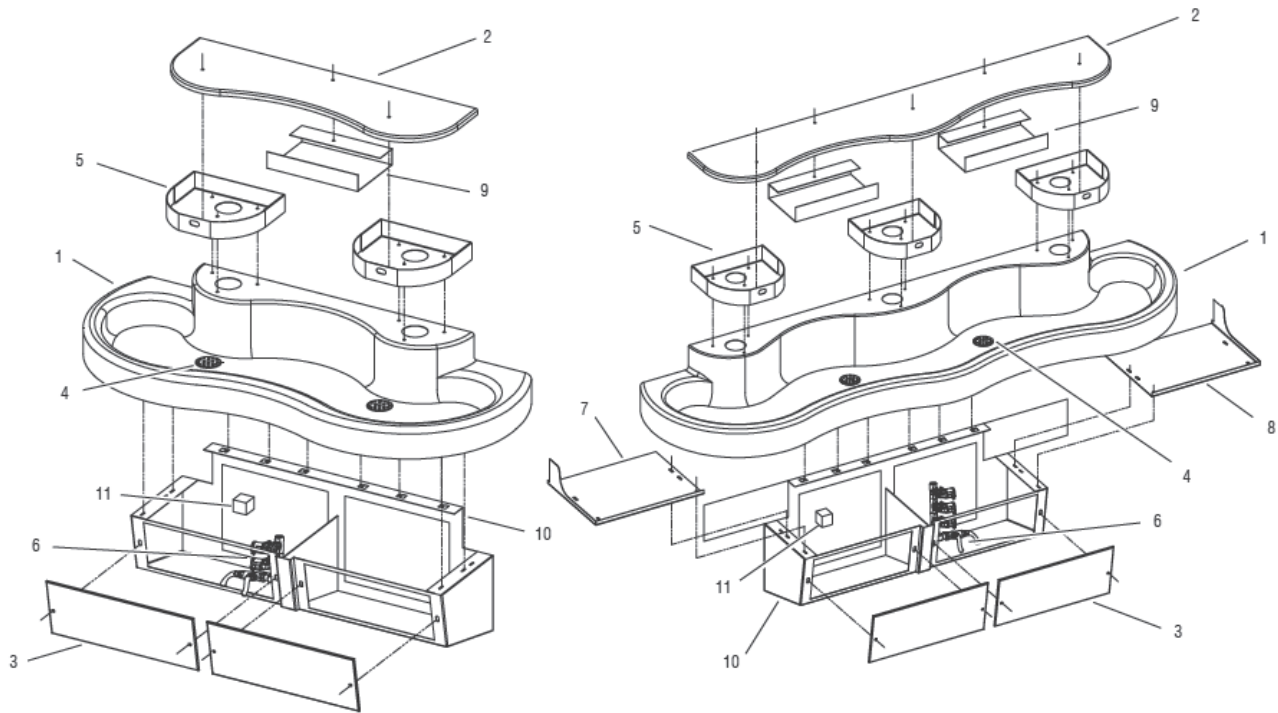

ITEM NO. 10 – TRIPLE STATION LAVATORY BASIN HOLE PATTERNS

Hole Pattern	—	A	B	C	D
Part Number	ELS-13-A-XX	ELS-13-A-XX-A	ELS-13-A-XX-B	ELS-13-A-XX-C	ELS-13-A-XX-D
Basin Hole Pattern					



SloanStone® EW-42000/43000 Sinks



Hardware Kit

- 1/4-20 x 4" THREADED ROD 
- 1/4-20 x 1 1/2" FASTENER 
- 1/4-20 x 1" FASTENER 
- 1/4-20 x 1" FASTENER (FLAT HEAD) 
- 1/4-20 x 1/2" FASTENER 

- 1/4-20 x 7/8" COUPLING NUT 
- 4 WAY WIRE TIE BASE 
- AERATOR KEY 

- 4" WIRE TIE WRAP 
- 1/4-20 TINNEMAN NUT 
- 1/4-20 WING NUT 
- TT30 PINNED TORX BIT 
- TT27 PINNED TORX BIT 

Item No.	Description
1.	Sold Surface Basin
2.	Solid Surface Top Cover
3.	Front Panels
4.	Front Panels (LP)
5.	Actuator Assembly
6.	Electronic Valve Assembly
7.	Left Side Closure Panel
8.	Right Side Closure Panel
9.	Filler Tray/Soap Tray
10.	Cabinet (LP)
	Cabinet (Standard)
	Cabinet (Floor Mounted)
	Power Supply
11.	Hardware Kit (Not Shown)

Part No.	Description
	MIXING VALVE
	MIX-135-A Below Deck Thermostatic Mixing Valve (BDT Variation)
	SENSOR REPLACEMENT KIT
	EL-1500-LL
	SOLENOID REPLACEMENT KIT
	ETF-1004-A
	SOLENOID FILTER REPLACEMENT KIT
	ETF-1009-A

SloanStone® EW-72000 Sink Head Assembly

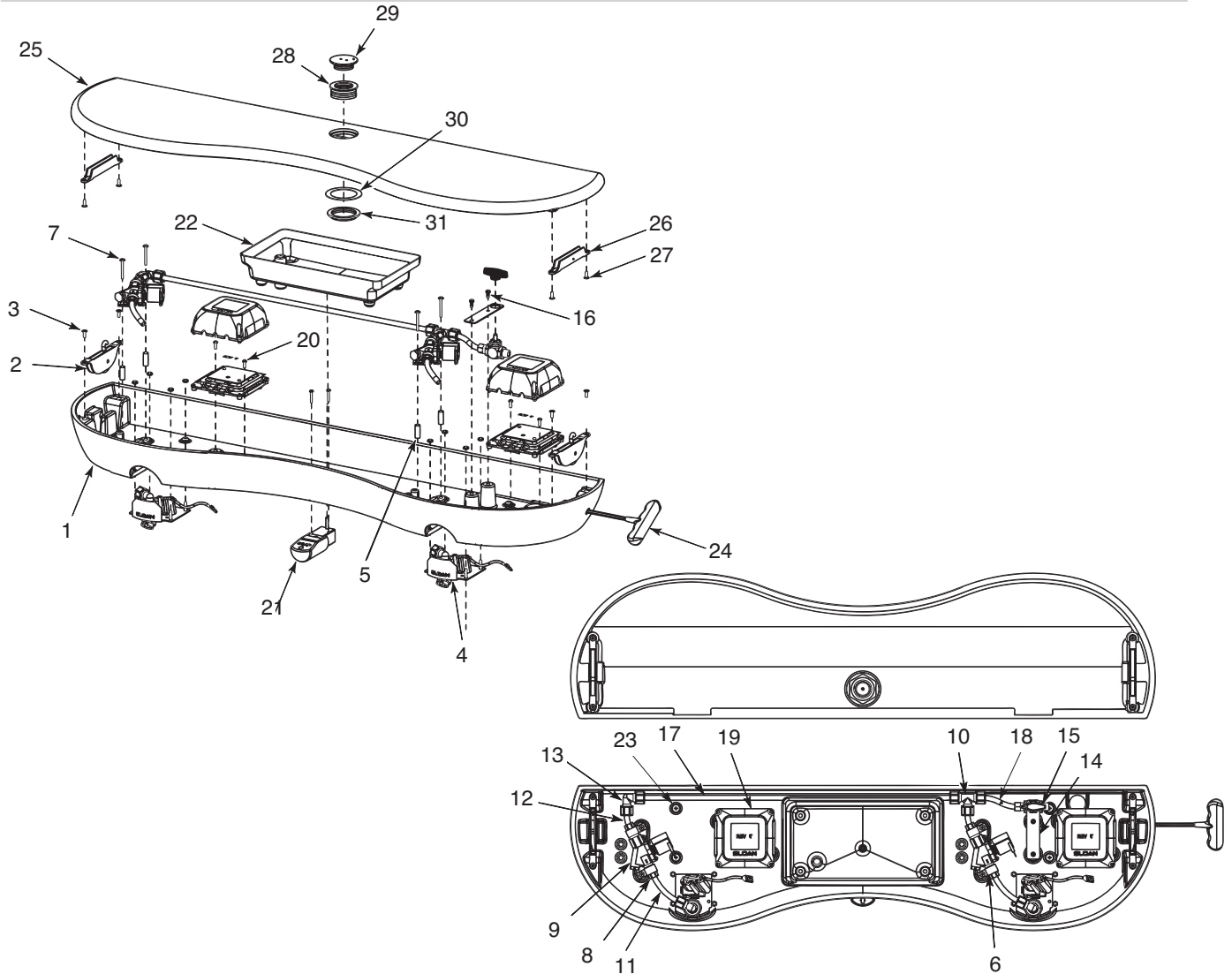

Item No.	Part No.	Description
1.	EW-46	Electronics Enclosure 2 Station Machined
2.	EW-41	Large Latch (2)
3.	EW-27	Screw, Flat Head #10-24 x 1/2" Long (4)
4.	EW-75-A	Sensor Plate Assembly (2)
5.	EW-8	Spacer, #8 x 1" Long (4)
6.	EW-13	Mounting Clamp for ETF-370-A Solenoid (4)
7.	EW-9	Screw, Truss Head #8-32 x 1-1/2" Long (4)
8.	ETF-61	Male Connector (4)
9.	ETF-370-A	Solenoid Valve Assembly (2)
10.	EW-19	Compression Tee Fitting 3/8" Tube
11.	EW-89-00362	Tube, 3/8" x 3-5/8" Long (2)
12.	EW-89-00188	Tube, 3/8" x 1-7/8" Long (2)
13.	EW-18	Compression Elbow Fitting, 3/8" Tube
14.	EW-5	Mounting Bracket for Shut-off Valve
15.	EW-74	Panel Mount Ball Valve - 3/8" Compression Fitting
16.	EW-36	Screw, Pan Head #8-32 x 7/16" Long (SEMS)(2)
17.	EW-89-02525	Tube, 3/8" x 25-1/4" Long
18.	EW-89-00388	Tube, 3/8" x 3-7/8" Long
19.	ETF-450-A	Splash Proof Junction Box Assembly (2)
20.	EW-28	Screw, Round Head #8-32 x 1/2" Long (4)
21. †	ESD-255-A	Manual Soap Pump Assembly

Item No.	Part No.	Description
22. †	ESD-245-A	Manual Soap Reservoir Assembly
23.	EW-37	Screw, Truss Head 1/4-20 x 1-1/2" (4)
—	EW-26	Tube Support 3/8" (5) (Not Shown)
—	MIX-135-A	Thermostatic Mixing Valve (Below Deck) (Not shown)
—	EW-87	Flexible Supply Hose, 2 Station (Not Shown)
—	EW-82-A	Wiring Harness, 2 Station (Not Shown)
—	ETF-233	Transformer (Not shown)
—	ETF-731	Vandal Proof Key, Standard and Junior (Not shown)
24.	EW-96	T-Handle Hex Wrench, 7/32"
25.	EW-48-X	Cover, Electronics Enclosure, 2 Station Machined
26.	EW-42	Large Encased Receiver (2)
27.	EW-27	Screw, Flat Head #10-24 x 1/2" Long (4)
28. ‡	ESD-242	Sleeve for Fill Cap
29. ‡	ESD-241	Fill Cap for Soap Reservoir
30. ‡	EW-11	Gasket - Fill Cap Sleeve (Manual Soap Reservoir)
31. ‡	ESD-243	Jam Nut for Fill Cap Sleeve
— ‡	ESD-249	Fill Cap Spanner (Not Shown)

† Included on models with Soap Dispenser.

‡ Included on models with Fill Cap.

SloanStone® EW-72000 Sink Cabinet and Basin Assembly

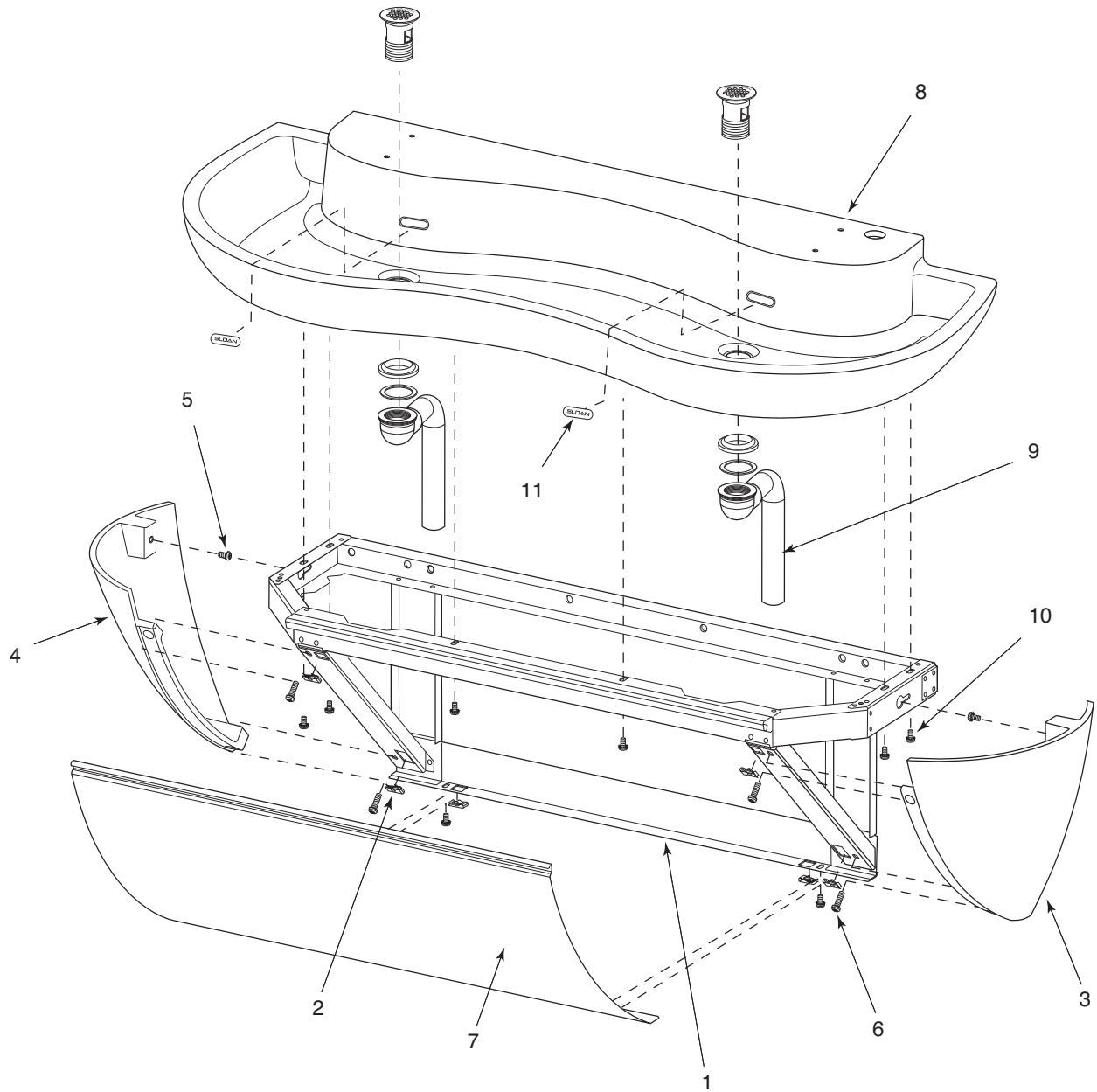

Item No.	Part No.	Description
1.	EW-20-A	Cabinet Weldment, 2 Station
2.	EW-99	U-Type Nut Standard 1/4-20 Thread (6)
3.	EW-60	End Cap Right - Machined
4.	EW-52	End Cap Left - Machined
5.	EW-15	Screw, Pan Head 1/4-20 x 1/2" Long (SEMS) (4)
6.	EW-16	Screw, Pan Head 1/4-20 x 1" Long (SEMS) (4)
7.	EW-25	Front Panel, 2 Station

Item No.	Part No.	Description
8.	EW-44	Basin 2-Station Machined
9.	ETF-725-A	Grid Strainer Assembly (2)
10.	EW-15	Screw, Pan Head 1/4-20 x 1/2" Long (SEMS) (6)
11.	EW-61	Overflow Cover Plate (2)
—	EW-98	Light Duty Buffing Pad (Not Shown)

SloanStone® EW-73000 Sink Cabinet and Basin Assembly

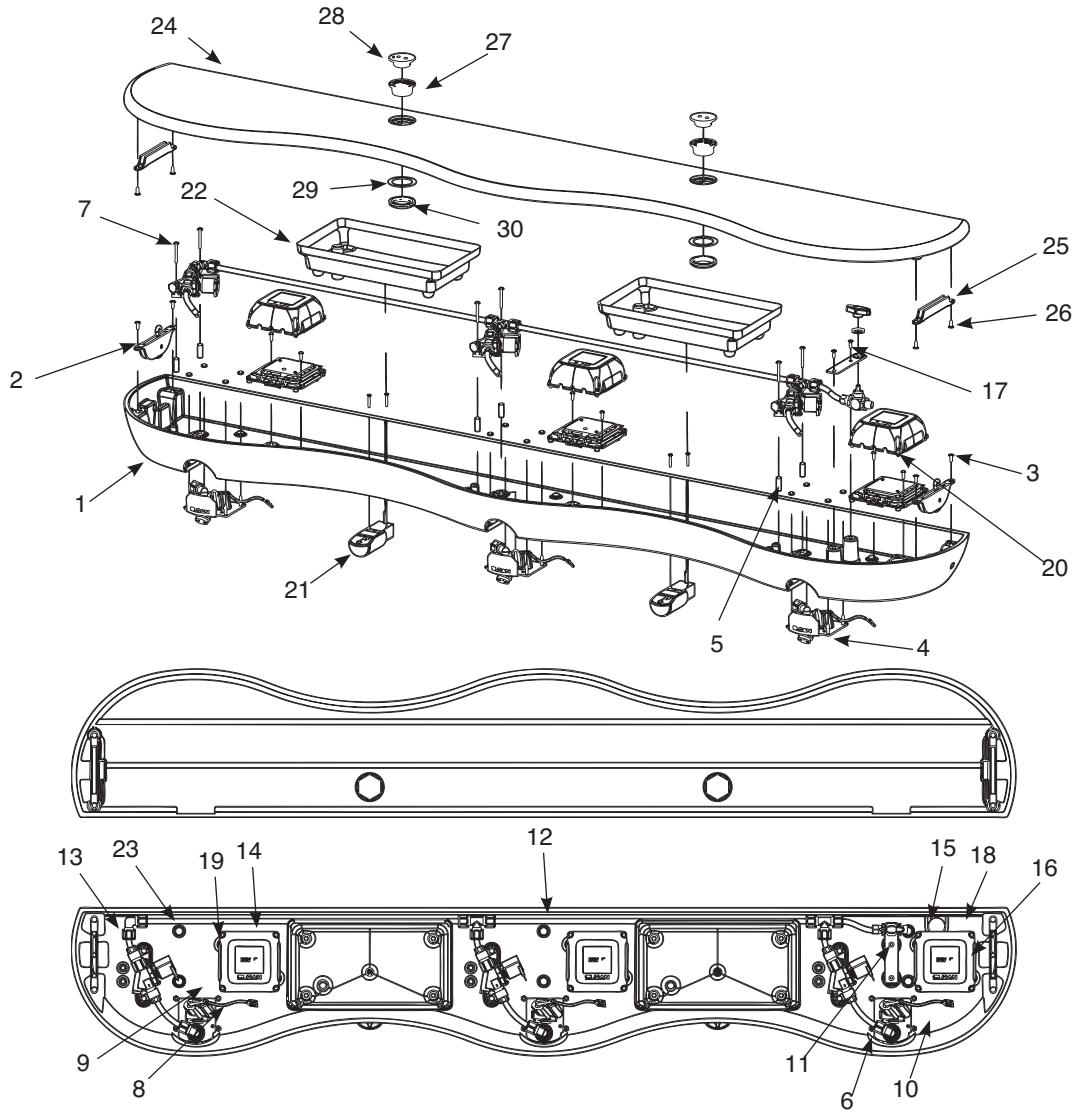

Item No.	Part No.	Description
1.	EW-56	Electronics Enclosure, 3 Station Machined
2.	EW-41	Large Latch (2)
3.	EW-27	Screw, Flat Head #10-24 x 1/2" Long (4)
4.	EW-75-A	Sensor Plate Assembly (3)
5.	EW-8	Spacer #8 x 1" Long (6)
6.	EW-13	Mounting Clamp ETF-370-A Solenoid (6)
7.	EW-9	Screw, Truss Head #8-32 x 1-1/2" Long (6)
8.	ETF-61	Male Connector (6)
9.	ETF-370-A	Solenoid Valve Assembly (3)
10.	EW-89-00362	Tube 3/8" x 3-5/8" Long (3)
11.	EW-89-00188	Tube 3/8" x 1-7/8" Long (3)
12.	EW-19	Compression Tee Fitting 3/8" Tube (2)
13.	EW-18	Compression Elbow Fitting 3/8" Tube
14.	EW-89-02525	Tube 3/8" x 25-1/4" Long (2)
15.	EW-89-00388	Tube 3/8" x 3-7/8" Long (1)
16.	EW-5	Mounting Bracket for Shut-off Valve
17.	EW-36	Screw, Pan Hd #8-32 x 7/16" Long (SEMS) (2)
18.	EW-74	Panel Mount Ball Valve - 3/8" Compression Fitting
19.	ETF-450-A	Splash Proof Junction Box Assembly (3)
20.	EW-28	Screw, Round Head #8-32 x 1/2" Long (6)
21. †	ESD-255-A	Manual Soap Pump Assembly (2)

Item No.	Part No.	Description
22. †	ESD-245-A	Soap Reservoir Assembly (2)
23.	EW-37	Screw, Truss Head 1/4-20 x 1-1/2" Long (6) (Not Shown)
—	EW-26	Tube Support 3/8" (7) (Not Shown)
—	MIX-135-A	Thermostatic Mixing Valve (Below Deck) (Not Shown)
—	EW-92-A	Wiring Harness 3 Station (Not Shown)
—	ETF-233	Transformer (Not Shown)
—	ETF-731	Vandal Proof Key, Standard and Junior (Not Shown)
—	EW-97	Flexible Supply Hose, 3 Station (Not Shown)
—	EW-96	T-Handle Hex Wrench 7/32" (Not Shown)
24.	EW-58-X	Cover, Electronics Enclosure, 3 Station Machined
25.	EW-42	Large Encased Receiver (2)
26.	EW-27	Screw, Flat Head #10-24 x 1/2" Long (4)
27. ‡	ESD-242	Sleeve for Fill Cap (2)
28. ‡	ESD-241	Fill Cap for Soap Reservoir (2)
29. ‡	EW-11	Gasket for Fill Cap Sleeve (2)
30. ‡	ESD-243	Jam Nut for Fill Cap Sleeve (2)
— ‡	ESD-249	Fill Cap Spanner (Not Shown)

† Included on models with Soap Dispenser.
‡ Included on models with Fill Cap.

SloanStone® EW-73000 Sink Head Assembly

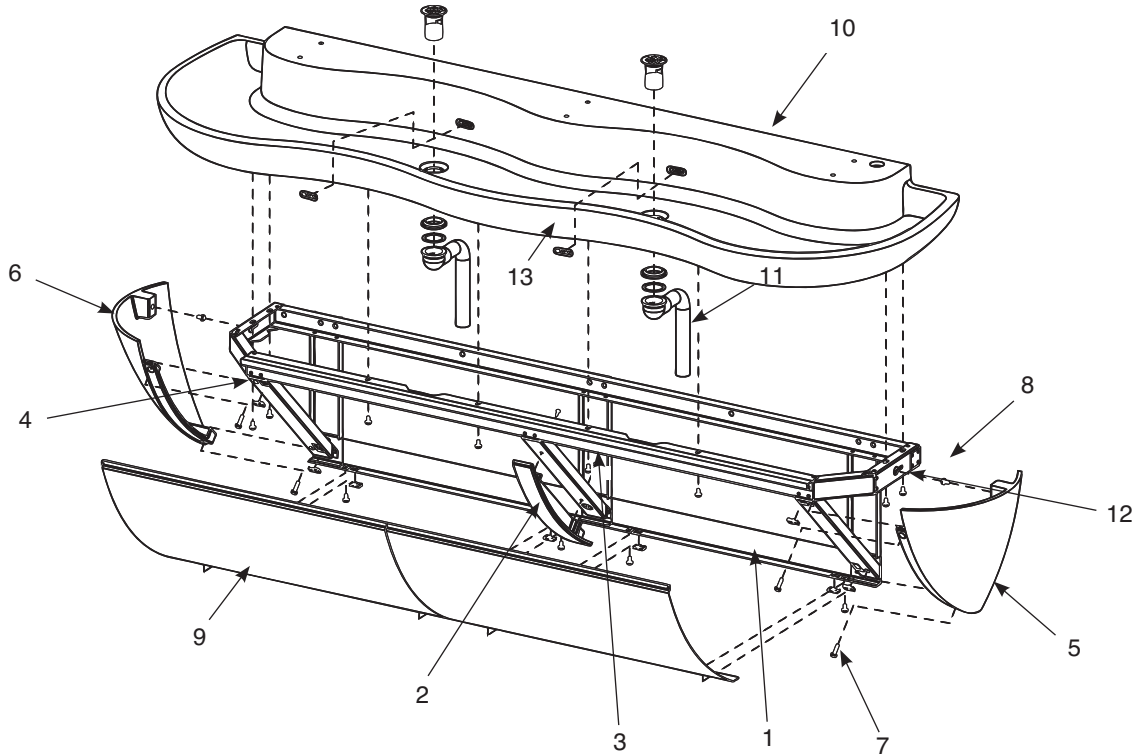

Item No.	Part No.	Description	Item No.	Part No.	Description
1.	EW-30-A	Cabinet Weldment, 3 Station	8.	EW-15	Screw, Pan Head 1/4-20 x 1/2" Long (SEMS) (2)
2.	EW-50	Front Panel Support - Machined	9.	EW-35	Front Panel, 3 Station (2)
3.	EW-36	Screw, Pan Head #8-32 x 7/16" Long (SEMS) (2)	10.	EW-54	Triple Station Lavatory Basin Assembly
4.	EW-99	U-type Nut, Standard 1/4-20 Thread (8)	11.	ETF-725-A	Grid Strainer Assembly (2)
5.	EW-60	End Cap Right - Machined	12.	EW-15	Screw, Pan Head 1/4-20 x 1/2" Long (SEMS) (8)
6.	EW-52	End Cap Left - Machined	13.	EW-61	Overflow Cover Plate (2)
7.	EW-16	Screw, Pan Head 1/4-20 x 1" Long (SEMS) (4)	—	EW-98	Light Duty Buffing Pad (Not Shown)

Troubleshooting Guide

1.No water flows when sensor is activated.

Ensure that main power supply is turned "ON." Check receptacle, transformer, solenoid, leads and connections.

If Sensor LED does not blink:

- A. Replace control module circuit board.
- B. Replace sensor module.

If Sensor LED blinks when user is sensed:

- A. Supply Stop(s) may be closed; open Supply Stop(s).
- B. Debris may be in Solenoid filter; remove, clean and reinstall.

2.Very low flow or slow dribble.

- A. Supply Stop(s) may be closed; open Supply Stop(s).
- B. Debris is in solenoid, won't close properly; remove operator and clean. Reassemble in the same manner.
- C. Debris is in Solenoid filter; remove, clean and reinstall.
- D. Debris is in spray head; remove, clean and reinstall.

3.Continues to run (even after power to faucet has been disconnected).

- A. Solenoid valve is installed backwards; install correctly.
- B. Debris is in solenoid, won't close properly; remove operator and clean. Reassemble in the same manner.

SloanStone® EW-62000 Sink

Top Level Assembly

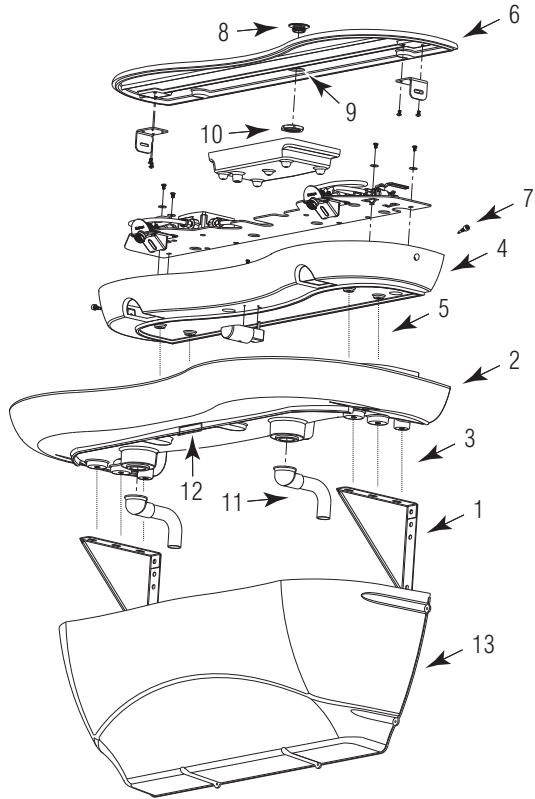

EW-62000 Double Station Cables

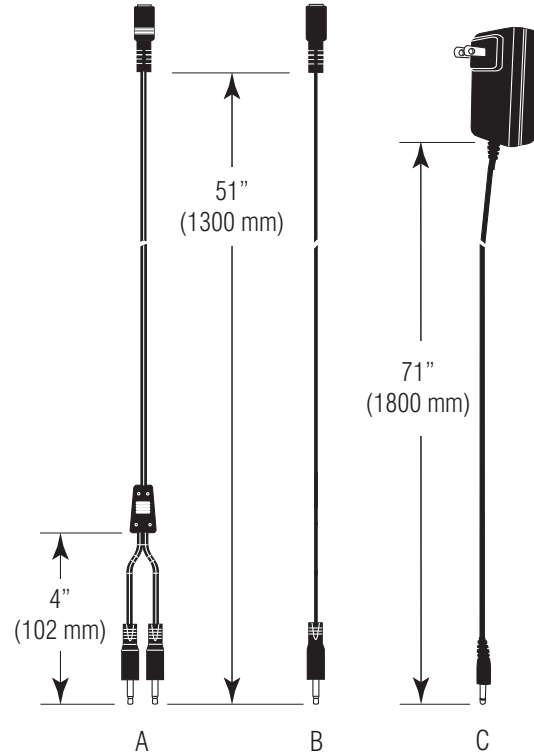

Item No.	Part No.	Description
1.	EW-122	Mounting Bracket (2)
2.	EW-129	Basin
3.	ELC-41	Screw, Machine Truss Head 1/4-20 (6)
4.	EW-135-A	Head
†	EW-142-A	Head with Manual Soap Dispenser
5.	EW-37	Screw, Truss Head 1/4-20 x 1-1/2" Long (4)
6.	EW-130-A	Cover
‡	EW-138-A	Cover with Fill Cap
7.	EW-115	Cover Attachment Screw
8. ‡	ESD-241	Fill Cap for Soap Reservoir
9. ‡	ESD-242	Sleeve for Fill Cap
10. ‡	ESD-243	Jam Nut for Fill Cap Sleeve
11.	ETF-725-A	Grid Strainer Assembly (2)
12.	EW-127	Velcro® Strip (Hook)
13.	EW-105	Plastic Cabinet
—	MIX-19	Supply Hose (Not Shown)
—	EW-96	T-Handled Wrench (Not Shown)
—	EW-128	Velcro® Strip (Loop) (Not Shown)
— ‡	ESD-249	Fill Cap Spanner (Not Shown)
—	EW-98	Light Duty Buffing Pad (Not Shown)
—	EW-108	General Purpose Buffing Pad (Not Shown)
†	EW-141	Spacers (Not Shown)

† Included on models with Soap Dispenser

‡ Included on models with Fill Cap

Item No.	Part No.	Description
A.	SFP-38	Cable Splitter
B.	SFP-37	Cable Extension
C.	SFP-36	Transformer

SloanStone® EW-62000 Sink

Electronic Components

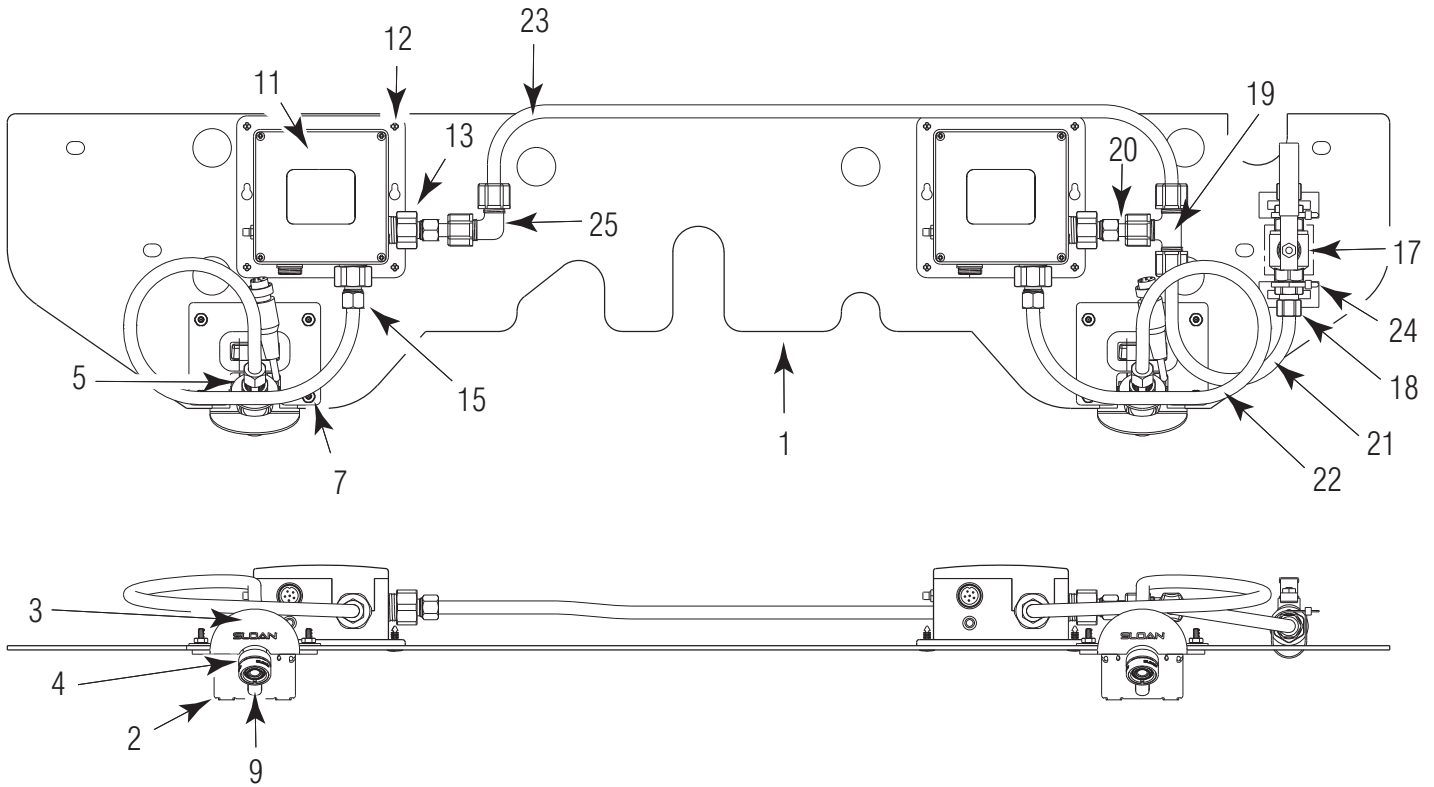
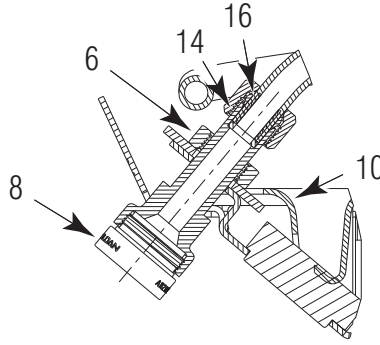

Item No.	Part No.	Description
1.	EW-113	Component Mounting Plate, 2 Station
2.	EW-119	Sensor Housing
3.	EW-100-A	Sensor Base Plate Assembly
4.	EW-112	Spout Adapter
5.	EW-140	Washer, 9/16"
6.	MIX-69	Hex Nut
7.	EW-14	Nut #8-32 (KEPS)
8.	ETF-723	Spray Head 0.5 gpm (1.9 Lpm) Vandal Proof
9.	SFP-41-A	Sensor with Range Adjustment Kit
10.	EW-120	Sensor Backing Piece
11.	SFP-40	Control Box with Button
12.	EW-116	Push-In Clip
13.	SFP-45-A	Inlet Adapter Kit

Item No.	Part No.	Description
14.	EW-26	Tube Support 3/8"
15.	ETF-209	Compression Nut
16.	ETF-208	Ferrule
17.	EW-118	Shut-Off Valve
18.	ETF-61	Male Connector
19.	EW-19	Compression Tee Fitting 3/8" Tube
20.	EW-89-1	Tube, 3/8" 1.56" (40 mm) Long
21.	EW-89-6	Tube, 3/8" 8.19" (208 mm) Long
22.	EW-89-7	Tube, 3/8" 17.50" (445 mm) Long
23.	EW-89-10	Tube, 3/8" 24.75" (629 mm) Long
24.	ETF-198	Tie Wrap
25.	EW-18	Compression Elbow Fitting 3/8" Tube
—	ELC-17	Bond Tape (Not Shown)

SloanStone® EW-63000 Sink

Top-level Assembly

EW-63000 Double Station Cables

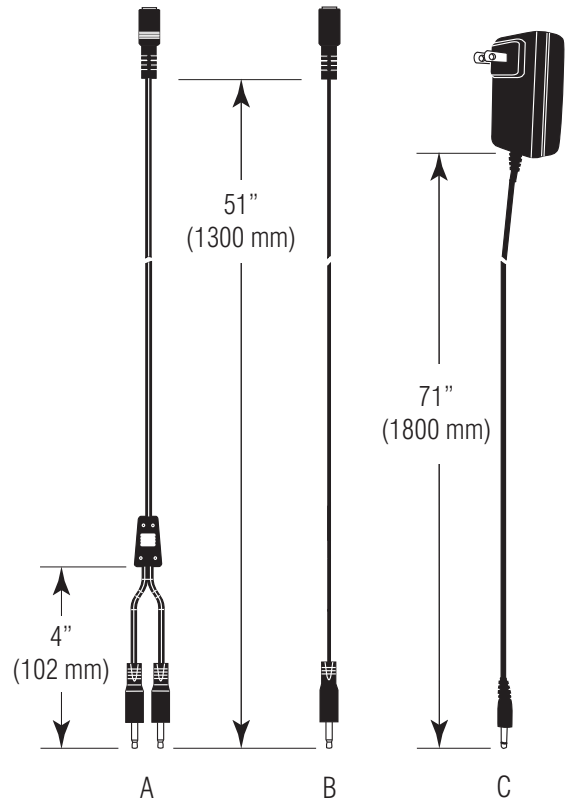
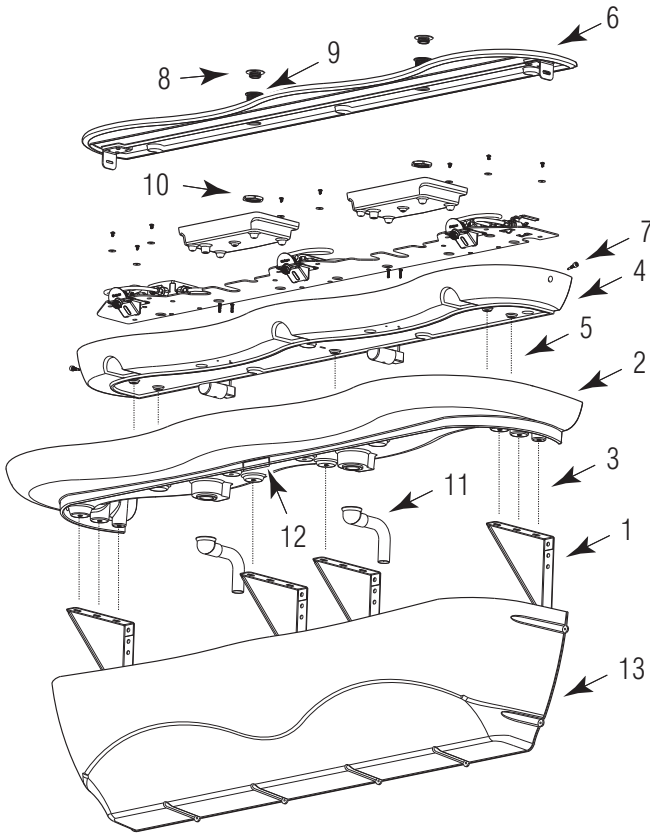

Item No.	Part No.	Description
1.	EW-122	Mounting Bracket (4)
2.	EW-134	Basin
3.	ELC-41	Screw, Machine Truss Head 1/4-20 (8)
4.	EW-136-A	Head
†	EW-143-A	Head with Manual Soap Dispenser
5.	EW-37	Screw, Truss Head 1/4-20 x 1-1/2" Long (5)
6.	EW-137-A	Cover
‡	EW-139-A	Cover with Fill Cap
7.	EW-115	Cover Attachment Screw (2)
8.	‡ ESD-241	Fill Cap for Soap Reservoir
9.	‡ ESD-242	Sleeve for Fill Cap
10.	‡ ESD-243	Jam Nut for Fill Cap Sleeve
11.	ETF-725-A	Grid Strainer Assembly (2)
12.	EW-127	Velcro® Strip (Hook)
13.	EW-123	Plastic Cabinet
—	MIX-19	Supply Hose (Not Shown)
—	EW-96	T-Handled Wrench (Not Shown)
—	EW-128	Velcro® Strip (Loop) (Not Shown)
—	‡ ESD-249	Fill Cap Spanner (Not Shown)
—	EW-98	Light Duty Buffing Pad (Not Shown)
—	EW-108	General Purpose Buffing Pad (Not Shown)
†	EW-141	Spacers (Not Shown)
† Included on models with Soap Dispenser		
‡ Included on models with Fill Cap		

Item No.	Part No.	Description
A.	SFP-38	Cable Splitter
B.	SFP-37	Cable Extension
C.	SFP-36	Transformer

SloanStone® EW-63000 Sink

Electronic Components

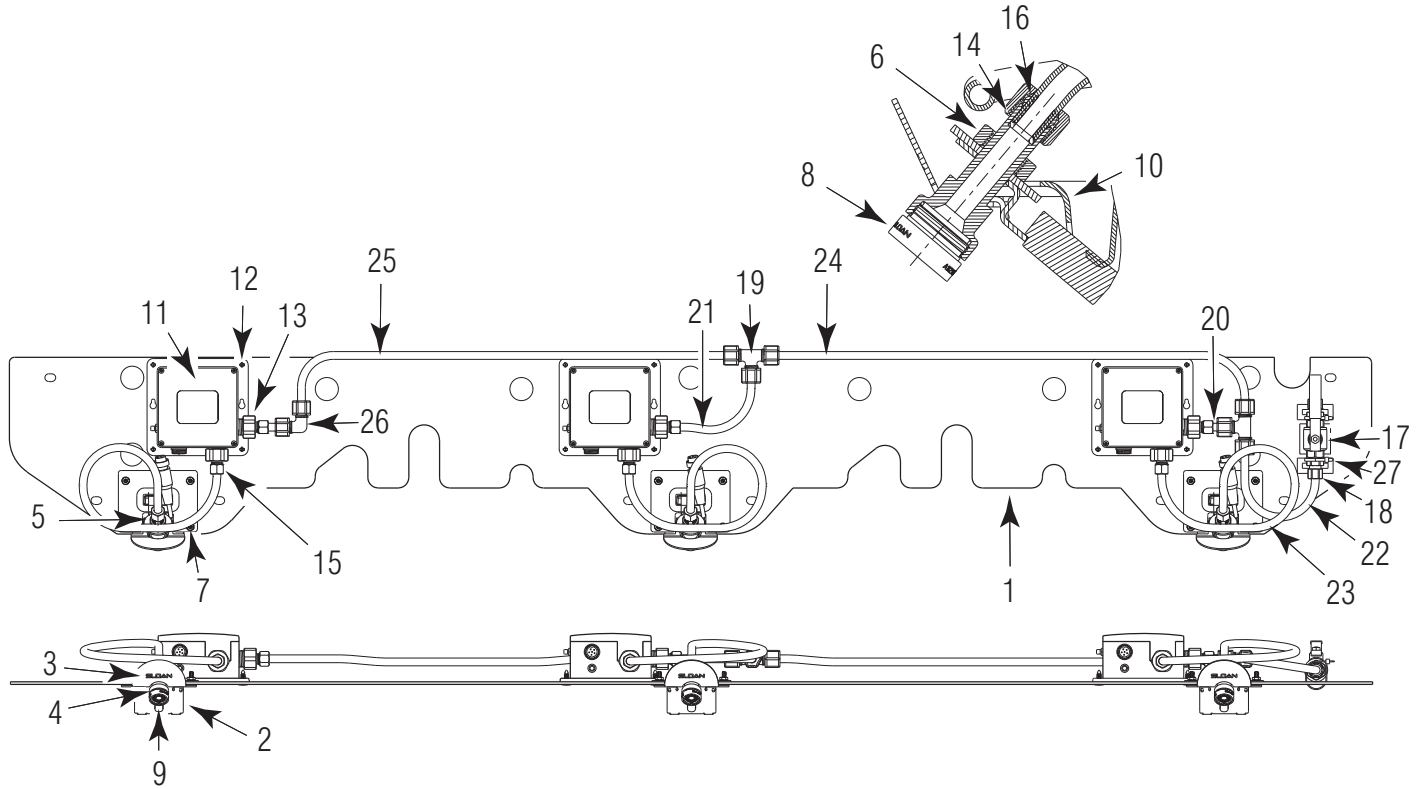

Item No.	Part No.	Description
1.	EW-117	Component Mounting Plate, 3 Station
2.	EW-119	Sensor Housing
3.	EW-100-A	Sensor Base Plate Assembly
4.	EW-112	Spout Adapter
5.	EW-140	Washer, 9/16"
6.	MIX-69	Hex Nut
7.	EW-14	Nut #8-32 (KEPS)
8.	ETF-723	Spray Head 0.5 gpm (1.9 Lpm) Vandal Proof
9.	SFP-41-A	Sensor with Range Adjustment Kit
10.	EW-120	Sensor Backing Piece
11.	SFP-40	Control Box with Button
12.	EW-116	Push-In Clip
13.	SFP-45-A	Inlet Adapter Kit
14.	EW-26	Tube Support 3/8"

Item No.	Part No.	Description
15.	ETF-209	Compression Nut
16.	ETF-208	Ferrule
17.	EW-118	Shut-Off Valve
18.	ETF-61	Male Connector
19.	EW-19	Compression Tee Fitting 3/8" Tube
20.	EW-89-1	Tube, 3/8" 1.56" (40 mm) Long
21.	EW-89-5	Tube, 3/8" 6.75" (172 mm) Long
22.	EW-89-6	Tube, 3/8" 8.19" (208 mm) Long
23.	EW-89-7	Tube, 3/8" 17.50" (445 mm) Long
24.	EW-89-9	Tube, 3/8" 25.75" (654 mm) Long
25.	EW-89-10	Tube, 3/8" 24.75" (629 mm) Long
26.	EW-18	Compression Elbow Fitting 3/8" Tube
27.	ETF-198	Tie Wrap
—	ELC-17	Bond Tape (Not Shown)

SloanStone® EW-62000/63000 Sinks

Troubleshooting

1. Faucet delivers water in an uncontrolled manner.

- A. Contact Sloan Technical Support at +1.888.756.2614.

2. Faucet does not deliver any water when Sensor is activated.**INDICATOR: Solenoid valve produces an audible “CLICK.”**

- A. Water supply stop(s) closed. Open water supply stop(s).
- B. Water strainer in control module is clogged. Close supply stops and remove water inlet line at control module. Remove, clean and reinstall strainer and water inlet line. Replace strainer if required.

INDICATOR: Solenoid valve DOES NOT produce an audible “CLICK.”

- A. Batteries low (battery powered models). Replace batteries.
- B. Power failure (transformer powered models). Check power supply.

3. Faucet delivers only a slow flow or dribble when Sensor is activated.

- A. Water supply stop(s) are partially closed. Completely open water supply stop(s).
- B. Water strainer in control module is clogged. Close supply stops and remove water inlet line at control module. Remove, clean and reinstall strainer and water inlet line. Replace strainer if required.
- C. Aerator is clogged. Remove, clean, and reinstall aerator. Replace aerator if required.

4. Faucet does not stop delivering water or continues to drip after user is no longer detected.

- A. Contact Sloan Technical Support at +1.888.756.2614.

5. The water temperature is too hot or too cold when connected to hot and cold supply lines.

- A. Mixing Valve is not adjusted properly. Adjust Mixing Valve.

6. Solenoid Valve does not produce an audible “CLICK” after plugging transformer into live receptacle (transformer powered models).

- A. Unplug Transformer from receptacle. Wait one minute. Check that all connections to Control Modules are properly made. Plug Transformer back into live receptacle.

SloanStone® ELS-62000 Sink
Cabinet and Basin Assemblies

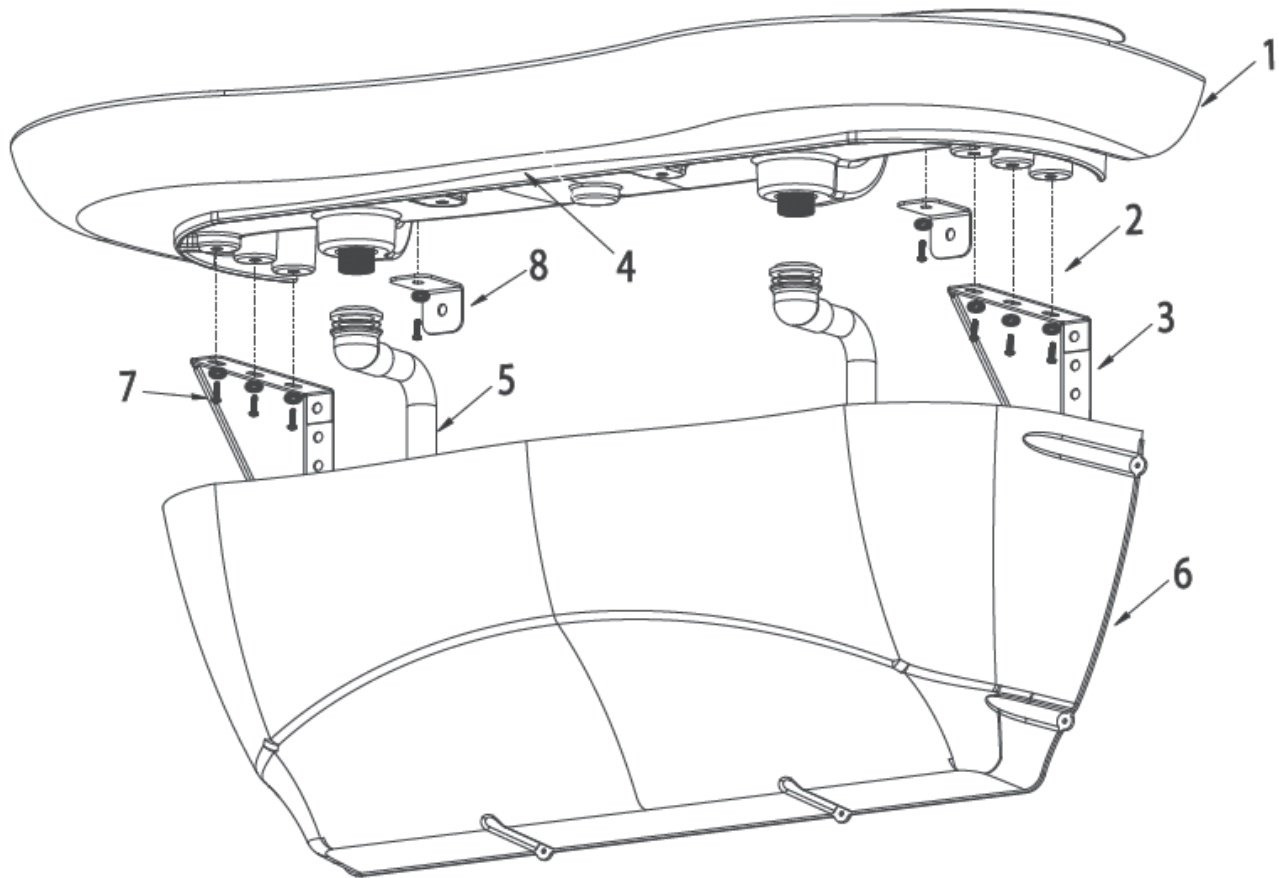

Item No.	Part No.	Description
1.	SEE TABLE	Double Station Lavatory Basin Assembly
2.	ELC-41	Screw, Machine Truss Head 1/4-20 (8)
3.	EW-122	Mounting Bracket (2)

Item No.	Part No.	Description
4.	EW-127	Velco Strip (Hook)
5.	ETF-725-A	Grid Strainer Assembly (2)
6.	EW-105	Plastic Cabinet for Double Station Lavatory
7.	EW-157	Washers (8)
	EW-98	Light Duty Buffing Pad (Not Shown)
	EW-108	General Duty Buffing Pad (Not Shown)

ITEM NO. 1 – Double Station Lavatory Basin Hole Patterns

Hole Pattern	–	A	B	C	D
Part No.	ELS-9-A-XXX	ELS-9-A-XXX-A	ELS-9-A-XXX-B	ELS-9-A-XXX-C	ELS-9-A-XXX-D
Basin Hole Pattern					

SloanStone® ELS-63000 Sink

Cabinet and Basin Assemblies

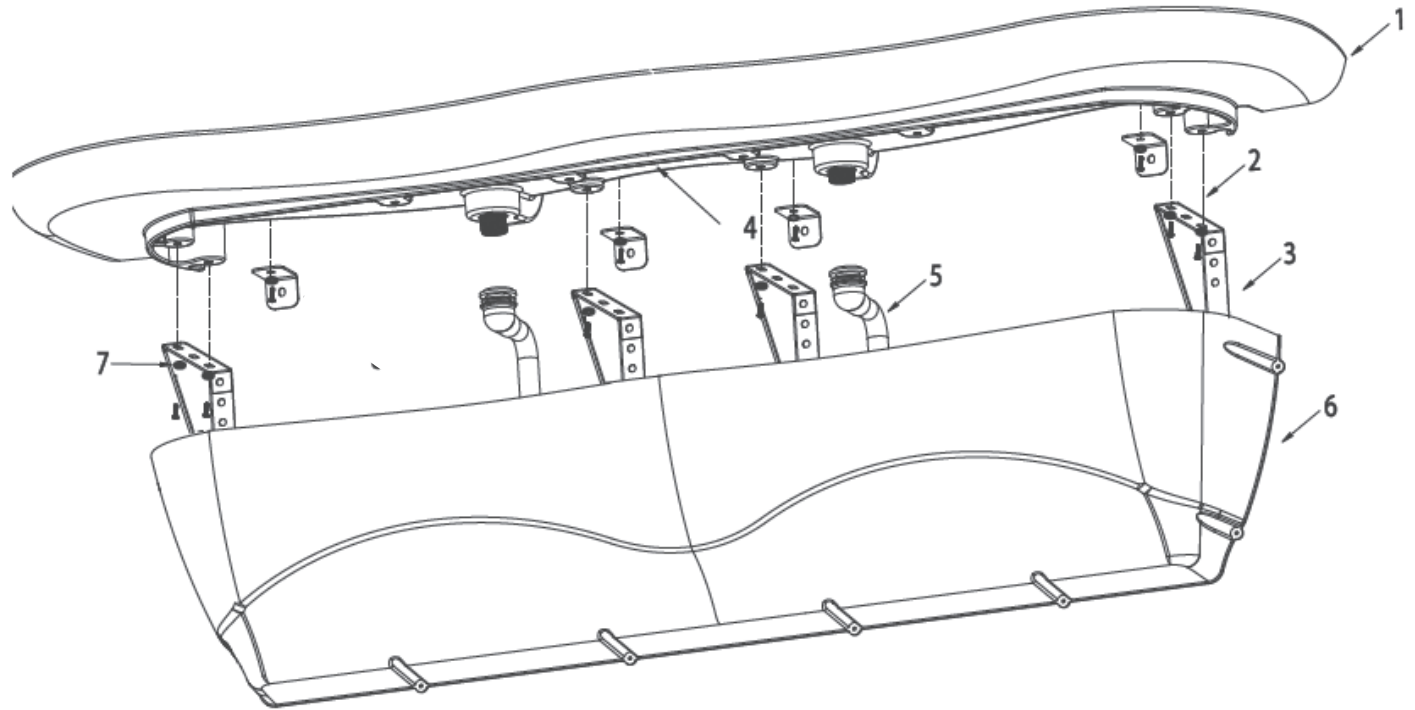

Item No.	Part No.	Description
1.	SEE TABLE	Triple Station Lavatory Basin
2.	ELC-41	Screw, Machine Truss Head 1/4-20 (10)
3.	EW-122	Mounting Bracket (4)
4.	EW-127	Velcro Strip (Hook)

Item No.	Part No.	Description
5.	ETF-725	Grid Strainer Assembly (2)
6.	EW-123	Plastic Cabinet for Triple Station Lavatory
7.	EW-157	Washers (10)
—	EW-98	Light Duty Buffing Pad (Not Shown)
—	EW-108	General Duty Buffing Pad (Not Shown)

ITEM NO. 1 – Triple Station Lavatory Basin Hole Patterns

Hole Pattern	—	A	B	C	D
Part No.	ELS-11-A-XXX	ELS-11-A-XXX-A	ELS-11-A-XXX-B	ELS-11-A-XXX-C	ELS-11-A-XXX-D
Basin Hole Pattern					

SloanStone® ELS-72000 Sink

Cabinet and Basin Assemblies

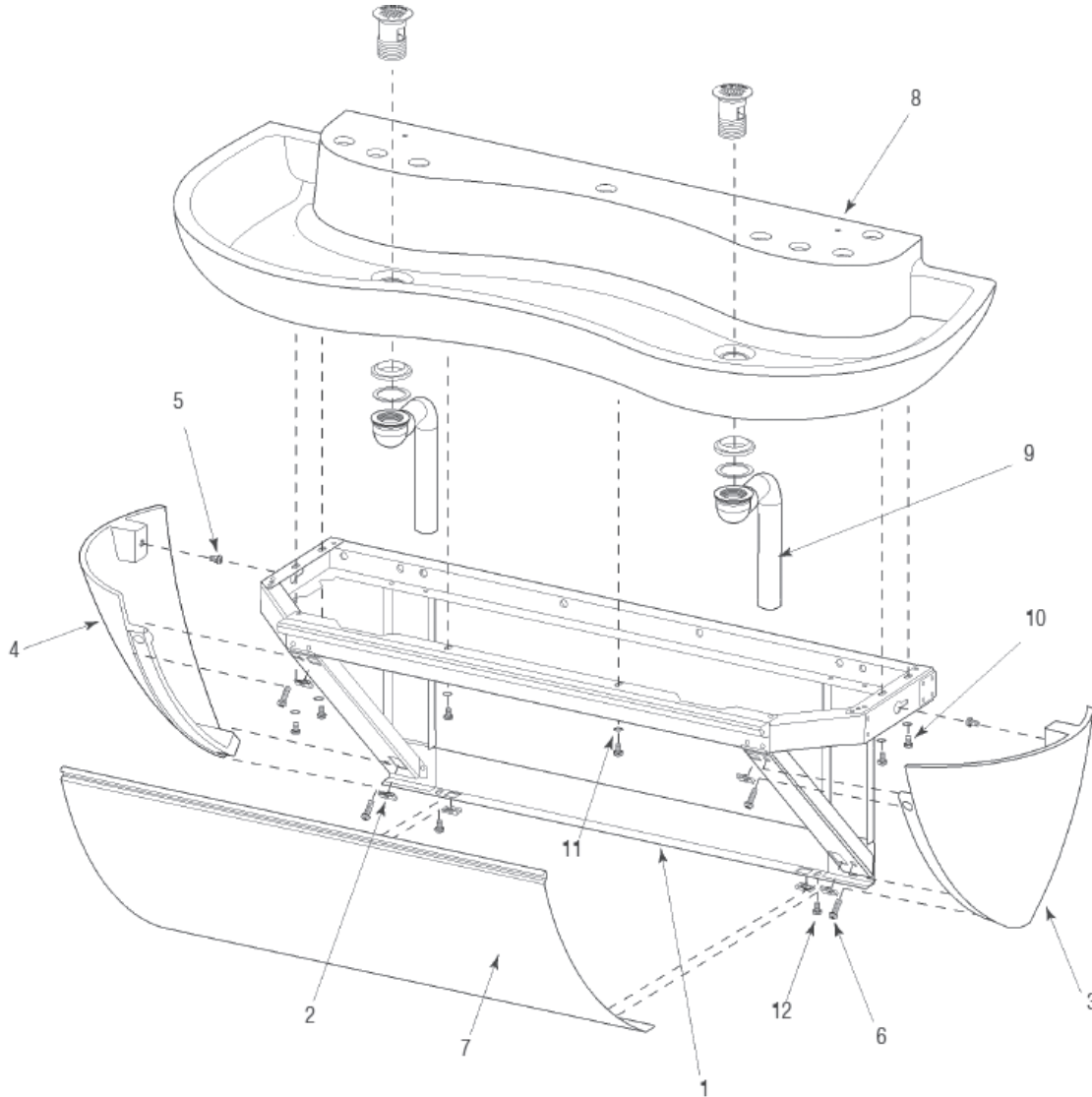

Item No.	Part No.	Description
1.	EW-20-A	Cabinet Weldment, 2 Station
2.	EW-99	U-Type Nut Standard 1/4-20 Thread (6)
3.	EW-60	End Cap Right-Machined
4.	EW-52	End Cap Left-Machined
5.	EW-15	Screw Pan Head 1/4-20 x 1/2" Long (SEMS) (2)
6.	EW-16	Screw Pan Head 1/4-20 x 1" Long (SEMS) (4)
7.	EW-25	Front Panel, 2 Station

Item No.	Part No.	Description
8.	SEE TABLE	Double Station lavatory Basin Assembly
9.	ETF-725-A	Grid Strainer Assembly (2)
10.	ELC-41	Screw, Truss Head 1/4 - 20 x 1/2" Long (6)
11.	EW-157	Washer (6)
12.	EW-15	Screw, Pan Head 1/4-20x1/2" Long (SEMS)(2)
	EW-98	Light Duty Buffing pad (Not Shown)
	EW-108	General Duty Buffing Pad (Not Shown)

ITEM NO. 8 — Double Station Lavatory Basin Hole Patterns

Hole Pattern	—	A	B	C	D
Part No.	ELS-9-A-XXX	ELS-9-A-XXX-A	ELS-9-A-XXX-B	ELS-9-A-XXX-C	ELS-9-A-XXX-D
Basin Hole Pattern					

SloanStone® ELS-73000 Sink
Cabinet and Basin Assemblies

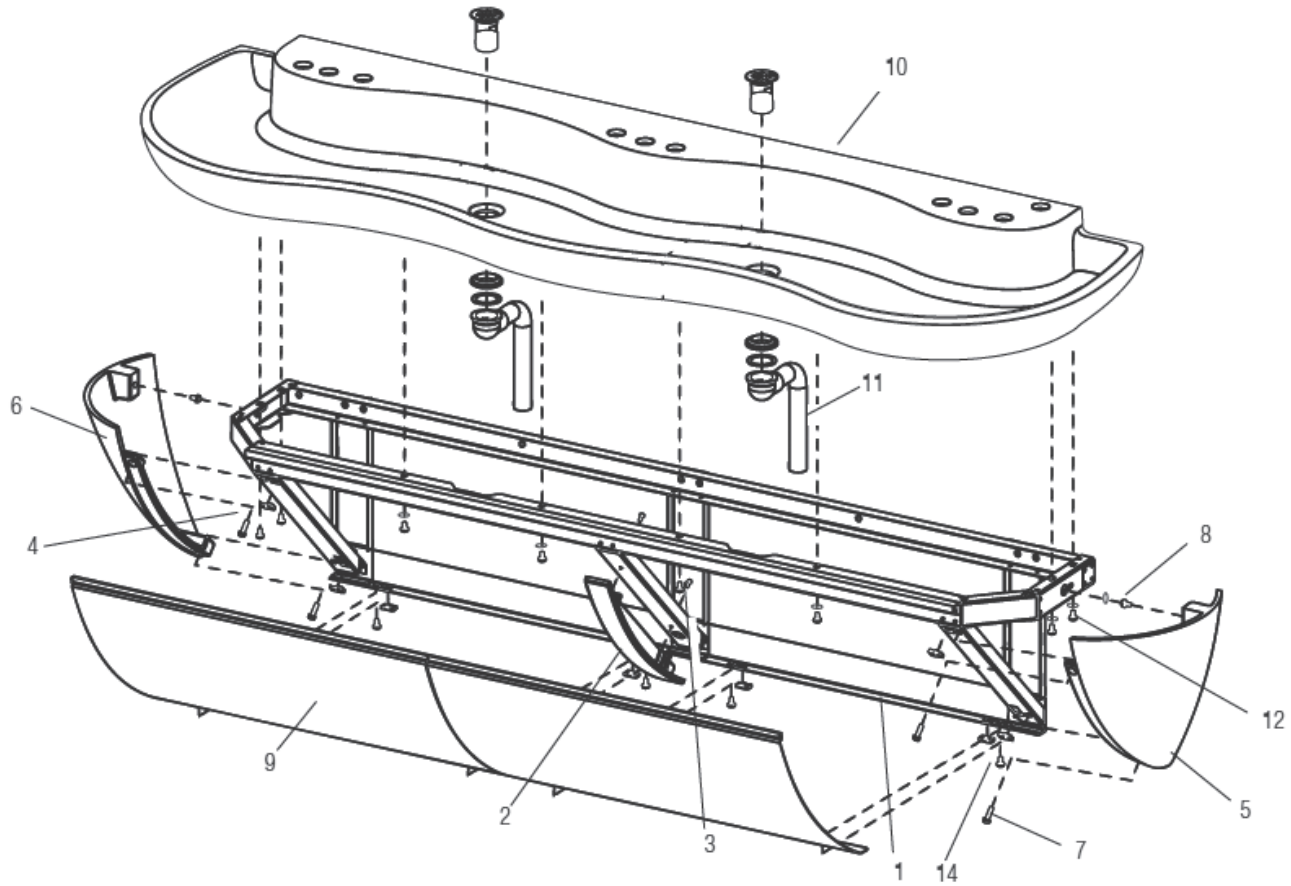

Item No.	Part No.	Description
1.	EW-149	Cabinet Weldment, 3 Station
2.	EW-50	Front Panel Support-Machined
3.	EW-36	Screw Pan Head #8-32 x 7/16" Long (SEMS) (2)
4.	EW-99	U-Type Nut, Standard 1/4-20 Thread (8)
5.	EW-60	End Cap Right-Machined
6.	EW-52	End Cap Left-Machined
7.	EW-16	Screw Pan Head 1/4-20 x 1" Long (SEMS) (4)
8.	EW-15	Screw Pan Head 1/4-20 x 1/2" Long (SEMS) (2)

Item No.	Part No.	Description
9.	EW-155	Front Panel, 3 Station (2)
10.	SEE TABLE	Triple Station Lavatory Basin Assembly
11.	ETF-725-A	Grid Strainer Assembly (2)
12.	ELC-41	Screw, Truss Head 1/4-20 x 1/2" Long (8)
13.	EW-157	Washer (8)
14.	EW-15	Screw Pan Head 1/4-20 x 1/2" Long (SEMS) (4)
	EW-98	Light Duty Buffing Pad (Not Shown)
	EW-108	General Duty Buffing Pad (Not Shown)

Hole Pattern	—	A	B	C	D
Part No.	ELS-11-A-XXX	ELS-11-A-XXX-A	ELS-11-A-XXX-B	ELS-11-A-XXX-C	ELS-11-A-XXX-D
Basin Hole Pattern					

BIO DECK ELB-51000/ELB-52000 Sinks
DISCONTINUED

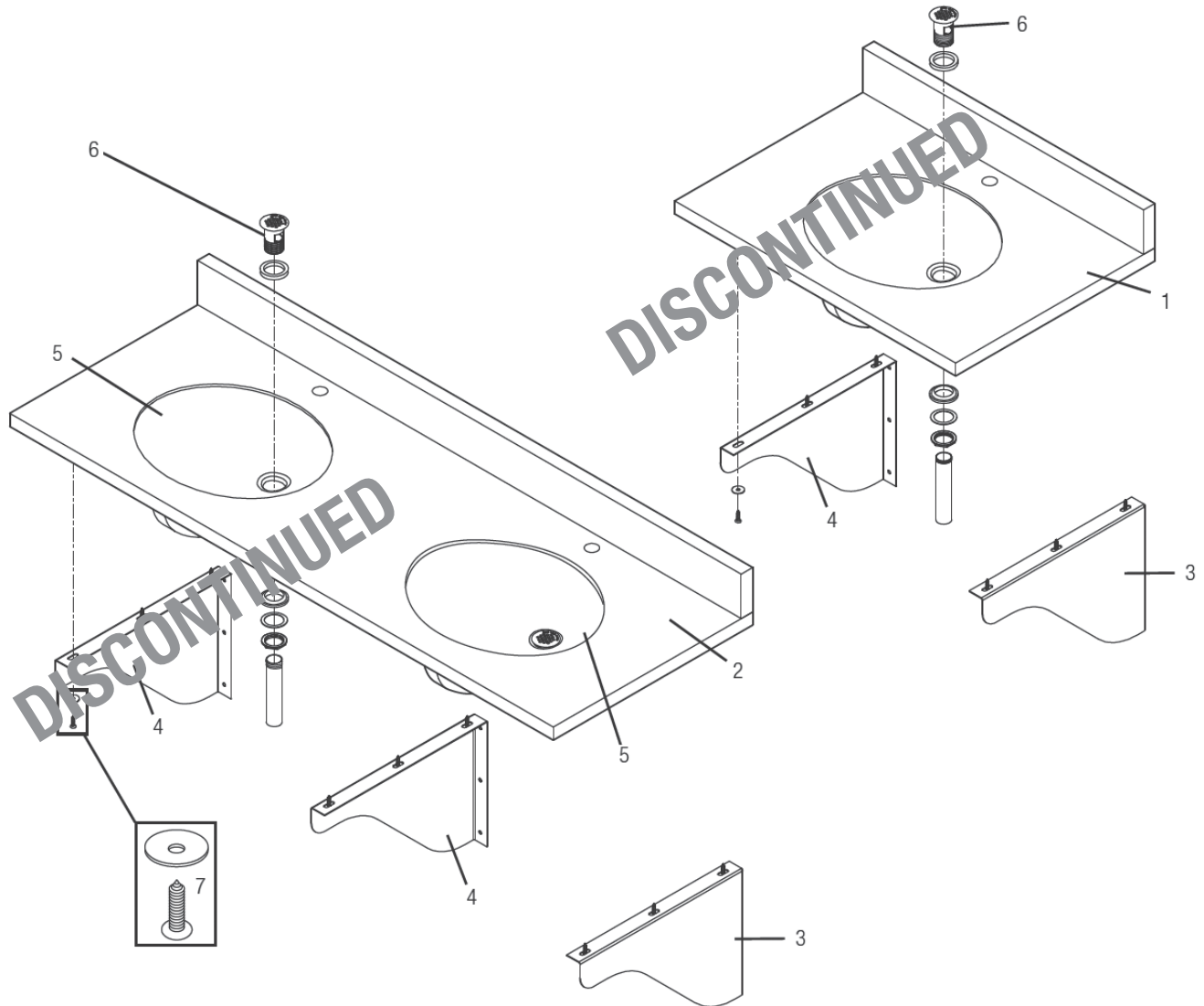

Item No.	Part No.	Description
1.	ELB-51000	Bio-Deck Surface-Single Station
2.	ELB-52000	Bio-Deck Surface-Double Station
3.	ELB-3	Right Mounting Bracket (Optional)
4.	ELB-4	Left Mounting Bracket (Optional)

Item No.	Part No.	Description
5.	SS-7	Vitreous China Undermount Sink
9.	ETF-460-A	Grid Strainer Assembly
10.	ELB-7-A	Mounting Hardware includes 1/4" Fender Washer and 1/4" x 1" Sheet Metal Screw Sloan Faucet Model Varies

BIO DECK ELB-51000/ELB-52000 Sinks DISCONTINUED

TROUBLESHOOTING GUIDE

Refer to appropriate faucet pages in Maintenance Guide.

1. No water flows when sensor is activated

Ensure that main power supply is turned "ON." Check receptacle, transformer, batteries (battery powered models), solenoid, leads and connections.

INDICATOR: If Sensor LED does not blink:

- A. Control module circuit board is faulty; replace.
- B. Sensor is faulty; replace sensor module.

INDICATOR: If Sensor LED blinks when user is sensed:

- A. Supply Stop(s) may be closed; open Supply Stop(s).
- B. Debris may be in Solenoid filter; remove, clean and reinstall.

2. Very low flow or slow dribble

- A. Supply Stop(s) may be closed; open Supply Stop(s).
- B. Debris is in solenoid, won't close properly; remove operator and clean. Reassemble in the same manner.
- C. Debris may be in Solenoid filter; remove, clean and reinstall.
- D. Debris is in aerator; remove, clean and reinstall.

3. Continues to run (even after power to faucet has been disconnected)

- A. Solenoid valve is installed backwards; install correctly.
- B. Debris is in solenoid, won't close properly; remove operator and clean. Reassemble in the same manner.

Solenoid Screen Filter Cleaning

- A. Before cleaning the Screen Filter, turn off the water supply at supply stop(s).
- B. Activate the Faucet to relieve any pressure in the system.
- C. Unscrew the Filter Cap and remove it from the Solenoid Valve Housing.
- D. Carefully remove the Screen Filter from the Solenoid Valve Housing.
- E. Clean the Screen Filter using fresh tap water only. If necessary, use a small brush to clean. Use caution while cleaning to prevent damage to Screen Filter.
- F. Examine the Copper Washer or O-ring for wear or damage; replace if necessary. Carefully replace the Screen Filter into Filter Cap. Screw the Filter Cap with Copper Washer or O-ring into Solenoid Valve Housing and tighten securely to prevent leaks.
- G. Turn on the water supply at the supply stop(s). Activate the Faucet to purge any air from the system lines. Check for leaks and repair as necessary.

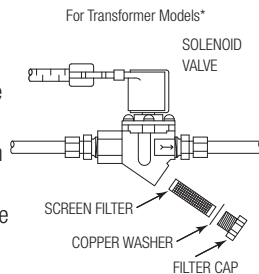

SloanStone® Solid Surface Care

For normal cleaning, use warm, soapy water or conventional ammonia based liquid glass cleaner.

For dry stains, allow the soapy water or glass cleaner some time to re moisturize the area, then wipe the stain off.

To renew the surface after deep scratches or stains, use green, then maroon, and finally white 3M Scotch-Brite® pads to return the deck to a smooth 1200 grit wet-sanded finish.

If the dry stain is neither water-based nor oil-based, gently scrape the stain off with a plastic material (i.e. a plastic knife), and then proceed with the aforementioned normal cleaning procedures.

Wipe the entire surface evenly with a mild abrasive cleanser for regular maintenance.

Stainless Steel Care

Important: When cleaning stainless steel, always rub in the same direction of the stainless steel finish lines, never across. After cleaning, always thoroughly rinse with water and dry all cleaned stainless steel areas to prevent buildup of mineral deposits.

Clean stainless steel surfaces often using warm, soapy water.

For more stubborn deposits, use baking soda, borax or any of several non-abrasive commercial cleansing agents. Do not leave chlorides found in most cleansing agents for extended periods of time on the surfaces as they may attack stainless steel. If an abrasive cleaning tool is needed, always use stainless steel wool, stainless steel pads, or stainless steel brushes. Do not use ordinary steel wool, pads or brushes because they have a tendency to break apart and leave small particles which will rust on the stainless steel surfaces, giving the appearance that the stainless steel surfaces themselves are rusting. Do not use strong acidic or caustic cleaners or cleansers because they may also attack the stainless steel surfaces. Maintain a regular cleaning schedule.

**When assistance is required, please contact
Sloan Technical Support at: 1-888-SLOAN-14 (1-888-756-2614).**

Designer Series™ DSG-80000 and DSOF-80000 Sinks

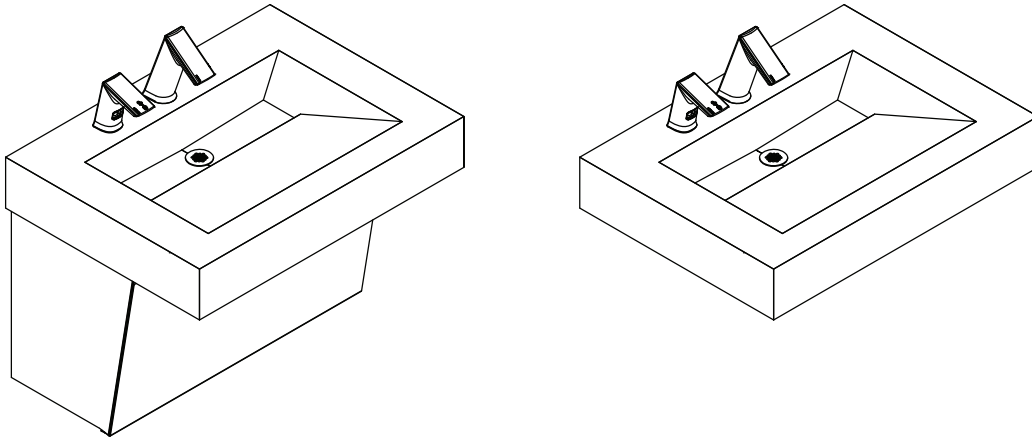

Sink Location

Determine the appropriate wall location for the Lavatory System. Consider that hot and cold water supply lines, a drain line, and an electrical source (receptacle for hardwired faucets and hand dryer) will be required. Compare the physical dimensions of the Lavatory System to the space available for the installation. If wall is not load bearing, a carrier may be required behind the wall. Refer to the appropriate Rough-in diagrams for Lavatory System dimensions. Prior to Lavatory System installation, electric wiring, water supply and drain must be installed.

DSG-81000, One Station Components

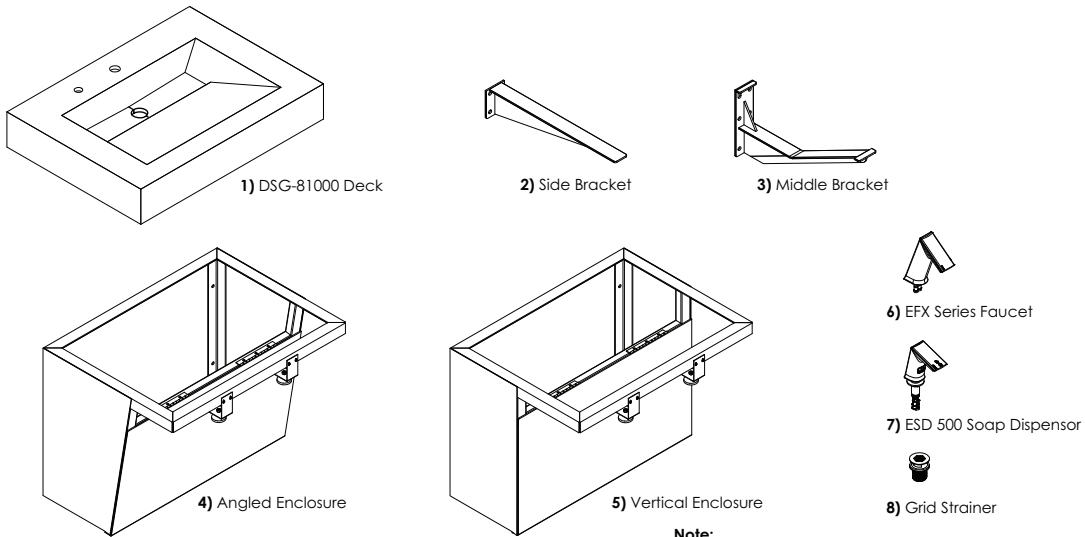

Note:
Faucet and Soap dispenser models shown for reference, actual units will depend on what was selected at order entry.

DSG-81000, One Station Component List

Description	Item Number	Quantity
Designer Series Gradient, One Station, Deck	1	1
Side Bracket (Mounting Option)	2	2
Middle Bracket (Mounting Option, not required for single station)	3	0
Angled Enclosure with Hold Open Door (Mounting Option)	4	1
Vertical Enclosure with Hold Open Door (Mounting Option)	5	1
EFX Series Faucet	6	1
Basys Style ESD 500 Soap Dispenser Note: If ESD-500 Selected – Area under the sink must be clear for proper installation access and soap bottle change (no outlets, stops, etc).	7	1
Grid Strainer	8	1

Designer Series™ DSG-80000 and DSOF-80000 Sinks

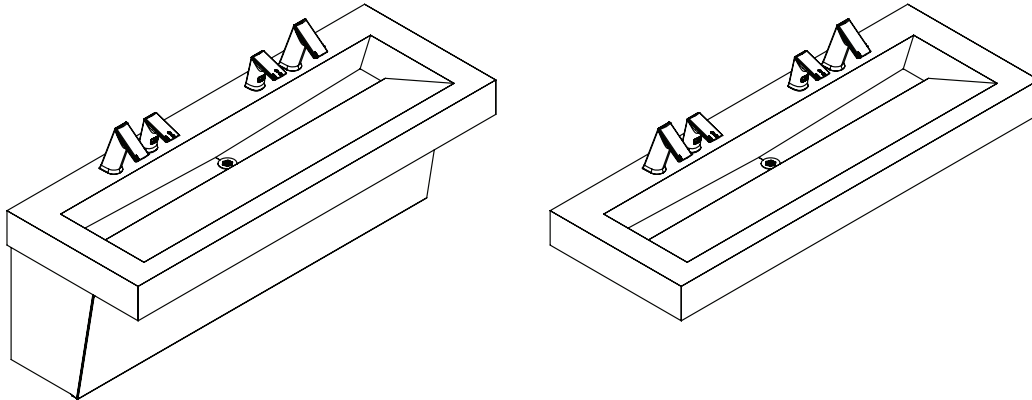

Sink Location

Determine the appropriate wall location for the Lavatory System. Consider that hot and cold water supply lines, a drain line, and an electrical source (receptacle for hardwired faucets and hand dryer) will be required. Compare the physical dimensions of the Lavatory System to the space available for the installation. If wall is not load bearing, a carrier may be required behind the wall. Refer to the appropriate Rough-in diagrams for Lavatory System dimensions. Prior to Lavatory System installation, electric wiring, water supply and drain must be installed.

DSG-82000, Two Station Components

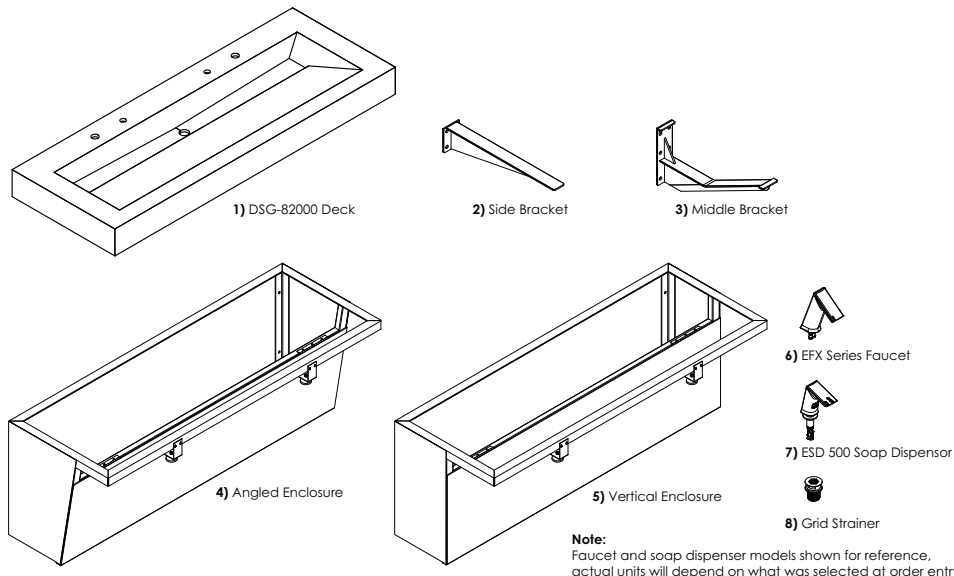

DSG-82000, Two Station Component List

Description	Item Number	Quantity
Designer Series Gradient, Two Station, Deck	1	1
Side Bracket <i>(Mounting Option)</i>	2	2
Middle Bracket <i>(Mounting Option, not required for single station)</i>	3	2
Angled Enclosure with Hold Open Door <i>(Mounting Option)</i>	4	1
Vertical Enclosure with Hold Open Door <i>(Mounting Option)</i>	5	1
EFX Series Faucet	6	2
Basys Style ESD 500 Soap Dispenser Note: If ESD-500 Selected – Area under the sink must be clear for proper installation access and soap bottle change (no outlets, stops, etc).	7	2
Grid Strainer	8	1

Designer Series™ DSG-80000 and DSOF-80000 Sinks

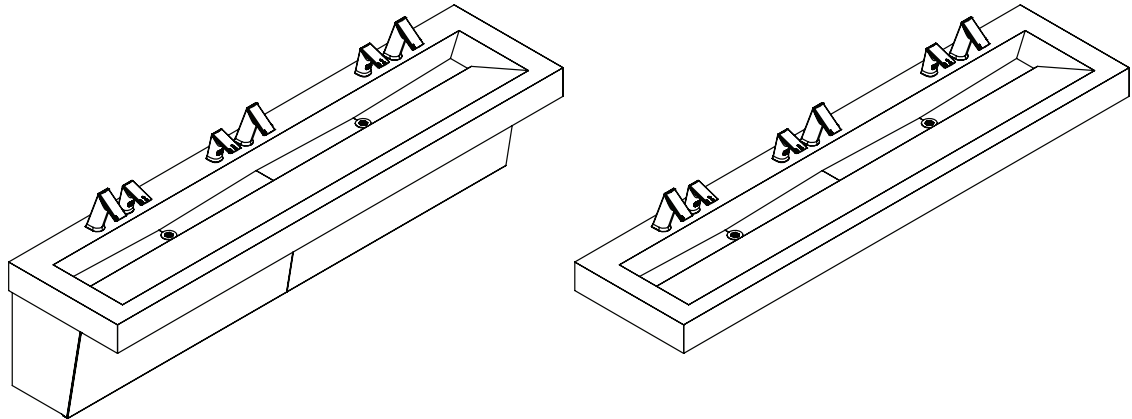

Sink Location

Determine the appropriate wall location for the Lavatory System. Consider that hot and cold water supply lines, a drain line, and an electrical source (receptacle for hardwired faucets and hand dryer) will be required. Compare the physical dimensions of the Lavatory System to the space available for the installation. If wall is not load bearing, a carrier may be required behind the wall. Refer to the appropriate Rough-in diagrams for Lavatory System dimensions. Prior to Lavatory System installation, electric wiring, water supply and drain must be installed.

DSG-83000, Three Station Components

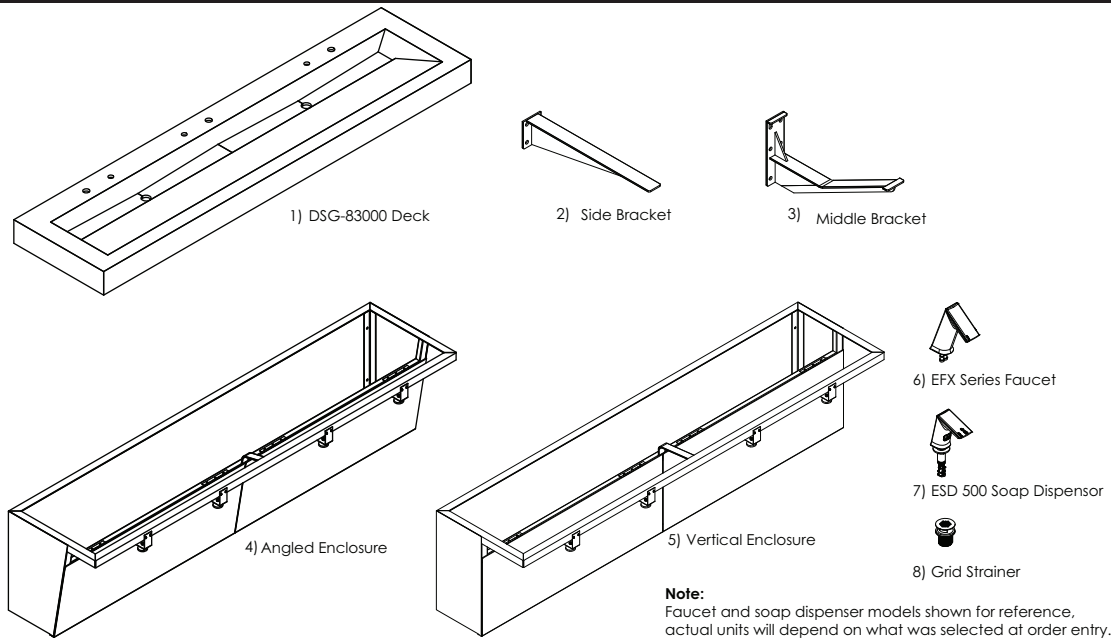

DSG-83000, Three Station Component List

Description	Item Number	Quantity
Designer Series Gradient, Three Station, Deck	1	1
Side Bracket (<i>Mounting Option</i>)	2	2
Middle Bracket (<i>Mounting Option, not required for single station</i>)	3	4
Angled Enclosure with Hold Open Door (<i>Mounting Option</i>)	4	1
Vertical Enclosure with Hold Open Door (<i>Mounting Option</i>)	5	1
EFX Series Faucet	6	3
Basys Style ESD 500 Soap Dispenser Note: If ESD-500 Selected – Area under the sink must be clear for proper installation access and soap bottle change (no outlets, stops, etc).	7	3
Grid Strainer	8	2

Designer Series™ DSG-80000 and DSOF-80000 Sinks

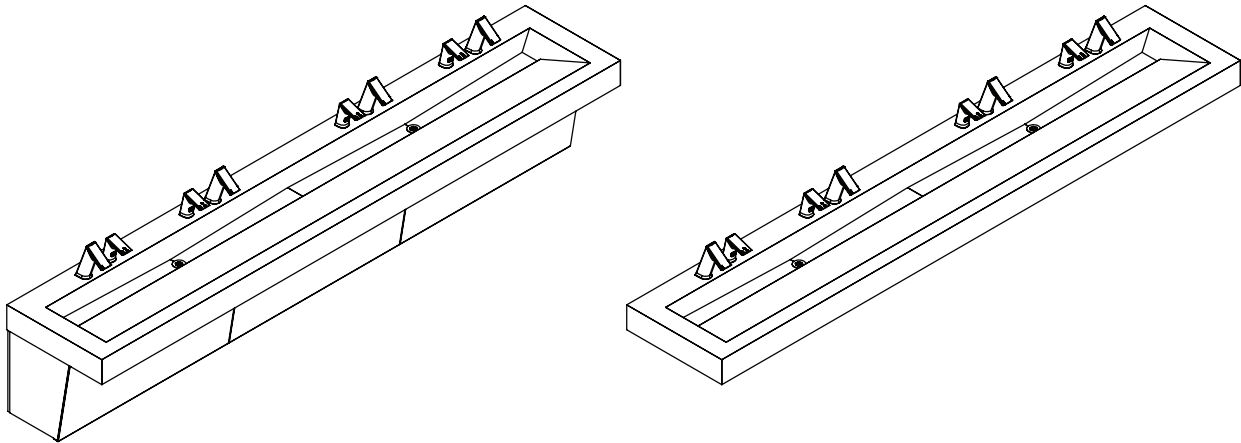

Sink Location

Determine the appropriate wall location for the Lavatory System. Consider that hot and cold water supply lines, a drain line, and an electrical source (receptacle for hardwired faucets and hand dryer) will be required. Compare the physical dimensions of the Lavatory System to the space available for the installation. If wall is not load bearing, a carrier may be required behind the wall. Refer to the appropriate Rough-in diagrams for Lavatory System dimensions. Prior to Lavatory System installation, electric wiring, water supply and drain must be installed.

DSG-84000, Four Station Components

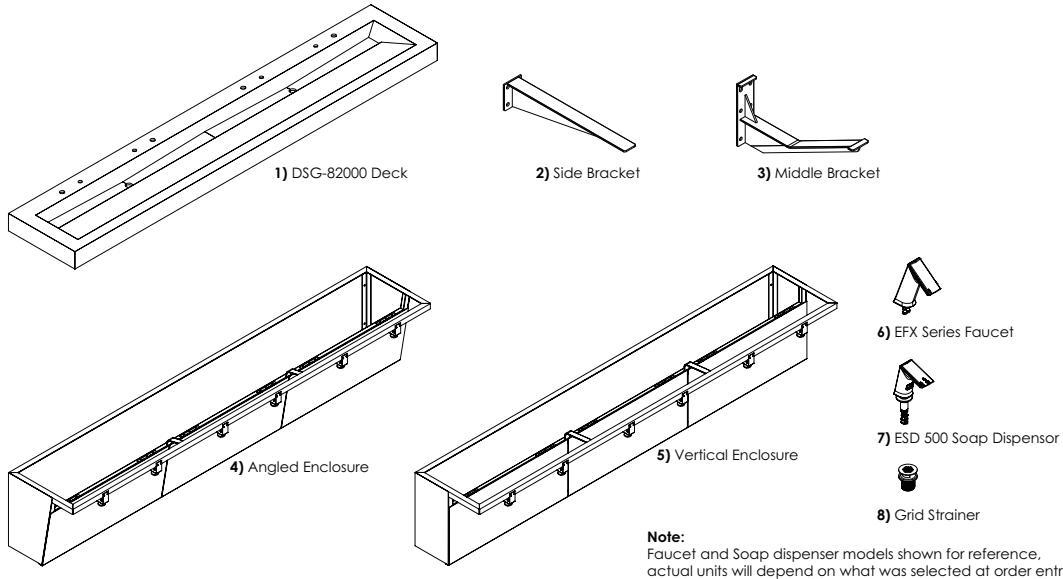

DSG-84000, Four Station Component List

Description	Item Number	Quantity
Designer Series Gradient, Four Station, Deck	1	1
Side Bracket <i>(Mounting Option)</i>	2	2
Middle Bracket <i>(Mounting Option, not required for single station)</i>	3	6
Angled Enclosure with Hold Open Door <i>(Mounting Option)</i>	4	1
Vertical Enclosure with Hold Open Door <i>(Mounting Option)</i>	5	1
EFX Series Faucet	6	4
Basys Style ESD 500 Soap Dispenser Note: If ESD-500 Selected – Area under the sink must be clear for proper installation access and soap bottle change (no outlets, stops, etc).	7	4
Grid Strainer	8	2

Designer Series™ DSG-80000 and DSOF-80000 Sinks

TROUBLESHOOTING GUIDE

Refer to appropriate faucet pages in Maintenance Guide.

1. No water flows when sensor is activated

Ensure that main power supply is turned "ON." Check receptacle, transformer, batteries (battery powered models), solenoid, leads and connections.

INDICATOR: If Sensor LED does not blink:

- A. Control module circuit board is faulty; replace.
- B. Sensor is faulty; replace sensor module.

INDICATOR: If Sensor LED blinks when user is sensed:

- A. Supply Stop(s) may be closed; open Supply Stop(s).
- B. Debris may be in Solenoid filter; remove, clean and reinstall.

2. Very low flow or slow dribble

- A. Supply Stop(s) may be closed; open Supply Stop(s).
- B. Debris is in solenoid, won't close properly; remove operator and clean. Reassemble in the same manner.
- C. Debris may be in Solenoid filter; remove, clean and reinstall.
- D. Debris is in aerator; remove, clean and reinstall.

3. Continues to run (even after power to faucet has been disconnected)

- A. Solenoid valve is installed backwards; install correctly.
- B. Debris is in solenoid, won't close properly; remove operator and clean. Reassemble in the same manner.

Solenoid Screen Filter Cleaning

- A. Before cleaning the Screen Filter, turn off the water supply at supply stop(s).
- B. Activate the Faucet to relieve any pressure in the system.
- C. Unscrew the Filter Cap and remove it from the Solenoid Valve Housing.
- D. Carefully remove the Screen Filter from the Solenoid Valve Housing.
- E. Clean the Screen Filter using fresh tap water only. If necessary, use a small brush to clean.
Use caution while cleaning to prevent damage to Screen Filter.
- F. Examine the Copper Washer or O-ring for wear or damage; replace if necessary. Carefully replace the Screen Filter into Filter Cap. Screw the Filter Cap with Copper Washer or O-ring into Solenoid Valve Housing and tighten securely to prevent leaks.
- G. Turn on the water supply at the supply stop(s). Activate the Faucet to purge any air from the system lines. Check for leaks and repair as necessary.

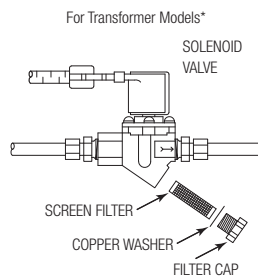

Material Description: Corian Material is made from a blend of acrylic modified bio-based polyester resin. Engineered Stone is 90% natural quartz and polyester resin and is resistant to chemicals, stains, burns and impact. Surface damage can be easily repaired with everyday cleansers or fine grit abrasives.

Routine Cleaning: For regular cleaning, use standard commercial or household products such as Simple Green®, Creamy Cleanser brand, Formula 409® or Windex®.

Stubborn Stains: Remove tough stains, with non abrasive cleaners and pads such as a white Scotch Brite® pad and Lysol®. Special Situations for Corian and Engineered Stone

Hard Water Deposits: Remove hard water deposits with a mild solution of vinegar and water. Always rinse the unit thoroughly after cleaning.

Repair Kits: Corian repair kits are available. Contact your Sloan Stone Sink Systems representative or distributor for part numbers and pricing. Repair kits are made to order and have a shelf life of 30 days. Engineered Stone shades of color can vary from product to product.

BRAND NAMES

Use of brand names is intended only to indicate a type of cleaner. This does not constitute an endorsement, nor does the omission of any brand name cleaner imply inadequacy. Many products named are regional in distribution, and can be found in local supermarkets, department and hardware stores, or through your cleaning service. It is emphasized that all products should be used in strict accordance with package instructions.

**When assistance is required, please contact
Sloan Technical Support at: 1-888-SLOAN-14 (1-888-756-2614).**

Stainless Steel EHS-1000 Sink

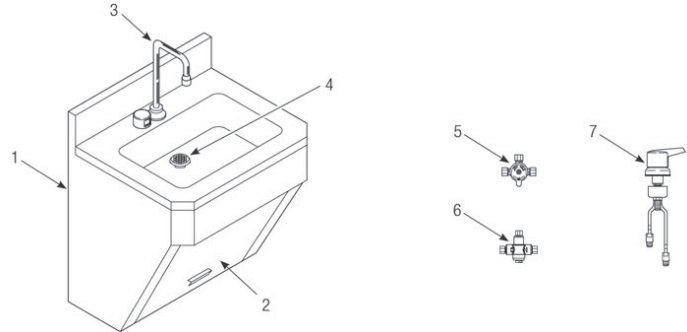

Item No.	Part No.	Description
1.	—	Sink Cabinet
2.	—	Access Panel
3.	—	Lavatory or Gooseneck Faucet Assembly
4.	—	Grid Strainer Assembly
—	—	Drain/P-Trap Assembly (not shown)
—	—	Deluxe Triple Station Scrub Sink (not shown)

Item No.	Part No.	Description
5.	MIX-60-A	Below Deck Mechanical Mixing Valve (Optional/BDM Variation)
6.	MIX-135-A	Below Deck Thermostatic Mixing Valve (Optional/BDT Variation)
7.	MIX-110-AA	Optimix® Deck Mounted Thermostatic Mixing Valve (Optional/ADM)
—	ETF-1009-A	Solenoid Valve Repair Kit (not shown)

Stainless Steel EHS-1000 Sink

TROUBLESHOOTING GUIDE

For Models:

EHS-1080 Hand Washing Sink with ETF-80 Faucet
EHS-1600 Hand Washing Sink with ETF-600 Faucet
EHS-1660 Hand Washing Sink with ETF-660 Faucet

Note: Remove Cover from Control Module to check diagnostic lights.

1. PROBLEM: No water is delivered when Faucet is activated.

INDICATOR: If no LED lights illuminate:

CAUSE: No electricity is being supplied to Faucet.

SOLUTION: Ensure that the main power is turned "ON." Check all Transformer, Sensor, Solenoid and Cable Connections. Make sure that Transformer is supplying 24 VAC (Volts AC). If no voltage is detected, replace Transformer.

CAUSE: There is an electrical system malfunction.

SOLUTION: Reset electrical system. Unplug Sensor Connection. Disconnect power to circuit for ten (10) seconds. Reconnect.

INDICATOR: If the GREEN LED does NOT illuminate when power is reconnected:

CAUSE: There is an electrical system malfunction.

SOLUTION: Reset electrical system. Unplug Sensor Connection. Disconnect power to circuit for ten (10) seconds. Reconnect.

CAUSE: The Control Module circuit is "dead."

SOLUTION: Replace ETF-450-A Control Module.

INDICATOR: If GREEN LED illuminates AND changes to RED when hands are in the Sensor's detection zone AND the RED Solenoid LED illuminates:

CAUSE: Water supply stop(s) may be partially closed.

SOLUTION: Open supply stop(s) completely.

CAUSE: Debris is clogging Solenoid Filter.

SOLUTION: Shut off water supply. Remove, clean and reinstall Solenoid Filter.

INDICATOR: If GREEN LED illuminates AND changes to RED when hands are placed in the Sensor's detection zone AND the RED Solenoid LED flickers with a vibrating/clicking noise heard inside the module:

CAUSE: There is a direct short in the Solenoid or Solenoid Cable.

SOLUTION: Replace with ETF-370-A Solenoid.

INDICATOR: If GREEN/RED LED illuminates AND changes to RED when hands are NOT located in the Sensor's detection zone BUT the RED Solenoid LED (in upper left corner of circuit) does NOT illuminate:

CAUSE: Sensor range is set too long and is detecting the sink.

SOLUTION: Reduce Sensor detection range.

INDICATOR: If GREEN LED illuminates BUT does NOT change to RED when hands are placed in the Sensor's detection zone:

CAUSE: Sensor range is set too short.

SOLUTION: Increase Sensor detection range.

EHS-1700 Hand Washing Sink with ETF-700 Faucet
EHS-1770 Hand Washing Sink with ETF-770 Faucet

2. PROBLEM: Sensing Range is too short.

CAUSE: Extended Range Sensitivity is required.

SOLUTION: Dip Switch number 4 should be in the "DOWN" (Extended Range Sensitivity) position. Increase range by adjusting Range Potentiometer clockwise (yellow phillips screw in blue base).

CAUSE: Faucet has Surgical Bend Gooseneck Spout.

SOLUTION: For Long Range use (recommended for Surgical Bend Gooseneck Spout Faucet models), remove Range Jumper from upper right hand corner of Circuit Board. Adjust Range Potentiometer.

3. PROBLEM: Faucet activates by itself (false triggers).

CAUSE: Sensor range is set too long.

SOLUTION: Decrease range by adjusting Range Potentiometer counterclockwise. If necessary, flip Dip Switch number 4 to the "UP" (Reduced Range Sensitivity) position. Check surroundings for factors that contribute to Sensor range detection problems (bright lights, highly reflective surfaces, sunlight, etc.).

4. PROBLEM: Faucet delivers very low flow or just a dribble.

CAUSE: Water supply stop(s) may be partially closed.

SOLUTION: Open supply stop(s) completely.

CAUSE: Debris is clogging Solenoid Filter.

SOLUTION: Shut off water. Remove, clean, and reinstall Solenoid Filter.

CAUSE: Solenoid is worn or faulty.

SOLUTION: Rebuild with ETF-1009-A Solenoid Repair Kit or replace ETF-370-A Solenoid.

CAUSE: Debris is clogging Faucet Aerator or Spray Head.

SOLUTION: Shut off water. Remove Aerator or Spray Head (use Key if required). Clean and reinstall Aerator or Spray Head.

5. PROBLEM: Faucet does not stop delivering water or continues to drip after user is no longer detected (even after power to the Module has been disconnected).

CAUSE: Solenoid Valve is installed backward.

SOLUTION: Disconnect Solenoid. Reconnect Solenoid with water flow toward the Faucet (see arrow on Solenoid).

CAUSE: Debris is clogging Solenoid.

SOLUTION: Remove and clean Solenoid Operator. If necessary, rebuild with ETF-1009-A Repair Kit.

CAUSE: Seat in Solenoid Valve body is damaged or pitted.

SOLUTION: Replace with ETF-370-A Solenoid.

Stainless Steel EHS-1000 Sink

TROUBLESHOOTING GUIDE

For Model:

EHS-1750 Hand Washing Sink with EBF-750 Faucet

Note: Remove Cover from Control Module to check diagnostic lights.

1. PROBLEM: Sensor LED does not function (indicator light on sensor window in faucet spout does not flash during initial 10 minute set-up mode).

CAUSE: There is no visible indicator light. Normal operation.

SOLUTION: This is a normal operating feature of the faucet.

2. PROBLEM: Faucet does not deliver any water when Sensor is activated.

INDICATOR: Solenoid valve produces audible "CLICK."

CAUSE: Water supply stop(s) closed.

SOLUTION: Open supply stop(s) completely.

INDICATOR: Solenoid valve DOES NOT produce an audible "CLICK."

CAUSE: Solenoid Lead is not properly connected to the Control Module.

SOLUTION: Disconnect and reconnect Solenoid Lead to Control Module.

CAUSE: No battery or Transformer power is being supplied to Sensor.

SOLUTION: Ensure that the batteries are installed properly. Check that the orientation of each battery matches the positive (+) and negative (—) symbols shown at bottom of battery compartment. Reinsert Batteries into Control Module. Transformer (optional) is unplugged or wall receptacle has no power.

CAUSE: Sensor Cable is not properly connected to the Control Module.

SOLUTION: Disconnect and reconnect Sensor Cable to Control Module.

CAUSE: Sensor range is set at minimum distance.

SOLUTION: Increase Sensor range.

CAUSE: Control Module assembly is defective.

SOLUTION: Replace Control Module assembly.

3. PROBLEM: Faucet delivers only a slow flow or dribble when Sensor is activated.

CAUSE: Water supply stop(s) partially closed.

SOLUTION: Open supply stop(s) completely.

CAUSE: Solenoid Filter is clogged.

SOLUTION: Remove, clean and reinstall Filter.

CAUSE: Aerator or Spray Head is clogged.

SOLUTION: Remove, clean and reinstall Aerator or Spray Head.

4. PROBLEM: Faucet does not stop delivering water or continues to drip after user is no longer detected (automatic shut-off fails even when batteries are removed).

CAUSE: Solenoid Valve has been connected backwards.

SOLUTION: Disconnect Solenoid Valve compression fittings at both the inlet and outlet positions. The water should flow from inlet through the Solenoid Valve to the outlet according to the direction of the arrow shown on the side of the Solenoid Valve. Reconnect the compression fittings in the correct orientation.

CAUSE: Solenoid Valve is dirty.

SOLUTION: Backflush by reversing water flow (opposite to the direction shown by the arrow on the side of the Solenoid Valve) through the Solenoid Valve. Reconnect the compression fittings in the correct orientation. Activate faucet.

5. PROBLEM: The water temperature is too hot or too cold on a faucet connected to hot and cold supply lines with Bak-Chek® Tee.

CAUSE: Supply stops are not adjusted properly.

SOLUTION: Adjust supply stops.

NOTE: For some systems, a Thermostatic Mixing Valve may be required.

6. PROBLEM: Red LED turns on in the control module (below deck).

CAUSE: One (or more) of the batteries is "dead."

SOLUTION: To ensure proper operation, insert four (4) new AA-size Alkaline batteries. Check that the orientation of each battery matches the positive (+) and negative (—) symbols shown on the bottom of the battery compartment. Reinsert Batteries into the Control Module.

NOTE: Upon start-up mode (1st ten minutes) the control module circuitry tests the batteries and the Red LED turns on if the battery voltage is low. No Red LED light indicates normal battery voltage.

NOTE: If reset button is pressed (initiates start up mode/1st ten minutes), the battery voltage is checked. If voltage is too low, product is stopped from operating and Red LED will turn on. No Red LED light indicates normal battery voltage.

7. PROBLEM: Green LED initially turns on in the control module (below deck) during start up mode, then will not appear again.

CAUSE: For the 1st ten minutes of operation (batteries inserted or reset button pressed) the Green LED will turn on when there is a target present (hands in front of sensor). After ten minutes, the Green LED will no longer turn on.

SOLUTION: This is a normal operating feature of the faucet.

**Stainless ESS-2000
ESS-3000 Sinks**

ESS-2100 Single Station Scrub Sink

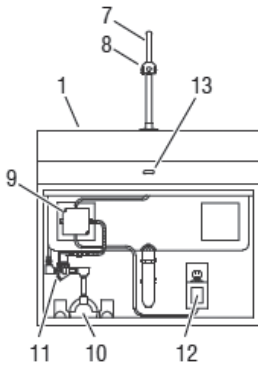

ESS-3100 Deluxe Single Station Scrub Sink

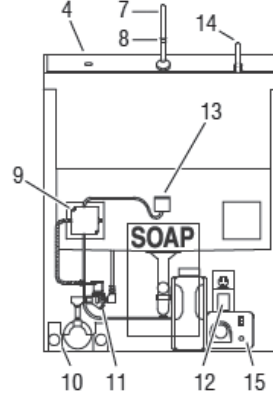

ESS-2200 Double Station Scrub Sink

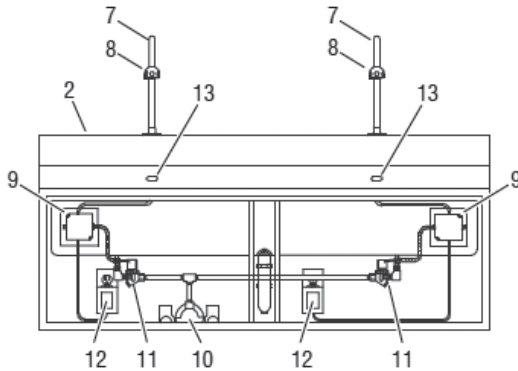

ESS-3200 Deluxe Double Station Scrub Sink

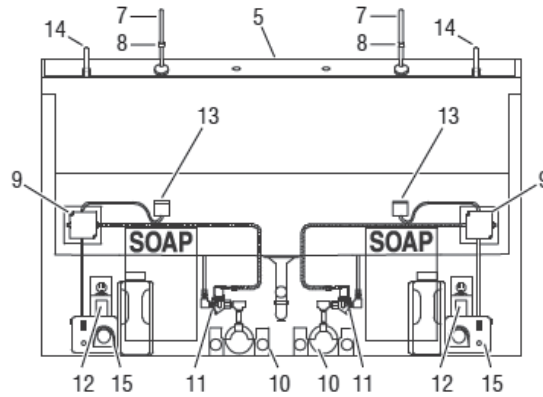

ESS-2300 Triple Station Scrub Sink

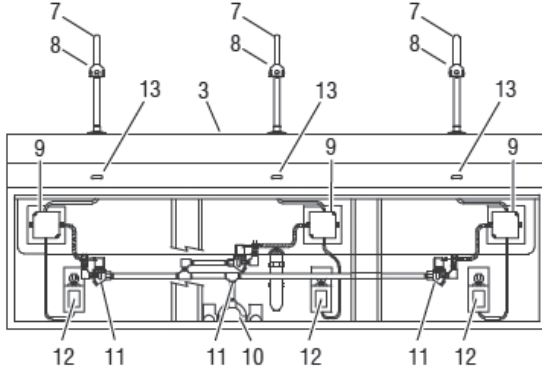

ESS-3300 Deluxe Triple Station Scrub Sink

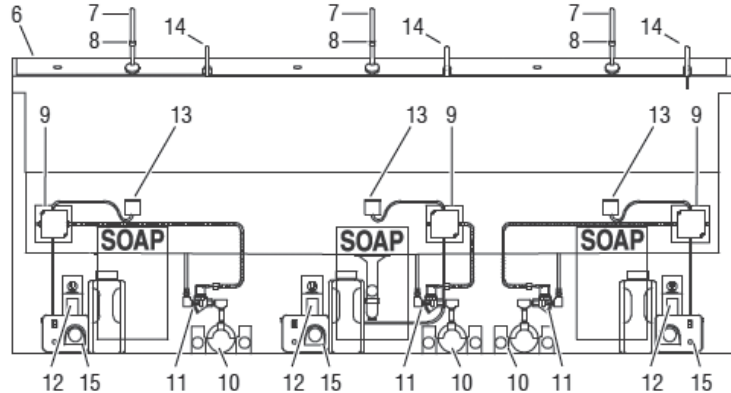

Item No.	Part No.	Description
1.	ESS-2100	Single Station Scrub Sink
2.	ESS-2200	Double Station Scrub Sink
3.	ESS-2300	Triple Station Scrub Sink
4.	ESS-3100	Deluxe Single Station Scrub Sink
5.	ESS-3200	Deluxe Double Station Scrub Sink
6.	ESS-3300	Deluxe Triple Station Scrub Sink
7.	AC-93-A	Sloan Optima® Gooseneck Faucet-Surgical Bend
8.	ETF-237	Laminar Flow Spray Head, 2.2 gpm (8.3 Lpm) Max.
	AC-55-A	Shower Spray Head, 2.2 gpm (8.3 Lpm) Max.
9.	ETF-492-A	Control Module

Item No.	Part No.	Description
10.	MIX-70-A	Below Deck Thermostatic Mixing Valve
	MIX-110-A	Above Deck Mechanical Mixing Valve
	MIX-139-A	Above Deck Thermostatic Mixing Valve
11.	ETF-370-A	Solenoid Valve
12.	ETF-233	Plug-in Transformer
13.	EL-1500-LL-S	Sensor
14.	—	Soap Dispenser Spout
15.	—	Soap Dispenser Spout Pump and Reservoir

Stainless ESS-2000 ESS-3000 Sinks

Troubleshooting the Faucet

No water flows when sensor is activated

Ensure that main power supply is turned "ON." Open control module and check diagnostic lights. Check receptacle, transformer, solenoid, leads and connections. If no lights are illuminated:

1. Control module circuit board is faulty; replace.

If green LED is illuminated and red LED illuminates when user is sensed:

1. Supply Stop(s) may be closed; open Supply Stop(s).
2. Debris may be in Solenoid Filter; remove, clean and reinstall.

If green LED is illuminated and red LED DOES NOT illuminate when user is sensed:

1. Sensor range is too long (picking up sink); reduce range.
2. Sensor is faulty; replace Sensor Module.

Very low flow or slow dribble

1. Supply Stop(s) may be closed; open Supply Stop(s).
2. Debris in Solenoid; disassemble Solenoid; clean and flush.
3. Debris may be in Solenoid Filter; remove, clean and reinstall.
4. Debris is in Aerator or Spray Head; remove, clean and reinstall.

False triggering (unit activates by itself)

1. Sensor range is too long; reduce range. Check surroundings for factors that can contribute to sensor detection problems; for example, bright lights, highly reflective surfaces, sunlight, etc.

Continues to run (even after power to faucet has been disconnected)

1. Solenoid valve is installed backwards.
2. Debris is in Solenoid, won't close properly; remove operator and clean. Reassemble Troubleshooting the Soap Dispenser

Soap does not dispense from the spout.

1. Soap reservoir is empty. Check the soap reservoir and fill if necessary.
2. Soap dispenser is not plugged in. Plug the soap dispenser power cord into the wall receptacle.
3. Power is not supplied to the wall receptacle. Check to make sure that power is being supplied to the wall receptacle.

How does one keep soap from dispensing while cleaning.

1. Unplug the soap dispenser power cord from the wall receptacle.

ESD-360 Series Top Fill Foam Soap Dispenser



ESD-360



ESD-113

ESD-124

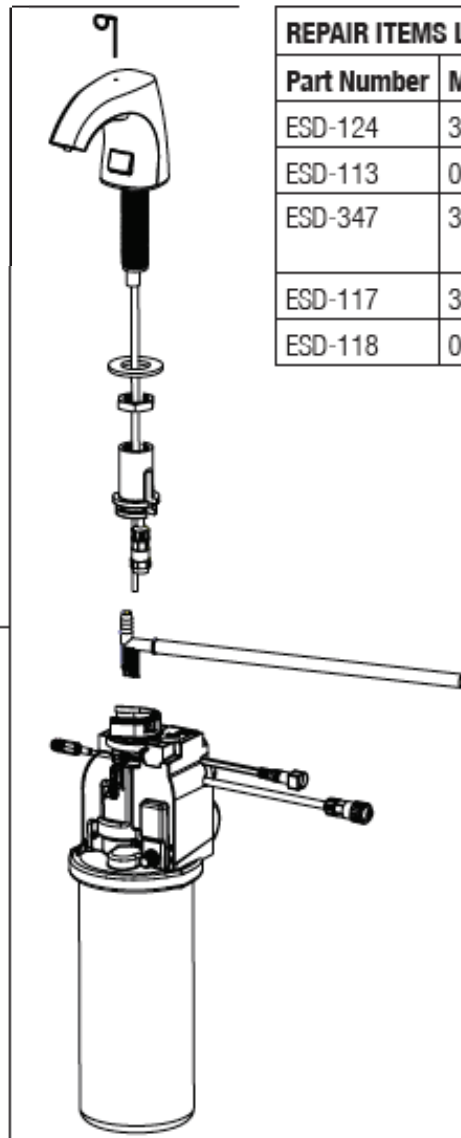

REPAIR ITEMS LIST		
Part Number	Material Number	Description
ESD-124	33461026	Spout with 2L Reservoir and Motor
ESD-113	03460019	Battery Pack
ESD-347	33461021	Soap Refills-Must purchase in quantities of 4
ESD-117	33461023	AC Plug
ESD-118	03460021	Hardwire Kit (Sold in Packs of 2)

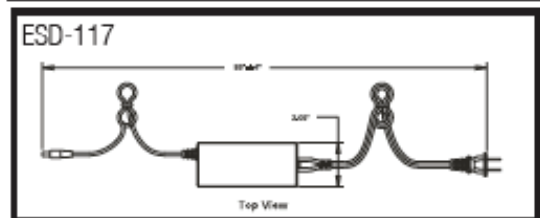
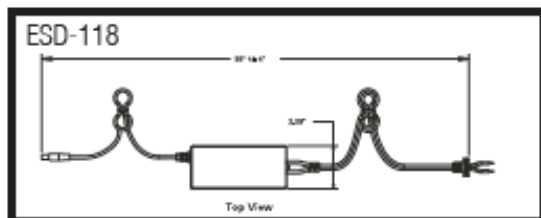
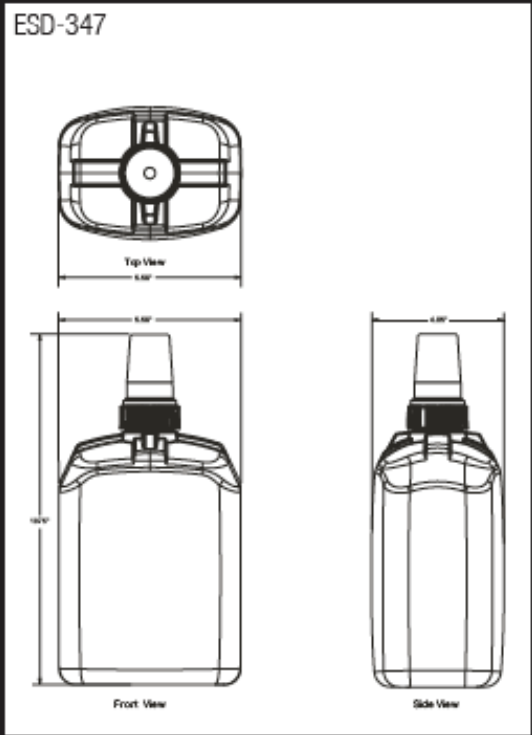

ESD-Series Foam Soap Dispensers

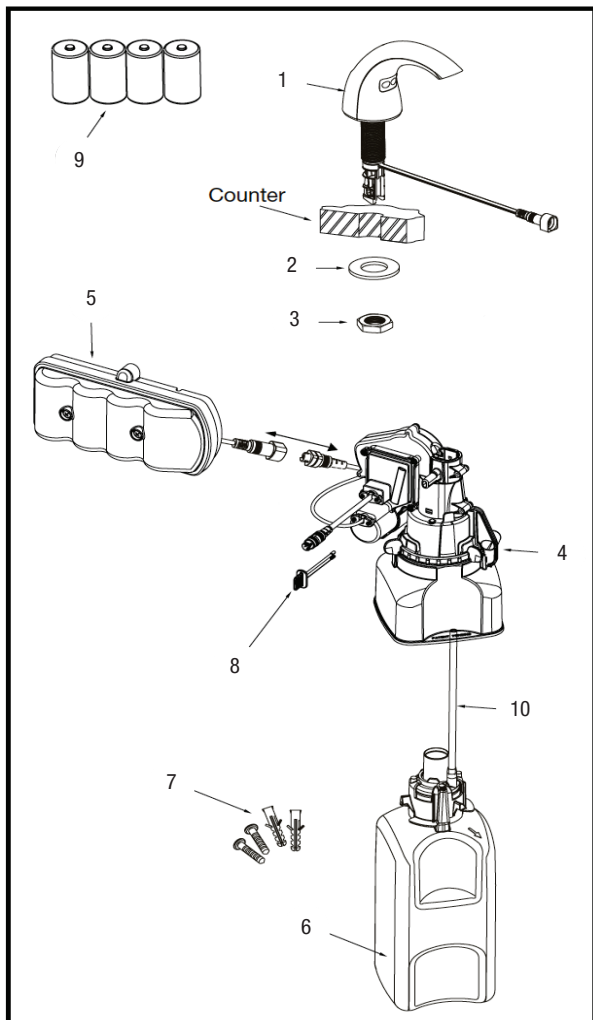

ITEM	DESCRIPTION	QTY.
1.	DISPENSER ASSEMBLY (SEE SPOUT LIST BELOW)	1
2.	FLAT WASHER	1
3.	NUT	1
4.	MOTOR ASSEMBLY (BOTTLE SUPPORT)	1
5.	BATTERY BOX (USES 4 "D" CELL BATTERIES)	1
6.	SOAP BOTTLE (2 BOTTLES SHIP WITH DISPENSER/ADDITIONAL SOLD SEPARATELY)	1 BOX (2 BOTTLES)
7.	SCREWS & ANCHORS FOR BATTERY BOX MOUNTING	1
8.	RETAINING CLIP	1
9.	"D" CELL BATTERIES (PROVIDED)	4
10.	SOAP BOTTLE TUBE	1
NOT SHOWN	ESD-324 6 VDC PLUG-IN ADAPTER (100-240 VAC) (SOLD SEPARATELY)	

REPAIR PARTS (IN KIT FORM- TAKEN FROM ITEM NUMBERS ABOVE)

REPAIR PARTS AVAILABLE TO ORDER	DESCRIPTION	MATERIAL NUMBER
ESD-218	*ALTERNATE MOUNTING FLANGE NUT	*0346002
ESD-320	SOAP DISPENSING MOTOR (INCLUDES BATTERY BOX #5)	0346081
ESD-321	GREEN CERTIFIED FOAM SOAP REFILLS 1500 ML (2 PER BOX)	3346044
ESD-324	6 VDC PLUG-IN ADAPTER (100-240 VAC)	0346090)
ESD-340-A	STRAW ASM FOR SOAP BOTTLE	0346102

REPLACEMENT SPOUTS ONLY (INCLUDES NUT & WASHER)

ITEM	DESCRIPTION
1.	ESD-410
1.	ESD-420
1.	ESD-1502A CP SPOUT ASSEMBLY-EAF100/150 STYLE
1.	ESD-2002A CP SPOUT ASSEMBLY-EAF200/250/275 STYLE
1.	ESD-2102A CP SPOUT ASSEMBLY-SF-2100/2150 STYLE
1.	ESD-502A CP SPOUT ASSEMBLY BASYS STYLE
1.	ESD-602A CP SPOUT ASSEMBLY ETF-600/650 STYLE (610/615)
1.	ESD702A CP SPOUT ASSEMBLY EAF-700/750 STYLE
1.	EAF802A CP SPOUT ASSEMBLY ETF80/EBF-85

ESD-200/250 and ESD-300/350 Liquid Soap Dispensers

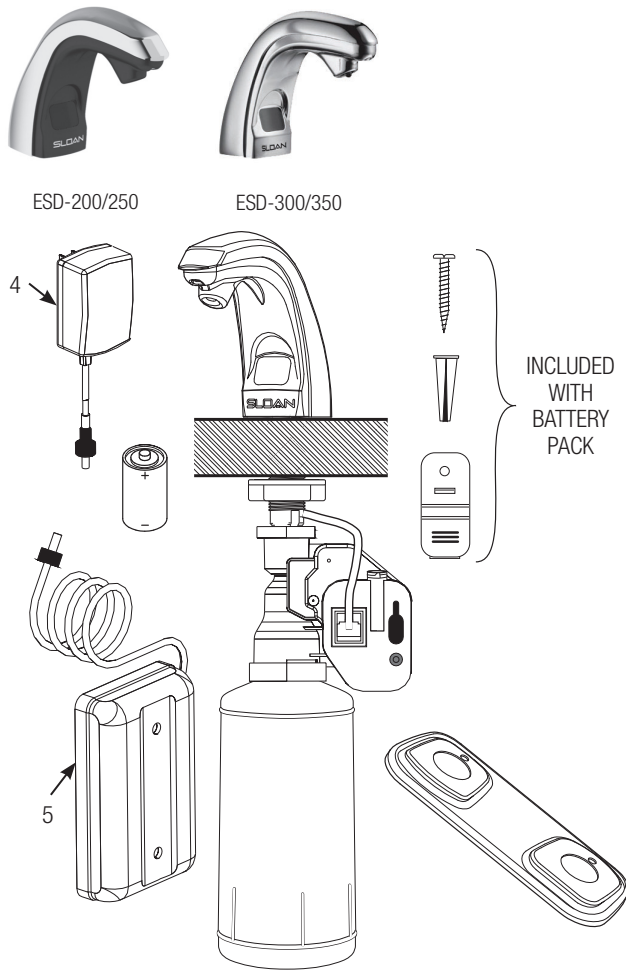

Item No.	Part No.	Description
1A.	ESD-216-A	Spout Assembly (Models ESD-200 & ESD-250)
1B.	ESD-235-A	Spout Assembly (Models ESD-300 & ESD-350)
2.	ESD-218	Mounting Hardware Kit (Includes items 2A and 2B)
2A.	ESD-222	Rubber Gasket
2B.	ESD-620	Flange Nut
3.	ESD-209-A	Motor Assembly
4.	ESD-227	Plug-in Transformer (Hardwire Models ESD-200 & ESD-300)
5.	ESD-210	Battery Pack — Includes 4 D-size batteries, Screws and Anchors for Battery Compartment and Wall Clips for Power Cord (Battery Models ESD-250 & ESD-350)
6.	ESD-217	Lotion Soap Refill Cartridge 800 ml (up to 1000 hand washes)
	ESD-232	Lotion Soap Refill Cartridge 1600 ml (up to 2000 hand washes)
	ESD-231	Anti-bacterial Soap Refill Cartridge 800 ml (up to 1000 hand washes)
	ESD-233	Anti-bacterial Refill Cartridge 1600 ml (up to 2000 hand washes)
7.	ESD-223	D-size Alkaline Batteries (4 required) (Models ESD-250 & ESD-350)
8.	ETF-299-A	Trim Plate for ESD-20080, ESD-25085, ESD-30880 & ESD-35187 Combination Soap Dispenser and Faucet

When the Soap Bottle is empty, a new Bottle must be used. The Bottle furnished with the unit is not designed to be refilled. Altering the Bottle and refilling it with soap will void the warranty of the product.

- ESD-233 — 1600 ml. bottle of Anti-bacterial Soap
Can also be replaced with TC® OneShot® Soap Bottles listed in chart.

Refills are available through your local plumbing or janitorial supply distributor.

Soap Refill Cartridges Available:

- ESD-217 — 800 ml. bottle of Lotion Soap
- ESD-232 — 1600 ml. bottle of Lotion Soap
- ESD-231 — 800 ml. bottle of Anti-bacterial Soap

I. Red LED light is flashing.

- Refill bottle is low. Check the fill level and change as needed.
- Reset button was not pressed after the refill was installed. Press and release reset button.
- If reset button is held down more than one second, the red light will stay on. To turn the red light off, press the reset button quickly and the red light will go off.

2. Yellow LED light is flashing (Models ESD-250 & ESD-350 only).

- Batteries are low. Replace with four (4) new D-size alkaline batteries.

3. Preventing soap from dispensing while cleaning.

- Place your finger over the upper right hand or left hand corner of the sensor lens.

4. The dispenser does not activate properly when hand is placed under spout.

- In rest rooms with fluorescent lighting, lighting that may be dying out or not burning at full intensity will cause interference with soap dispenser. Replace fluorescent tube(s) and soap dispenser will then function normally. Cool, white tubes are recommended.

5. Soap does not dispense when user “waves” their hands under the spout.

- Hands must be held “steady” under the spout for the dispenser to work.

6. Dispenser rotates due to users moving the spout.

- Tighten the existing flange nut on the shaft of the spout under the counter.
- If this problem continues, you can order a second “flange nut” (ESD-620) from Sloan Valve.

7. Soap does not dispense.

- Check that your power source is plugged in correctly.
- Make sure that batteries have been installed properly (Models ESD-250 & ESD-350 only).
- Make sure the pump is open on the refill bottle (see Step 5).

8. Tube pulls out of the refill bottle.

- The tubes have been “stitched” to prevent their removal, however please ensure that your housekeeping staff does not pick the bottle up or carry it by the tube.

SJS-1650 Soap Dispenser DISCONTINUED

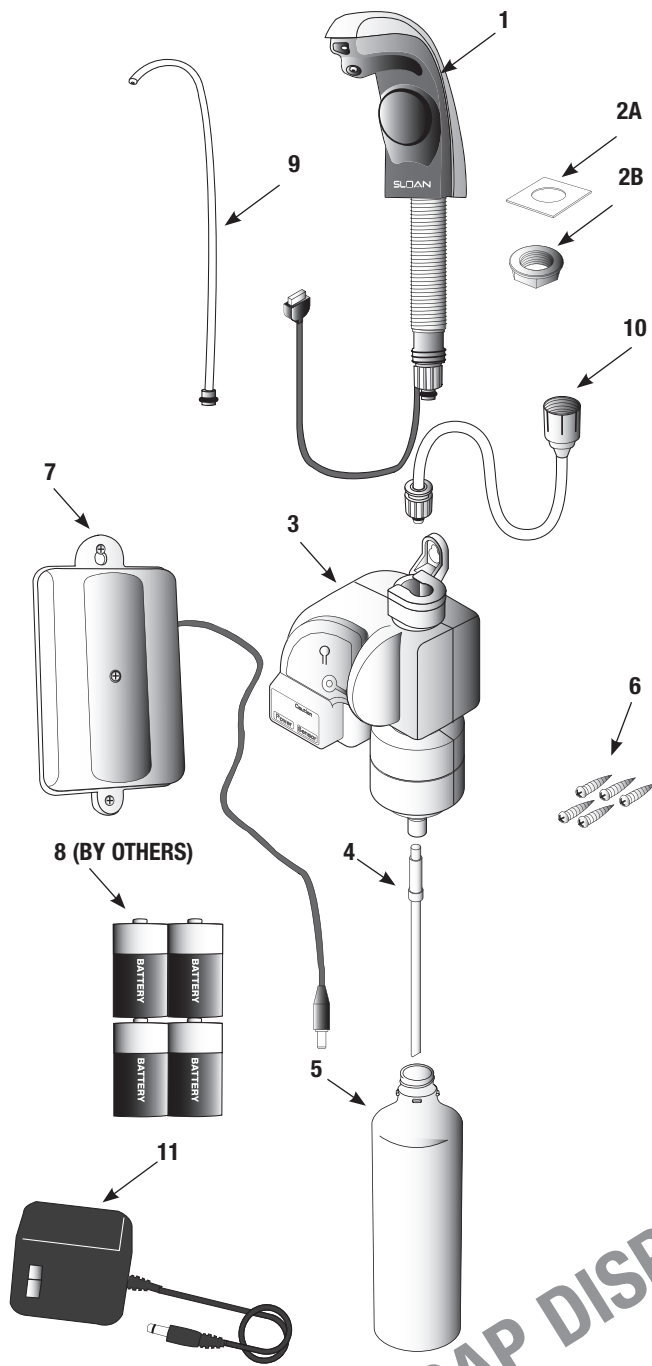

Item No.	Part No.	Description
1.	SJS-1-A	Spout Assembly
2A.	—	Rubber Gasket
2B.	—	Flange Nut
3.	SJS-5	Motor Assembly
4.	SJS-8	Pick-up Tube
5.	SJS-1651	Soap Bottle (sold separately)
6.	—	Mounting Screws (5)
7.	SJS-4	Battery Compartment
8.	—	D-size Alkaline Batteries (4) (supplied by others)
9.	SJS-2	Repair Kit Tube Assembly Soap Path
10.	SJS-3	Repair Kit Tube Assembly Extension
11.	SJS-7	Optional AC Adapter (sold separately)

CARE AND CLEANING OF CHROME AND SPECIAL FINISHES

DO NOT use abrasive or chemical cleaners (including chlorine bleach) to clean Soap Dispenser that may dull the luster and attack the chrome or special decorative finishes. Use ONLY mild soap and water, then wipe dry with clean cloth or towel.

While cleaning the bathroom tile, protect the Flushometer from any splattering of cleaner. Acids and cleaning fluids will discolor or remove chrome plating.

TROUBLESHOOTING GUIDE

1. Yellow LED light is flashing.

- A. Soap level is low. Check level and change as needed.
- B. Reset button was not pressed after the refill was installed. Press and release reset button.

2. Red LED light is flashing (battery power only).

- A. Batteries are low. Replace with four (4) new D-size alkaline batteries.

3. Soap does not dispense.

- A. Check that power source is plugged in correctly.
- B. Make sure batteries have been properly installed in the battery compartment.
- C. Check soap path for clogging. Remove and replace as needed.

4. Soap does not dispense when user "waves" their hands under the spout.

- A. Hands must be held steady under the spout for soap to be dispensed.

5. Dispenser rotates due to users moving the spout.

- A. Tighten the existing flange nut on the shank of the spout under the counter.
- B. Add a second flange nut from Sloan JanSan to act as a jam nut in conjunction with the nut already installed.

DISCONTINUED SOAP DISPENSER

SJS-1750 Foam Soap Dispenser DISCONTINUED



PARTS LIST—SENSOR-ACTIVATED, DECK-MOUNT FOAM SOAP DISPENSER

Item No.	Code No.	Part No.	Description
—	5700751	SJS-1751	Sensor Deck-Mount Foam Soap
—	5700752	SJS-1751-1	Sensor Deck-Mount Foam Soap with Moisturizers
—	5700754	SJS-1751-3	Sensor Deck-Mount Foam Soap Green Seal (Fragrance Free)
1.	7000027	SJS-55-A	Soap Dispenser Nozzle
—	—	—	Mesh Insert & O-ring

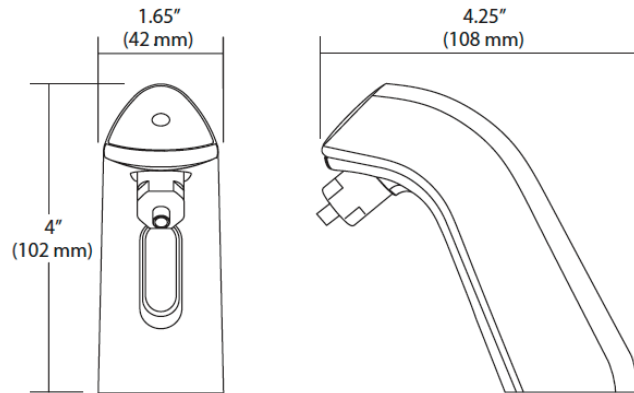
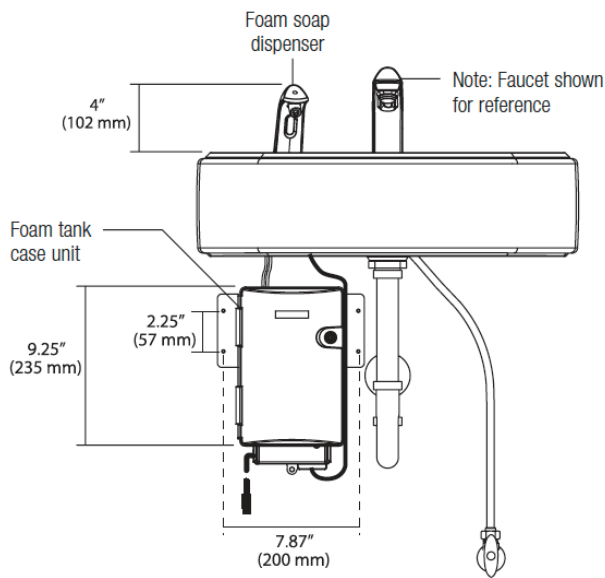

DISCONTINUED SOAP DISPENSER

SJS-1750 Foam Soap Dispenser
DISCONTINUED

TROUBLESHOOTING GUIDE

1. Unit DOES NOT operate.

- A. Check operation switch is on.
- B. Check power plug is securely inserted into the outlet.

2. Soap DOES NOT dispense.

- A. Soap bottle needs replacing.
- B. Check soap dispensing nozzle for clog.
- C. Check hand sensor.

3. Liquid soap is not in foam state.

- A. Check mesh is mounted in the foam-dispensing nozzle.

CLEANING THE HAND SENSOR

Clean the hand sensor periodically (about once a month) according to the following procedure:

- Press the operation switch to OFF (the operation light goes off).
- Gently wipe the hand sensor area with a cloth moistened with warm water.
- Press the operation switch to ON (the operation light goes on).
- Make sure that the nozzle properly dispenses foam soap.

NOTE: DO NOT leave water drops on the hand sensor area. Remaining water drops may cause malfunction.

CLEANING FOAM SOAP DISPENSER

If the tip of the soap nozzle is clogged, the dispensing capability may fail or function partially. Clean the nozzle according to the following procedure:

- Press the operation switch to OFF (the operation light goes off).
- Remove the foam soap dispensing nozzle and then the internal mesh. Wash it with lukewarm water.
- Turn ON the operation switch (the operation light goes on). Check the foam soap spraying state.
- Repeat as needed.

When assistance is required, please contact

Sloan Technical Support at: 1-888-SLOAN-14 (1-888-756-2614).

DISCONTINUED SOAP DISPENSER

EHD-510

EHD-420

EHD-410

BASYS® Style Rush Street® Style Clark Street® Style

HAND DRYER SPOUT PARTS LIST

Item No.	Code No.	Part No.	Description
1	0366050	EHD-511-A	BASYS Style Dryer Spout Repair Kit (Chrome)*
2	0366016	EHD-516-A	BASYS Style Dryer Crown Kit (Chrome)*
3	33660023	EHD-421	Rush Street Style Dryer Spout Repair Kit (Chrome)*
4	33660037	EHD-422	Rush Street Sensor Repair Kit
5	33660028	EHD-411	Clark Street Style Dryer Spout Repair Kit (Chrome)*
6	33660038	EHD-412	Clark Street Sensor Repair Kit
7	0366015	EHD-515-A	BASYS Holding Nut Assembly Repair Kit - Single Thread
	33660036	EHD-415	Rush and Clark Street Holding Nut Assembly Repair Kit - Double Thread
8	0366008	EHD-512-A	Hose and Muffler Repair Kit
9	0366009	EHD-513-A	Motor Assembly 110/120V with HEPA Filter (Plug type B)
	03660029	EHD-517-A	Motor Assembly 220V with HEPA Filter (International Only, Plug type M)
10	0366014	EHD-514-A	HEPA Filter Repair Kit (Filter with screen)

* Consult factory for alternate finish options. Replacement Dryer Spouts include respective Holding Nut (Item No. 3).

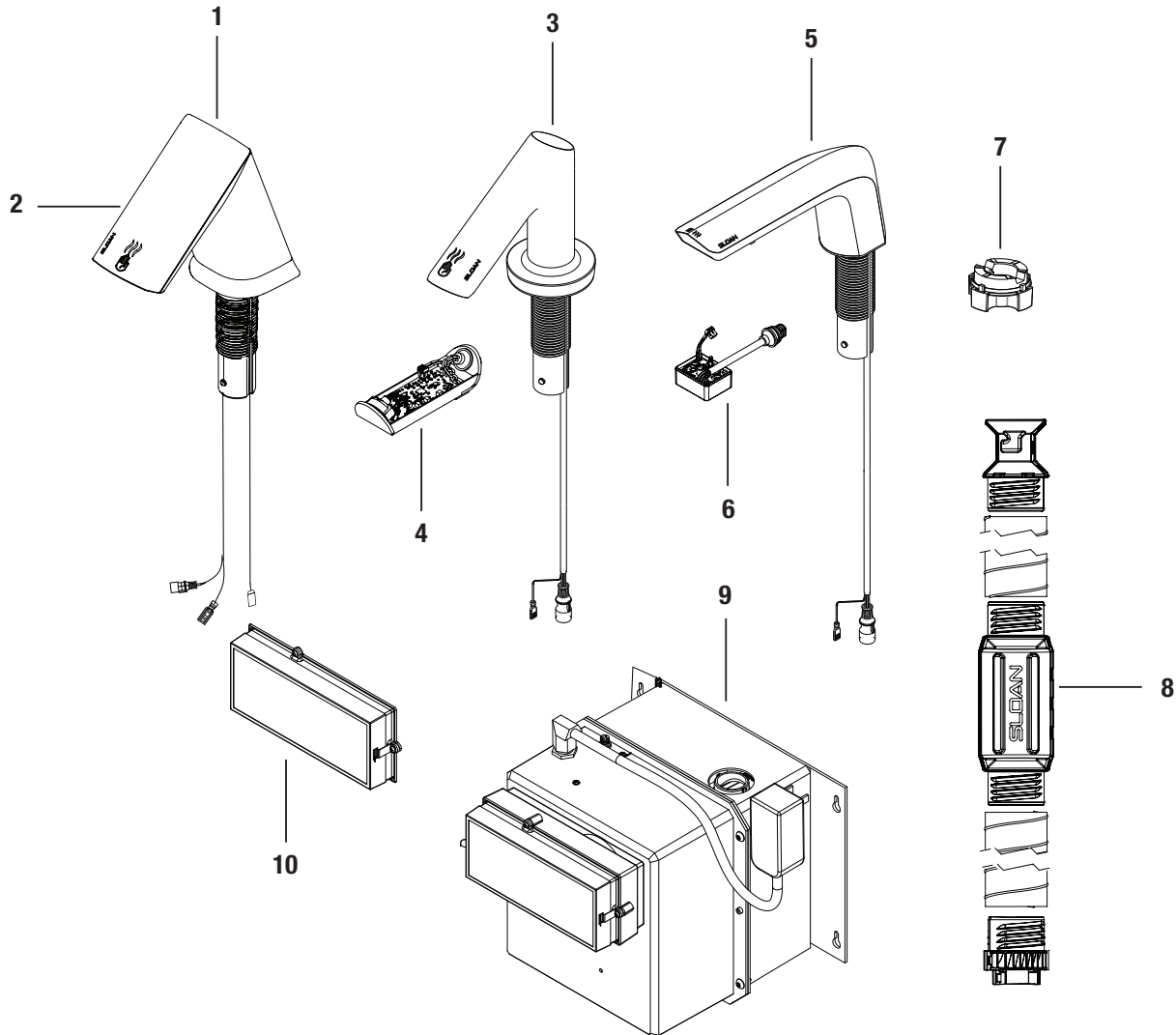

EHD-501 Hand Dryer

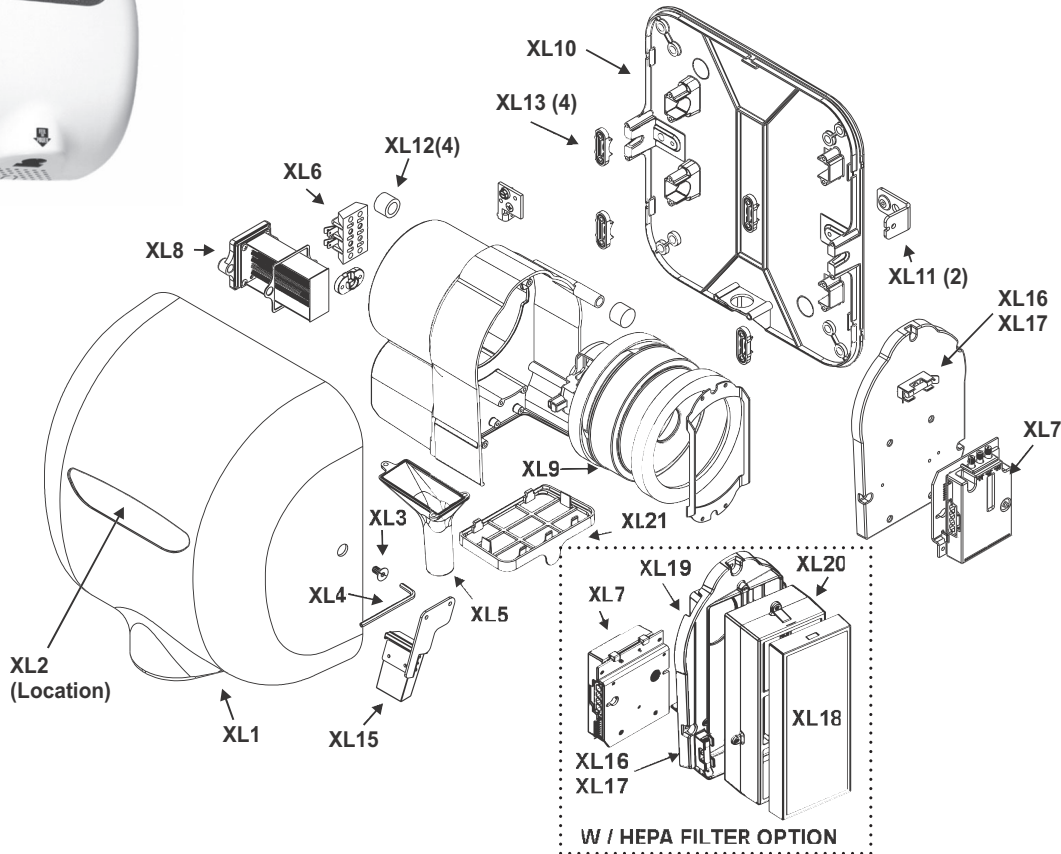

PARTS LIST—SENSOR-ACTIVATED, DECK-MOUNT FOAM SOAP DISPENSER

Ref. No.	Description
XL1.	Cover (includes Nameplate)
XL2.	Nameplate
XL3.	Tamper-proof Bolt
XL4.	Tamper-proof Wrench
XL5.	Air Outlet (includes gasket)
XL6.	Terminal Block (includes screws)
XL7.	Control Assembly & Sensor
XL8.	Heating Element Assembly*
XL9.	Motor
XL10.	Base Plate Assembly
XL11.	Cover Mounting Brackets
XL12.	Housing Grommet
XL13.	Housing Retainer
XL15.	Optics Assembly (Sensor)
XL16.	Fuseholder (if so equipped)
XL17.	Fuse (if so equipped)
XL18.	HEPA Pre-Filter**
XL19.	HEPA Filter Adapter**
XL20.	HEPA Filter**
XL21.	Pre-Filter

*does not apply to XLERATOReco models

**Only applies to HEPA models

Act-O-Matic® Showerhead



AC-11-1.8 4020132

Self-cleaning chrome plated showerhead with thumb screw volume control and universal ball joint. Pressure compensating 1.8gpm/6.8 Lpm maximum flow control. All brass construction. 1/2" I.P.S. inlet.

AC-11-2.0 4020130

Self-cleaning chrome plated showerhead with thumb screw volume control and universal ball joint. Pressure compensating 2.0 gpm/7.5 Lpm maximum flow control. All brass construction. 1/2" I.P.S. inlet.



AC-51 1.8 4020131

Self-cleaning chrome plated showerhead without (less) thumb screw volume control and universal ball joint. Pressure compensating 1.8 gpm/6.8 Lpm maximum flow control. All brass construction. 1/2" I.P.S. inlet.

AC-51 2.5 4021000

Self-cleaning chrome plated showerhead without (less) thumb screw volume control and universal ball joint. Pressure compensating 2.5 gpm/9.4 Lpm maximum flow control. All brass construction. 1/2" I.P.S. inlet.



AC-11 4020100

Self-cleaning chrome plated showerhead with thumb screw volume control and universal ball joint. Pressure compensating 2.5 gpm/9.4 Lpm maximum flow control. All brass construction. 1/2" I.P.S. inlet.

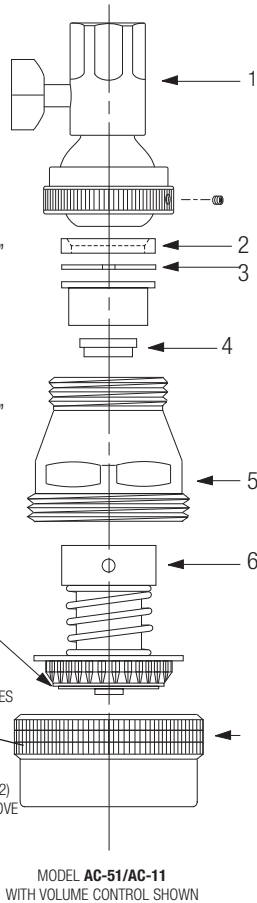

LABELS:
 BLUE COLOR 1.8
 GREEN COLOR 2.0
 BLACK COLOR 2.5
 BLUE COLOR 3.0
 OR ABOVE

GROOVE INDICATES SH-2-N.
 (NO GROOVE INDICATES OBSOLETE SH-2) 3.0 GPM OR ABOVE

PARTS FOR ACT-O-MATIC® SHOWERHEAD AC-11/AC-51 2.5 & 2.0, 1.8

Item No.	Code No.	Part No.	Description
1.	3328026	SH-1007-A	Ball Joint Coupling with Volume Control†
	0328059	AC-18-AV	Ball Joint Coupling less Volume Control
	0328213	AC-313-A	1.8 Gallon Flow Control
2.	0328205	AC-313-A	2.0 Gallon Flow Control Assembly*
	5328010	SH-1000-A	SH-3 Gasket – 24 per package
3.	0328010PK	SH-3	Single Gasket
	—	—	Spacer*
4.	0328209	C2A	Piston Assembly for Showerhead
	0328001	SH-1	Body†
6.	4328470	SH-1003-A	Piston Assembly† – DISCONTINUED
	—	AC-2-A-1.8	1.8 Piston Assembly – Shower Head
	—	AC-2-A-2.0	2.0 Piston Assembly – Needle Spray†
7.	4328466	SH-1002-A	Piston Assembly – Needle Spray†
	0328004	SH-2	Coupling Ring† – DISCONTINUED
—	0328005	SH-2-N	Coupling Ring – Needle Spray† SH-1002-A – available in SH-1008-A for 2.0 & 2.5 gpm
	4328469	SH-1008-A	Repair Kit for Needle Spray Showerhead includes Items Nos. 2-5 at left (2.5 gpm).

† Includes SH-3 gasket.‡ Chrome plated. Consult factory for other available finishes. * SH-45 Spacer supplied only with 2.0 High Efficiency Showerhead models.

FLOW CONTROL MODEL CONVERSION

To convert an older Act-O-Matic showerhead to a flow control model, use repair kit **SH-1008-A**. Repair Kit contains gasket (item 2), piston assembly – needle spray (item 4) and coupling ring – needle spray (item 5).

NEEDLE SPRAY

NOTE: To properly repair an Act-O-Matic showerhead, it is important to identify needle spray part designs. Shower heads with 3 gpm (11 Lpm) or 2.5 gpm (9.4 Lpm) flow controls produced since 1985 use needle spray piston assembly and a needle spray coupling ring. Needle spray shower heads can be identified by the following: coupling ring (SH-2-N) has groove on knurled diameter; plus an "N" marked on the back of the black spray disc in the piston assembly. When repairing an Act-O-Matic shower head with a flow control it is important to identify whether the part is of the needle spray design.

SLOAN ACT-O-MATIC® MODELS

In accordance with Federal and State water conservation requirements, all Sloan Act-O-Matic showerheads manufactured after January 1, 1994 are available only with an integral 2.5 gpm (9.4 Lpm) flow control. Replacement components will continue to be available for non-flow control Act-O-Matic showerhead models. Act-O-Matic showerheads rated at 3 gpm (11 Lpm) should be repaired using the components shown for the current 2.5 gpm (9.4 Lpm) models.

For Sloan Act-O-Matic model 100 series shower-heads (discontinued in 1970) use piston assembly SH-1003-A and SH-2-N.

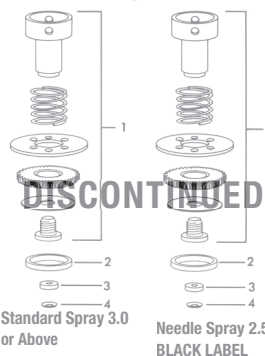

SHOWERHEAD REPAIR KITS

Code No.	Part No.	Description
For Standard Spray		
4328470	N/A	Repair Kit for Standard Spray Showerhead includes Items Nos. 1-4 (below)
For Needle Spray		
4328466	SH-1002-A	Repair Kit for Needle Spray Showerhead includes Items Nos. 1-4 (below)
Additional Repair Items		
0328326PK	SH-72	CP Ball Joint
0328068	SH-2N	Coupling Ring Needle Spray (2.5 gpm)
—	SH-1015-A	1.8 Repair Kit (Flow Control Only)
4328001	SH-1014-A	2.0 Repair Kit (Flow Control Only)
4328469	SH-1008-A	2.5 Conversion Kit
4328287	SH-1004-A	2.5 Repair Kit - 2.5 Flow Control & SH-3
0328097	AC1A - 2.5	Shower Body Assembly (2 & 7 on Chart)
0328206	AC1A - 2.0	Shower Body Assembly (2 & 7 on Chart)

Act-O-Matic® Showerhead

SH-1009-A-2.5 REPAIR KIT FOR AC-450 MODEL SHOWERHEAD INCLUDES:

Item	Description
1.	Showerhead Spray Disc Assembly
2.	Spray Disc O-ring-SH-513
3.	Adjustment Screw O-ring-SH-75
4.	Pipe Fitting O-ring-SH-512
5.	2.5 gpm (9.4 Lpm) Flow Control Kit Code No. 0328375 , Part SH-313-A
	1.8 gpm (6.8 Lpm) Flow Control Kit Code No. 0325377

Note: Items 2, 3 and 4 are also available in O-ring replacement kit SH-1001-A.

SERVICING INSTRUCTIONS

1. Remove showerhead from wall by unscrewing two 5/32" allen head wrench.
2. Remove adjustment screw from showerhead body.
3. Remove spray disc assembly by pushing through showerhead body.
4. Clean inside of showerhead body of all sediment and replace all O-ring seals.
5. Replace (or add) flow control in pipe fitting.
6. Replace spray disc assembly and reassemble showerhead in reverse order.

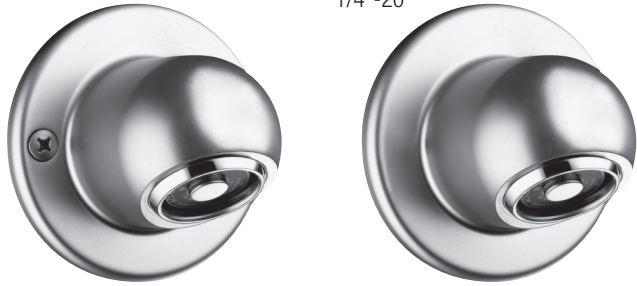
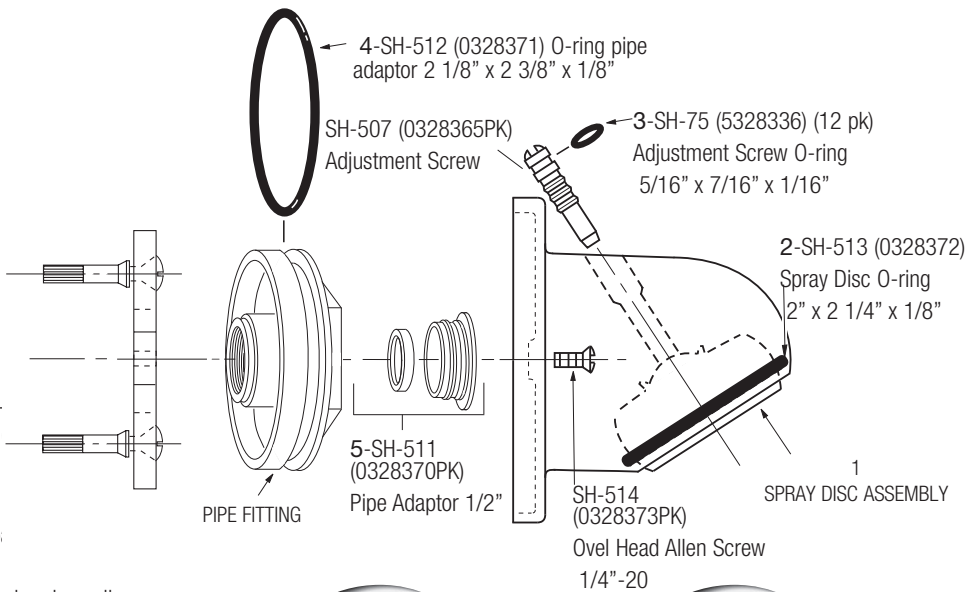

AC-450 **4024500**

AC-460 **4024600**

AC-450 **4024531 (1.8 gpm)**

AC-460 **4024631 (1.8 gpm)**

Institutional style self-cleaning showerhead similar Sloan Act-O-Matic institutional style models.

In accordance with Federal and State water conservation requirements, all Sloan Act-O-Matic® showerheads manufactured after January 1, 1994 are available only with an integral 2.5 gpm (9.4 Lpm) flow control. All model variations of AC-450/AC-460 Act-O-Matic showerheads can be repaired using the SH-1009-A repair kit (see above). When repairing an older AC-450 without a flow control, install the 2.5 gpm (9.4 Lpm) flow control supplied with the repair kit.

SHOWERHEAD FLOW CONTROLS

Code No.	Part No.	Description
For Standard Showerheads		
4328285	AC-300-A	B-4 4 Gallon Flow Control for Showerhead Models AC-10, AC-11, AC-51 And AC-75 – OBSOLETE
4328287	AC-310-A	B-3 3 Gallon Flow Control for Showerhead Models AC-10, AC-11, AC-51 And AC-75 – OBSOLETE
For Institutional Showerheads		
4328290	AC-320-A	B-4 4 Gallon Flow Control for Showerhead Models AC-450 – OBSOLETE
4328289	AC-325-A	B-3 3 Gallon Flow Control for Showerhead Models AC-450 – OBSOLETE
Additional Repair Items		
4328002	SH-1019-A	Disc & Flow Control (converts to 2.0)
4328003	SH-1020-A	2.0 Flow Control Kit
4328210	SH-1010-A	2.5 Flow Control Repair Kit
4328471	SH-1009-A	2.5 Repair Kit
4328005	SH-1016-A	1.8 Flow Control Repair Kit
4328006	SH-1017-A	1.8 Showerhead Repair Kit
0328373PK	SH-514	CP Oval Head Allen Screw 1/4" -20
0328372	SH-513	O-ring 2x2-1/4" x 1/8" Pipe Adaptor o-ring
0328371	SH-512	O-ring 2-1/8" x 2 3/8" x 1/8" Spray Disc o-ring
0328385PK	SH-502N	CP Spherical Ring Needle Spray
0328080PK	SH-37	CP Phillips Wood Screw #14 x 1 1/2"

TO CLEAN SPRAY DISC ASSEMBLY:

1. Disassemble showerhead according to servicing instructions shown above.
2. Use spanner wrench or pliers to disassemble spray disc assembly (see exploded view).
3. Clean sediment and debris from all components.
4. Replace with repair kit Code No. **4328471**, part SH-1009-A if necessary. For 2.5 Gpm use code No. 4328006 For 1.8 Gpm use SH-1017-A

SPRAY DISC ASSEMBLY Item 1 (see above illustration)

This page intentionally left blank.

This page intentionally left blank.

Sloan Sales Representatives

Alabama

Will & Pierce Agency
6612 Pine Hill Rd
Daphne, AL 36526
251/621-1550
jsullivan@willandpierce.com

Alaska

Braley-Gray
2818 E 2nd St
Vancouver, WA 98661-7778
503-249-6972
sales@braleygray.com
W:braleygray.com

Arizona

Southwestern Mechanical
Sales Co.
1440 W San Pedro St
Gilbert, AZ 85233
PH 1-480-813-1313
swpsg.com

Arkansas

C. A. Riner Co., Inc.
7620 Hardin Dr
N. Little Rock, AR 72117
501/834-1400
cariner.com

California – South

Delco Sales
5375 E. Hunter Ave
Anaheim, CA 92807-2054
714/888-2444
sales@delcosales.com

California – North

Kliman Sales Inc.
1245 N. 5th St
San Jose, CA 95112
408/275-1784
info@klimansales.com
klimansales.com

Kliman Sales Inc.
8560 23rd Ave
Sacramento, CA 95826
916/379-0784
klimansales.com

Colorado

Marshall-Rodeno Associated
5700 E. 39th Ave
Denver, CO 80207
303/575-6701
sales@marshallrodeno.com
marshallrodeno.com

Connecticut

Yost Associates
224 Eastern Blvd
Glastonbury, CT 06033
860/659-0301
yostassociates.com

Delaware

Burns Cope Associates
4009-K Market St. Ste K
Aston, PA 19014-3140
610/497-1722
burnscope.com

District of Columbia

The Joyce Agency
3933 Avion Park Ct
Suite B102B
Chantilly, VA 20151
800/291-9298 or
703/866-3111
thejoyceagency.com

Florida

Spirit Group
3563 Lake Breeze Drive
Orlando, FL 32808
407-291-6035
info@spiritgroup.com

Florida-Panhandle

Will & Pierce Agency
6612 Pine Hill Rd
Daphne, AL 36526
251/621-1550
jsullivan@willandpierce.com

Georgia

Southern Spec
2125 Corporate Dr Ste 105A
Marietta, GA 30067
770/627-5458
southernpec.com

Hawaii

Delco Sales
94-1388 Moaniani Street #114
Waipahu, HI 96797
PH 808-842-7900
Hawaii@delcosales.com

Idaho – Southwest

Braley-Gray & Associates
900 E. Overland Rd
Meridian, ID 83642
208/898-9410
braleygray@msn.com

Idaho – North

R. E. Fitzpatrick Sales, Inc.
4109 West Nike Dr
West Jordan, UT 84088
801/282-0700
fitzpatricksales.com

Idaho – Southeast

R. E. Fitzpatrick Sales, Inc.
4109 West Nike Dr
West Jordan, UT 84088
801/282-0700
fitzpatricksales.com

Illinois – North

REPCO Associates, Inc.
1775 W. Armitage Ct
Addison, IL 60101
630/932-9900
brian@repcocoassociates.com

Illinois – Central

REPCO Associates, Inc.
1775 W. Armitage Ct
Addison, IL 60101
309/762-3700
harry.carlson@comcast.com

Illinois – South

MR & Associates
2726 South Brentwood Blvd,
Brentwood, MO 63144
PH 314-962-8960
E:quotes@mrassocinc.com

Indiana

P-M Associates, Inc.
9901 E. 30th Street
Indianapolis, IN 46229
317/827-0419
orders@p-massoc.com

Iowa

Service Reps, Inc.
15030 "A" Cir
Omaha, NE 68144
402/333-2095
orders@servicerepsinc.com

Kansas

Hebco Inc.
4304 S. Washington
Independence, MO 64055
913/491-0797
quotes@hebcocoreps.com

Kentucky – East

BBN Sales, Inc.
3737 Spring Grove Ave
Cincinnati, OH 45223
513/681-9999
bbsales@cinci.rr.com

Kentucky – Western

P-M Associates, Inc.
9901 E. 30th Street
Indianapolis, IN 46229
317/827-0419
orders@p-massoc.com

Louisiana

BBWC Sales
2728 Crestview Ave
Kenner, LA 70062
PH 504-602-8100
W:bbwcsales.com

Maine

J. H. Pokorny Associates, LLC
1502 Providence Hwy, Ste 4
Norwood, MA 02062
781/762-2661
jhpokorny.net

Maryland

The Joyce Agency
3933 Avion Park Ct
Ste B102B
Chantilly, VA 20151
800/291-9298 or
703/866-3111
thejoyceagency.com

Massachusetts – East

J.H. Pokorny Associates, LLC
1502 Providence Hwy, Ste 4
Norwood, MA 02062
781/762-2661
jhpokorny.net

Massachusetts – West

Yost Associates
224 Eastern Blvd
Glastonbury, CT 06033
860/659-0301
yostassociates.com

Michigan – East

Diversified Spec. Sales, Inc.
13261 Northend Ave
Oak Park, MI 48237
248/398-2400
diversifiedspec.com

Michigan – West

Diversified Spec. Sales, Inc.
317 32nd St. SW
Grand Rapids, MI 49548
616/785-9000
diversifiedspec.com

Michigan – Upper Peninsula

Badgerland Trading
of Wisconsin
2415 S. 170th St
New Berlin, WI 53151
262/827-3177
dan@badgerlandtrading.com

Minnesota

Bongard Corporation
13366 Lake Drive
Forest Lake, MN 55025
651/982-9802
bongard@bongard.com

Mississippi

Will & Pierce Agency
6612 Pine Hill Rd
Daphne, AL 36526
251/621-1550
jsullivan@willandpierce.com

Missouri – East

MR & Associates Inc.
2726 S. Brentwood Blvd
St. Louis, MO 63144
PH 314-962-8960
W:mrassocinc.com
E:quotes@mrassocinc.com

Missouri – West

Hebco Inc.
4304 S. Washington
Independence, MO 64055
913/491-5126
quotes@hebcocoreps.com

Montana

Vemco
2016 2nd Ave. North
Billings, MT 59101
406/248-8373
mail@vemcoinc.com

Nebraska – East

Service Reps, Inc.
15030 "A" Cir
Omaha, NE 68144
402/333-2095
orders@servicerepsinc.com

Nevada – Northeast

R.E. Fitzpatrick Sales, Inc.
4109 W. Nike Dr
West Jordan, UT 84088
801/282-0700
fitzpatricksales.com

Nevada – Reno & Northwest

Kliman Sales Inc.
8560 23rd Ave
Sacramento, CA 95826
PH: 916-379-0784
W:klimansales.com

Nevada – Las Vegas & South

Southwestern Mechanical
Sales Co.
3191 Builders Ave
Las Vegas, NV 89101
702/368-2561
E:jeff@svmech.com

New Hampshire

J.H. Pokorny Associates, LLC
1502 Providence Hwy, Ste 4
Norwood, MA 02062
781/762-2661
jhpokorny.net

New Jersey – North

Maloney & Curcio Inc
1090 Bristol Rd
Mountainside, N.J. 07092
PH 908-486-0900
F 908-486-1222
W:maloney-curcio.com

New Jersey – South

Burns Cope Associates
4009-K Market St Ste K
Aston, PA 19014
610/485-2828
burnscope.com

New Mexico

Southwestern Mechanical
Sales Co.
1440 W San Pedro St
Gilbert, AZ 85233
PH 1-866-707-7020
W: swpsg.com

New York – Lower

Edwards, Platt & Deely Inc.
368 Wyandanch Ave
North Babylon, NY 11703
631/253-0600
epdreps.com

New York – Upper

WMS Sales, Inc.
9580 County Rd
Clarence Center, NY 14032
716/741-9575
wmssales.com

North Carolina

Smith & Stevenson
4935 Chastain Avenue
Charlotte, NC 28217
PH 704-525-3388
W:smithandstevenson.com

North Dakota

Bongard Corporation
13366 Lake Drive
Forest Lake, MN 55025
651/982-9802
bongard@bongard.com

Ohio – Northeast

2057 East Aurora Rd Ste D
Twinsburg, OH
513/681-9999
bbsales@cinci.rr.com

Ohio – Central & South

BBN Sales, Inc.
3737 Spring Grove Ave
Cincinnati, OH 45223
513/681-9999
bbsales@cinci.rr.com

Ohio – Northwest

Diversified Spec. Sales, Inc.
13261 Northend Ave
Oak Park, MI 48237
248/398-2400
diversifiedspec.com

Oklahoma

Pannell Associates Sales Co.
5411 S. 101st East Ave
Tulsa, OK 74146
918/664-7732
clp@pannellassociates.com
pannellassociates.com

Oregon

Braley Gray & Associates
2818 E. 2nd St
Vancouver, WA 98661
PH: 360-693-9900
E:sales@braleygray.com
W:braleygray.com

Pennsylvania – West

J. B. O'Connor Co., Inc.
202 Commerce Blvd
Lawrence, PA 15055
724/745-5300
office@jboconnor.com
https://www.jboconnor.com

Pennsylvania – Far North

WMS Sales, Inc.
9580 County Rd
Clarence Center, NY 14032
716/741-9575
wmssales.com

Pennsylvania – East

Burns Cope Associates
4009-K Market St Ste K
Aston, PA 19014
610/485-2828
burnscope.com

Rhode Island

Yost Associates
224 Eastern Blvd
Glastonbury, CT 06033
860/659-0301
yostassociates.com

South Carolina

Smith & Stevenson
4935 Chastain Avenue
Charlotte, NC 28217
PH 704-525-3388
W:smithandstevenson.com

South Dakota

Bongard Corporation
13366 Lake Drive
Forest Lake, MN 55025
651/982-9802
bongard@bongard.com

Tennessee

Hydro Spec Inc.
304-C Hill Ave
Nashville, TN 37210
615/291-6331
info@hydrospecinc.com

Texas – North

Dillard Associates
1504 Selene Dr
Carrollton, TX 75006
972/278-2000
sales@dillardassoc.com
dillardassoc.com

Texas – South

Dillard Associates
6100 Tri County Pkwy
Schertz, TX 78154
210/824-4881
dillardassoc.com

Texas – El Paso

Southwestern Mechanical
Sales Co.
1440 W San Pedro St
Gilbert, AZ 85233
PH 1-866-707-7020
W: swpsg.com

Utah

R.E. Fitzpatrick Sales, Inc.
4109 West Nike Dr
West Jordan, UT 84088
801/282-0700
fitzpatricksales.com

Vermont

J.H. Pokorny Associates, LLC
1502 Providence Hwy, Ste 4
Norwood, MA 02062
781/762-2661
jhpokorny.net

Virginia – North & West

The Joyce Agency
3933 Avion Park Ct
Suite B102B
Chantilly, VA 20151
800/291-9298 or
703/866-3111
thejoyceagency.com

Virginia – Central & South

The Joyce Agency
700 Thimble Shoals Blvd
Suite 106
Newport News, VA 23606
703/866-3111
thejoyceagency.com

Washington

Braley-Gray & Associates
2427 6th Ave. South
Seattle, WA, 98134
PH: 206-405-4370
sales@braleygray.com
W: braleygray.com

West Virginia – Far Northeast

The Joyce Agency
3933 Avion Park Ct
Suite B102B
Chantilly, VA 20151
800/291-9298 or
703/866-3111
thejoyceagency.com

West Virginia – Central & Far South

J. B. O'Connor Co., Inc.
P. O. Box 12927
Pittsburgh, PA 15241
724/745-5300
jboconnor.com

Wisconsin South & East

Badgerland Trading
of Wisconsin
2415 S. 170th St
New Berlin, WI 53151
262/827-3177
badgerlandtrading.com

Wisconsin Northwest

Bongard Corporation
13366 Lake Drive
Forest Lake, MN 55025
651/982-9802
bongard@bongard.com

Wyoming – Southwest

R.E. Fitzpatrick Sales, Inc.
4109 West Nike Dr
West Jordan, UT 84088
801/282-0700
fitzpatricksales.com

Wyoming – North

Vemco
2016 2nd Ave North
Billings, MT 59101
PH 406-248-8373
W: Vemcoinc.com

Canada

Dobbin Sales Ltd
51 Terecar Dr, Unit 2
Vaughan, ON L4L 0B5
800/565-8515 or
703/866-3111
thejoyceagency.com

Mexico

Sloan de Mexico
S. de R.L. de C.V.
Carretera a los Pinos Km.-1
Ramos Arizpe, Coahuila
Mexico, CP 25900
PH (52) 844/488-0669,
PH (52) 844/488-0299
E:servicio.clientes@sloan.com.mx

Puerto Rico

J. A. Short, Inc.
6-21 Calle Oviedo
Torrimar, Guaynabo, PR 00966
787/536-3273
jashort@jas-sales.com

Headquarters

10500 Seymour Avenue
Franklin Park, IL 60131-1238
P: +1 847.671.4300 / 800.982.5839
F: +1 847.671.4380 / 800.447.8329
customer.service@sloan.com
sloan.com